

## Remote I/O R3 Series

### RTD INPUT MODULE

(high accuracy, 4 points, isolated, tension clamp terminal block)

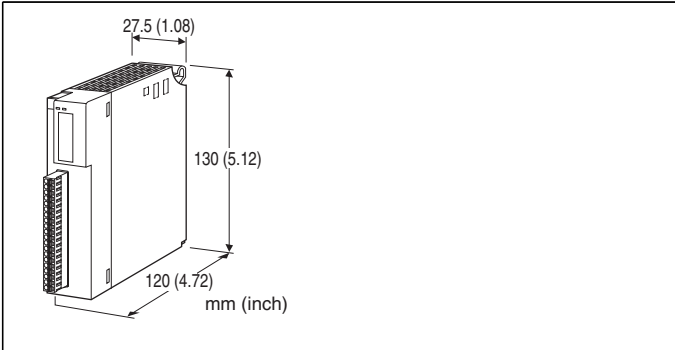

### MODEL: R3S-RS4A[1][2]

#### ORDERING INFORMATION

- Code number: R3S-RS4A[1][2]
- Specify a code from below for each of [1] and [2].  
(e.g. R3S-RS4AW/Q)
- Specify the specification for option code /Q  
(e.g. /C01/SET)

#### NO. OF CHANNELS

4A: 4 channels, high accuracy

#### [1] COMMUNICATION MODE

S: Single  
W: Dual

#### [2] OPTIONS

blank: none  
/Q: Options other than the above (specify the specification)

#### SPECIFICATIONS OF OPTION: Q (multiple selections)

##### COATING (For the detail, refer to M-System's web site.)

- /C01: Silicone coating
- /C02: Polyurethane coating
- /C03: Rubber coating

##### EX-FACTORY SETTING

/SET: Preset according to the Ordering Information Sheet  
(No. ESU-8345)

#### GENERAL SPECIFICATIONS

##### Connection

Internal bus: Via the Installation Base (model: R3-BSx)

**Input:** Separable tension clamp terminal (applicable wire size: 0.2 to 1.5 mm<sup>2</sup>, stripped length 10 mm)

**Internal power:** Via the Installation Base (model: R3-BSx)

**Isolation:** Input 1 to input 2 to input 3 to input 4 to internal bus or internal power

**Sensor type:** Selectable with the side DIP SW

**Temperature unit:** °C or °F selectable with the side DIP SW

**Conversion rate:** Selectable with the side DIP SW

**Burnout detection:** Upscale or downscale selectable with the side DIP SW

**Linearization:** Standard

**RUN indicator:** Bi-color (red/green) LED;

Red when the bus A operates normally;

Green when the bus B operates normally;

Amber when both buses operate normally.

**ERR indicator:** Bi-color (red/green) LED;

Red with burnout; Green in normal operating conditions.

#### INPUT SPECIFICATIONS

Maximum leadwire resistance: 10 Ω per wire

Sensing current: ≤ 0.5 mA

##### Temperature range

RTD	°C	
	CONFORMANCE RANGE (°C)	BURNOUT VALUE (°C × 100)
Pt 100 (JIS '97, IEC)	-50 to +200	-24000, +32767
Pt 100 (JIS '89)	-50 to +200	-24000, +32767
JPt 100 (JIS '89)	-50 to +200	-23600, +32767
Pt 1000	-50 to +200	-24000, +32767

RTD	°F	
	CONFORMANCE RANGE (°F)	BURNOUT VALUE (°F × 10)
Pt 100 (JIS '97, IEC)	-58 to +392	-4000, +6218
Pt 100 (JIS '89)	-58 to +392	-4000, +6218
JPt 100 (JIS '89)	-58 to +392	-3928, +6218
Pt 1000	-58 to +392	-4000, +6218

#### INSTALLATION

**Operating temperature:** -10 to +55°C (14 to 131°F)

**Operating humidity:** 30 to 90 %RH (non-condensing)

**Atmosphere:** No corrosive gas or heavy dust

**Mounting:** Installation Base (model: R3-BSx)

**Weight:** 200 g (0.44 lb)

#### PERFORMANCE

**Conversion accuracy:** ±0.2°C or ±0.4°F

**Conversion rate:** 250 msec. or 1 sec. selectable

**Data range**

°C: Engineering unit value × 100 (integer)

°F: Engineering unit value × 10 (integer)

**Data allocation:** 4

**Current consumption:** 70 mA

Temp. coefficient:  $\pm 0.015\text{ \%}/^{\circ}\text{C}$  ( $\pm 0.008\text{ \%}/^{\circ}\text{F}$ )  
 Resolution:  $0.03^{\circ}\text{C}$  ( $0.1^{\circ}\text{F}$ )  
 Burnout response time:  $\leq 2\text{ sec.}$   
 Insulation resistance:  $\geq 100\text{ M}\Omega$  with 500 V DC  
 Dielectric strength: 1500 V AC @ 1 minute (input 1 to input 2 to input 3 to input 4 to internal bus or internal power)  
 2000 V AC @ 1 minute (power input to FG; isolated on the power supply module)

## EXTERNAL VIEW

### FRONT VIEW

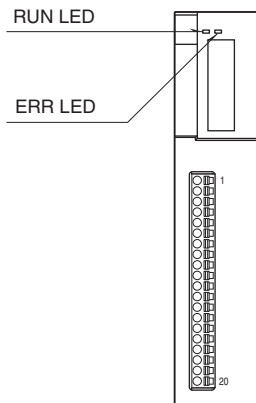

### SIDE VIEW

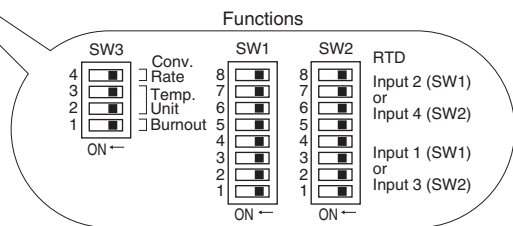
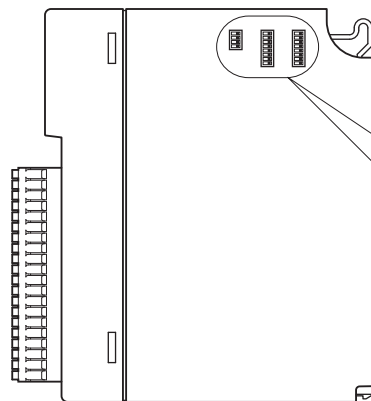

## INPUT DATA DESCRIPTIONS

### ANALOG DATA (TEMPERATURE DATA)

16-bit binary data.  
 With  $^{\circ}\text{C}$  temperature unit, raw data is multiplied by 100. For example,  $25.5^{\circ}\text{C}$  is converted into 2550.  
 With  $^{\circ}\text{F}$  temperature unit, raw data is multiplied by 10. For example,  $135.4^{\circ}\text{F}$  is converted into 1354.  
 Minus temperature is converted into negative values, represented in 2's complements.



## EXTERNAL DIMENSIONS unit: mm (inch)

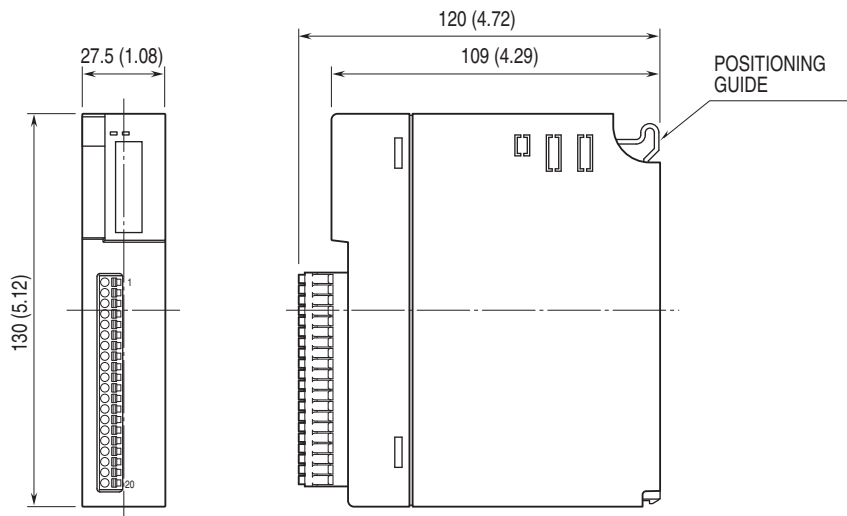

## SCHEMATIC CIRCUITRY & CONNECTION DIAGRAM

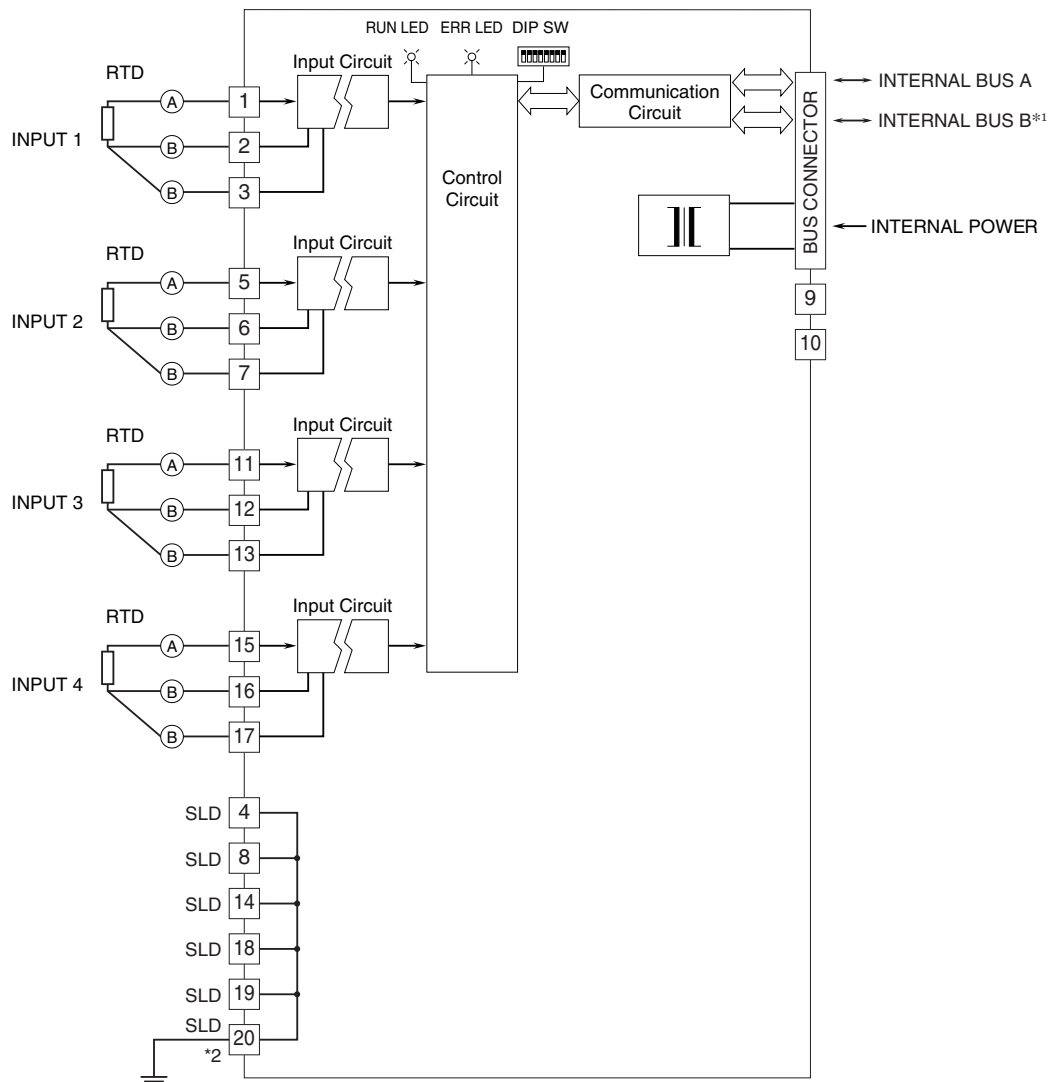

\*1. For dual redundant communication.

\*2. To make use of shield line, connect to SLD and ground the terminal 20's shield.

Note: Do not use void terminals.

### • Unused Input Channels

Close across the unused input terminals with a resistor as shown below and set the DIP switch for Pt 100 input.

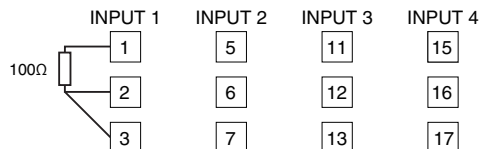

Unused channels left open are equal to the burnout, which turns the red ERR LED on and sets a burnout flag at the PLC or the host device.

Unused channels can be specified and set so on the PC Configurator Software (model: R3CON) without needing to connect resistors at the field terminals.

**INPUT TERMINAL ASSIGNMENT**

PIN No.	FUNCTION
1	INA1
2	INB1
3	INb1
4	SLD
5	INA2
6	INB2
7	INb2
8	SLD
9	NC
10	NC
11	INA3
12	INB3
13	INb3
14	SLD
15	INA4
16	INB4
17	INb4
18	SLD
19	SLD
20	SLD



Specifications are subject to change without notice.