

Model:TA2020FL-100

Characteristics:

Vacuum epoxy resin encapsulated, silicon steel sheet core, high overload ability.

Technical index:

Mounting type: Plate type

Material of the core: Silicon steel sheet

Flame resistance: UL94-V0

Execution standard: GB1208-2006

Operating temperature: $-35^{\circ}\text{C} \sim +85^{\circ}\text{C}$

Storage temperature: $-45^{\circ}\text{C} \sim +95^{\circ}\text{C}$

Frequency range: 20Hz-20KHz

Dielectric strength: $\geq 3.5\text{KV}$ 50Hz 1min

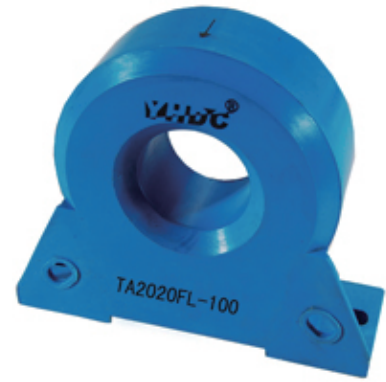

Electrical parameters:

Rated input	0-300	A
Max.input	506	A
Rated output	0-0.3	A
Turns ratio	1: 1000	
Accuracy	± 1	%
Linearity	≤ 0.2	%
Phase difference	$\leq 54.3'$	
max: Max. sampling resistance	20	Ω
Weight		g

Schematic diagram:

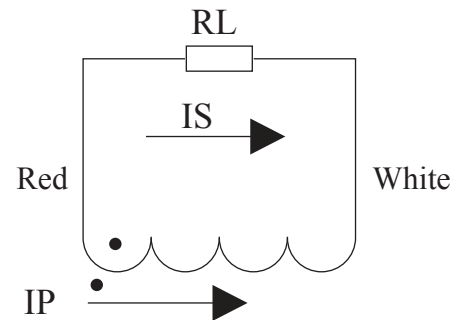

Dimensions (in mm) :

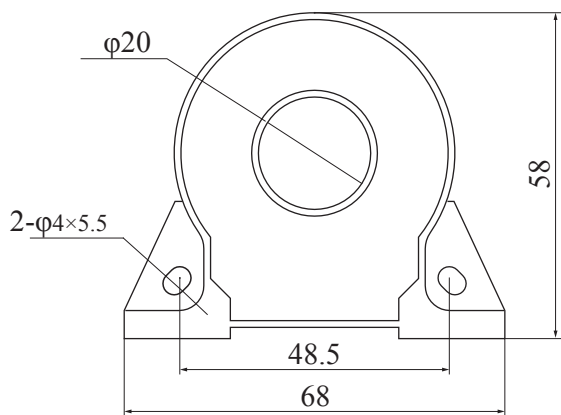

Front view

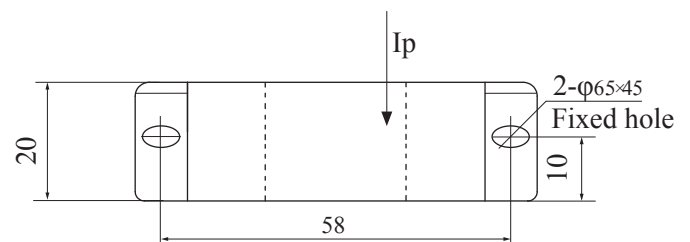

Bottom view