

SS-22F20-GXXX

直柄
G-Switch P/N
Switch Height (mm)

- G020=2.0 G030=3.0
- G040=4.0 G050=5.0
- G055=5.5 G060=6.0
- G065=6.5 G070=7.0
- G075=7.5 G080=8.0
- G085=8.5 G090=9.0
- G095=9.5 G100=10.0

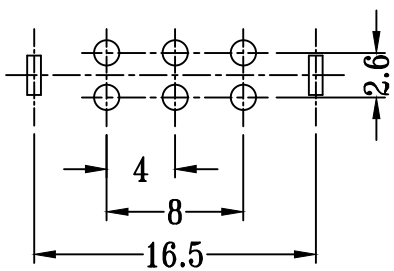
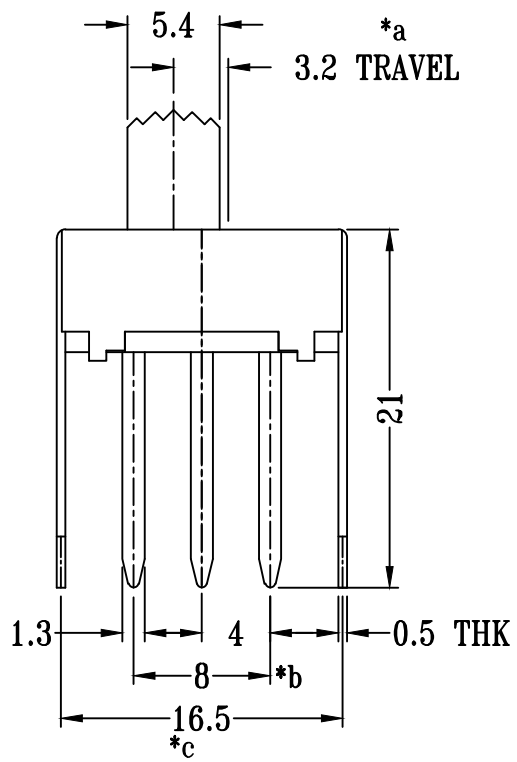

**P.C.B LAYOUT
BOTTOM VIEW**

G-Switch Specification:
 Electrical Specifications: 1.0A/DC24V
 Contact resistance (CR): ≤50mΩ
 Insulation Resistance(IR): ≥100MΩ DC250V
 Compressive strength (WV): AC250V 1minute
 Operating temperature: -25°C~+70°C
 Storage humidity: <85%RH
 Electrical life: 10,000Cycles.

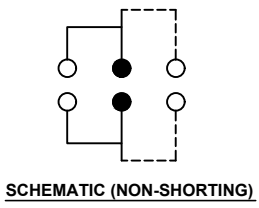

	G-Switch Electronic (HongKong) CO.,Ltd.		
	DESIGN FengFengChen	DATE 2019.05.29	Molde code:
Unless otherwise specified, Tolerance:	CHECKED	DATE	SS-22F20-GXXX
X. ±0.30	APPROVED	DATE	
X.x ±0.20	http://www.dg-switch.com		REV.: X1 SCALE: 4:1 UNIT: mm
X.xx ±0.15	TEL:0769-82388879		SIZE: A4 SHEET: 1/1
X.xxx ±0.10			
Angles ±3°			