



U74LVC244

CMOS IC

OCTAL BUFFER/DRIVER WITH 3-STATE OUTPUTS

DESCRIPTION

The UTC **U74LVC244** contains two 4-bit line drivers with separate output-enable (\overline{OE}) inputs. When \overline{OE} is low, the device passes data from the A to the Y. When \overline{OE} is high, the outputs are in the high-impedance state.

The UTC **U74LVC244** can be used in a mixed 3.3V/5V system environment.

FEATURES

- * Operate From 1.65V to 3.6V
- * Input Accept Voltages to 5.5V
- * Partial-Power-Down Mode Operation
- * Max tpd is 5.9ns at 3.3V

ORDERING INFORMATION

Ordering Number		Package	Packing
Lead Free	Halogen Free		
U74LVC244L-D20-T	U74LVC244G-D20-T	DIP-20	Tube
U74LVC244L-S20-T	U74LVC244G-S20-T	SOP-20	Tube
U74LVC244L-S20-R	U74LVC244G-S20-R	SOP-20	Tape Reel
U74LVC244L-P20-T	U74LVC244G-P20-T	TSSOP-20	Tube
U74LVC244L-P20-R	U74LVC244G-P20-R	TSSOP-20	Tape Reel

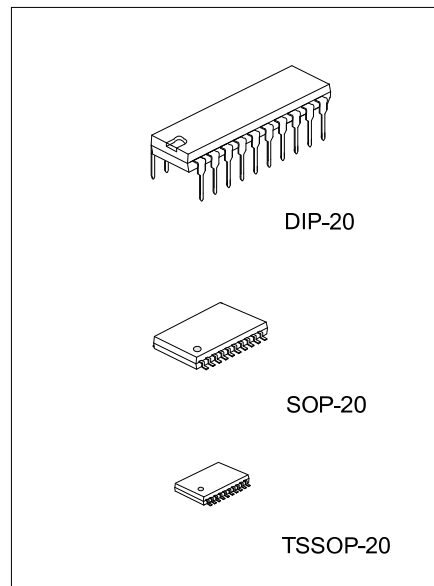

<p>U74LVC244L-S20-T</p> <p>(1) Packing Type (2) Package Type (3) Lead Free</p>	<p>(1) T: Tube, R: Tape Reel (2) D20: DIP-20, S20: SOP-20, P20: TSSOP-20 (3) L: Lead Free, G: Halogen Free</p>
--	--

MARKING INFORMATION

PACKAGE	MARKING
DIP-20/SOP-20/TSSOP-20	<p>→ Date Code L: Lead Free G: Halogen Free → Lot Code</p>

■ PIN CONFIGURATION

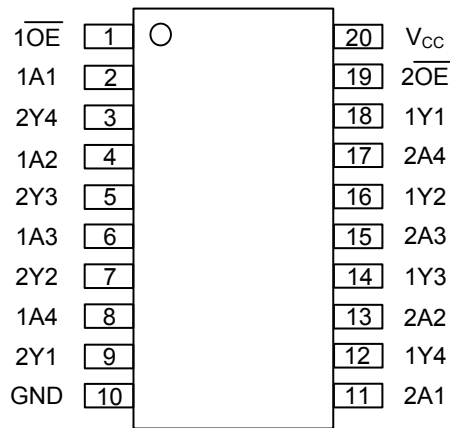

■ FUNCTION TABLE (each gate)

INPUT(\overline{OE})	INPUT(A)	OUTPUT(Y)
H	X	Z
L	H	H
L	L	L

■ LOGIC DIAGRAM (Positive Logic)

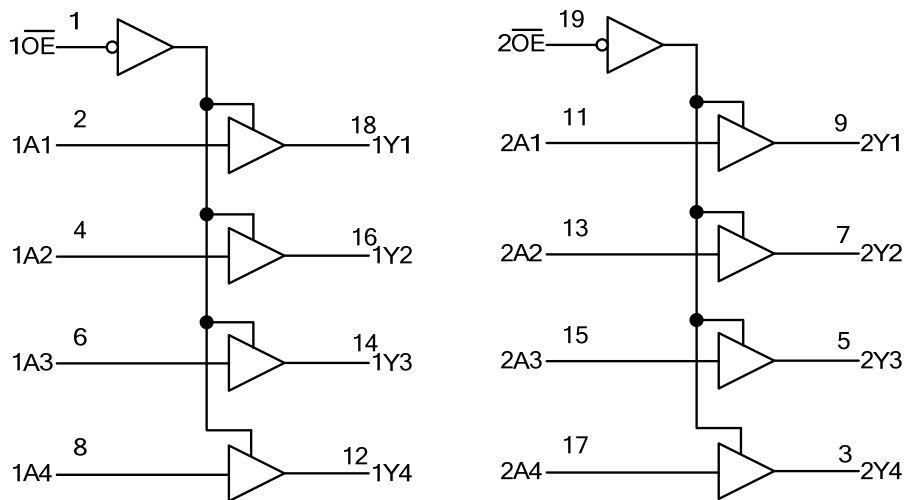

■ ABSOLUTE MAXIMUM RATINGS

PARAMETER	SYMBOL	RATINGS	UNIT
Supply Voltage	V_{CC}	-0.5~6.5	V
Input Voltage	V_{IN}	-0.5~ 6.5	V
Voltage applied to output in high-impedance or power-off state	V_{OUT}	-0.5~6.5	V
Voltage applied to output in high or low state		-0.5~ $V_{CC}+0.5$	
Input Clamp Current	I_{IK}	-50	mA
Output Clamp Current	I_{OK}	-50	mA
Output Current	I_{OUT}	±50	mA
V_{CC} or GND Current	I_{CC}	±100	mA
Operating Temperature	T_{OPR}	-40~ +125	°C
Storage Temperature	T_{STG}	-65 ~ +150	°C

Note: 1. The input and output voltage ratings may be exceeded if the input and output current ratings are observed.
 2. Absolute maximum ratings are those values beyond which the device could be permanently damaged.
 Absolute maximum ratings are stress ratings only and functional device operation is not implied.

■ RECOMMENDED OPERATING CONDITIONS

PARAMETER	SYMBOL	CONDITIONS	MIN	TYP	MAX	UNIT
Supply Voltage	V_{CC}	Operating	1.65		3.6	V
		Data retention only	1.5			V
Input Voltage	V_{IN}		0		5.5	V
Output Voltage	V_{OUT}		0		V_{CC}	V
High-Level Input Voltage	V_{IH}	$V_{CC}=1.65V$ to 1.95V	$0.65 \times V_{CC}$			V
		$V_{CC}=2.3V$ to 2.7V	1.7			V
		$V_{CC}=2.7V$ to 3.6V	2			V
Low-Level Input Voltage	V_{IL}	$V_{CC}=1.65V$ to 1.95V			$0.35 \times V_{CC}$	V
		$V_{CC}=2.3V$ to 2.7V			0.7	V
		$V_{CC}=2.7V$ to 3.6V			0.8	V
High-Level Output Current	I_{OH}	$V_{CC}=1.65V$			-4	mA
		$V_{CC}=2.3V$			-8	mA
		$V_{CC}=2.7V$			-12	mA
		$V_{CC}=3V$			-24	mA
Low-Level Output Current	I_{OL}	$V_{CC}=1.65V$			4	mA
		$V_{CC}=2.3V$			8	mA
		$V_{CC}=2.7V$			12	mA
		$V_{CC}=3V$			24	mA

■ THERMAL DATA

PARAMETER	SYMBOL	RATINGS	UNIT	
Junction to Ambient	θ_{JA}	DIP-20	69	°C /W
		SOP-20	58	
		TSSOP-20	83	

■ ELECTRICAL CHARACTERISTICS

PARAMETER	SYMBOL	TEST CONDITIONS	MIN	TYP	MAX	UNIT
High-Level Output Voltage	V_{OH}	$V_{CC}=1.65V$ to $3.6V$, $I_{OH}=-100\mu A$	$V_{CC}-0.2$			V
		$V_{CC}=1.65V$, $I_{OH}=-4mA$	1.29			
		$V_{CC}=2.3V$, $I_{OH}=-8mA$	1.9			
		$V_{CC}=2.7V$, $I_{OH}=-12mA$	2.2			
		$V_{CC}=3V$, $I_{OH}=-12mA$	2.4			
		$V_{CC}=3V$, $I_{OH}=-24mA$	2.3			
Low-Level Output Voltage	V_{OL}	$V_{CC}=1.65V$ to $3.6V$, $I_{OH}=100\mu A$			0.1	V
		$V_{CC}=1.65V$, $I_{OH}=4mA$			0.24	
		$V_{CC}=2.3V$, $I_{OH}=8mA$			0.3	
		$V_{CC}=2.7V$, $I_{OH}=12mA$			0.4	
		$V_{CC}=3V$, $I_{OH}=24mA$			0.55	
Input Leakage Current	$I_{I(LEAK)}$	$V_{CC}=3.6V$, $V_{IN}=5.5V$ or GND			± 1	μA
Power OFF Leakage Current	I_{OFF}	$V_{CC}=0V$, V_{IN} or $V_{OUT}=5.5V$			± 1	μA
Output OFF-State Current	I_{OZ}	$V_{CC}=3.6V$, $V_{OUT}=0$ or $5.5V$			± 1	μA
Quiescent Supply Current	I_q	$V_{CC}=3.6V$, $V_{IN}=V_{CC}$ or GND, $I_{OUT}=0$			1	μA
		$V_{CC}=3.6V$, $3.6V \leq V_{IN} \leq 5.5V$, $I_{OUT}=0$			1	
Additional Quiescent Supply Current	ΔI_q	$V_{CC}=2.7V$ to $3.6V$, One input at $V_{CC}-0.6V$, Other inputs at V_{CC} or GND			500	μA
Input Capacitance	C_I	$V_{CC}=3.3V$, $V_{IN}=V_{CC}$ or GND		4		pF
Output Capacitance	C_O	$V_{CC}=3.3V$, $V_{OUT}=V_{CC}$ or GND		5.5		pF

■ SWITCHING CHARACTERISTICS

PARAMETER	SYMBOL	TEST CONDITIONS	MIN	TYP	MAX	UNIT
From Input(A) to Output(Y)	t_{pd}	$V_{CC}=1.5V$	1	7	14.4	ns
		$V_{CC}=1.8V \pm 0.15V$	1	5.9	10.4	
		$V_{CC}=2.5V \pm 0.2V$	1	4.2	7.4	
		$V_{CC}=2.7V$	1	4.2	6.7	
		$V_{CC}=3.3V \pm 0.3V$	1.5	3.9	5.7	
From Input(\overline{OE}) to Output(Y)	t_{en}	$V_{CC}=1.5V$	1	8.3	17.8	ns
		$V_{CC}=1.8V \pm 0.15V$	1	6.4	12.1	
		$V_{CC}=2.5V \pm 0.2V$	1	4.6	9.1	
		$V_{CC}=2.7V$	1	5	8.4	
		$V_{CC}=3.3V \pm 0.3V$	1.5	4.5	7.4	
From Input(\overline{OE}) to Output(Y)	t_{dis}	$V_{CC}=1.5V$	1	7.2	15.6	ns
		$V_{CC}=1.8V \pm 0.15V$	1	5.8	11.6	
		$V_{CC}=2.5V \pm 0.2V$	1	3.7	7.3	
		$V_{CC}=2.7V$	1	3.8	6.6	
		$V_{CC}=3.3V \pm 0.3V$	1.5	3.8	6.3	

■ OPERATING CHARACTERISTICS

PARAMETER	SYMBOL	TEST CONDITIONS	MIN	TYP	MAX	UNIT
Power Dissipation Capacitance	C_{PD}	$\overline{OE}=0$, $f=10MHz$, $V_{CC}=1.8V$		43		pF
		$\overline{OE}=0$, $f=10MHz$, $V_{CC}=2.5V$		43		
		$\overline{OE}=0$, $f=10MHz$, $V_{CC}=3.3V$		44		
		$\overline{OE}=1$, $f=10MHz$, $V_{CC}=1.8V$		1		
		$\overline{OE}=1$, $f=10MHz$, $V_{CC}=2.5V$		1		
		$\overline{OE}=1$, $f=10MHz$, $V_{CC}=3.3V$		2		

■ TEST CIRCUIT AND WAVEFORMS

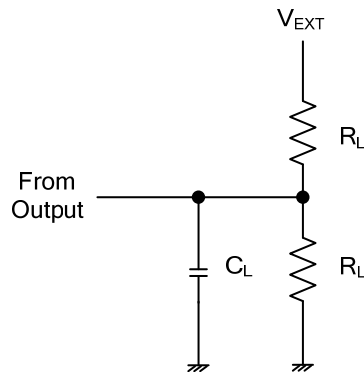

V _{CC}	V _{IN}	t _R /t _F	V _M	V Δ	C _L	R _L	V _{EXT}		
							t _{PLH} /t _{PHL}	t _{PZH} /t _{PHZ}	t _{PZL} /t _{PLZ}
1.5V	V _{CC}	≤2ns	V _{CC} /2	0.1V	15pF	2KΩ	OPEN	GND	2*V _{CC}
1.8V±0.15V	V _{CC}	≤2ns	V _{CC} /2	0.15V	30pF	1KΩ	OPEN	GND	2*V _{CC}
2.5V±0.2V	V _{CC}	≤2ns	V _{CC} /2	0.15V	30pF	500Ω	OPEN	GND	2*V _{CC}
2.7V	2.7V	≤2.5ns	1.5V	0.3V	50pF	500Ω	OPEN	GND	6V
3.3V±0.3V	2.7V	≤2.5ns	1.5V	0.3V	50pF	500Ω	OPEN	GND	6V

Fig-1 Load circuitry

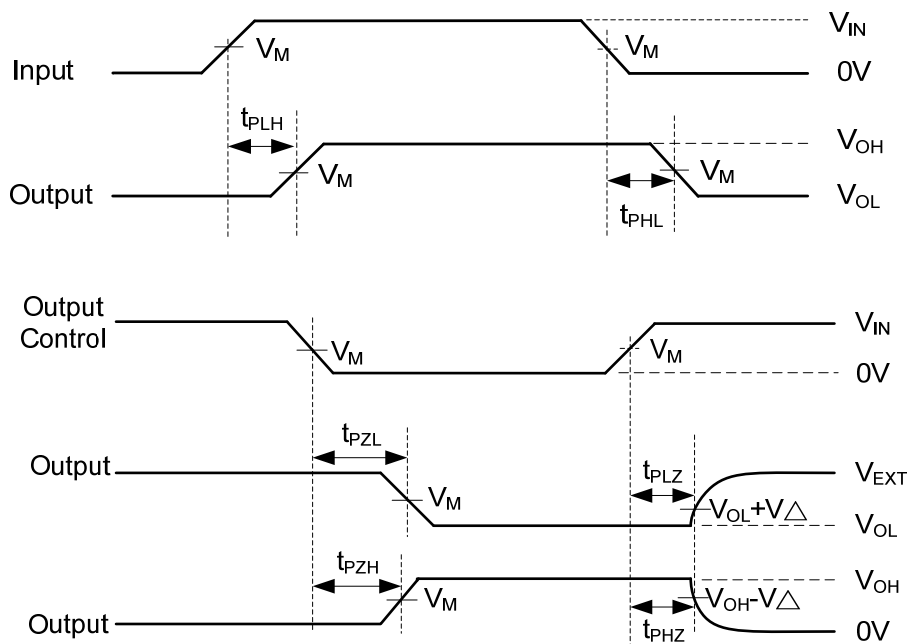

Fig-2 Propagation delay waves

UTC assumes no responsibility for equipment failures that result from using products at values that exceed, even momentarily, rated values (such as maximum ratings, operating condition ranges, or other parameters) listed in products specifications of any and all UTC products described or contained herein. UTC products are not designed for use in life support appliances, devices or systems where malfunction of these products can be reasonably expected to result in personal injury. Reproduction in whole or in part is prohibited without the prior written consent of the copyright owner. The information presented in this document does not form part of any quotation or contract, is believed to be accurate and reliable and may be changed without notice.