

## ADS7043 Ultra-Low Power, Ultra-Small Size, 12-Bit, 1-MSPS, SAR ADC

### 1 Features

- Industry's First SAR ADC with Nanowatt Power Consumption:
  - 243  $\mu\text{W}$  at 1 MSPS with 1.8-V AVDD
  - 780  $\mu\text{W}$  at 1 MSPS with 3-V AVDD
  - 78  $\mu\text{W}$  at 100 kSPS with 3-V AVDD
  - Less than 1  $\mu\text{W}$  at 1 kSPS with 3-V AVDD
- Industry's Smallest SAR ADC:
  - X2QFN-8 Package with 2.25-mm<sup>2</sup> Footprint
- 1-MSPS Throughput with Zero Data Latency
- Wide Operating Range:
  - AVDD: 1.8 V to 3.6 V
  - DVDD: 1.65 V to 3.6 V (Independent of AVDD)
  - Temperature Range:  $-40^{\circ}\text{C}$  to  $125^{\circ}\text{C}$
- Excellent Performance:
  - 12-Bit Resolution with NMC
  - $\pm 1$ -LSB (Max) DNL and INL
  - 70-dB SNR with 3-V AVDD
  - 80-dB THD with 3-V AVDD
- Unipolar, Pseudo-Differential Input Range:  $-\text{AVDD} / 2$  to  $\text{AVDD} / 2$
- Integrated Offset Calibration
- SPI™-Compatible Serial Interface: 16 MHz
- JESD8-7A Compliant Digital I/O

### 2 Applications

- Low-Power Data Acquisition
- Battery-Powered Handheld Equipment
- Level Sensors
- Ultrasonic Flow Meters
- Motor Controls
- Wearable Fitness
- Portable Medical Equipment
- Hard Drives
- Glucose Meters

### 3 Description

The ADS7043 is a 1-MSPS, analog-to-digital converter (ADC). The device supports a wide analog input voltage range ( $\pm 0.9$  V to  $\pm 1.8$  V) and includes a capacitor-based, successive-approximation register (SAR) ADC with an inherent sample-and-hold circuit. The SPI-compatible serial interface is controlled by the  $\overline{\text{CS}}$  and  $\text{SCLK}$  signals. The input signal is sampled with the  $\overline{\text{CS}}$  falling edge and  $\text{SCLK}$  is used for conversion and serial data output. The device supports a wide digital supply range (1.65 V to 3.6 V), enabling direct interface to a variety of host controllers. The device complies with the JESD8-7A standard for normal DVDD range (1.65 V to 1.95 V).

The device is available in 8-pin, miniature, leaded, and X2QFN packages and is specified for operation from  $-40^{\circ}\text{C}$  to  $125^{\circ}\text{C}$ . Miniature form-factor and extremely low-power consumption make this device suitable for space-constrained, battery-powered applications.

#### Device Information<sup>(1)</sup>

PART NAME	PACKAGE	BODY SIZE (NOM)
ADS7043	X2QFN (8)	1.50 mm x 1.50 mm
	VSSOP (8)	2.30 mm x 2.00 mm

(1) For all available packages, see the orderable addendum at the end of the datasheet.

#### Typical Application

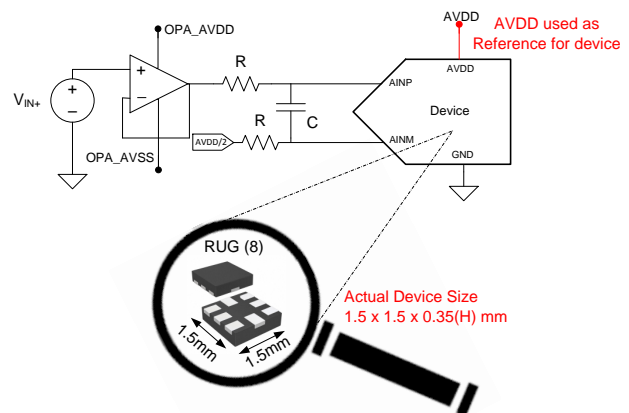

NOTE: The device is smaller than a 0805 (2012 metric) SMD component.



## Table of Contents

<b>1 Features</b> .....	<b>1</b>	8.3 Feature Description.....	<b>14</b>
<b>2 Applications</b> .....	<b>1</b>	8.4 Device Functional Modes.....	<b>18</b>
<b>3 Description</b> .....	<b>1</b>	<b>9 Application and Implementation</b> .....	<b>21</b>
<b>4 Revision History</b> .....	<b>2</b>	9.1 Application Information.....	<b>21</b>
<b>5 Pin Configuration and Functions</b> .....	<b>3</b>	9.2 Typical Applications .....	<b>21</b>
<b>6 Specifications</b> .....	<b>4</b>	<b>10 Power-Supply Recommendations</b> .....	<b>26</b>
6.1 Absolute Maximum Ratings .....	<b>4</b>	10.1 AVDD and DVDD Supply Recommendations.....	<b>26</b>
6.2 Handling Ratings.....	<b>4</b>	10.2 Estimating Digital Power Consumption.....	<b>26</b>
6.3 Recommended Operating Conditions.....	<b>4</b>	10.3 Optimizing Power Consumed by the Device .....	<b>26</b>
6.4 Thermal Information .....	<b>4</b>	<b>11 Layout</b> .....	<b>27</b>
6.5 Electrical Characteristics.....	<b>5</b>	11.1 Layout Guidelines .....	<b>27</b>
6.6 Timing Characteristics.....	<b>6</b>	11.2 Layout Example .....	<b>27</b>
6.7 Typical Characteristics .....	<b>7</b>	<b>12 Device and Documentation Support</b> .....	<b>28</b>
<b>7 Parameter Measurement Information</b> .....	<b>12</b>	12.1 Documentation Support .....	<b>28</b>
7.1 Digital Voltage Levels .....	<b>12</b>	12.2 Trademarks .....	<b>28</b>
<b>8 Detailed Description</b> .....	<b>13</b>	12.3 Electrostatic Discharge Caution.....	<b>28</b>
8.1 Overview .....	<b>13</b>	12.4 Glossary .....	<b>28</b>
8.2 Functional Block Diagram .....	<b>13</b>	<b>13 Mechanical, Packaging, and Orderable Information</b> .....	<b>28</b>

## 4 Revision History

### Changes from Original (November 2014) to Revision A

Page

• Made changes to product preview data sheet.....	<b>1</b>
---	----------

## 5 Pin Configuration and Functions

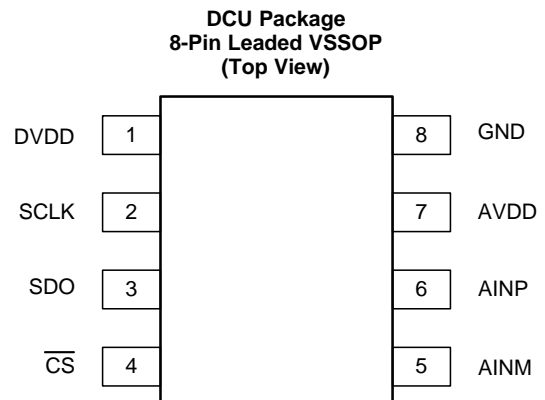
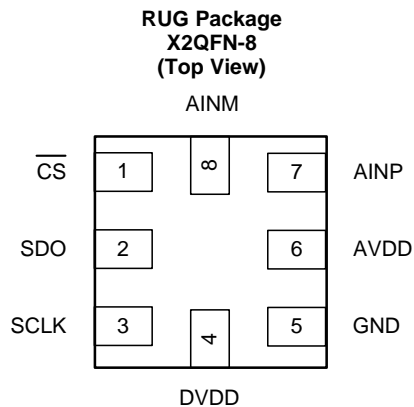

### Pin Functions

NAME	PIN		I/O	DESCRIPTION
	NO.			
	RUG	DCU		
AINM	8	5	Analog input	Analog signal input, negative
AINP	7	6	Analog input	Analog signal input, positive
AVDD	6	7	Supply	Analog power-supply input, also provides the reference voltage to the ADC
$\overline{\text{CS}}$	1	4	Digital input	Chip-select signal, active low
DVDD	4	1	Supply	Digital I/O supply voltage
GND	5	8	Supply	Ground for power supply, all analog and digital signals are referred to this pin
SCLK	3	2	Digital input	Serial clock
SDO	2	3	Digital output	Serial data out

## 6 Specifications

### 6.1 Absolute Maximum Ratings<sup>(1)</sup>

	MIN	MAX	UNIT
AVDD to GND	−0.3	3.9	V
DVDD to GND	−0.3	3.9	V
AINP to GND	−0.3	AVDD + 0.3	V
AINM to GND	−0.3	AVDD + 0.3	V
Digital input voltage to GND	−0.3	DVDD + 0.3	V

- (1) Stresses beyond those listed under *Absolute Maximum Ratings* may cause permanent damage to the device. These are stress ratings only, which do not imply functional operation of the device at these or any other conditions beyond those indicated under *Recommended Operating Conditions*. Exposure to absolute-maximum-rated conditions for extended periods may affect device reliability.

### 6.2 Handling Ratings

		MIN	MAX	UNIT	
T <sub>stg</sub>	Storage temperature range	−60	150	°C	
V <sub>(ESD)</sub>	Electrostatic discharge	Human body model (HBM), per ANSI/ESDA/JEDEC JS-001, all pins <sup>(1)</sup>	−2000	2000	V
		Charged device model (CDM), per JEDEC specification JESD22-C101, all pins <sup>(2)</sup>	−1000	1000	

- (1) JEDEC document JEP155 states that 500-V HBM allows safe manufacturing with a standard ESD control process.  
 (2) JEDEC document JEP157 states that 250-V CDM allows safe manufacturing with a standard ESD control process.

### 6.3 Recommended Operating Conditions

over operating free-air temperature range (unless otherwise noted)

		MIN	MAX	UNIT
AVDD	Analog supply voltage range	1.8	3.6	V
DVDD	Digital supply voltage range	1.65	3.6	V
T <sub>A</sub>	Operating free-air temperature	−40	125	°C

### 6.4 Thermal Information

THERMAL METRIC <sup>(1)</sup>		ADS7043		UNIT
		RUG (X2QFN)	DCU (VSSOP)	
		8 PINS	8 PINS	
R <sub>θJA</sub>	Junction-to-ambient thermal resistance	177.5	235.8	°C/W
R <sub>θJC(top)</sub>	Junction-to-case (top) thermal resistance	51.5	79.8	
R <sub>θJB</sub>	Junction-to-board thermal resistance	76.7	117.6	
ψ <sub>JT</sub>	Junction-to-top characterization parameter	1.0	8.9	
ψ <sub>JB</sub>	Junction-to-board characterization parameter	76.7	116.5	
R <sub>θJC(bot)</sub>	Junction-to-case (bottom) thermal resistance	N/A	N/A	

- (1) For more information about traditional and new thermal metrics, see the *IC Package Thermal Metrics* application report, [SPRA953](#).

## 6.5 Electrical Characteristics

At  $T_A = -40^\circ\text{C}$  to  $125^\circ\text{C}$ ,  $AVDD = 3\text{ V}$ ,  $DVDD = 1.65\text{ V}$  to  $3.6\text{ V}$ ,  $f_{\text{SAMPLE}} = 1\text{ MSPS}$ , unless otherwise noted.

PARAMETER		TEST CONDITIONS	MIN	TYP	MAX	UNIT
<b>ANALOG INPUT</b>						
Full-scale input voltage span			$-AVDD / 2$		$AVDD / 2$	V
Absolute input voltage range	AINP to GND		-0.1		$AVDD + 0.1$	V
	AINM to GND		$AVDD / 2 - 0.1$		$AVDD / 2 + 0.1$	V
$C_S$	Sampling capacitance			15		pF
<b>SYSTEM PERFORMANCE</b>						
Resolution				12		Bits
NMC	No missing codes		12			Bits
INL	Integral nonlinearity	$AVDD = 3\text{ V}$	-1	$\pm 0.7$	1	LSB
		$AVDD = 1.8\text{ V}$	-2	$\pm 1$	2	LSB
DNL	Differential nonlinearity	$AVDD = 3\text{ V}$	-0.99	$\pm 0.5$	1	LSB
		$AVDD = 1.8\text{ V}$	-0.99	$\pm 0.7$	2	LSB
$E_O$	Uncalibrated offset error	$AVDD = 1.8\text{ V}$ to $3.6\text{ V}$		$\pm 12$		LSB
	Calibrated offset error	$AVDD = 3\text{ V}$	-3	$\pm 0.5$	3	LSB
		$AVDD = 1.8\text{ V}$	-4	$\pm 1$	4	LSB
$dV_{OS}/dT$	Offset error drift with temperature			5		ppm/ $^\circ\text{C}$
$E_G$	Gain error	$AVDD = 3\text{ V}$	-0.1	$\pm 0.05$	0.1	%FS
		$AVDD = 1.8\text{ V}$	-0.2	$\pm 0.1$	0.2	%FS
	Gain error drift with temperature			2		ppm/ $^\circ\text{C}$
<b>SAMPLING DYNAMICS</b>						
$t_{ACQ}$	Acquisition time		200			ns
	Maximum throughput rate	16-MHz SCLK, $AVDD = 1.8\text{ V}$ to $3.6\text{ V}$			1	MHz
<b>DYNAMIC CHARACTERISTICS</b>						
SNR	Signal-to-noise ratio	$f_{IN} = 2\text{ kHz}$ , $AVDD = 3\text{ V}$	69	70		dB
		$f_{IN} = 2\text{ kHz}$ , $AVDD = 1.8\text{ V}$		68		dB
THD	Total harmonic distortion	$f_{IN} = 2\text{ kHz}$ , $AVDD = 3\text{ V}$		-80		dB
SINAD	Signal-to-noise and distortion	$f_{IN} = 2\text{ kHz}$ , $AVDD = 3\text{ V}$	68	69.5		dB
		$f_{IN} = 2\text{ kHz}$ , $AVDD = 1.8\text{ V}$		67.5		dB
SFDR	Spurious-free dynamic range	$f_{IN} = 2\text{ kHz}$ , $AVDD = 3\text{ V}$		85		dB
$BW_{(fp)}$	Full-power bandwidth	At -3 dB, $AVDD = 3\text{ V}$		25		MHz
<b>DIGITAL INPUT/OUTPUT (CMOS Logic Family)</b>						
$V_{IH}$	High-level input voltage		0.65 DVDD		$DVDD + 0.3$	V
$V_{IL}$	Low-level input voltage		-0.3		0.35 DVDD	V
$V_{OH}$	High-level output voltage	At $I_{source} = 500\ \mu\text{A}$	0.8 DVDD		DVDD	V
		At $I_{source} = 2\text{ mA}$	$DVDD - 0.45$		DVDD	V
$V_{OL}$	Low-level output voltage	At $I_{sink} = 500\ \mu\text{A}$	0		0.2 DVDD	V
		At $I_{sink} = 2\text{ mA}$	0		0.45	V
<b>POWER-SUPPLY REQUIREMENTS</b>						
AVDD	Analog supply voltage		1.8	3	3.6	V
DVDD	Digital I/O supply voltage		1.65	3	3.6	V
$I_{AVDD}$	Analog supply current	At 1 MSPS with $AVDD = 3\text{ V}$			260	$\mu\text{A}$
		At 100 kSPS with $AVDD = 3\text{ V}$			26	$\mu\text{A}$
		At 1 MSPS with $AVDD = 1.8\text{ V}$		135		$\mu\text{A}$
$P_D$	Power dissipation	At 1 MSPS with $AVDD = 3\text{ V}$			780	$\mu\text{W}$
		At 100 kSPS with $AVDD = 3\text{ V}$			78	$\mu\text{W}$
		At 1 MSPS with $AVDD = 1.8\text{ V}$		243		$\mu\text{W}$

### 6.6 Timing Characteristics

All specifications are at  $T_A = -40^{\circ}\text{C}$  to  $125^{\circ}\text{C}$ ,  $\text{AVDD} = 1.8\text{ V}$  to  $3.6\text{ V}$ , and  $\text{DVDD} = 1.65\text{ V}$  to  $3.6\text{ V}$ , unless otherwise specified.

PARAMETER		MIN	TYP	MAX	UNIT
<b>TIMING SPECIFICATIONS</b>					
$f_{\text{THROUGHPUT}}$	Throughput			1	MSPS
$t_{\text{CYCLE}}$	Cycle time	1			$\mu\text{s}$
$t_{\text{CONV}}$	Conversion time		$12.5 \times t_{\text{SCLK}} + t_{\text{SU\_CSCK}}$		ns
$t_{\text{DV\_CSDO}}$	Delay time: $\overline{\text{CS}}$ falling to data enable			10	ns
$t_{\text{D\_CKDO}}$	Delay time: SCLK falling to (next) data valid on DOUT			30	ns
$t_{\text{DZ\_CSDO}}$	Delay time: $\overline{\text{CS}}$ rising to DOUT going to 3-state	5			ns
<b>TIMING REQUIREMENTS</b>					
$t_{\text{ACQ}}$	Acquisition time	200			ns
$f_{\text{SCLK}}$	SCLK frequency			16	MHz
$t_{\text{SCLK}}$	SCLK period	62.5			ns
$t_{\text{PH\_CK}}$	SCLK high time	0.45		0.55	$t_{\text{SCLK}}$
$t_{\text{PL\_CK}}$	SCLK low time	0.45		0.55	$t_{\text{SCLK}}$
$t_{\text{PH\_CS}}$	$\overline{\text{CS}}$ high time	60			ns
$t_{\text{SU\_CSCK}}$	Setup time: $\overline{\text{CS}}$ falling to SCLK falling	15			ns
$t_{\text{D\_CKCS}}$	Delay time: last SCLK falling to $\overline{\text{CS}}$ rising	10			ns

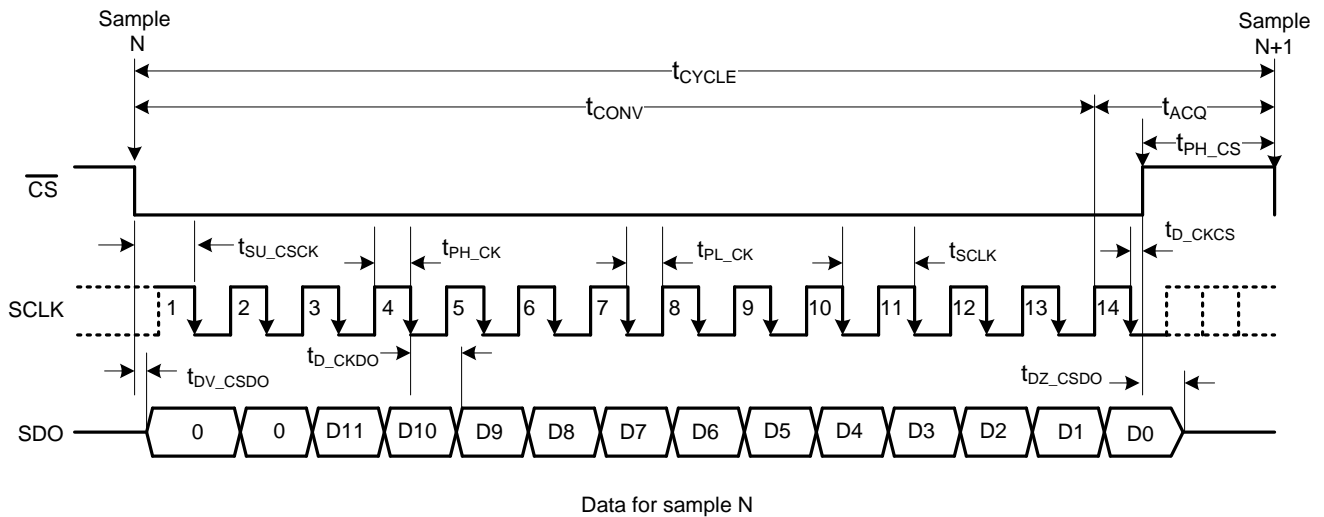

Figure 1. Timing Diagram

### 6.7 Typical Characteristics

At  $T_A = 25^\circ\text{C}$ ,  $AVDD = 3\text{ V}$ ,  $DVDD = 1.8\text{ V}$ , and  $f_{\text{SAMPLE}} = 1\text{ MSPS}$ , unless otherwise noted.

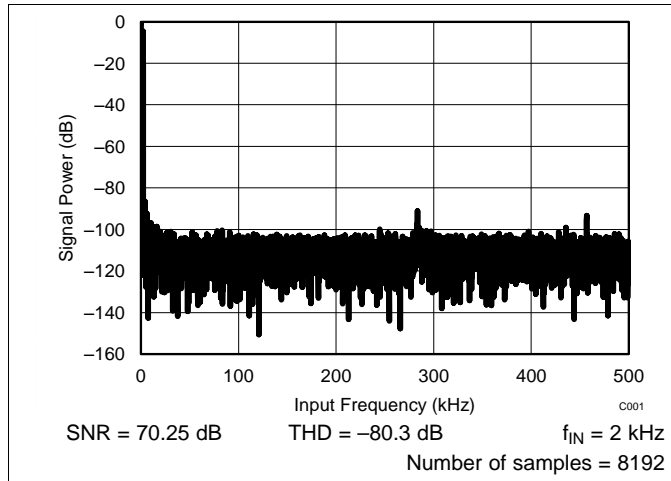

Figure 2. Typical FFT

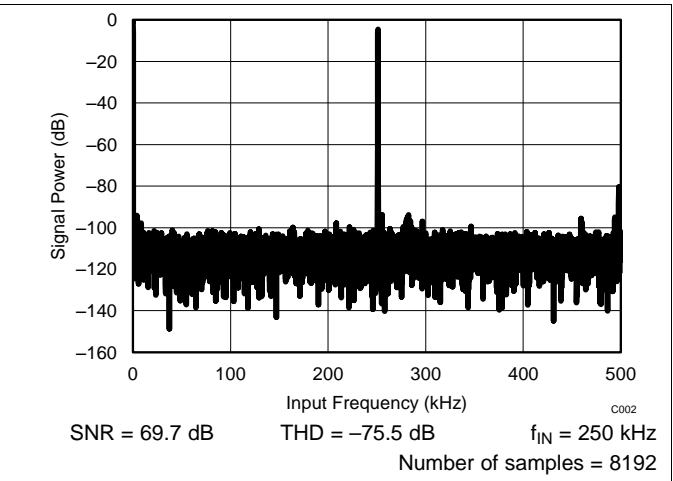

Figure 3. Typical FFT

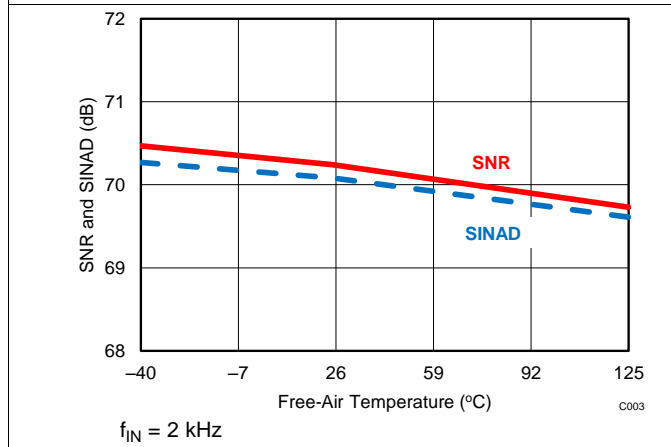

Figure 4. SNR and SINAD vs Temperature

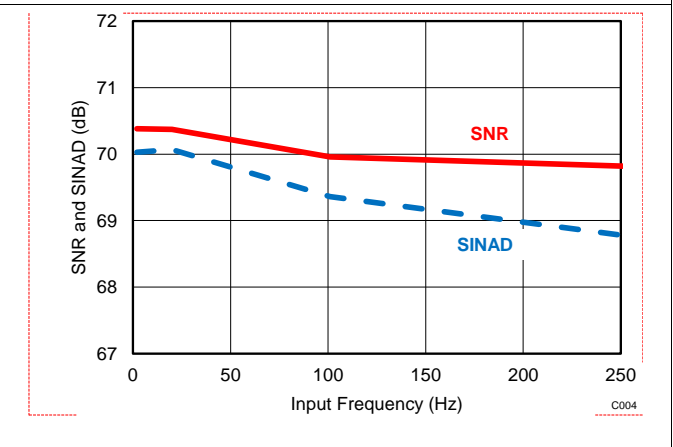

Figure 5. SNR and SINAD vs Input Frequency

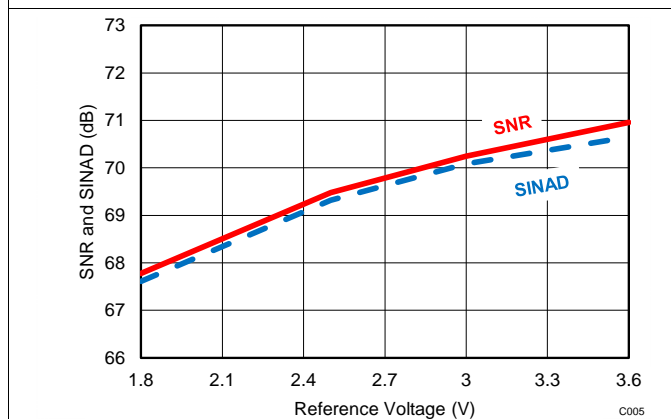

Figure 6. SNR and SINAD vs Reference Voltage (AVDD)

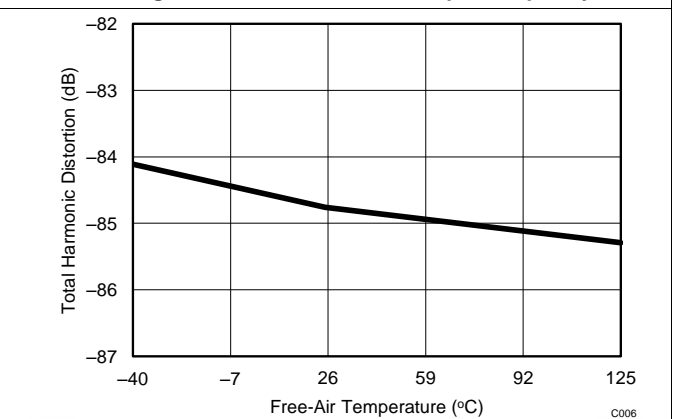
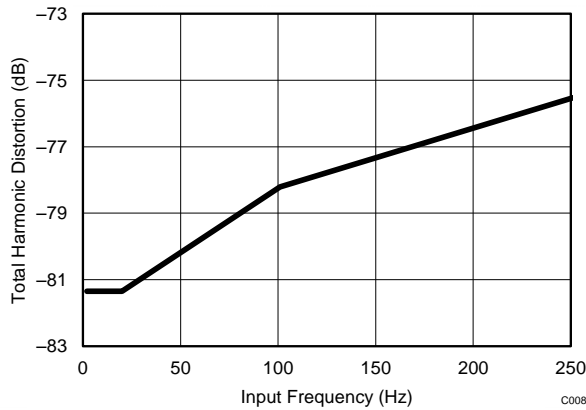

Figure 7. THD vs Free-Air Temperature

**Typical Characteristics (continued)**

At  $T_A = 25^\circ\text{C}$ ,  $AVDD = 3\text{ V}$ ,  $DVDD = 1.8\text{ V}$ , and  $f_{\text{SAMPLE}} = 1\text{ MSPS}$ , unless otherwise noted.



**Figure 8. THD vs Input Frequency**

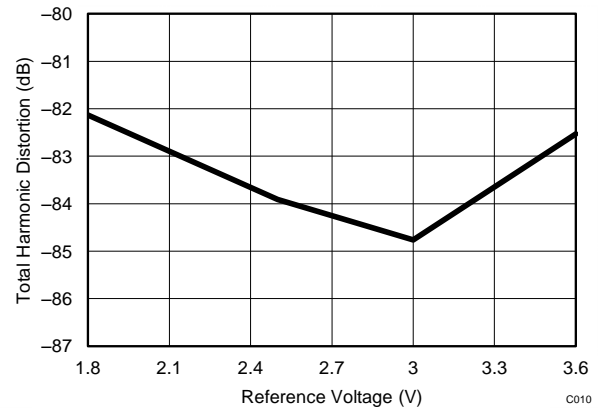

**Figure 9. THD vs Reference Voltage (AVDD)**

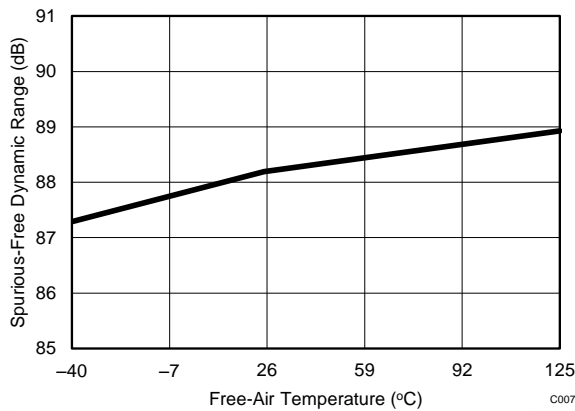

**Figure 10. SFDR vs Free-Air Temperature**

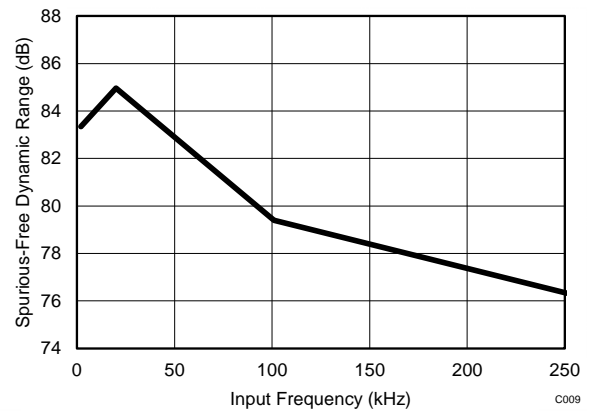

**Figure 11. SFDR vs Input Frequency**

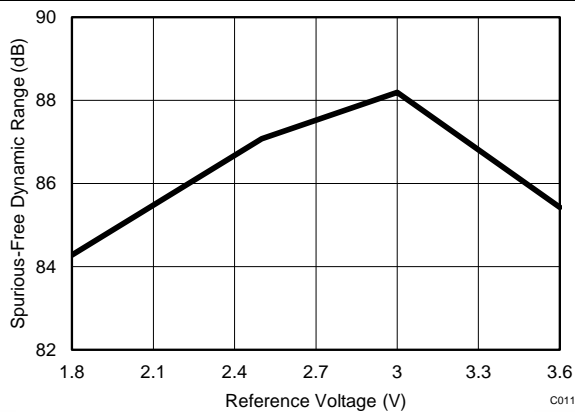

**Figure 12. SFDR vs Reference Voltage (AVDD)**

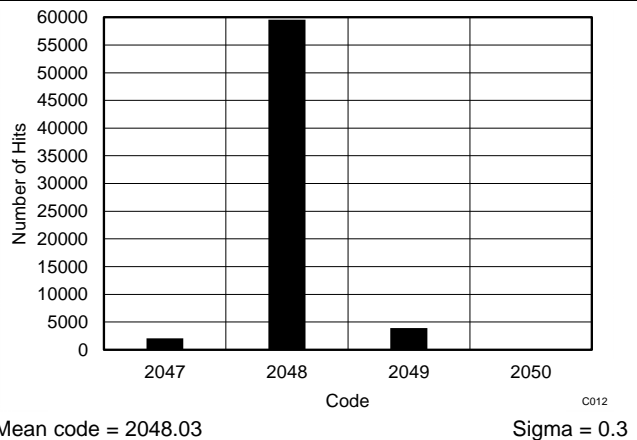

**Figure 13. DC Input Histogram**

Typical Characteristics (continued)

At  $T_A = 25^\circ\text{C}$ ,  $AVDD = 3\text{ V}$ ,  $DVDD = 1.8\text{ V}$ , and  $f_{\text{SAMPLE}} = 1\text{ MSPS}$ , unless otherwise noted.

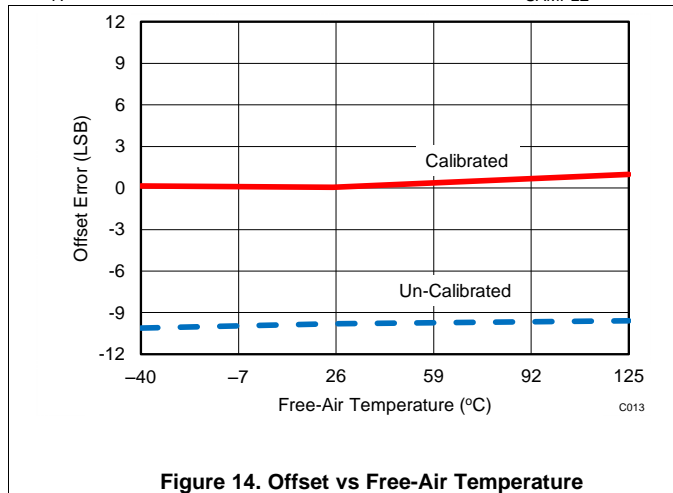

Figure 14. Offset vs Free-Air Temperature

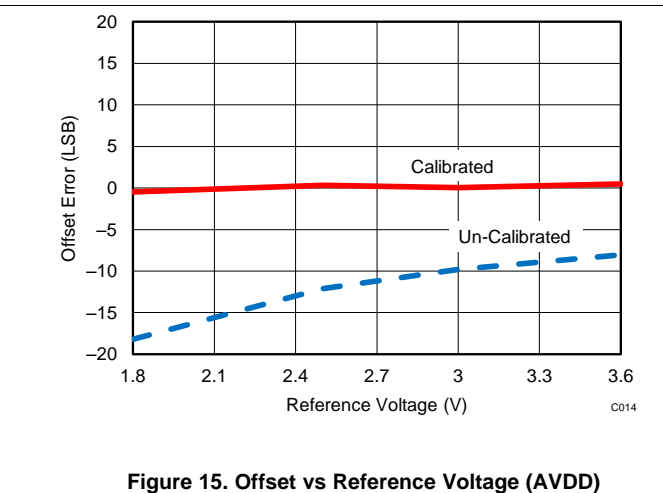

Figure 15. Offset vs Reference Voltage (AVDD)

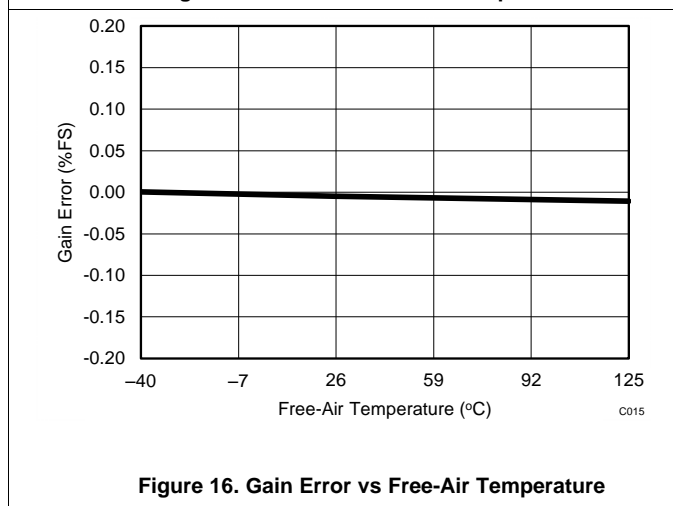

Figure 16. Gain Error vs Free-Air Temperature

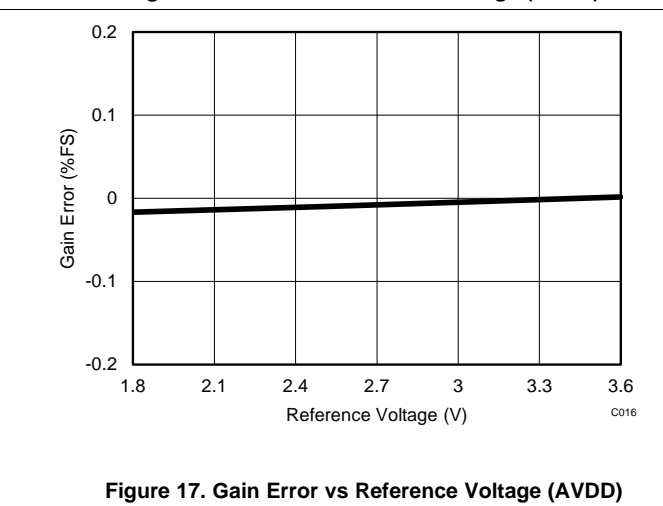

Figure 17. Gain Error vs Reference Voltage (AVDD)

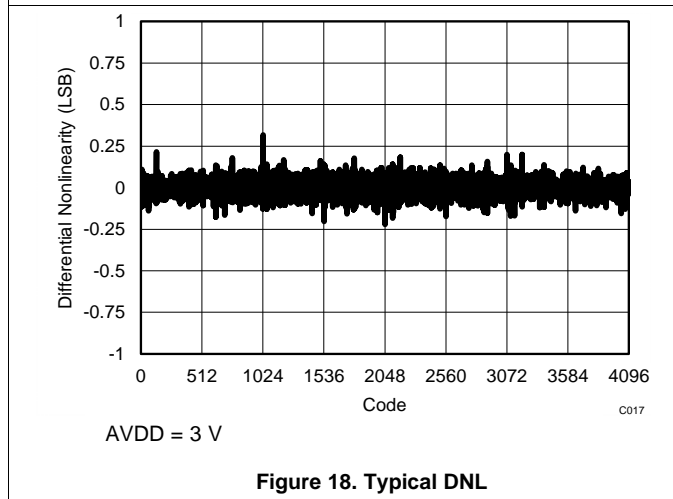

Figure 18. Typical DNL

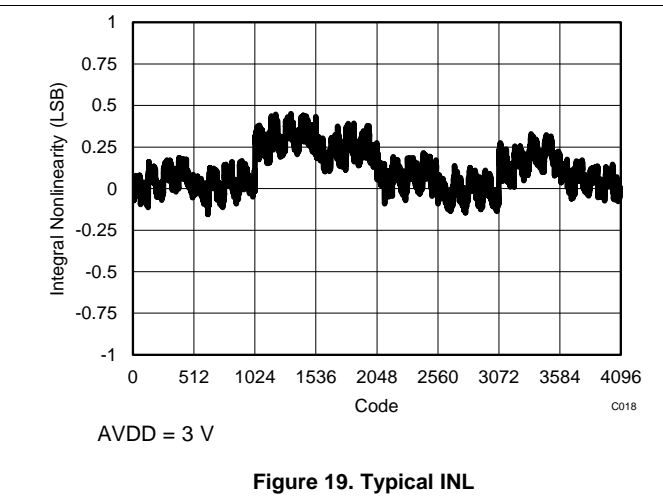
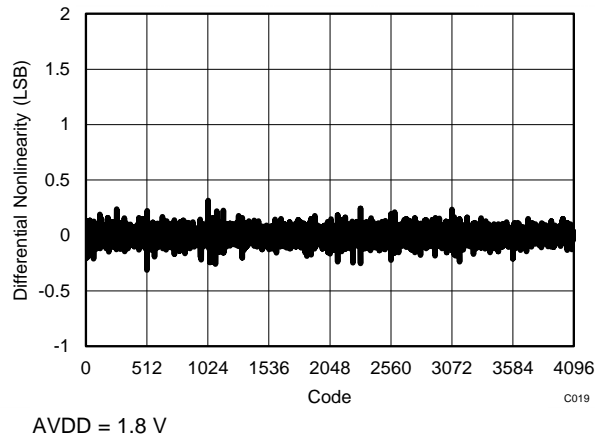

Figure 19. Typical INL

**Typical Characteristics (continued)**

At  $T_A = 25^\circ\text{C}$ ,  $AVDD = 3\text{ V}$ ,  $DVDD = 1.8\text{ V}$ , and  $f_{\text{SAMPLE}} = 1\text{ MSPS}$ , unless otherwise noted.



**Figure 20. Typical DNL**

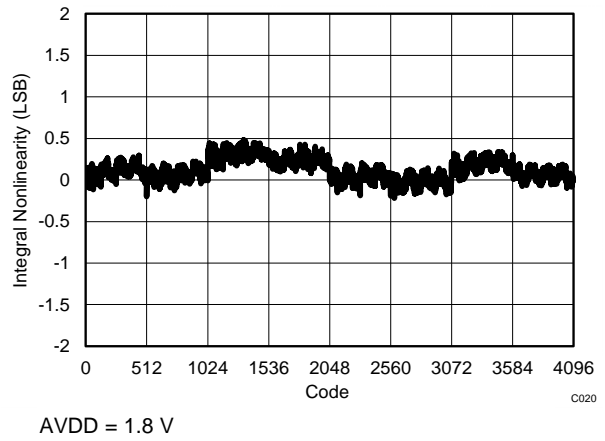

**Figure 21. Typical INL**

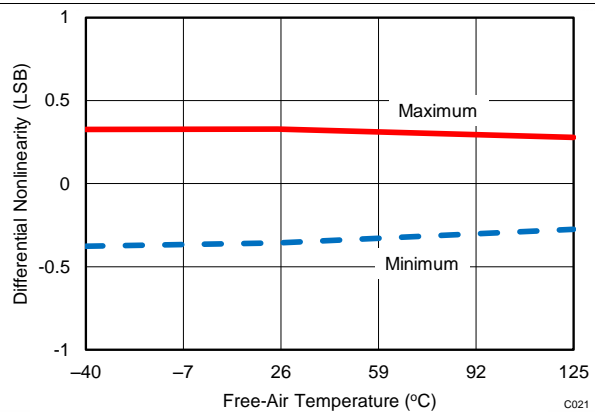

**Figure 22. DNL vs Free-Air-Temperature**

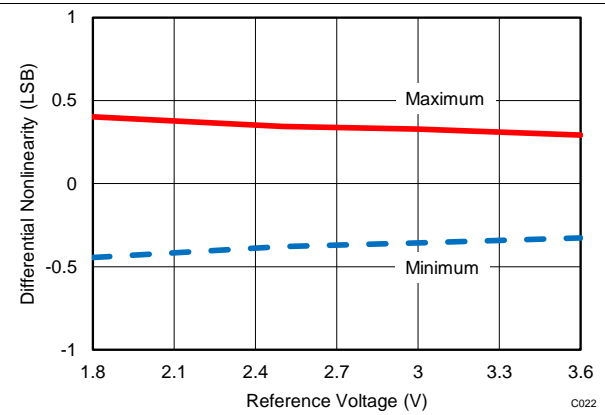

**Figure 23. DNL vs Reference Voltage (AVDD)**

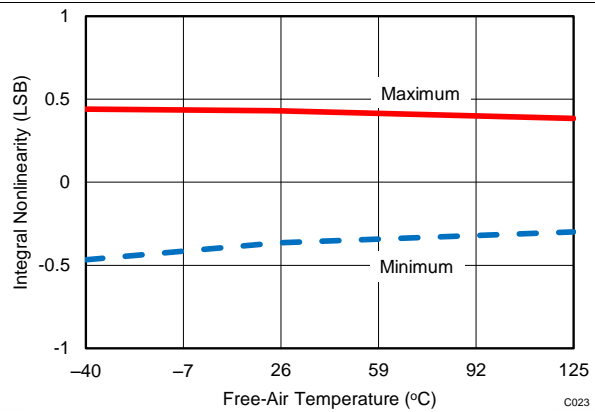

**Figure 24. INL vs Free-Air-Temperature**

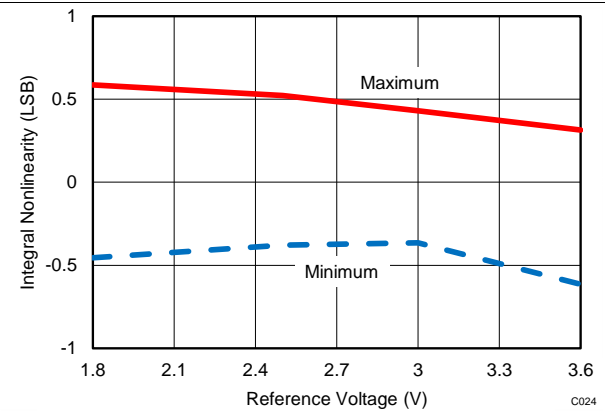

**Figure 25. INL vs Reference Voltage (AVDD)**

Typical Characteristics (continued)

At  $T_A = 25^\circ\text{C}$ ,  $AVDD = 3\text{ V}$ ,  $DVDD = 1.8\text{ V}$ , and  $f_{\text{SAMPLE}} = 1\text{ MSPS}$ , unless otherwise noted.

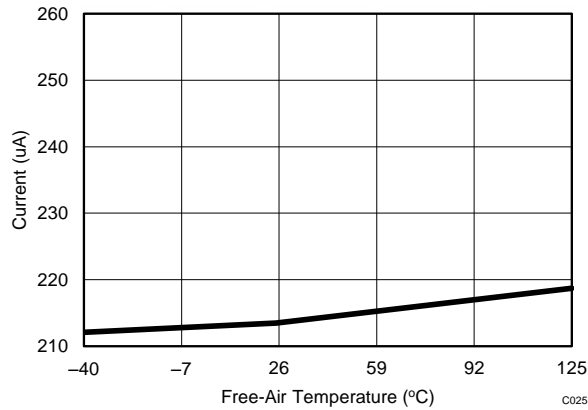

Figure 26. Supply Current vs Free-Air Temperature

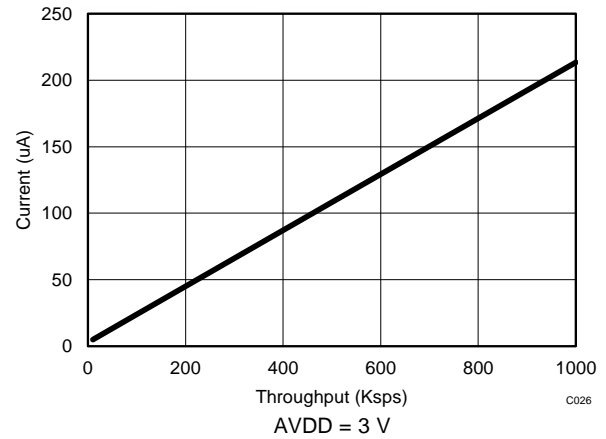

Figure 27. Supply Current vs Throughput

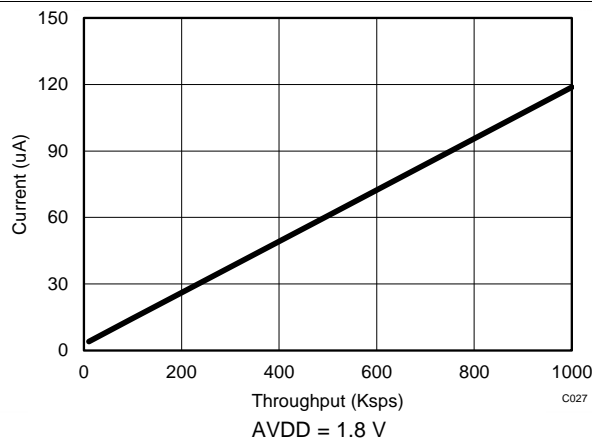

Figure 28. Supply Current vs Throughput

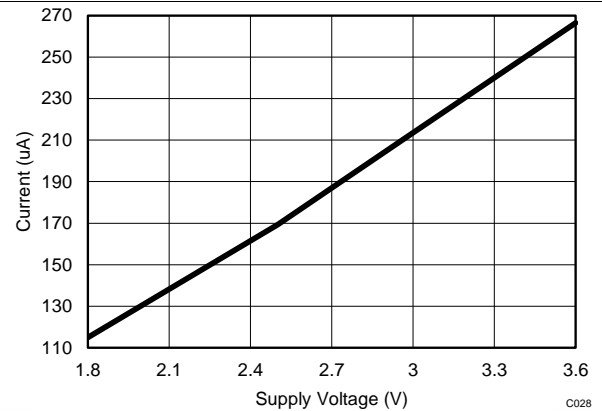

Figure 29. Supply Current vs AVDD

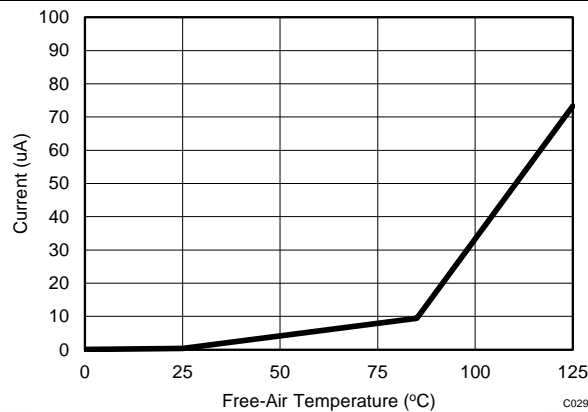

Figure 30. Static Current vs Free-Air Temperature

## 7 Parameter Measurement Information

### 7.1 Digital Voltage Levels

The device complies with the JESD8-7A standard for DVDD from 1.65 V to 1.95 V. Figure 31 shows voltage levels for the digital input and output pins.

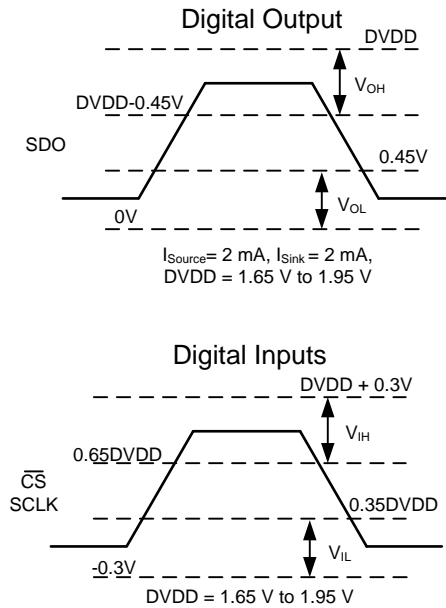

Figure 31. Digital Voltage Levels as per the JESD8-7A Standard

## 8 Detailed Description

### 8.1 Overview

The ADS7043 is an ultralow-power, ultra-small analog-to-digital converter (ADC) that supports a wide analog input range. The analog input range for the device is defined by the AVDD supply voltage. The device samples the input voltage across the AINP and AINM pins on the  $\overline{CS}$  falling edge and starts the conversion. The clock provided on the SCLK pin is used for conversion and data transfer. During conversions, both the AINP and AINM pins are disconnected from the sampling circuit. After the conversion completes, the sampling capacitors are reconnected across the AINP and AINM pins and the device enters acquisition phase.

The device has an internal offset calibration. The offset calibration can be initiated by the user either on power-up or during normal operation; see the [Offset Calibration](#) section for more details.

The device also provides a simple serial interface to the host controller and operates over a wide range of digital power supplies. The device requires only a 16-MHz SCLK for supporting a throughput of 1 MSPS. The digital interface also complies with the JESD8-7A (normal range) standard. The [Functional Block Diagram](#) section provides a block diagram of the device.

### 8.2 Functional Block Diagram

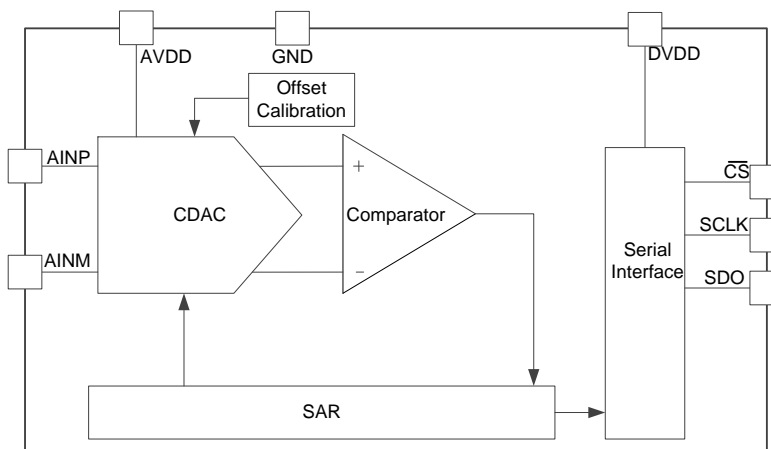

## 8.3 Feature Description

### 8.3.1 Reference

The device uses the analog supply voltage (AVDD) as a reference. The AVDD pins must be decoupled with a 1- $\mu$ F, low equivalent series resistance (ESR), ceramic capacitor, as shown in [Figure 32](#). The AVDD pin functions as a switched capacitor load to the source powering AVDD. The decoupling capacitor provides the instantaneous charge required by the internal circuit and helps in maintaining a stable dc voltage on the AVDD pin. TI recommends powering the AVDD pin with a low output impedance and low-noise regulator (such as the [TPS79101](#)).

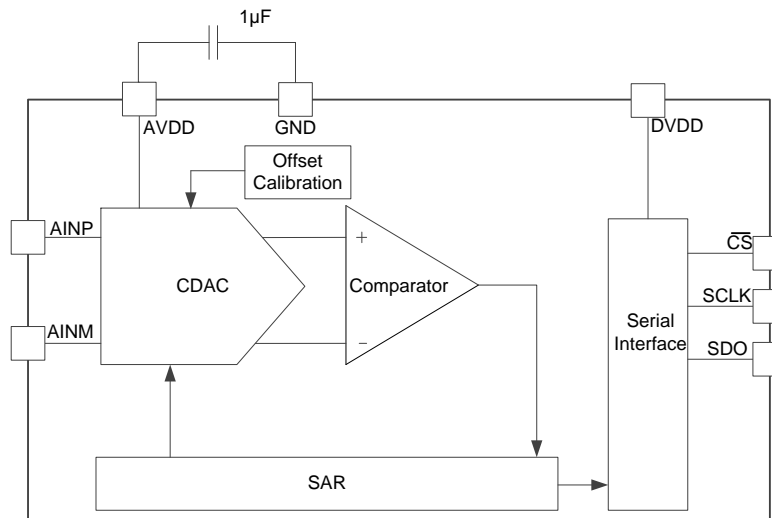
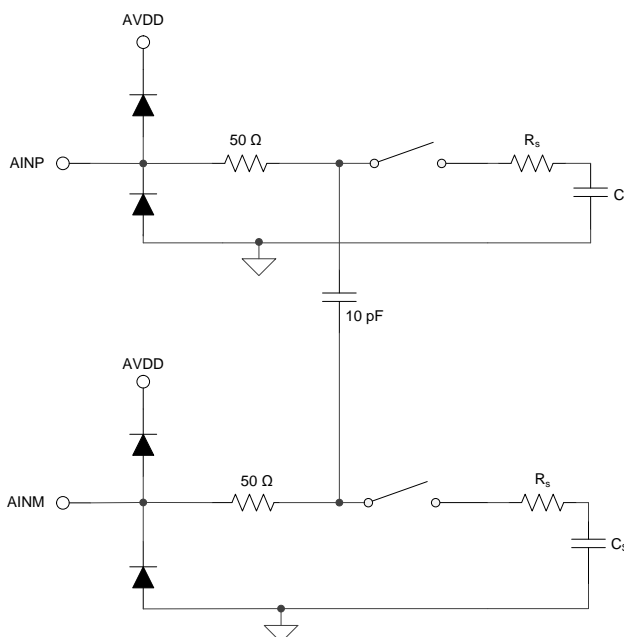

**Figure 32. Reference for the Device**

## Feature Description (continued)

### 8.3.2 Analog Input

The device supports pseudo-differential analog inputs. The ADC samples the difference between AINP and AINM and converts for this voltage. The device is capable of accepting a signal from  $AVDD / 2 - 100 \text{ mV}$  to  $AVDD / 2 + 100 \text{ mV}$  on the AINM input and a signal from 0 V to AVDD on the AINP input. Figure 33 represents the equivalent analog input circuits for the sampling stage. The device has a low-pass filter followed by the sampling switch and sampling capacitor. The sampling switch is represented by an  $R_s$  (typically  $50 \Omega$ ) resistor in series with an ideal switch and  $C_s$  (typically  $15 \text{ pF}$ ) is the sampling capacitor. The ESD diodes are connected from both analog inputs to AVDD and ground.



**Figure 33. Equivalent Input Circuit for the Sampling Stage**

The analog input full-scale range (FSR) is defined by the reference voltage of the ADC. The relationship between the FSR and the reference voltage can be determined by:  $FSR = V_{REF} = AVDD$ .

### 8.3.3 ADC Transfer Function

The device output is in straight binary format. The device resolution can be computed by Equation 1:

$$1 \text{ LSB} = FSR / 2^N$$

where:

- $FSR = V_{REF} = AVDD$  and
- $N = 12$

(1)

**Feature Description (continued)**

Figure 34 and Table 1 show the ideal transfer characteristics for the device.

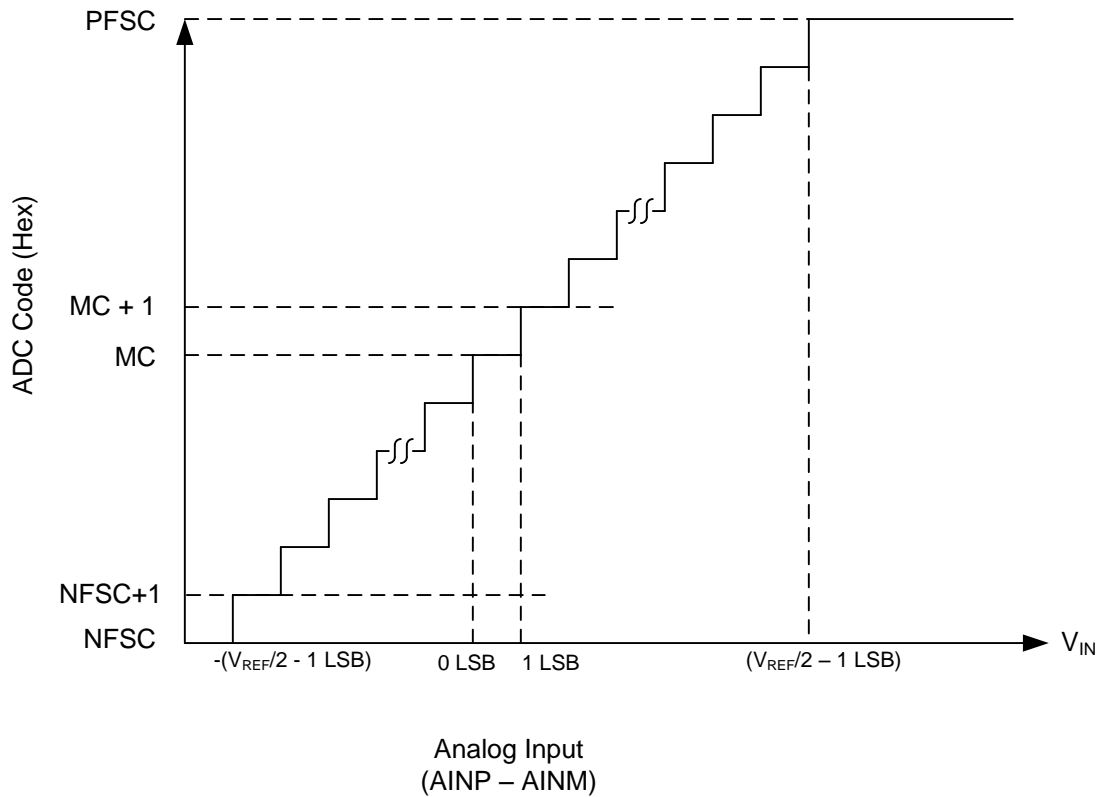

**Figure 34. Ideal Transfer Characteristics**

**Table 1. Transfer Characteristics**

INPUT VOLTAGE (AINP-AINM)	CODE	DESCRIPTION	IDEAL OUTPUT CODE
$\leq -(V_{REF}/2 - 1 \text{ LSB})$	NFSC	Negative full-scale code	000
$-(V_{REF}/2 - 1 \text{ LSB})$ to $-(V_{REF}/2 - 2 \text{ LSBs})$	NFSC + 1	—	001
0 to 1 LSB	MC	Mid code	800
1 LSB to 2 LSBs	MC + 1	—	801
$\geq V_{REF}/2 - 1 \text{ LSB}$	PFSC	Positive full-scale code	FFF

### 8.3.4 Serial Interface

The device supports a simple, SPI-compatible interface to the external host. The  $\overline{CS}$  signal defines one conversion and serial transfer frame. A frame starts with a  $\overline{CS}$  falling edge and ends with a  $\overline{CS}$  rising edge. The SDO pin outputs the ADC conversion results. Figure 35 shows a detailed timing diagram for the serial interface. A minimum delay of  $t_{SU\_CSCK}$  must elapse between the  $\overline{CS}$  falling edge and the first SCLK falling edge. The device uses the clock provided on the SCLK pin for conversion and data transfer. The conversion result is available on the SDO pin with the first two bits set to 0, followed by 12 bits of the conversion result. The last bit (bit 0) is shifted out of SDO on the 14th SCLK falling edge. The SDO output remains low after the 14th SCLK falling edge if more than 14 SCLKs are provided in one serial transfer frame. A  $\overline{CS}$  rising edge ends the frame and brings the serial data bus to 3-state. For the acquisition of next sample, a minimum time of  $t_{ACQ}$  must be provided after the conversion of current sample is completed.

The device initiates offset calibration on first  $\overline{CS}$  falling edge after power-up and the SDO output remains low during the first serial transfer frame after power-up. For details, refer to the [Offset Calibration](#) section.

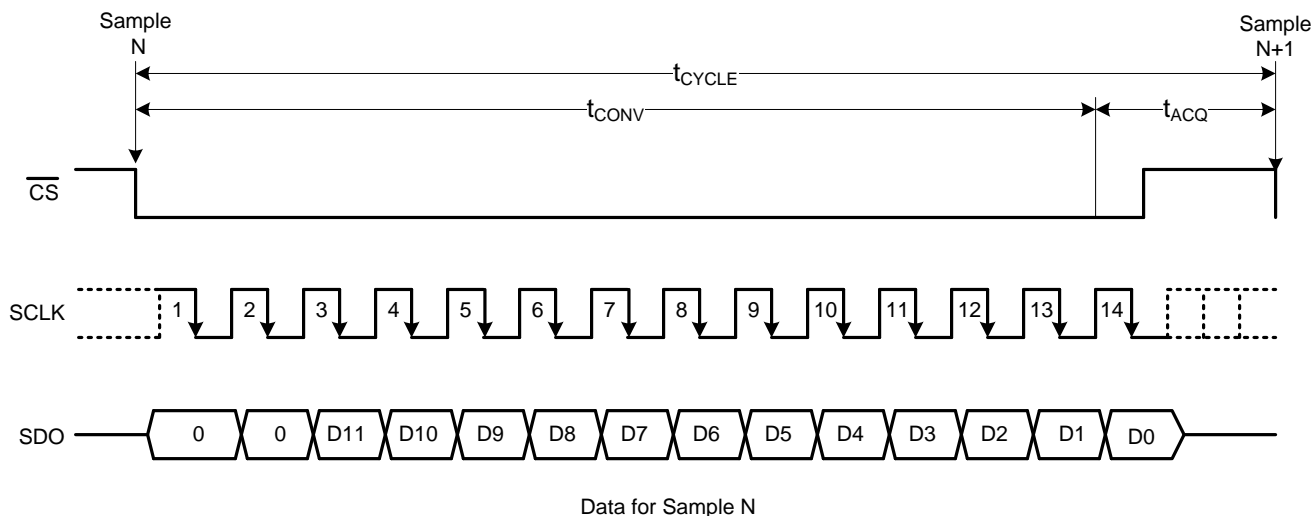

Figure 35. Serial Interface Timing Diagram

## 8.4 Device Functional Modes

### 8.4.1 Offset Calibration

The device includes a feature to calibrate its internal offset. The device initiates offset calibration on the first  $\overline{CS}$  falling edge after power up and during offset calibration, the analog input pins (AINP and AINM) are disconnected from the sampling stage. After the first serial transfer frame, the device starts operating with either uncalibrated or calibrated offset, depending on the number of SCLKs provided in the first serial transfer frame. Offset calibration can also be initiated by the user during normal operation. Figure 36 shows the offset calibration process. The SDO output remains low during the first serial transfer frame.

The device includes an internal offset calibration register (OCR) that stores the offset calibration result. The OCR is an internal register and cannot be accessed by the user through the serial interface. The OCR is reset to zero on power-up. Therefore, TI recommends calibrating the offset on power-up to bring the offset within the specified limits. If there is a significant change in operating temperature or analog supply voltage, the offset can be recalibrated during normal operation.

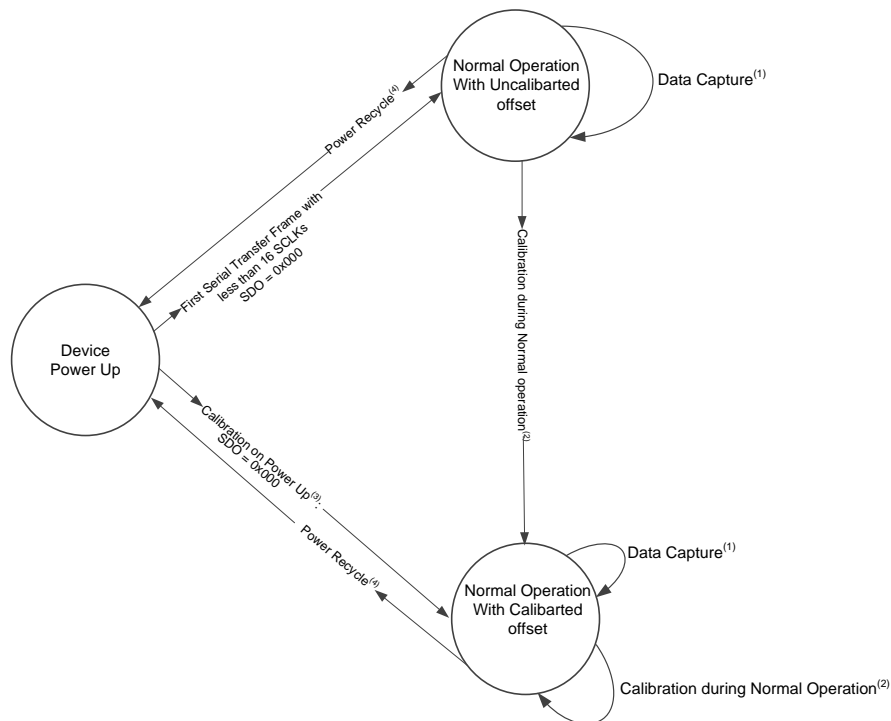

- (1) See the [Timing Characteristics](#) section for timing specifications.
- (2) See the [Offset Calibration During Normal Operation](#) section for details.
- (3) See the [Offset Calibration on Power-Up](#) section for details.
- (4) The power recycle on the AVDD supply is required to reset the offset calibration and to bring the device to a power-up state.

**Figure 36. Offset Calibration**

## Device Functional Modes (continued)

### 8.4.1.1 Offset Calibration on Power-Up

The device starts offset calibration on the first  $\overline{CS}$  falling edge after power-up and calibration completes if the  $\overline{CS}$  pin remains low for at least 16 SCLKs after the first  $\overline{CS}$  falling edge. The SDO output remains low during calibration. The minimum acquisition time must be provided after calibration for acquiring the first sample. If the device is not provided with at least 16 SCLKs during the first serial transfer frame after power-up, the OCR is not updated. Table 2 provides the timing parameters for offset calibration on power-up.

For subsequent samples, the device adjusts the conversion results with the value stored in the OCR. The conversion result adjusted with the value stored in OCR is provided by the device on the SDO output. Figure 37 illustrates the timing diagram for offset calibration on power-up.

Table 2. Offset Calibration on Power-Up

PARAMETER	MIN	TYP	MAX	UNIT
$f_{CLK-CAL}$ SCLK frequency for calibration at $2.25\text{ V} < AVDD < 3.6\text{ V}$			16	MHz
$f_{CLK-CAL}$ SCLK frequency for calibration at $1.8\text{ V} < AVDD < 2.25\text{ V}$			12	MHz
$t_{POWERUP-CAL}$ Calibration time at power-up	16 $t_{SCLK}$			ns
$t_{ACQ}$ Acquisition time	200			ns
$t_{PH\_CS}$ $\overline{CS}$ high time	$t_{ACQ}$			ns

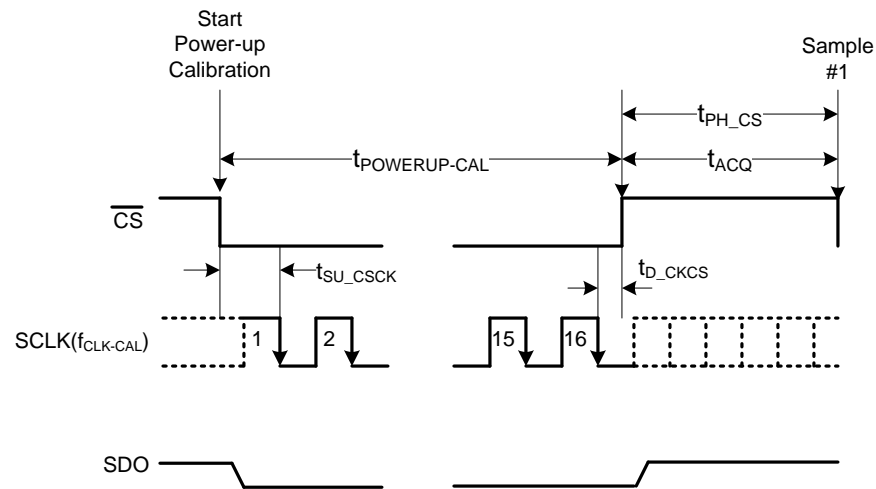

Figure 37. Offset Calibration on Power-Up Timing Diagram

**8.4.1.2 Offset Calibration During Normal Operation**

The offset can also be calibrated during normal device operation. Offset calibration can be done during normal device operation if at least 32 SCLKs are provided in one serial transfer frame. During the first 14 SCLKs, the device converts the sample acquired on the  $\overline{CS}$  falling edge and provides data on the SDO output. The device initiates the offset calibration on the 17th SCLK falling edge and calibration is completed on the 32nd SCLK falling edge. The SDO output remains low after the 14th SCLK falling edge and SDO goes to tri-state after  $\overline{CS}$  goes high. If the device is provided with less than 32 SCLKs during a serial transfer frame, the OCR is not updated. Table 3 provides the timing parameters for offset calibration during normal operation.

For subsequent samples, the device adjusts the conversion results with the value stored in OCR. The conversion result adjusted with the value stored in the OCR is provided by the device on the SDO output. Figure 38 illustrates the timing diagram for offset calibration during normal operation.

**Table 3. Offset Calibration During Normal Operation**

PARAMETER	MIN	TYP	MAX	UNIT
$f_{CLK-CAL}$ SCLK frequency for calibration for 2.25 V < AVDD < 3.6 V			16	MHz
$f_{CLK-CAL}$ SCLK frequency for calibration for 1.8 V < AVDD < 2.25 V			12	MHz
$t_{CAL}$ Calibration time during normal operation	16 $t_{SCLK}$			ns
$t_{ACQ}$ Acquisition time	200			ns
$t_{PH\_CS}$ $\overline{CS}$ high time	$t_{ACQ}$			ns

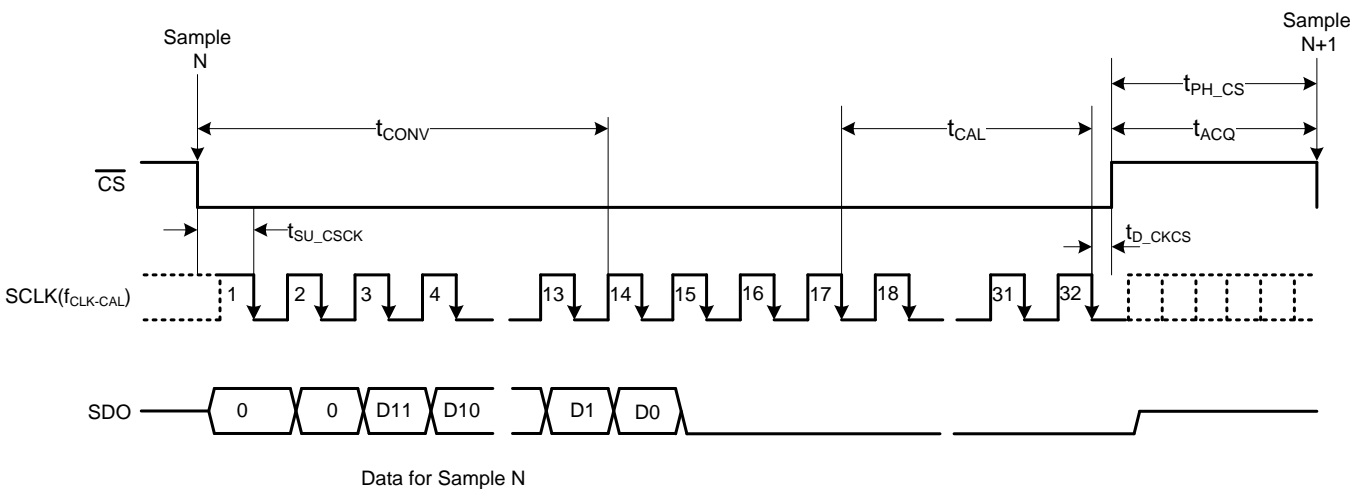

**Figure 38. Offset Calibration During Normal Operation Timing Diagram**

## 9 Application and Implementation

### NOTE

Information in the following applications sections is not part of the TI component specification, and TI does not warrant its accuracy or completeness. TI's customers are responsible for determining suitability of components for their purposes. Customers should validate and test their design implementation to confirm system functionality.

### 9.1 Application Information

The two primary circuits required to maximize the performance of a high-precision, successive approximation register (SAR), analog-to-digital converter (ADC) are the input driver and the reference driver circuits. This section details some general principles for designing the input driver circuit, reference driver circuit, and provides some application circuits designed for the ADS7043.

### 9.2 Typical Applications

#### 9.2.1 Single-Supply DAQ with the ADS7043

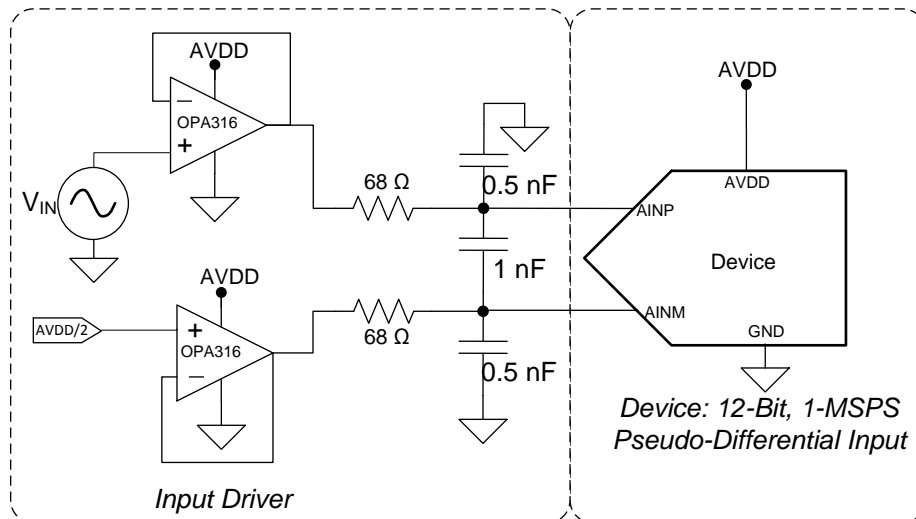

Figure 39. DAQ Circuit: Single-Supply DAQ

##### 9.2.1.1 Design Requirements

The goal of this application is to design a single-supply digital acquisition (DAQ) circuit based on the ADS7043 with SNR greater than 69 dB and THD less than  $-80$  dB for a input signal having an amplitude of  $AVDD / 2$  with a common-mode voltage of  $AVDD / 2$  and input frequencies of 2 kHz at a throughput of 1 MSPS.

##### 9.2.1.2 Detailed Design Procedure

The input driver circuit for a high-precision ADC mainly consists of two parts: a driving amplifier and an antialiasing filter. Careful design of the front-end circuit is critical to meet the linearity and noise performance of a high-precision ADC.

## Typical Applications (continued)

### 9.2.1.2.1 Antialiasing Filter

Converting analog-to-digital signals requires sampling an input signal at a rate greater than or equal to the Nyquist rate. Any higher frequency content in the input signal beyond half the sampling frequency is digitized and folded back into the low-frequency spectrum. This process is called *aliasing*. Therefore, an external, antialiasing filter must be used to remove the harmonic content from the input signal before being sampled by the ADC. An antialiasing filter is designed as a low-pass RC filter, for which the 3-dB bandwidth is optimized for noise, response time, and throughput. For dc signals with fast transients (including multiplexed input signals), a high-bandwidth filter is designed to allow the signal to be accurately set at the ADC inputs during the small acquisition time window. Figure 40 provides the equation for determining the bandwidth of antialiasing filter.

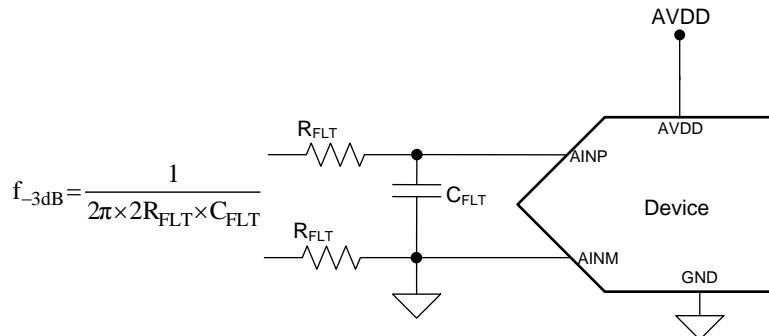

**Figure 40. Antialiasing Filter**

For ac signals, the filter bandwidth must be kept low to band limit the noise fed into the ADC input, thereby increasing the signal-to-noise ratio (SNR) of the system. Besides filtering the noise from the front-end drive circuitry, the RC filter also helps attenuate the sampling charge injection from the switched-capacitor input stage of the ADC. A filter capacitor,  $C_{FLT}$ , is connected across the ADC inputs. This capacitor helps reduce the sampling charge injection and provides a charge bucket to quickly charge the internal sample-and-hold capacitors during the acquisition process. As a rule of thumb, the value of this capacitor must be at least 20 times the specified value of the ADC sampling capacitance. For this device, the input sampling capacitance is equal to 15 pF. Thus, the value of  $C_{FLT}$  must be greater than 300 pF. The capacitor must be a COG- or NPO-type because these capacitor types have a high-Q, low-temperature coefficient, and stable electrical characteristics under varying voltages, frequency, and time.

Note that driving capacitive loads can degrade the phase margin of the input amplifiers, thus making the amplifier marginally unstable. To avoid amplifier stability issues, series isolation resistors ( $R_{FLT}$ ) are used at the output of the amplifiers. A higher value of  $R_{FLT}$  is helpful from the amplifier stability perspective, but adds distortion as a result of interactions with the nonlinear input impedance of the ADC. Distortion increases with source impedance, input signal frequency, and input signal amplitude. Therefore, the selection of  $R_{FLT}$  requires balancing the stability and distortion of the design.

The input amplifier bandwidth must be much higher than the cutoff frequency of the antialiasing filter. TI strongly recommends performing a SPICE simulation to confirm that the amplifier has more than 40° phase margin with the selected filter. Simulation is critical because even with high-bandwidth amplifiers, some amplifiers may require more bandwidth than others to drive similar filters.

## Typical Applications (continued)

### 9.2.1.2.2 Input Amplifier Selection

Selection criteria for the input amplifiers is highly dependent on the input signal type and the performance goals of the data acquisition system. Some key amplifier specifications to consider while selecting an appropriate amplifier to drive the inputs of the ADC are:

- **Small-signal bandwidth:** Select the small-signal bandwidth of the input amplifiers to be high enough to settle the input signal in the acquisition time of the ADC. Higher bandwidth reduces the closed-loop output impedance of the amplifier, thus allowing the amplifier to more easily drive the low cutoff frequency RC filter at the ADC inputs. Higher bandwidth also minimizes the harmonic distortion at higher input frequencies. In order to maintain the overall stability of the input driver circuit, select the amplifier bandwidth as described in [Equation 2](#):

$$GBW \geq 4 \times \frac{1}{2\pi \times 2R_{FLT} \times C_{FLT}}$$

where:

- GBW = Unity-gain bandwidth (2)
- **Noise:** Noise contribution of the front-end amplifiers must be low enough to prevent any degradation in SNR performance of the system. As a rule of thumb, to ensure that the noise performance of the data acquisition system is not limited by the front-end circuit, keep the total noise contribution from the front-end circuit below 20% of the input-referred noise of the ADC. Noise from the input driver circuit is band limited by designing a low cutoff frequency RC filter, as explained in [Equation 3](#).

$$N_G \times \sqrt{2} \times \sqrt{\left(\frac{V_{1/f\_AMP\_PP}}{6.6}\right)^2 + e_{n\_RMS}^2 \times \frac{\pi}{2} \times f_{-3dB}} \leq \frac{1}{5} \times \frac{V_{REF}}{2\sqrt{2}} \times 10^{-\left(\frac{SNR(dB)}{20}\right)}$$

where:

- $V_{1/f\_AMP\_PP}$  is the peak-to-peak flicker noise in  $\mu V_{rms}$ ,
- $e_{n\_RMS}$  is the amplifier broadband noise,
- $f_{-3dB}$  is the  $-3$ -dB bandwidth of the RC filter, and
- $N_G$  is the noise gain of the front-end circuit. (3)
- **Settling time:** For dc signals with fast transients that are common in a multiplexed application, the input signal must settle to the desired accuracy at the inputs of the ADC during the acquisition time window. This condition is critical to maintain the overall linearity performance of the ADC. Typically, the amplifier data sheets specify the output settling performance only up to 0.1% to 0.001%, which may not be sufficient for the desired accuracy. Therefore, always verify the settling behavior of the input driver with TINA™-SPICE simulations before selecting the amplifier.

The [OPA316](#) is selected for this application for its rail-to-rail input and output swing, low-noise (11 nV/ $\sqrt{Hz}$ ), and low-power (400  $\mu A$ ) performance to support a single-supply data acquisition circuit.

### 9.2.1.2.3 Reference Circuit

The analog supply voltage of the device is also used as a voltage reference for conversion. Therefore, decouple the AVDD pins with a 1- $\mu F$ , low-ESR ceramic capacitor close the pins of the device.



For a step-by-step design procedure, circuit schematics, bill of materials, PCB files, simulation results, and test results, refer to [TI Precision Design TIPD168, Three 12-Bit Data Acquisition Reference Designs Optimized for Low Power and Ultra-Small Form Factor \(TIDU390\)](#).

9.2.1.3 Application Curve

Figure 41 shows the FFT plot for the device with a 2-kHz input frequency for the circuit in Figure 39.

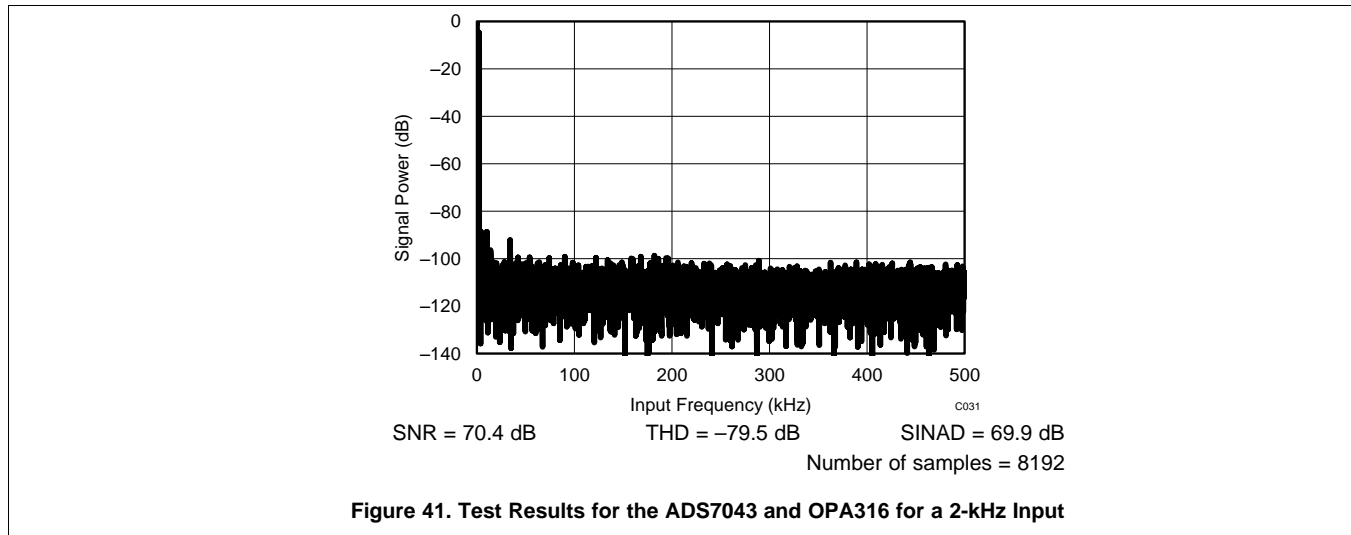

9.2.2 DAQ Circuit with the ADS7043 for Maximum SINAD at a 250-kHz  $f_{IN}$

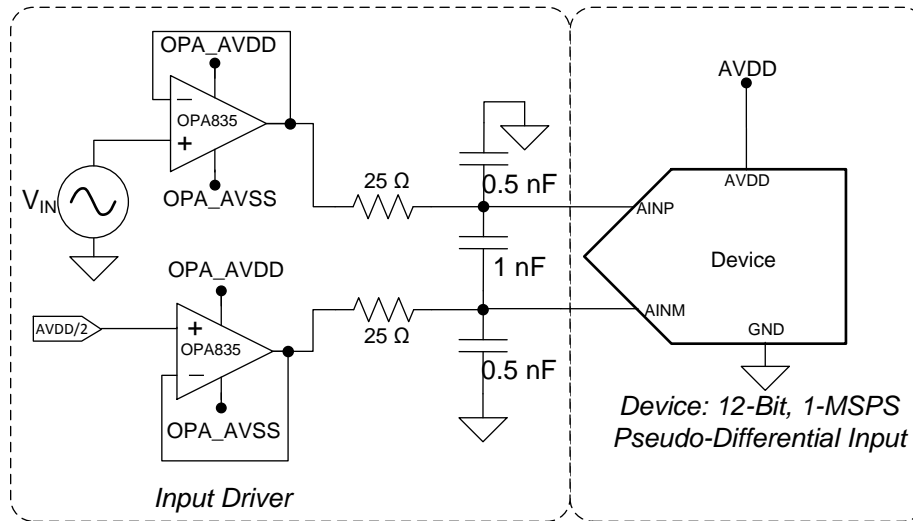

Figure 42. ADS7043 DAQ Circuit for Maximum SINAD

9.2.2.1 Design Requirements

The goal of this application is to design a data acquisition (DAQ) circuit based on the ADS7043 with SINAD greater than 68 dB for input signals having an amplitude of  $AVDD / 2$  with common-mode voltage of  $AVDD / 2$  and input frequencies up to 250 kHz.

9.2.2.2 Detailed Design Procedure

See the [Detailed Design Procedure](#) section in the [Single-Supply DAQ with the ADS7043](#) application for further details.

To achieve a SINAD of 68 dB, the operational amplifier must have high bandwidth to settle the input signal within the acquisition time of the ADC. The operational amplifier must have low noise to keep the total system noise below 20% of the input-referred noise of the ADC. For the application circuit shown in [Figure 42](#), the OPA835 is selected for its high-bandwidth (56 MHz) and low-noise ( $9.3 \text{ nV}/\sqrt{\text{Hz}}$ ) performance.

9.2.2.3 Application Curve

[Figure 43](#) shows the FFT plot for the device with a 250-kHz input frequency for the circuit shown in [Figure 42](#).

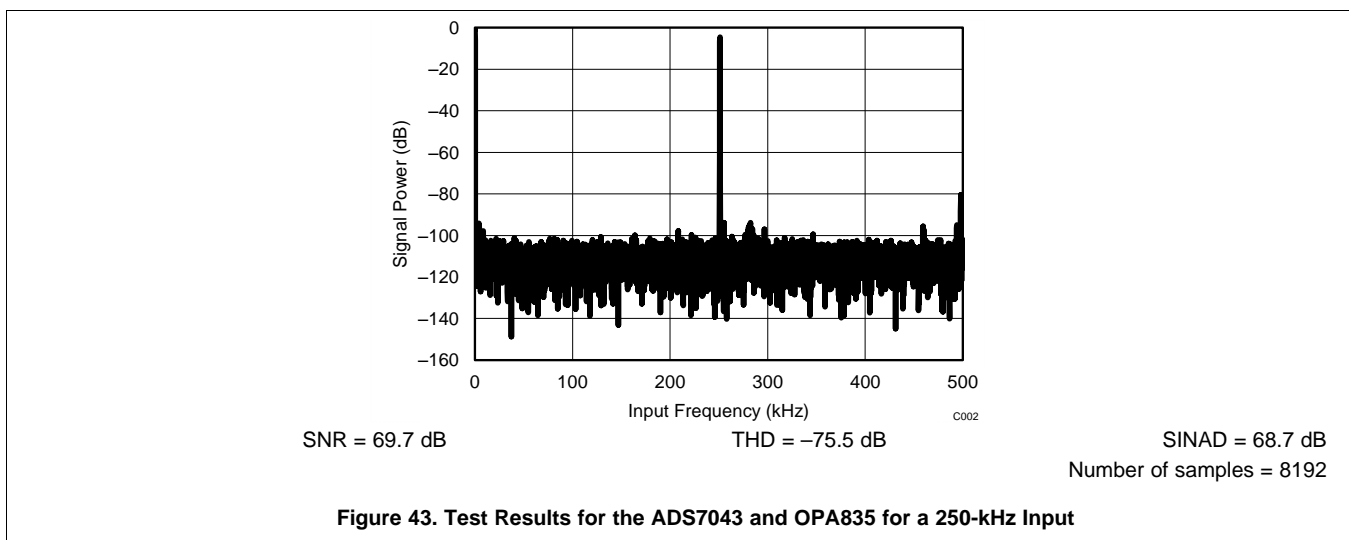
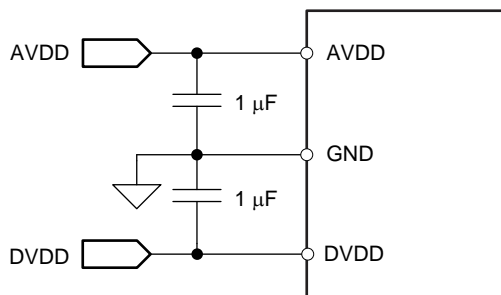

Figure 43. Test Results for the ADS7043 and OPA835 for a 250-kHz Input

## 10 Power-Supply Recommendations

### 10.1 AVDD and DVDD Supply Recommendations

The device has two separate power supplies: AVDD and DVDD. The device operates on AVDD; DVDD is used for the interface circuits. AVDD and DVDD can be independently set to any value within the permissible ranges. The AVDD supply also defines the full-scale input range of the device. Decouple the AVDD and DVDD pins individually with 1- $\mu$ F ceramic decoupling capacitors, as shown in [Figure 44](#).



**Figure 44. Power-Supply Decoupling**

### 10.2 Estimating Digital Power Consumption

The current consumption from the DVDD supply depends on the DVDD voltage, load capacitance on the SDO line, and the output code. The load capacitance on the SDO line is charged by the current from the SDO pin on every rising edge of the data output and is discharged on every falling edge of the data output. The current consumed by the device from the DVDD supply can be calculated by [Equation 4](#):

$$I_{DVDD} = C \times V \times f$$

where:

- C = Load capacitance on the SDO line,
- V = DVDD supply voltage, and
- f = Number of transitions on the SDO output.

(4)

The number of transitions on the SDO output depends on the output code, and thus changes with the analog input. The maximum value of f occurs when data output on the SDO change on every SCLK. SDO changing on every SCLK results in an output code of AAAh or 555h. For an output code of AAAh or 555h at a 1-MSPS throughput, the frequency of transitions on the SDO output is 6 MHz.

To keep the current consumption at the lowest possible value, the DVDD supply must be kept at the lowest permissible value and the capacitance on the SDO line must be kept as low as possible.

### 10.3 Optimizing Power Consumed by the Device

- Keep the analog supply voltage (AVDD) as per the analog input full-scale range (FSR) requirement.
- Keep the digital supply voltage (DVDD) at the lowest permissible value.
- Reduce the load capacitance on the SDO output.
- Run the device at optimum throughput. Power consumption reduces with throughput.

## 11 Layout

### 11.1 Layout Guidelines

Figure 45 shows a board layout example for the ADS7043. Use a ground plane underneath the device and partition the PCB into analog and digital sections. Avoid crossing digital lines with the analog signal path and keep the analog input signals and the reference input signals away from noise sources. In Figure 45, the analog input and reference signals are routed on the top and left side of the device while the digital connections are routed on the bottom and right side of the device.

The power sources to the device must be clean and well-bypassed. Use 1- $\mu$ F ceramic bypass capacitors in close proximity to the analog (AVDD) and digital (DVDD) power-supply pins. Avoid placing vias between the AVDD and DVDD pins and the bypass capacitors. Connect all ground pins to the ground plane using short, low-impedance paths. The AVDD supply voltage for the ADS7043 also functions as a reference for the device. Place the decoupling capacitor ( $C_{REF}$ ) for AVDD close to the device AVDD and GND pins.  $C_{REF}$  must be connected to the device pins with thick copper tracks, as shown in Figure 45.

The fly-wheel RC filters are placed close to the device. Among ceramic surface-mount capacitors, COG (NPO) ceramic capacitors provide the best capacitance precision. The type of dielectric used in COG (NPO) ceramic capacitors provides the most stable electrical properties over voltage, frequency, and temperature changes.

### 11.2 Layout Example

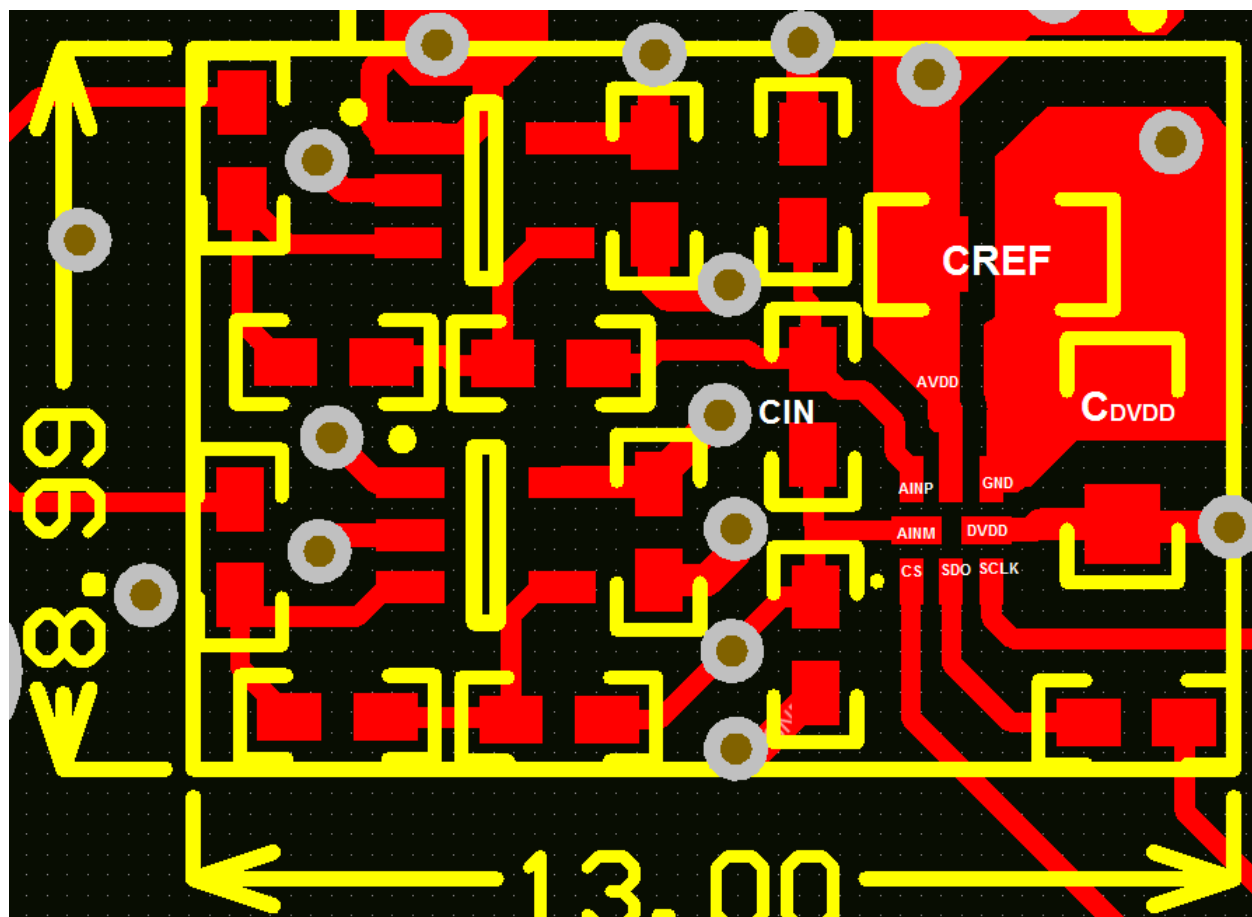

Figure 45. Example Layout

## 12 Device and Documentation Support

### 12.1 Documentation Support

#### 12.1.1 Related Documentation

For related documentation see the following:

- OPA316 Data Sheet, [SBOS703](#)
- OPA835 Data Sheet, [SLOS713](#)
- THS4531A Data Sheet, [SLOS823](#)
- TPS79101 Data Sheet, [SLVS325](#)
- *Analysis of fully differential amplifiers*, [SLYT157](#)

### 12.2 Trademarks

TINA is a trademark of Texas Instruments, Inc.

SPI is a trademark of Motorola.

All other trademarks are the property of their respective owners.

### 12.3 Electrostatic Discharge Caution



This integrated circuit can be damaged by ESD. Texas Instruments recommends that all integrated circuits be handled with appropriate precautions. Failure to observe proper handling and installation procedures can cause damage.

ESD damage can range from subtle performance degradation to complete device failure. Precision integrated circuits may be more susceptible to damage because very small parametric changes could cause the device not to meet its published specifications.

### 12.4 Glossary

[SLYZ022](#) — *TI Glossary*.

This glossary lists and explains terms, acronyms, and definitions.

## 13 Mechanical, Packaging, and Orderable Information

The following pages include mechanical packaging and orderable information. This information is the most current data available for the designated devices. This data is subject to change without notice and revision of this document. For browser-based versions of this data sheet, refer to the left-hand navigation.

**PACKAGING INFORMATION**

Orderable Device	Status (1)	Package Type	Package Drawing	Pins	Package Qty	Eco Plan (2)	Lead/Ball Finish (6)	MSL Peak Temp (3)	Op Temp (°C)	Device Marking (4/5)	Samples
ADS7043IDCUR	ACTIVE	US8	DCU	8	3000	Green (RoHS & no Sb/Br)	CU NIPDAU	Level-1-260C-UNLIM	-40 to 125	7043	<a href="#">Samples</a>
ADS7043IDCUT	ACTIVE	US8	DCU	8	250	Green (RoHS & no Sb/Br)	CU NIPDAU	Level-1-260C-UNLIM	-40 to 125	7043	<a href="#">Samples</a>
ADS7043IRUGR	ACTIVE	X2QFN	RUG	8	3000	Green (RoHS & no Sb/Br)	CU NIPDAUAG	Level-1-260C-UNLIM	-40 to 125	FW	<a href="#">Samples</a>

(1) The marketing status values are defined as follows:

**ACTIVE:** Product device recommended for new designs.

**LIFEBUY:** TI has announced that the device will be discontinued, and a lifetime-buy period is in effect.

**NRND:** Not recommended for new designs. Device is in production to support existing customers, but TI does not recommend using this part in a new design.

**PREVIEW:** Device has been announced but is not in production. Samples may or may not be available.

**OBSOLETE:** TI has discontinued the production of the device.

(2) Eco Plan - The planned eco-friendly classification: Pb-Free (RoHS), Pb-Free (RoHS Exempt), or Green (RoHS & no Sb/Br) - please check <http://www.ti.com/productcontent> for the latest availability information and additional product content details.

**TBD:** The Pb-Free/Green conversion plan has not been defined.

**Pb-Free (RoHS):** TI's terms "Lead-Free" or "Pb-Free" mean semiconductor products that are compatible with the current RoHS requirements for all 6 substances, including the requirement that lead not exceed 0.1% by weight in homogeneous materials. Where designed to be soldered at high temperatures, TI Pb-Free products are suitable for use in specified lead-free processes.

**Pb-Free (RoHS Exempt):** This component has a RoHS exemption for either 1) lead-based flip-chip solder bumps used between the die and package, or 2) lead-based die adhesive used between the die and leadframe. The component is otherwise considered Pb-Free (RoHS compatible) as defined above.

**Green (RoHS & no Sb/Br):** TI defines "Green" to mean Pb-Free (RoHS compatible), and free of Bromine (Br) and Antimony (Sb) based flame retardants (Br or Sb do not exceed 0.1% by weight in homogeneous material)

(3) MSL, Peak Temp. - The Moisture Sensitivity Level rating according to the JEDEC industry standard classifications, and peak solder temperature.

(4) There may be additional marking, which relates to the logo, the lot trace code information, or the environmental category on the device.

(5) Multiple Device Markings will be inside parentheses. Only one Device Marking contained in parentheses and separated by a "~" will appear on a device. If a line is indented then it is a continuation of the previous line and the two combined represent the entire Device Marking for that device.

(6) Lead/Ball Finish - Orderable Devices may have multiple material finish options. Finish options are separated by a vertical ruled line. Lead/Ball Finish values may wrap to two lines if the finish value exceeds the maximum column width.

**Important Information and Disclaimer:** The information provided on this page represents TI's knowledge and belief as of the date that it is provided. TI bases its knowledge and belief on information provided by third parties, and makes no representation or warranty as to the accuracy of such information. Efforts are underway to better integrate information from third parties. TI has taken and

continues to take reasonable steps to provide representative and accurate information but may not have conducted destructive testing or chemical analysis on incoming materials and chemicals. TI and TI suppliers consider certain information to be proprietary, and thus CAS numbers and other limited information may not be available for release.

In no event shall TI's liability arising out of such information exceed the total purchase price of the TI part(s) at issue in this document sold by TI to Customer on an annual basis.



DCU (S-PDSO-G8)

PLASTIC SMALL OUTLINE PACKAGE (DIE DOWN)

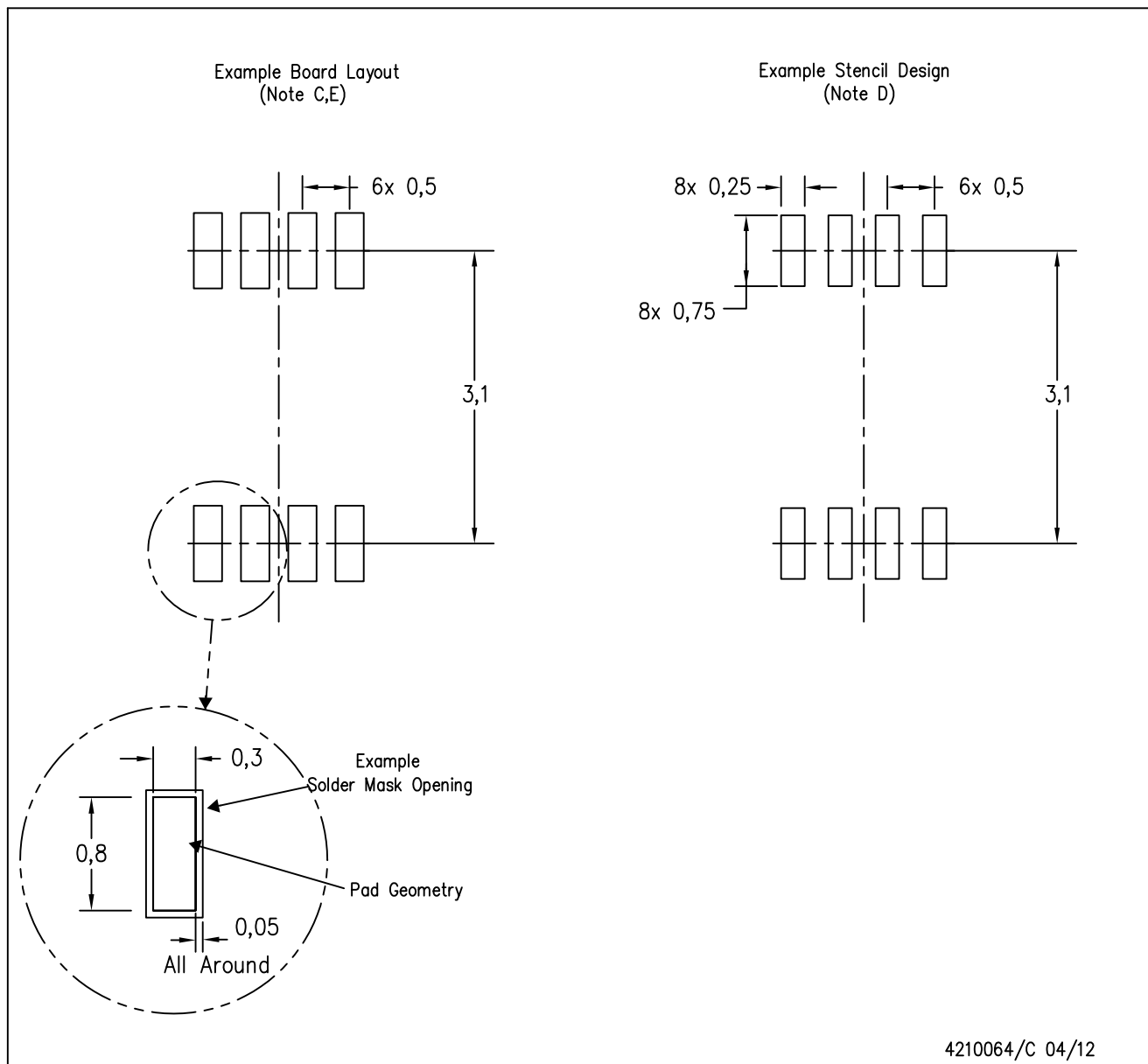

- NOTES:
- A. All linear dimensions are in millimeters.
  - B. This drawing is subject to change without notice.
  - C. Publication IPC-7351 is recommended for alternate designs.
  - D. Laser cutting apertures with trapezoidal walls and also rounding corners will offer better paste release. Customers should contact their board assembly site for stencil design recommendations. Refer to IPC-7525 for other stencil recommendations.
  - E. Customers should contact their board fabrication site for solder mask tolerances between and around signal pads.



RUG (R-PQFP-N8)

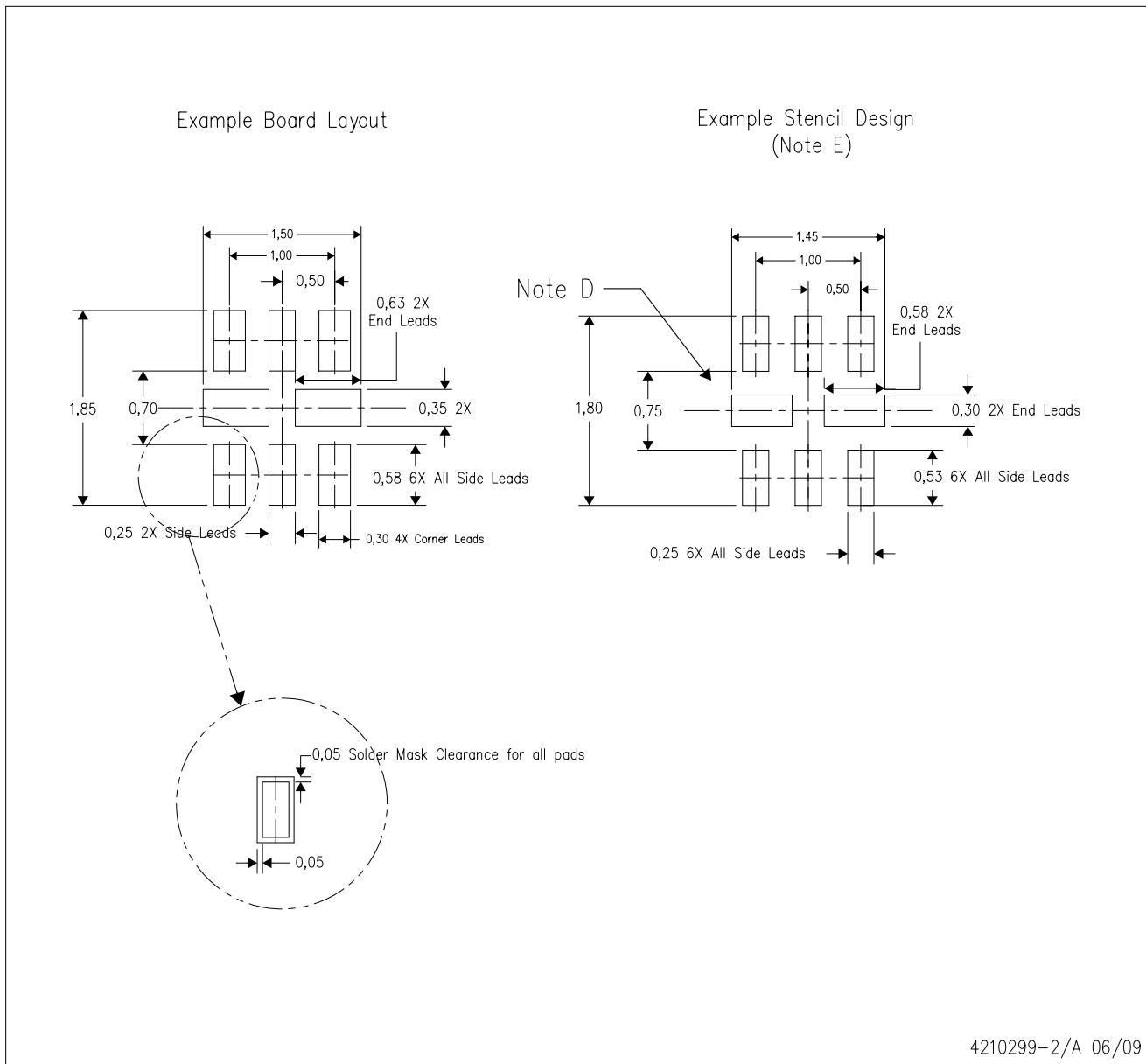

4210299-2/A 06/09

- NOTES:
- A. All linear dimensions are in millimeters.
  - B. This drawing is subject to change without notice.
  - C. Publication IPC-7351 is recommended for alternate designs.
  - D. Customers should contact their board fabrication site for minimum solder mask web tolerances between signal pads.
  - E. Maximum stencil thickness 0,127 mm (5 mils). All linear dimensions are in millimeters.
  - F. Laser cutting apertures with trapezoidal walls and also rounding corners will offer better paste release. Customers should contact their board assembly site for stencil design recommendations. Refer to IPC 7525 for stencil design considerations.
  - G. Side aperture dimensions over-print land for acceptable area ratio > 0.66. Customer may reduce side aperture dimensions if stencil manufacturing process allows for sufficient release at smaller opening.

## IMPORTANT NOTICE

Texas Instruments Incorporated and its subsidiaries (TI) reserve the right to make corrections, enhancements, improvements and other changes to its semiconductor products and services per JESD46, latest issue, and to discontinue any product or service per JESD48, latest issue. Buyers should obtain the latest relevant information before placing orders and should verify that such information is current and complete. All semiconductor products (also referred to herein as "components") are sold subject to TI's terms and conditions of sale supplied at the time of order acknowledgment.

TI warrants performance of its components to the specifications applicable at the time of sale, in accordance with the warranty in TI's terms and conditions of sale of semiconductor products. Testing and other quality control techniques are used to the extent TI deems necessary to support this warranty. Except where mandated by applicable law, testing of all parameters of each component is not necessarily performed.

TI assumes no liability for applications assistance or the design of Buyers' products. Buyers are responsible for their products and applications using TI components. To minimize the risks associated with Buyers' products and applications, Buyers should provide adequate design and operating safeguards.

TI does not warrant or represent that any license, either express or implied, is granted under any patent right, copyright, mask work right, or other intellectual property right relating to any combination, machine, or process in which TI components or services are used. Information published by TI regarding third-party products or services does not constitute a license to use such products or services or a warranty or endorsement thereof. Use of such information may require a license from a third party under the patents or other intellectual property of the third party, or a license from TI under the patents or other intellectual property of TI.

Reproduction of significant portions of TI information in TI data books or data sheets is permissible only if reproduction is without alteration and is accompanied by all associated warranties, conditions, limitations, and notices. TI is not responsible or liable for such altered documentation. Information of third parties may be subject to additional restrictions.

Resale of TI components or services with statements different from or beyond the parameters stated by TI for that component or service voids all express and any implied warranties for the associated TI component or service and is an unfair and deceptive business practice. TI is not responsible or liable for any such statements.

Buyer acknowledges and agrees that it is solely responsible for compliance with all legal, regulatory and safety-related requirements concerning its products, and any use of TI components in its applications, notwithstanding any applications-related information or support that may be provided by TI. Buyer represents and agrees that it has all the necessary expertise to create and implement safeguards which anticipate dangerous consequences of failures, monitor failures and their consequences, lessen the likelihood of failures that might cause harm and take appropriate remedial actions. Buyer will fully indemnify TI and its representatives against any damages arising out of the use of any TI components in safety-critical applications.

In some cases, TI components may be promoted specifically to facilitate safety-related applications. With such components, TI's goal is to help enable customers to design and create their own end-product solutions that meet applicable functional safety standards and requirements. Nonetheless, such components are subject to these terms.

No TI components are authorized for use in FDA Class III (or similar life-critical medical equipment) unless authorized officers of the parties have executed a special agreement specifically governing such use.

Only those TI components which TI has specifically designated as military grade or "enhanced plastic" are designed and intended for use in military/aerospace applications or environments. Buyer acknowledges and agrees that any military or aerospace use of TI components which have **not** been so designated is solely at the Buyer's risk, and that Buyer is solely responsible for compliance with all legal and regulatory requirements in connection with such use.

TI has specifically designated certain components as meeting ISO/TS16949 requirements, mainly for automotive use. In any case of use of non-designated products, TI will not be responsible for any failure to meet ISO/TS16949.

### Products

Audio	<a href="http://www.ti.com/audio">www.ti.com/audio</a>
Amplifiers	<a href="http://amplifier.ti.com">amplifier.ti.com</a>
Data Converters	<a href="http://dataconverter.ti.com">dataconverter.ti.com</a>
DLP® Products	<a href="http://www.dlp.com">www.dlp.com</a>
DSP	<a href="http://dsp.ti.com">dsp.ti.com</a>
Clocks and Timers	<a href="http://www.ti.com/clocks">www.ti.com/clocks</a>
Interface	<a href="http://interface.ti.com">interface.ti.com</a>
Logic	<a href="http://logic.ti.com">logic.ti.com</a>
Power Mgmt	<a href="http://power.ti.com">power.ti.com</a>
Microcontrollers	<a href="http://microcontroller.ti.com">microcontroller.ti.com</a>
RFID	<a href="http://www.ti-rfid.com">www.ti-rfid.com</a>
OMAP Applications Processors	<a href="http://www.ti.com/omap">www.ti.com/omap</a>
Wireless Connectivity	<a href="http://www.ti.com/wirelessconnectivity">www.ti.com/wirelessconnectivity</a>

### Applications

Automotive and Transportation	<a href="http://www.ti.com/automotive">www.ti.com/automotive</a>
Communications and Telecom	<a href="http://www.ti.com/communications">www.ti.com/communications</a>
Computers and Peripherals	<a href="http://www.ti.com/computers">www.ti.com/computers</a>
Consumer Electronics	<a href="http://www.ti.com/consumer-apps">www.ti.com/consumer-apps</a>
Energy and Lighting	<a href="http://www.ti.com/energy">www.ti.com/energy</a>
Industrial	<a href="http://www.ti.com/industrial">www.ti.com/industrial</a>
Medical	<a href="http://www.ti.com/medical">www.ti.com/medical</a>
Security	<a href="http://www.ti.com/security">www.ti.com/security</a>
Space, Avionics and Defense	<a href="http://www.ti.com/space-avionics-defense">www.ti.com/space-avionics-defense</a>
Video and Imaging	<a href="http://www.ti.com/video">www.ti.com/video</a>

### TI E2E Community

[e2e.ti.com](http://e2e.ti.com)