

# CGA5L3X7R1H225K160AE

TDK Item Description : CGA5L3X7R1H225KT\*\*S



Equivalent C3216X7R1H225K for Automotive

## Application & Main Feature

Automotive Grade ( Soft Termination )

## Series

CGA5(3216) [EIA CC1206]

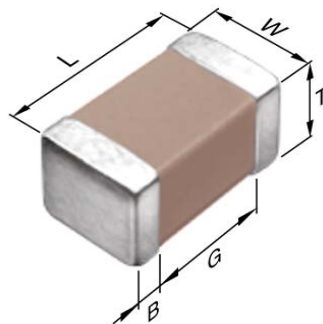

## Dimensions

L 3.20mm +0.4,-0.2mm  
 W 1.60mm +0.3,-0.2mm  
 T 1.60mm +0.3,-0.2mm  
 B 0.20mm Min.  
 G 1.00mm Min.

## Temperature Characteristic

X7R (-55 to 125 degC +/-15%)

## Rated Voltage

1H (50Vdc)

## Capacitance

2.2uF

## Capacitance Tolerance

K (+/-10%)

## Dissipation Factor

5% Max.

## Insulation Resistance

227Mohm Min.

## AEC-Q200

Yes

## DC Bias Characteristic

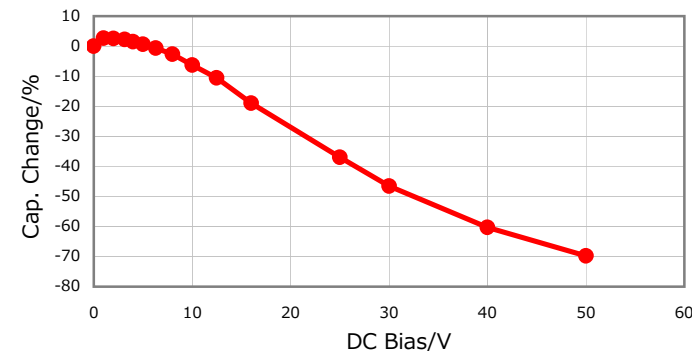

## |Z|, ESR vs. Freq. Characteristics

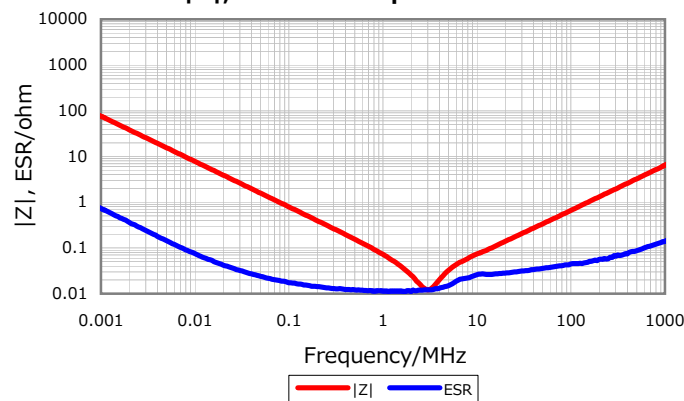

## Temperature Characteristics

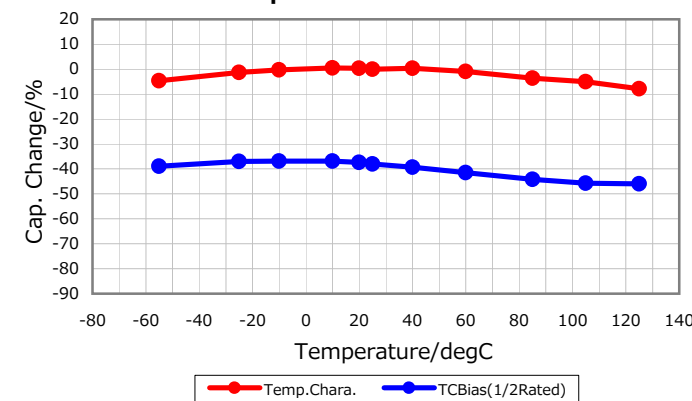

## Cap. vs. Freq. Characteristic

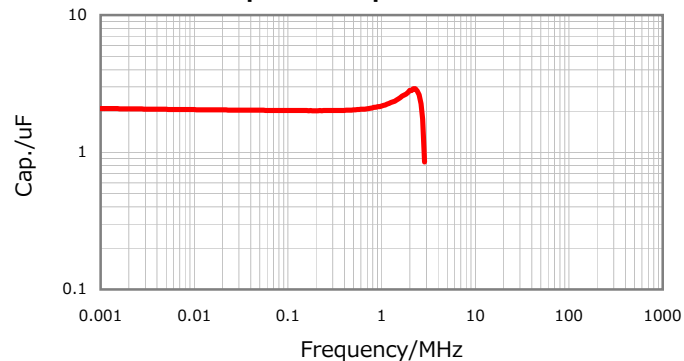

## Ripple Temperature Rise Characteristics

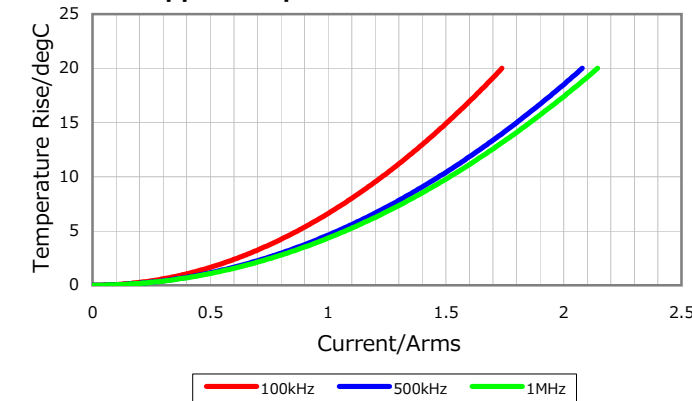

Characterization Sheet ( Multilayer Ceramic Chip Capacitors )



All specifications are subject to change without notice.

January 4, 2016