

FCX – AX SERIES ABSOLUTE PRESSURE TRANSMITTER

DATA SHEET

FHA, FKA...3

The FCX–AX absolute pressure transmitter accurately measures absolute pressure and transmits a proportional 4 to 20mA signal.

The transmitter utilizes a unique micromachined capacitance silicon sensor with state-of-the-art microprocessor technology to provide exceptional performance and functionality.

FEATURES

1. High accuracy

0.2% accuracy for all calibrated spans is a standard feature for all AP models covering 1.6kPa{0.016bar} range to 3000kPa{30bar} high pressure range. 0.1% accuracy is available as option. Fuji's micro-capacitance silicon sensor assures this accuracy for all suppressed calibration ranges without additional adjustment.

2. Minimum environmental influence

The "Advanced Floating Cell" design which protects the pressure sensor against changes in temperature, and overpressure substantially reduces total measurement error in actual field applications.

3. Replaceable Communication Module

Fuji micro-electronics manufacturing technology offers replaceable communication module that makes FCX–AX transmitter very unique in design. In case of change in communication protocol, all that needs to be done is just to replace the module and the transmitter gets upgraded to the new version.

4. Fuji/HART bilingual communication module

The communication module is "bilingual" to speak both Fuji proprietary protocol and HART. Any HART compatible devices can communicate with FCX–AX series transmitters.

5. Application flexibility

Various options that render the FCX–AX suitable for almost any process applications include:

- Analog indicator at either the electronics side or terminal side
- Full range of hazardous area approvals
- Built-in RFI filter and lightning arrester
- 4½ -digits LCD meter
- Stainless steel electronics housing
- Wide selection of materials

6. Burnout current flexibility (Under Scale: 3.2 to 3.8mA, Over Scale: 20.8 to 21.6mA)

Burnout signal level is adjustable using Model FXW hand Held Communicator (HHC) to comply with NAMUR NE43. (Available for amplifier unit from version 24 and FXW(HHC) version 5.3.)

7. Dry calibration without reference pressure

Thanks to the best combination of unique construction of mechanical parts (Sensor unit) and high performance electronics circuit (Electronics unit), reliability of dry calibration without reference pressure is at equal level as wet calibration.



SPECIFICATIONS

Functional specifications

Type:

Model FHA: 4 to 20mA

Model FKA: 4 to 20mA with digital signal

Service:

Liquid, gas, or vapour

Span, range, and overrange limit:

Type	Span limit [kPa abs] [bar abs]			Range limit [kPa abs] [bar abs]	Overrange limit [MPa] [bar]
	Min.		Max.		
	FHA	FKA	FHA/FKA		
F□A□01	1.6 {0.016}	1.6 {0.016}	16 {0.16}	0 to +16 {0 to +0.16}	0.5 {5}
F□A□02	13 {0.13}	1.6 {0.016}	130 {1.3}	0 to +130 {0 to +1.3}	0.5 {5}
F□A□03	50 {0.5}	5 {0.05}	500 {5}	0 to +500 {0 to +5}	1.5 {15}
F□A□04	300 {3}	30 {0.3}	3000 {30}	0 to +3000 {0 to +30}	9 {90}

Remark: To minimize environmental influence, span should be greater than 1/40 of the max. span in most applications.

- The maximum span of each sensor can be converted to different units using factors as below.

$$1\text{MPa abs} = 10^3\text{kPa abs} = 10\text{bar abs} = 10.19716\text{kgf/cm}^2\text{ abs} = 145.0377\text{psi abs}$$

$$1\text{kPa abs} = 10\text{mbar abs} = 101.9716\text{mmH}_2\text{O abs} = 4.01463\text{inH}_2\text{O abs} = 7.50062\text{mmHg abs}$$

Output signal:

Model FHA: 4 to 20mA DC 2-wire

Model FKA: 4 to 20mA DC with digital signal superimposed on the 4 to 20mA signal.

Power supply:

Transmitter operates on 10.5V to 45V DC at transmitter terminals.

10.5V to 32V DC for the units with optional arrester.

Load limitations: see figure below

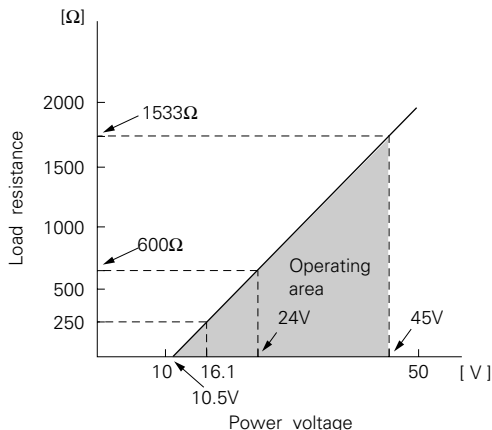

Note: For communication with HHC (Model: FXW), min. of 250Ω is required.

Hazardous locations: (Approval pending)

Authorities	Flameproof	Intrinsic safety	Type N Nonincendive
BASEEFA Factory Mutual	Ex ds IIC T5, T6 Class I II III Div. 1	EEx ia IIC T4, T5 Class I II III Div. 1	Ex N II T5 Class I II III Div. 2
CSA	Groups B thru. G Class I II III Div. 1	Groups A thru. F Class I II III Div. 1	Groups A thru. G Class I II III Div. 2
RIIS SAA	Groups C thru. G Ex ds IIB+H ₂ T4 Ex d II C T5, T6 IP 66/67	Groups A thru. G — — IP 66/67	Groups A thru. G — — Ex n II C T5, T6 IP 66/67

Zero/span adjustment:

Model FHA: Zero is adjustable from the external adjustment screw.

The adjustment screw can also function to adjust span when MODE SWITCH (located on the electronics unit) is in the span mode. INHIBIT mode to disable the adjustment screw is also available.

Model FKA: Zero and span are adjustable from the HHC. Zero is also adjustable externally from the adjustment screw.

Damping: Adjustable electrical damping

Model FHA: The time constant is adjustable to 0, 0.3, 1.2, 4.8, or 19.2 seconds.

Model FKA: The time constant is adjustable between 0 to 38.4 seconds. (9 steps)

Zero elevation/suppression:

Zero can be elevated within the specified range limit of each sensor model.

Normal/reverse action:

Model FHA: Selectable by moving a jumper pin located on the electronics unit.

Model FKA: Configurable from HHC.

Indication: Analog indicator or 4 1/2 -digit LCD meter, as specified.

Burnout direction: If self-diagnostic detect transmitter failure, the analog signal will be driven to either "Output Hold", "Output Overscale" or "Output Underscale" modes.

Model FHA: Unless otherwise specified in the order, the transmitter will be shipped in "Output Hold" mode. (Output signal just before failure happens is maintained.)

Model FKA: Selectable from HHC

"Output Hold":

Output signal is hold as the value just before failure happens.

"Output Overscale":

Approx. 21.6mA
(Adjustable within the range 20.8mA to 21.6mA from HHC)

"Output Underscale":

Approx. 3.8mA
(Adjustable within the range 3.2mA to 3.8mA from HHC)

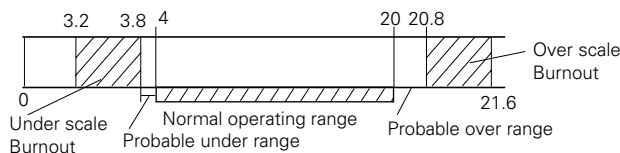

Loop-check output:

Model FHA: Transmitter can output constant signal of 4mA, 12mA, or 20mA if MODE SWITCH is set to the loop check mode.

Model FKA: Transmitter can be configured to provide constant signal 3.8mA through 21.6mA by HHC.

Temperature limit: Ambient: -40 to +85°C

(-20 to +80°C for LCD indicator)
(-40 to +60°C for arrester option)

For explosionproof units (flameproof or intrinsic safety), ambient temperature must be within the limits specified by each standard.

Process: -40 to +85°C for silicone fill sensor

Storage: -40 to +90°C

Humidity limit: 0 to 100% RH

Communication: (Model FKA only)

With HHC (Model FXW, consult Data Sheet No. EDS8-47), following information can be remotely displayed or reconfigured.

Items	Display	Set
Tag No.	✓	✓
Model No.	✓	✓
Serial No.	✓	—
Engineering unit	✓	✓
Range limit	✓	—
Measuring range	✓	✓
Damping	✓	✓
Output mode	✓	✓
Burnout direction	✓	✓
Adjustment	✓	✓
Output adjust	—	✓
Data	✓	—
Self diagnoses	✓	—
Printer	—	—
External switch lock	✓	✓
Transmitter display(*)	✓	✓

Note: (*) HHC's version must be more than 5.0 (or FXW □□□□1-□□), to use this function.

Performance specifications

Accuracy rating: (including linearity, hysteresis, and repeatability).

(Standard)

For spans greater than 1/10 of URL: ±0.2% of span

For spans below 1/10 of URL (Model FKA only):

$$\pm (0.1 + 0.1 \frac{0.1 \times \text{URL}}{\text{Span}}) \% \text{ of span}$$

(Option)

(Not available for Max span 16kPa abs, 130kPa abs)

For spans greater than 1/10 of URL: ±0.1% of span

For spans below 1/10 of URL (Model FKA only):

$$\pm (0.05 + 0.05 \frac{0.1 \times \text{URL}}{\text{Span}}) \% \text{ of span}$$

Linearity: 0.1% of calibrated span

Stability: ±0.2% of upper range limit (URL) for 24 months

Temperature effect:

Effect per 28°C change between the limits of -40°C and +85°C

$$\text{Zero shift: } \pm(0.125 + 0.1 \frac{\text{URL}}{\text{Span}}) \%$$

$$\text{Total effect: } \pm(0.15 + 0.1 \frac{\text{URL}}{\text{Span}}) \%$$

Double the effects for material code (7th digit in code symbols) "H", "M", and "T".

Overrange effect: Zero shift; 0.2% of URL for any overrange to maximum limit

Supply voltage effect:

Less than 0.05% of calibrated span per 10V

RFI effect:

Less than 0.2% of URL for the frequencies of 20 to 1000MHz and field strength 30V/m when electronics covers on. (Classification: 2-abc: 0.2% span per SAMA PMC 33.1)

Step response:

Time constant: 0.2 s
Dead time: approximately 0.3 s (without electrical damping)

Mounting position effect:

Zero shift, less than 0.1kPa(1mbar) for a 10° tilt in any plane.

No effect on span. This error can be corrected by adjusting zero.

Dielectric strength:

500V AC, 50/60Hz 1 min., between circuit and earth.

Insulation resistance:

More than 100MΩ at 500V DC.

Turn-on time: 4 sec

Internal resistance for external field indicator:

12Ω or less

Physical specifications

Electrical connections:

G1/2, 1/2-14NPT, Pg13.5, or M20 x 1.5 conduit, as specified.

Process connections:

1/4-18 NPT or Rc1/4, as specified.

Process-wetted parts material:

Material code (7th digit in "Code symbols")	Process cover	Diaphragm	Wetted sensor body	Vent/drain
V	316 stainless steel	316L stainless steel	316 stainless steel	316 stainless steel
H	316 stainless steel	Hastelloy-C	Hastelloy-C lining	316 stainless steel
M	316 stainless steel	Monel	Monel lining	316 stainless steel
T	316 stainless steel	Tantalum	Tantalum lining	316 stainless steel

Notes: Sensor O-rings: Viton

Availability of above material design depends on ranges.

Refer to "Code symbols".

Non-wetted parts material:

Electronics housing: Low copper die-cast aluminum alloy (standard), finished with polyester coating, or 316 stainless steel (SCS14 per JIS G5121), as specified.

Bolts and nut: Cr-Mo alloy (standard) or 304 stainless steel

Fill fluid: Silicone oil

Mounting bracket: Carbon steel with epoxy coating or 304 stainless steel, as specified

Environmental protection:

IEC IP67 and NEMA 4X

Mounting:

On 60.5mm (JIS 50A) pipe using mounting bracket, direct wall mounting, or direct process mounting.

Mass{weight}:

Transmitter approximately 3.4kg without options.

Add; 0.5kg for mounting bracket

0.8kg for indicator option

4.5kg for stainless steel housing option

Optional features

Indicator:

A plug-in analog indicator (1.5% accuracy) can be housed in the electronics compartment or in the terminal box of the housing. An optional 4½ digits LCD meter is also available.

Arrester:

A built-in arrester protects the electronics from lightning surges.

Lightning surge immunity:

4KV (1.2 x 50µs)

Degreasing:

Process-wetted parts are cleaned, but the fill fluid is standard silicone oil. Not for use on oxygen or chlorine measurement.

NACE specification:

Metallic materials for all pressure boundary parts comply with NACE MR-01-75. 304 stainless steel bolts and nuts, ASTM B7M or L7M bolts and 2HM nuts (Class II) are available.

Customer tag:

A stainless steel tag for customer tag data is wired to the transmitter.

Coating of cell:

Cell's surface is finished with epoxy/polyurethane double coating. Specify if environment is extremely corrosive.

ACCESSORIES

Oval flanges:

(Model FFP, refer to Data Sheet No. EDS6-10)

Converts process connection to 1/2-14 NPT or to Rc1/2; in carbon steel or in 316 stainless steel.

Hand held communicator:

(Model FXW, refer to Data Sheet No.EDS 8-47)

Communication module: (Standard for model FKA)

By adding communication module, remote setting function becomes available for FHA.

Remark: When the communication module is connected, the operation mode of external zero/span adjustment screw is limited to zero adjustment only.

CODE SYMBOLS

1	2	3	4	5	6	7	8	9	10	11	12	13	14	15	Description			
			0												Type			
FHA															4 to 20mA, Output type			
FKA															4 to 20mA with digital signal, Output type			
															Connections			
															Process connection	Oval flange screw	Conduit connection	
S															Rc1/4	7/16-20UNF	G 1/2	
T															1/4-18NPT	7/16-20UNF	1/2-14NPT	
V															1/4-18NPT	M10	Pg 13.5	
W															1/4-18NPT	M10	M20 × 1.5	
X															1/4-18NPT	7/16-20UNF	Pg 13.5	
															Span limit			
															Span limit FHA/FKA [kPa abs]{bar abs}{*}	Process cover	Diaphragm	Wetted cell body
1V															1.6/1.6...16/16	316 stainless steel	316L stainless steel	316 stainless steel
1H															{0.016/0.016...0.16/0.16	316 stainless steel	Hast. C	Hast. C lining
1M																316 stainless steel	Monel	Monel lining
2V															13/1.6...130/130	316 stainless steel	316L stainless steel	316 stainless steel
2H															{0.13/0.016...1.3/1.3}	316 stainless steel	Hast. C	Hast. C lining
2M																316 stainless steel	Monel	Monel lining
2T																316 stainless steel	Tantalum	Tantalum lining
3V															50/5...500/500	316 stainless steel	316L stainless steel	316 stainless steel
3H															{0.5/0.05...5/5}	316 stainless steel	Hast. C	Hast. C lining
3M																316 stainless steel	Monel	Monel lining
3T																316 stainless steel	Tantalum	Tantalum lining
4V															300/30...3000/3000	316 stainless steel	316L stainless steel	316 stainless steel
4H															{3/0.3...30/30}	316 stainless steel	Hast. C	Hast. C lining
4M																316 stainless steel	Monel	Monel lining
4T																316 stainless steel	Tantalum	Tantalum lining

Note: * 100: 1 turn down is possible for model FKA, but should be used at a span greater than 1/40 of the maximum span for better performance.

The product conforms to the requirements of the Electromagnetic compatibility Directive 89/336/EEC as detailed within the technical construction file number TN510412. The applicable standards used to demonstrate compliance are :-

EMI (Emission) EN50081-1 : 1992

Test item	Frequency range	Basic standard
Applicable Electro-magnetic Radiation Disturbance	30-1000MHz	EN55022 Class B

EMS (Immunity) EN50082-1 : 1992

No.	Test item	Test specification	Basic standard	Performance criteria
1	Electrostatic discharge	8kV (Air)	IEC 801-2:1984	B
2	Radio-frequency electromagnetic field.	27-500MHz 3V/m (Unmodulated)	IEC 801-3:1984	A
3	Fast transients common mode	0.5kV, 5/50 (Tr/Th) ns 5kHz Rep.	IEC 801-4:1988	B

"LVD - The transmitter is not covered by the requirements of the LVD standard."

1	2	3	4	5	6	7	8	9	10	11	12	13	14	15
F	H	A	0				3							
F	K	A	0				3							

		Description		
Indicator and arrester				
	Indicator			Arrester
A	None			None
B	Analog, 0 to 100% linear scale			None
D	Analog, custom scale			None
J	Analog, double scale			None (JIS and SI unit)
E	None			Yes
F	Analog, 0 to 100% linear scale			Yes
H	Analog, custom scale			Yes
K	Analog, double scale			Yes (JIS and SI unit)
L	Digital, 0 to 100%			None
P	Digital, custom scale			None (Model FKA only)
Q	Digital, 0 to 100%			Yes
S	Digital, custom scale			Yes (Model FKA only)
Approvals for hazardous locations (Approval pending)				
A	None (for ordinary locations)			
B	JIS, Flameproof (Conduit seal)			(Available for 4th digit code "S")
C	JIS, Flameproof (Cable gland seal)			(Available for 4th digit code "S")
D	FM, Flameproof (or explosionproof)			(Available for 4th digit code "T")
E	CSA, Flameproof (or explosionproof)			(Available for 4th digit code "T")
M	BASEEFA, Flameproof (Conduit seal)			
N	BASEEFA, Flameproof (Cable gland seal) (Conduit connection G 1/2 only)			
H	FM, Intrinsic safety and nonincendive			
J	CSA, Intrinsic safety and nonincendive			
K	CENELEC, Intrinsic safety			
P	CENELEC, Intrinsic safety and BASEEFA, Type N			
R	SAA Flameproof (Conduit seal)(Available for 4th digit code "S,T,W)			
T	SAA Intrinsic safety(Available for 4th digit code "S,T,W)			
Q	SAA Type- N(non-sparking)(Available for 4th digit code "S,T,W)			
Side vent/ drain and mounting bracket				
	Side vent/drain			Mounting bracket
A	None			None
B	None			Yes, carbon steel
C	None			Yes, stainless steel
D	Yes			None
E	Yes			Yes, carbon steel
F	Yes			Yes, stainless steel
Stainless steel parts				
	Stainless steel tag plate	Stainless steel elec. housing		Coating of cell
Y	None	None		None
B	Yes	None		None
C	None	Yes		None
E	Yes	Yes		None
M	None	None		Yes
N	Yes	None		Yes
P	None	Yes		Yes
Q	Yes	Yes		Yes
Special applications and fill fluid				
	Treatment			Fill fluid
Y	None (standard)			Silicone oil
G	Degreasing			Silicone oil
N	NACE specification			Silicone oil (7th digit code "T" and 15th digit code "A", "B" are not available)
Sensor O-ring				
A	Viton			
Bolt/nut				
A	Cr-Mo alloy hexagon socket head cap screw/carbon steel nut			
B	Cr-Mo alloy hexagon bolt/nut			
C	NACE bolt/nut (ASTM A193 B7M/A194 2HM)			
D	NACE bolt/nut (ASTM A320 L7M/A194 2HM)			
E	304 stainless steel/304 stainless steel (*1)			

* (1) In case of tropical use, select stainless bolts and nuts.

OUTLINE DIAGRAM (Unit:mm)

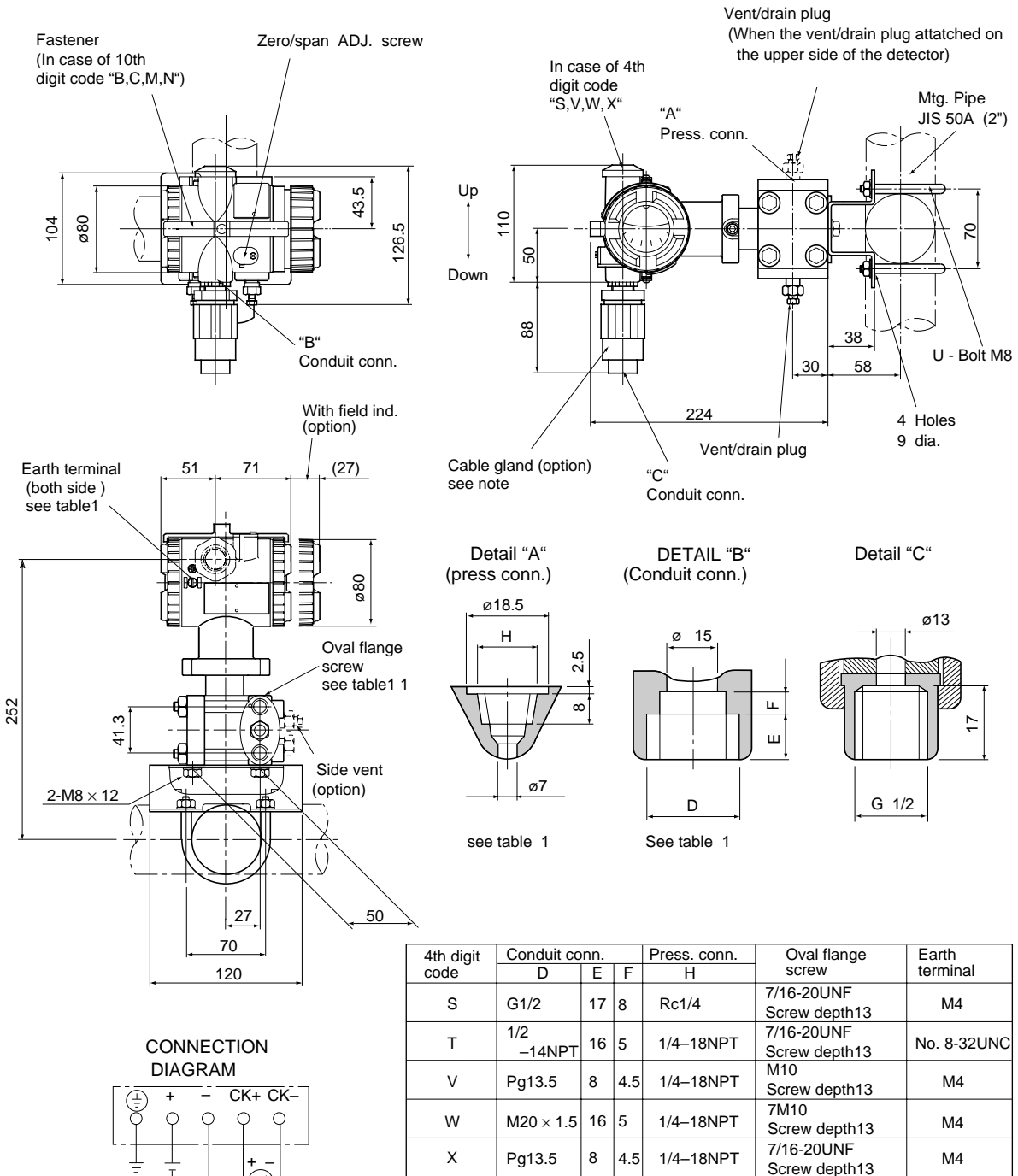

Note1) : Cable gland is supplied in case of flamproof packing type.
ø11 cable is suitable.

Table 1

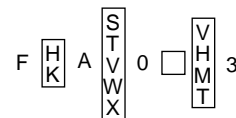

Fuji Electric Co.,Ltd.

Head office

11-2 Osaki 1-chome, Shinagawa-ku, Tokyo, 141-0032 Japan
Phone: 81-3-5435-7111
<http://www.fujielectric.co.jp/eng/sg/KEISOKU/welcome.htm>

Fuji Electric Instruments Co.,Ltd.

Sales Div.

International Sales Dept.

No.1, Fuji-machi, Hino-city, Tokyo, 191-8502 Japan
Phone: 81-42-585-6201, 6202
Fax: 81-42-585-6187, 6189