

### 1.0A SUPERFAST GLASS PASSVITED RECTIFIER

#### Features

- Glass Passivated Die Construction
- Low Forward Voltage Drop
- High Current Capability
- High Reliability
- High Surge Current Capability

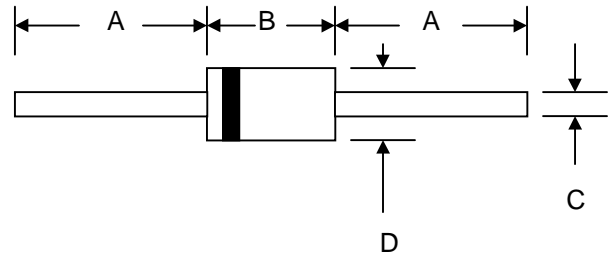

#### Mechanical Data

- Case: R-1, Molded Plastic
- Terminals: Plated Leads Solderable per MIL-STD-202, Method 208
- Polarity: Cathode Band
- Weight: 0.181 grams (approx.)
- Mounting Position: Any
- Marking: Type Number
- **Lead Free: For RoHS / Lead Free Version**

R-1		
Dim	Min	Max
A	20.0	—
B	2.90	3.50
C	0.53	0.64
D	2.20	2.60
All Dimensions in mm		

#### Maximum Ratings and Electrical Characteristics @ $T_A=25^\circ\text{C}$ unless otherwise specified

Single Phase, half wave, 60Hz, resistive or inductive load.

For capacitive load, derate current by 20%.

Symbol SF11G SF12G SF13G SF14G SF15G SF16G SF17G SF18G Unit

Characteristic	Symbol	1H1G	1H2G	1H3G	1H4G	1H5G	1H6G	1H7G	1H8G	Unit
Peak Repetitive Reverse Voltage	$V_{RRM}$									V
Working Peak Reverse Voltage	$V_{RWM}$	50	100	150	200	300	400	500	600	V
DC Blocking Voltage	$V_R$									V
RMS Reverse Voltage	$V_{R(RMS)}$	35	70	105	140	210	280	350	420	V
Average Rectified Output Current (Note 1)	$I_O$	1.0								A
Non-Repetitive Peak Forward Surge Current 8.3ms Single half sine-wave superimposed on rated load (JEDEC Method)	$I_{FSM}$	25								A
Forward Voltage @ $I_F = 1.0A$	$V_{FM}$	0.95			1.30		1.70			V
Peak Reverse Current @ $T_A = 25^\circ\text{C}$ At Rated DC Blocking Voltage @ $T_A = 100^\circ\text{C}$	$I_{RM}$	5.0				100				$\mu\text{A}$
Reverse Recovery Time (Note 2)	$t_{rr}$	35								nS
Typical Junction Capacitance (Note 3)	$C_j$	20				10				pF
Operating Temperature Range	$T_j$	-65 to +150								$^\circ\text{C}$
Storage Temperature Range	$T_{STG}$	-65 to +150								$^\circ\text{C}$

**\*Glass passivated forms are available upon request**

Note: 1. Leads maintained at ambient temperature at a distance of 9.5mm from the case

2. Measured with  $I_F = 0.5A$ ,  $I_R = 1.0A$ ,  $IRR = 0.25A$ . See figure 5.

3. Measured at 1.0 MHz and applied reverse voltage of 4.0V D.C.

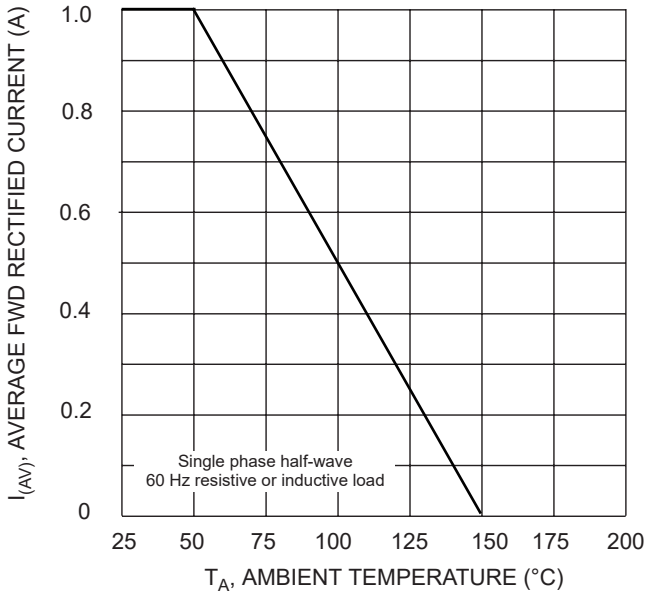

Fig. 1 Forward Derating Curve

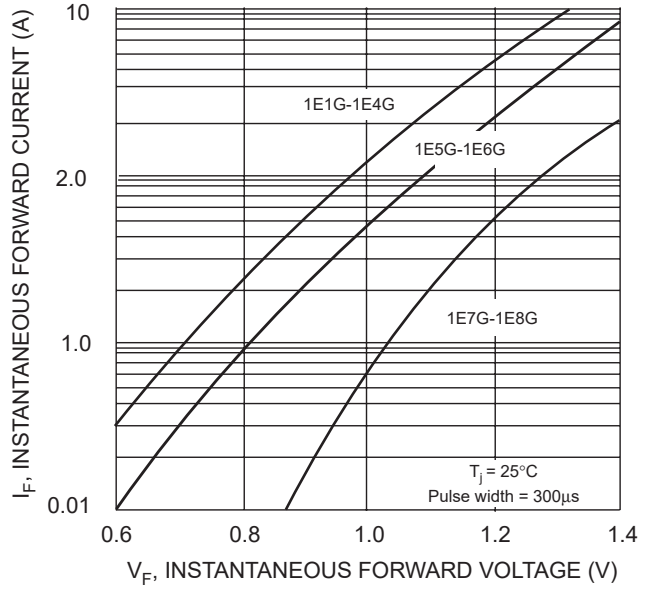

Fig. 2 Typical Forward Characteristics

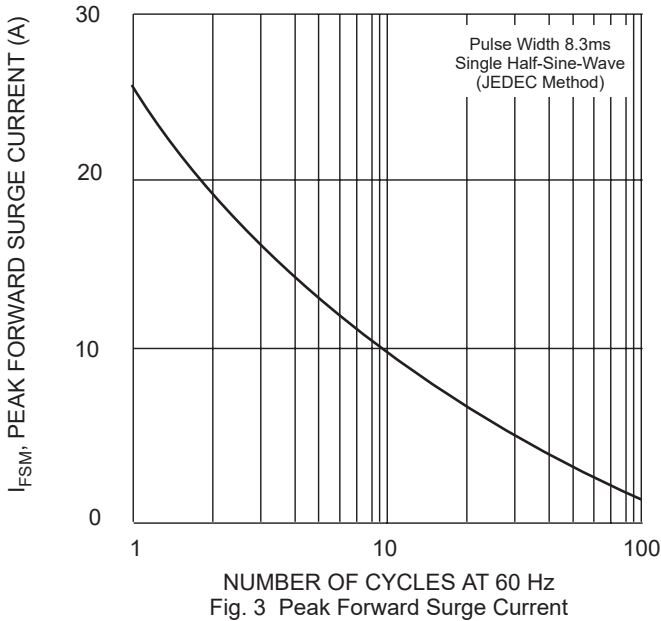

Fig. 3 Peak Forward Surge Current

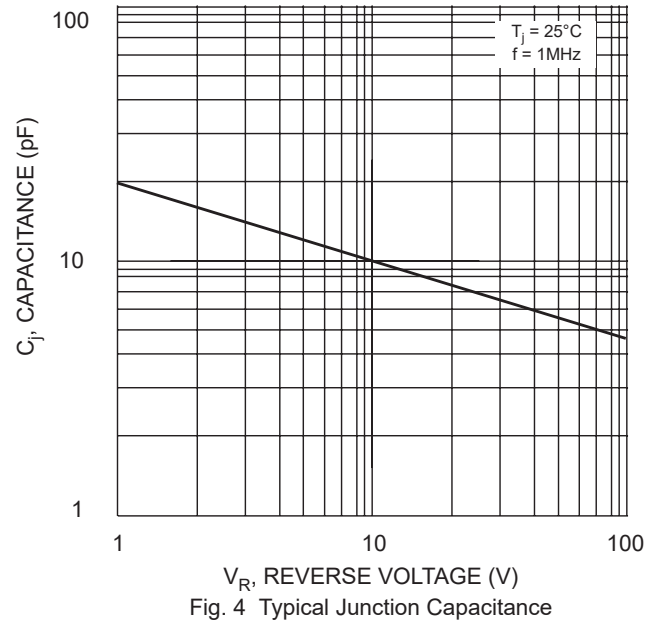
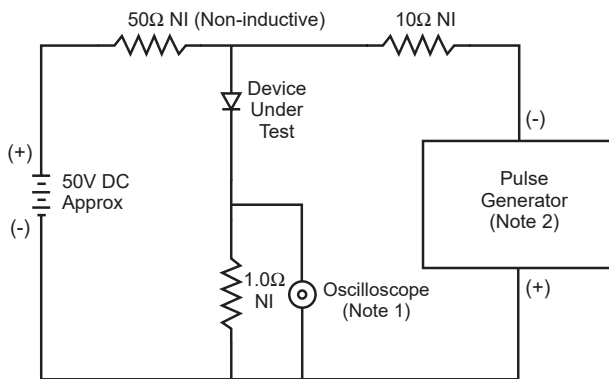
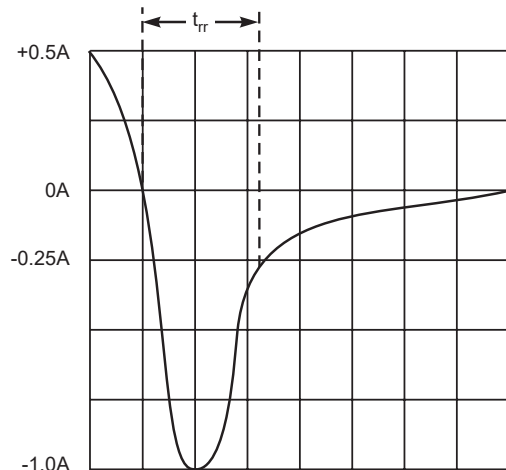

Fig. 4 Typical Junction Capacitance



- Notes:
1. Rise Time = 7.0ns max. Input Impedance = 1.0MΩ, 22pF.
  2. Rise Time = 10ns max. Input Impedance = 50Ω.

Fig. 5 Reverse Recovery Time Characteristic and Test Circuit



Set time base for 5/10ns/cm