

RoHS

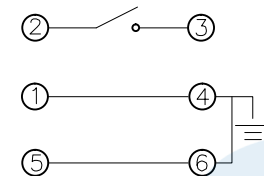

Circuit Diagram

PCB Layout (Pattern side)

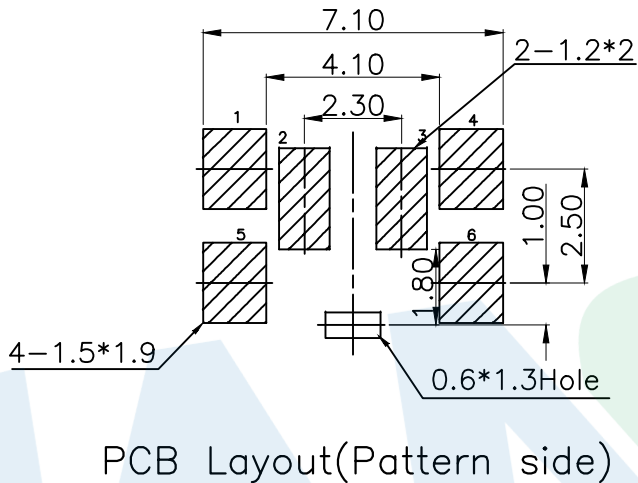
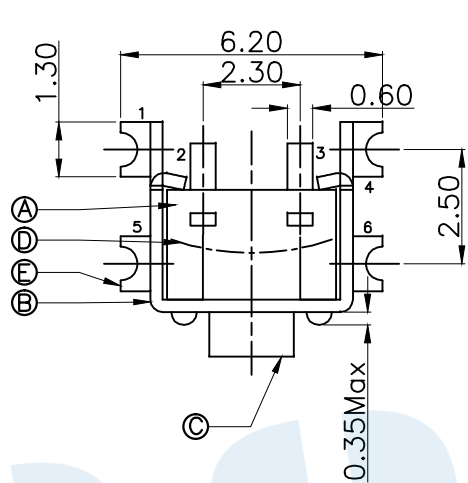
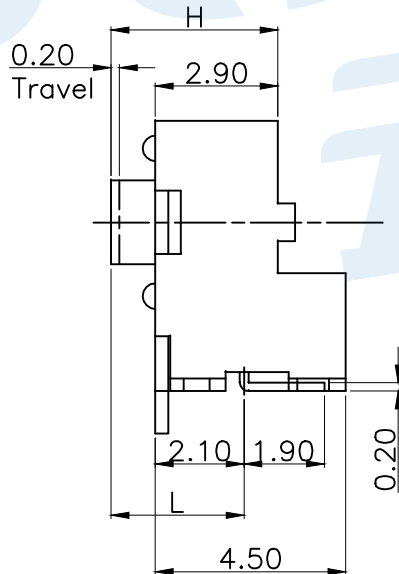
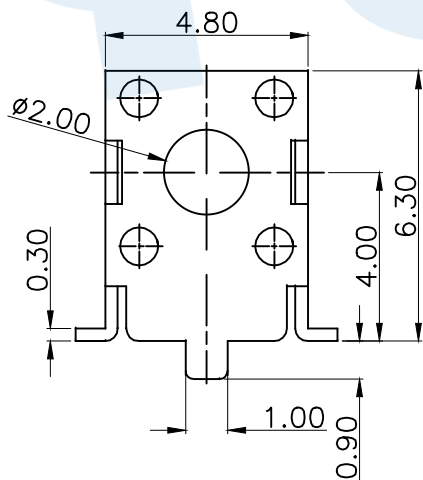

SHRAPNEL	
CODE	MATERIAL/QTY
D2	SUS/1PCS

OPERATING FORCE	
CODE	VIGOR
B2	180±30gf
B3	250±30gf

TOTAL HEIGHT		
CODE	H	L
A1	3.8	3.15
A2	4.3	3.65

NO.	Name	Number	Qty	Materil	Remarks
⑤	Terminal		2	Phosphours copper	Silvering
④	Reed		1	SUS	Silver covered
③	Button		1	PPA	Black
②	Cover		1	Brass	Ni plated
①	Base		1	PPA	Black

YUANDI® Yuandi Electronics Co, Ltd

design	date	name	TACT SWITCHS
Review	date	model	TS-1043-A□B□-D□
Approved	date		

Drawing number: Proportion 1:1 unit mm gage number A4

modify Review Approved Tolerance not specified

angle	±2'
10~30	±0.30
5~10	±0.20
~ 5	±0.10



1、总述 General

1.1 适用范围：此规格书规定了 TS 型轻触开关的有关要求。

Scope: this specification covers the requirements for TS TACKET SWITCH.

1.2 操作温度范围：-20℃~70℃（正常湿度，正常压力）

Operating temperature range: -20℃ to 70℃（normal humidity,normal press）

1.3 贮存温度范围：-30℃~80℃（正常湿度、正常压力）

Storage temperature range: -30℃ to 80℃（normal humidity,normal press）

1.4 测试条件：除非特别载明，一般情况下的测试及测量应按以下标准条件下进行。

正常温度（温度 5℃~35℃）

正常湿度（相对湿度 28~85%）

正常压力（86~106 Kpa）

在判定是否符合时，如有问题产生，则应按以下条件进行测试：

温度 20℃±2℃

相对湿度 65±5%

Test conditions: test and measurements shall be made in the following standard Conditions Unless otherwise specified.

Normal temperature (temerature 5℃ to 35℃)

Normal humidity (relative humidity 28 to 85%)

Normal pressure (86 to 106 K a)

In case any question arises from the judgement made,tests shall be conducted in the

Following Conditions:

Temperature 20℃±2℃

Relative humidity 65±5%

2、外观、型号及尺寸:

Appearance, style, and dimensions

2.1 外观：应无任何影响产品性能的毛疵。

Appearance there shall be no defects that affect the serviceability of the product.

2.2 型号及尺寸：应符合装配图纸的要求。

Style and dimensions shall conform to the assembly drawings.

3、开关驱动方式：轻触开关。

Switch drive mode: tact switch.

4、额 定：DC 12V 50mA

Rating : DC 12V 50mA

标记 SIGN	处 数 QUANTITY	更改文件号 FILENUMBER	签 名 NAME	日 期 DATE	标记 SIGN	处 数 QUANTITY	更改文件号 FILENUMBER	签 名 NAME	日 期 DATE



# 东莞市元迪电子有限公司

## Dongguan YuDing Electronic Co.,Ltd

5、特性 Performance									
5.1 电气性能 Electrical									
项目 Item	测试条件 Test conditions						要求 Requirements		
5.1.1 接触电阻 Contact resistance	施加 2 倍于动作力的静负荷在心轴上，用 1 千赫小电流接触电阻计来测量。 Applying a static load twice the actuating force to the center of the stem, measurements shall be made with a 1 kHz small-current contact resistance meter.						100mΩ 最大值 100mΩ max		
5.1.2 绝缘电阻 Insulation resistance	在端子之间以及在端子和壳体之间施加 DC 250V 时间 1 分钟。 Measurements shall be made following application of DC 250V potential across terminals and across terminals and frame for one minute.						100MΩ 最小值 100MΩ min		
5.1.3 绝缘耐压 Dielectric withstanding	在端子之间以及端子和壳体之间施加 AC 250V (50Hz 或 60Hz) 1 分钟 AC 250V(50Hz or 60Hz) shall be applied across terminal and across terminals and frame for one minute.						无击穿和飞弧现象 there shall be no breakdown		
5.1.4 振动 Bounce	轻击心轴，以每秒 3~4 次的轻击频率进行，在“开”及“关”处进行振动测量 Lightly striking the center of the stem at a rate encountered in normal use 3 to 4 operations per sec) bounce shall be tested at “on” and “off”.						10m/秒最大值 10m sec max		
5.2 机械性能 Mechanical Performance									
项目 Item	测试条件 Test conditions						要求 Requirements		
5.2.1 动作力 Actuating force	放置开关，使它的操作方向是垂直的，然后逐渐将负荷增大施加在轴的中心，当负荷达到轴的最大承受度时，测得 Placing the switch such that the direction of switch operation is vertical and then gradually increasing the load applied to the center of the stem, the maximum load required for the stem to come to a stop shall be measured						按压力 250gf±30gf Pushforce 250gf±30gf		
5.2.2 行程 Travel	放置开关，使它的操作方向是垂直的，然后向轴的中心施加 2 倍于开关按压力的静负荷，直至轴杆停止时所测得的行程。 Placing the switch such that the direction of switch operation is vertical and then applying a static load twice the actuating force to the center of the stem, the travel distance for the stem to come to a stop shall be measured.						0.20±0.10mm		
5.2.3 回程力 Return force	安装固定开关，使它的操作方向是垂直的，依照在它中心的轴杆的下降，整个行程，测量其返回至自由位置上所需的力。 The sample switch is installed such that the direction of switch operation is vertical nad, upon depression of the stem in its center the whole travel distance, the force of the stem to return to its free position shall be measured.						回弹力 50gf 最小值 Return force 50gf min		
标记 SIGN	处数 QUANTITY	更改文件号 FILENUMBER	签名 NAME	日期 DATE	标记 SIGN	处数 QUANTITY	更改文件号 FILENUMBER	签名 NAME	日期 DATE



# 东莞市元迪电子有限公司

## Dongguan YuDing Electronic Co.,Ltd

5.2.4 止动力 Stop strength	<p>放置开关，使它的操作方向是垂直的，沿轴杆方向施加 3 千克力的静负荷，时间 60 秒</p> <p>Placing the switch such that the direction of switch operation is vertical, a static load of 3 kgf shall be applied in the direction of stem operation for a period of 60seconds.</p>	<p>应无机械或电气性能的损坏迹象出现</p> <p>There shall be no sign of damage mechanically .</p>
5.2.5 按柄强度 Stem strength	<p>放置开关，使其操作方向是垂直的，在轴杆运作的相反方向施加一拔力，测量其最大的耐受力。</p> <p>Placing the switch such that the direction of switch operation is vertical,the maximum force to withstand a pull applied opposite to the direction of stem operation shall be measured.</p>	3Kgf

### 5.3 环境 Environmental

项目 Item	测试条件 Test conditions	要求 Requirements
5.3.1 耐低温 Resistance To low temperatures	<p>依照以下设定的测试，在测量之前样品应放置在正常温度/湿度条件下 1 小时，然后：(1)温度-30℃±2℃(2)时间 96 小时(3)应抹去水滴</p> <p>Following the test set forth below the sample shall be left in normal temperature and humidity conditions for 1 hour before measurements are made:(1)temperature -30 °C ±2 °C (2)time 96 hours (3)waterdrops shall be removed.</p>	<p>应符合 5.1、5.2.1、5.2.2 项目中的要求</p> <p>item 5.1 item 5.2.1 item 5.2.2</p>
5.3.2 耐热性 Heat resistance	<p>依照以下设定的测试，在测量之前样品应放置在正常温度/湿度条件下 1 小时，然后：(1)温度 80℃±2℃(2)时间 96 小时</p> <p>Following the test set forth below the sample shall be left in normal temperature and humidity conditions for one hour before measurements Are made:(1)temperature 80℃±2℃(2)time 96 hours</p>	<p>应符合 5.1、5.2.1、5.2.2 项目中的要求</p> <p>item 5.1 item 5.2.1 item 5.2.2</p>
5.3.3 耐湿性 Moisture resistance	<p>依照以下设定的测试，在测量之前样品应放置在正常温度/湿度条件下 1 小时，然后：(1)温度 60℃±2℃ (2)相对湿度 90~95% (3)时间 96 小时 (4)应抹去水滴</p> <p>Following the test set forth below the sample shall be left in normal temperature and humidity conditions for one hour before measurements are made: (1)temperature 60℃±2℃ (2)relative humidity 90 to 95% (3)time 96 hours (4) waterdrops shall be removed</p>	<p>接触电 50mΩ 最大值 绝缘电 10MΩ 最小值 应符 5.1.3 、 5.1.4 、 5.2.1、5.2.2 项目中的要求</p> <p>contact resistance 50mΩ max insulation resistance 10MΩ min item 5.1.3 item 5.1.4 item 5.2.1 item 5.2.2</p>

标记 SIGN	处数 QUANTITY	更改文件号 FILENUMBER	签名 NAME	日期 DATE	标记 SIGN	处数 QUANTITY	更改文件号 FILENUMBER	签名 NAME	日期 DATE

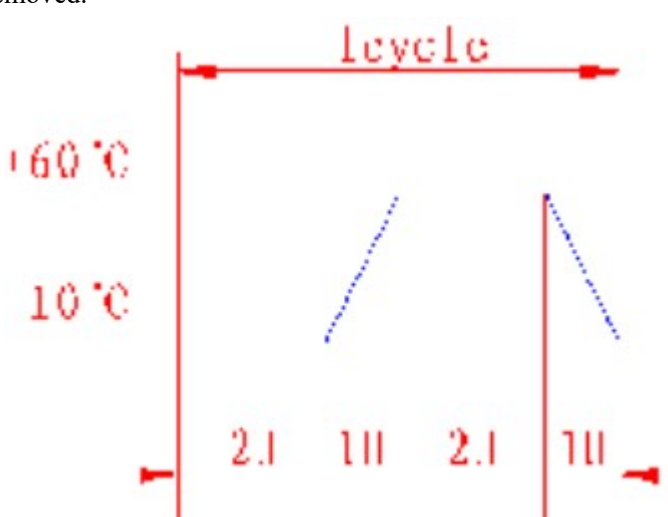
<p>5.3.4 温度循环 Temperature cycling</p>	<p>依照以下设定的测试,在测量之前样品应放置在正常温度/湿度条件下 1 小时, 然后进行 5 个测试循环, 测试期间应抹去水滴。 Following five cycles of the temperature cycling test set forth below the sample shall be left in normal temperature and humidity measurements for one hour before measurements are made during this test, waterdrops shall be removed.</p> 	<p>应符合 5.1、5.2.1、5.2.2 项目中的要求 item 5.1 item 5.2.1 item 5.2.2</p>
---	---	--

5.4 耐久 Endurance

项目 Item	测试条件 Test conditions	要求 Requirements
<p>5.4.1 使用寿命 Operating life</p>	<p>应依照以下所设定的测试条件进行测试: (1)DC 12V 50mA 电阻负荷 (2)操作频率: 2~3 次/秒 (3)下降: 1 倍于驱动力 (4)操作次数: 50,000 次</p> <p>Measurements shall be made following the test set forth below: (1)DC 12V 50mA resistive load (2)Rate of operation: 2 to 3 (3)Depression: One the actuating force (4)Cycles of operation:50,000 cycles</p>	<p>接触电 100mΩ 最大值 绝缘电阻 10MΩ 最小值 振动 10m/秒最大值 驱动力±30%或初始力应符合 5.1.3、5.2.2 项目中的要求 contact resistance 100mΩmax insulation resistance10MΩ min bounce 10m/sec max actuating force item 5.1.3 item 5.2.2</p>

标记 SIGN	处数 QUANTITY	更改文件号 FILENUMBER	签名 NAME	日期 DATE	标记 SIGN	处数 QUANTITY	更改文件号 FILENUMBER	签名 NAME	日期 DATE

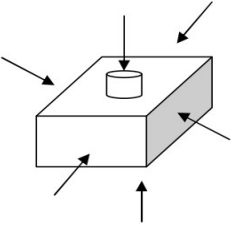
<p>5.4.2 耐振性 Vibration resistance</p>	<p>应依照以下设定的测试条件进行测试： (1)振荡范围：10~55Hz (2)振幅：1.5mm (3)摆动次数：10~55 10Hz(约 1 分钟) (4)摆动方式：对数摆动或均匀摆动 (5)振荡方向：三个相互垂直方向包括轴杆行程方向 (6)测试时间：各 2 小时，共 6 小时 Measurements shall be made following the test set forth below: (1) Range of oscillation: 10 to 55 Hz (2) Amplitude,pk-to-pk: 1.5 mm (3) Cycle of sweep: 10-55 10 Hz (in one minute approx) (4) Mode of sweep: logarithmical sweep or uniform sweep (5) Direction of oscillation: three mutually perpendicular directions, including the direction of stem travel Duration of testing: 2 hours each for a total of 6 hours</p>	<p>应符合 5.1、5.2.1、5.2.2 项目中的要求 item 5.1 item 5.2.1 item 5.2.2</p>							
<p>5.4.3 耐碰撞冲击 Impact shock</p>	<p>应依照以下设定的测试条件进行测试： (1)加速度：80 G (2)测试次数：每个方向 3 次，共 6 个方向 18 次 Measurements shall be made following the test set forth below: (1)Acceleration: 80 G (2)Cycles of test: 3 cycles each in 6 directions for a totsl of 18 cycles</p> <div style="text-align: center;">  </div>	<p>应符合 5.1、5.2.1、5.2.2 项目中的要求 item 5.1 item 5.2.1 item 5.2.2</p>							
<p>5.4.4 可焊性 Solderability</p>	<p>端子顶部被浸入锡池中 2mm 深，温度为 250±2℃，时间为 3±0.5 秒。 The tip of the terminals shall be dipped 2mm in the solder bath at a temperature of 250±2℃ for 3±0.5 seconds.</p>	<p>浸入部分的 75%以上表面被焊锡覆盖 应符合 5.1、5.2 项目中的要求 A new uniform coating of solder shall cover a minnum of 75% of the surface being immersed item 5.1、item 5.2</p>							
<p>标记 SIGN</p>	<p>处数 QUANTITY</p>	<p>更改文件号 FILENUMBER</p>	<p>签名 NAME</p>	<p>日期 DATE</p>	<p>标记 SIGN</p>	<p>处数 QUANTITY</p>	<p>更改文件号 FILENUMBER</p>	<p>签名 NAME</p>	<p>日期 DATE</p>

5.4.5 耐焊接热  
Resistance to  
soldering heat test

开关置于锡焊装置中，温度为  $250 \pm 5^\circ\text{C}$ ，时间为  $3 \pm 0.5$  秒。  
The switch is placed in the soldering device, and the temperature is  $250^\circ\text{C}$ , for  $3 \pm 0.5$  seconds.

开关未被破坏，机械及电气性能可被满足。  
应符合 5.1、5.2 项目中的要求  
Switch without harmful damage, mechanical and electrical characteristics shall be satisfied.  
item 5.1  
item 5.2 item 2.1

6、回流焊接 Reflow soldering

在 PCB（印刷线路板）进入焊接设备中之后的  $2 \pm 0.3$  分钟，铜片表面的预热温度应达到  $180^\circ\text{C}$ 。  
在 PCB 进入焊接热区域中之后的 20 秒之内，铜片表面的焊接热温度应达到  $250^\circ\text{C}$  的高峰温度。

Preheat-Temperature on the copper foil surface should reach  $180^\circ\text{C}$ ,  $2 \pm 0.3$  minutes after the PCB entered into the soldering equipment. Soldering heat Temperature on the copper foil surface should reach the peak temperature of  $250^\circ\text{C}$  within 20 seconds after the PCB entered into soldering heat zone.

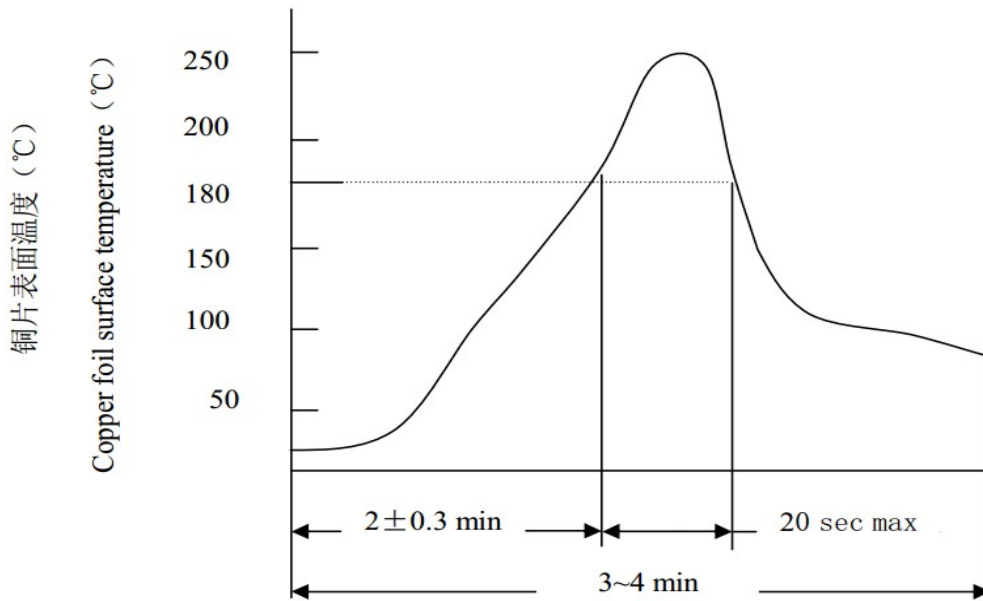

在边焊设备中的时间

温度变化图

Time in side soldering equipment

Temperature profile

标记 SIGN	处数 QUANTITY	更改文件号 FILENUMBER	签名 NAME	日期 DATE	标记 SIGN	处数 QUANTITY	更改文件号 FILENUMBER	签名 NAME	日期 DATE
------------	----------------	---------------------	------------	------------	------------	----------------	---------------------	------------	------------

开关注意事项

SWITCH HANDLING PRECAUTIONS

1、 如果使用自动流焊装置时，应依照以下条件：

In case an automatic flow soldering apparatus is used for soldering, adhere to the following conditions:

项目 Item	焊接条件 Soldering condition
手工焊接 Hand soldering	① 焊接温度：350 °C 最大值；②连续焊接时间：3 秒 最大值 ①Solding temperature: 350 °C Max; ②Continuoussoldering time: 3S Max
自动浸焊 Conditfons for Auto-dip	
①预热温度 Preheat temperature	100°C 最大值（在它的焊接一侧印刷电路板的环境温度） 100°C max(Ambient temperature of printed circuit board on its soldering side)
②预热时间 Preheat time	45 秒 最大值 45sec Max
③焊剂起泡 Flux foaming	这种情况下，焊剂应被平焊与安装有元器件的印刷电路板齐平。焊剂不能施加在装配有元器件的印刷线路板一侧或者端子的区域。 To such an extent that flux will be kept flush with the printed circuit board's top surface on which comp-onens are mounted.Preparatory flux must not be applied to that side of print circuit board on which components are mounted to the area where terminals are located.
④焊接温度 Soldering temperature	250°C 最大值 250°C Max
⑤浸焊时间 Durationofsolder Immersion	3 秒 最大值 3sec max
⑥允许焊接次数 Frequency soldering process	2 次 最多 2 times max

2、 其它注意事项：

(1) 请按焊接工序，不要试着用洗涤剂或类似物来清洗开关。

(2) 防止焊剂从顶部影响到开关的装配。

Other precautions

(1) Following the soldering process, do not try to clean the switch with a solvent or the like.

Safeguard the switch assembly against flux penetration from its top side.

标 记 SIGN	处 数 QUANTITY	更改文件号 FILENUMBER	签 名 NAME	日 期 DATE	标 记 SIGN	处 数 QUANTITY	更改文件号 FILENUMBER	签 名 NAME	日 期 DATE