



- Features :
 - Universal AC input / Full range
 - Built-in active PFC function
 - Protections: Short circuit / Overload / Over voltage / Over temperature
 - Forced air cooling by built-in DC fan
 - Output voltage programmable from 20~110% by 1~5.5VDC external control signal
 - With DC OK Signal output
 - Built-in remote ON-OFF control
 - Fixed switching frequency at PFC:88KHz PWM:100KHz
 - 3 years warranty



SPECIFICATION

MODEL	SPV-600-12	SPV-600-24	SPV-600-48	
OUTPUT	DC VOLTAGE	12V	24V	48V
	RATED CURRENT	50A	25A	12.5A
	CURRENT RANGE	0 ~ 50A	0 ~ 25A	0 ~ 12.5A
	RATED POWER	600W	600W	600W
	RIPPLE & NOISE (max.) Note.2	240mVp-p	240mVp-p	300mVp-p
	VOLTAGE ADJ. RANGE	10 ~ 13.2V	20 ~ 26.4V	41 ~ 56V
	VOLTAGE TOLERANCE Note.3	±1.0%	±1.0%	±1.0%
	LINE REGULATION	±0.5%	±0.5%	±0.5%
	LOAD REGULATION	±0.5%	±0.5%	±0.5%
	SETUP, RISE TIME	1500ms, 50ms at full load		
HOLD UP TIME (Typ.)	20ms at full load			
INPUT	VOLTAGE RANGE Note.4	88 ~ 264VAC	124 ~ 370VDC	
	FREQUENCY RANGE	47 ~ 63Hz		
	POWER FACTOR (Typ.)	0.95/230VAC	0.99/115VAC at full load	
	EFFICIENCY(Typ.)	84%	86%	87%
	AC CURRENT (Typ.)	6.8A/115VAC	3.4A/230VAC	
	INRUSH CURRENT (Typ.)	20A/115VAC	40A/230VAC	
	LEAKAGE CURRENT	<1.3mA/240VAC		
PROTECTION	OVERLOAD	105 ~ 135% rated output power Protection type : Constant current limiting, recovers automatically after fault condition is removed		
	OVER VOLTAGE	13.8 ~ 16.2V	27.6 ~ 32.4V	57.6 ~ 67.2V
	OVER TEMPERATURE	85°C (TSW1) detect on heatsink of power transistor; 80°C (TSW51) detect on heatsink of power diode Protection type : Shut down o/p voltage, re-power on to recover		
FUNCTION	REMOTE CONTROL	RC+/RC-: Short = power on ; Open = power off		
	POK SIGNAL	PSU turn on: 3.3V ~ 5.6V PSU turn off: 0V ~ 1V		
	OUTPUT VOLTAGE TRIM	2.4 ~ 13.2V	4.8 ~ 26.4V	9.6 ~ 52.8V
ENVIRONMENT	WORKING TEMP.	-20 ~ +60°C (Refer to output load derating curve)		
	WORKING HUMIDITY	20 ~ 90% RH non-condensing		
	STORAGE TEMP., HUMIDITY	-40 ~ +85°C, 10 ~ 95% RH		
	TEMP. COEFFICIENT	±0.03%/°C (0 ~ 50°C)		
	VIBRATION	10 ~ 500Hz, 2G 10min./1cycle, period for 60min. each along X, Y, Z axes		
SAFETY	SAFETY STANDARDS	Design refer to UL60950-1, TUV EN60950-1		
	WITHSTAND VOLTAGE	I/P-O/P:3KVAC I/P-FG:1.5KVAC O/P-FG:0.5KVAC		
	ISOLATION RESISTANCE	I/P-O/P, I/P-FG, O/P-FG:100M Ohms / 500VDC / 25°C / 70% RH		
OTHERS	MTBF	116.4K hrs min. MIL-HDBK-217F (25°C)		
	DIMENSION	170*120*93mm (L*W*H)		
	PACKING	1.9Kg; 8pcs/15.5Kg/1.06CUFT		
NOTE	1. All parameters NOT specially mentioned are measured at 230VAC input, rated load and 25°C of ambient temperature. 2. Ripple & noise are measured at 20MHz of bandwidth by using a 12" twisted pair-wire terminated with a 0.1uf & 47uf parallel capacitor. 3. Tolerance : includes set up tolerance, line regulation and load regulation. 4. Derating may be needed under low input voltages. Please check the derating curve for more details.			

Mechanical Specification

Case No.910A Unit:mm

Terminal Pin No. Assignment

Pin No.	Assignment
1	AC/L
2	AC/N
3	FG \perp
4	PV
5	POK
6	R.C. G
7	R.C.
8~11	DC OUTPUT +V
12~15	DC OUTPUT -V

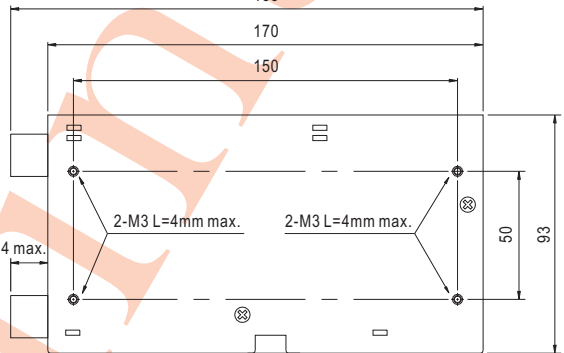
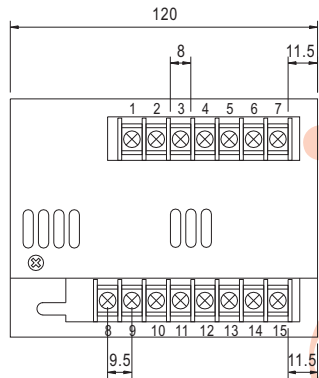
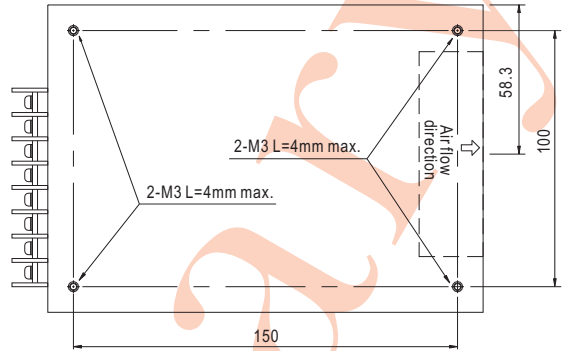

Block Diagram

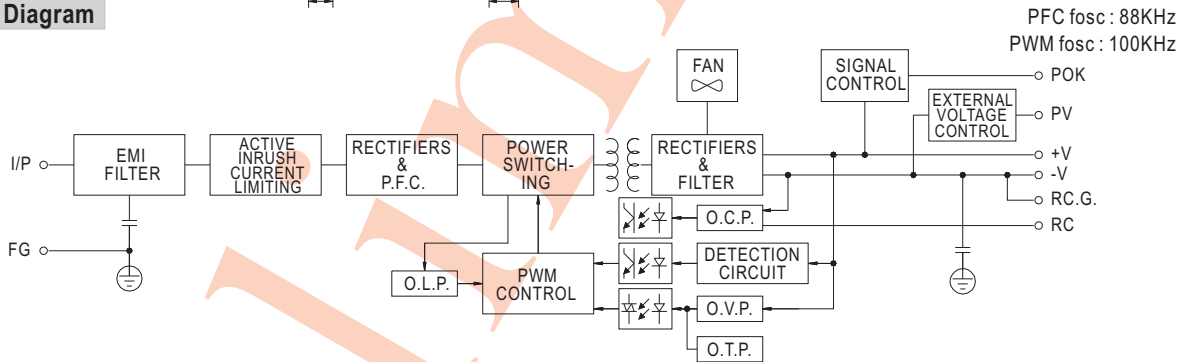

Derating Curve

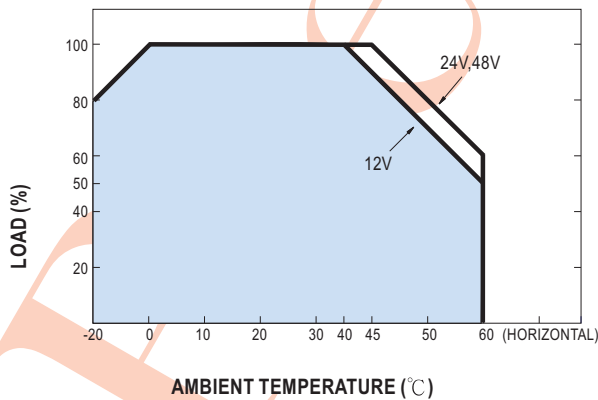

Output Derating VS Input Voltage

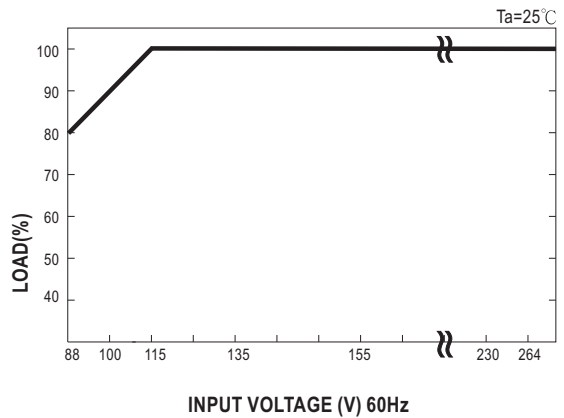

Control Terminal Instruction Manual

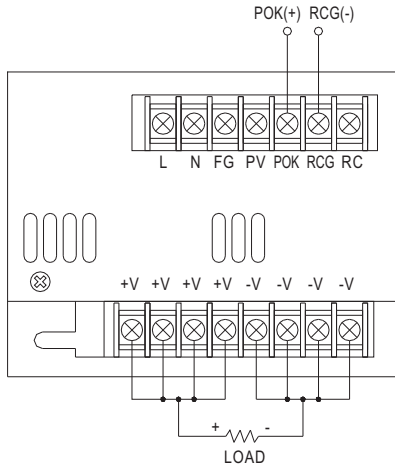

POK Signal

POK Signal is the voltage difference between "RCG" and "POK" pin output POK Signal for TTL level signal
 PSU turn on: 3.3V ~ 5.6V
 PSU turn off: 0V ~ 1V

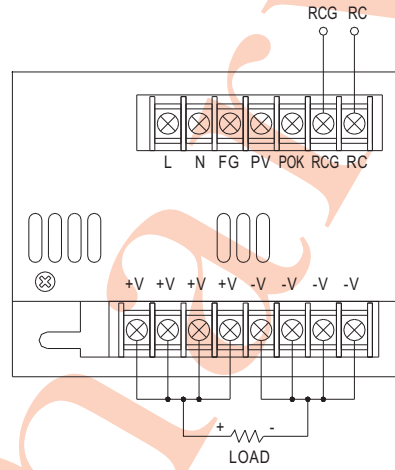

Remote Control

Power ON: RCG and RC for short
 Power OFF: RCG and RC for open

Function Manual

1. External Voltage Control

