

HSF

NOTES:

- 1.Electrical Performance:
- 1-1.Current Rating:0.5 A at AC 100V.
- 1-2.Withstand Voltage:250V AC.
- 1-3.Contact Resistance:See Table.
- 1-4.Insulation Resistance:1000MΩ Min.
- 1-5.Operation Temperature:-55°Cto+85°C
- 2.Material:
- 1.Housing:LCP;Black/Natural;UL94V-0.
- 2-2.Contact:Phosphor Bronze,T=0.20mm.
- 2-3.Fitting Nail:Brass,T=0.25mm.
- 2-4.Metal Cap :Stainless Steel,T=0.20mm.
- 3.Finish:
- 3-1.Contact:Gold Plating On Contact Area;  
Matte Tin Plating On Solder Tails Over Ni.
- 3-2.Fitting Nail:Sn Plating Over, Ni Under Plating

**Ordering Information**

3660-S XXX - 124 XX R 0X

No.of Pins	Housing High	Contact Plating	R=Tape&Reel+CAP
		G1=3u"Gold	
		G2=5u"Gold	
		G3=10u"Gold/Tin	
		S1=3u"Gold/Tin	
		S2=5u"Gold/Tin	
		S3=10u"Gold/Tin	

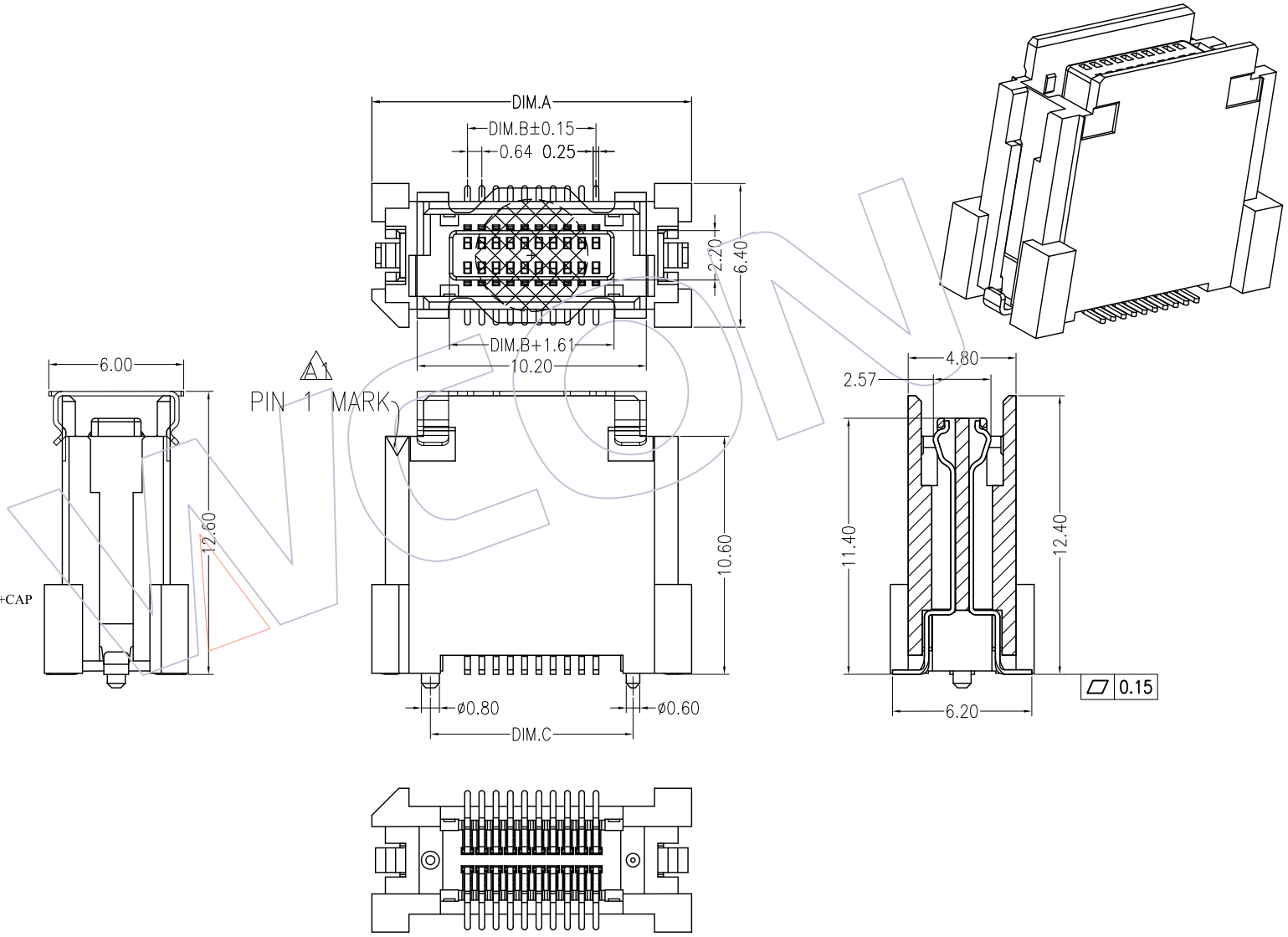

REV	DATE	MODIFICATION DESCRIPTION	CHANGE	OPERATION		DRAW	DATE	SCALE	FIT	PART NO.
				X.X	±0.40					
A1	2017.03.22	ADD PIN 1 MARK	△	X.XX	±0.25	CHECK	DATE	SIZE	A4	TITLE:
A0	2015.10.21	NEW	—	X.XXX	±0.15	APPROVE	DATE	SHEET	1/2	0.635mm BTB "M" FEMALE
				Angle	± 3'			PROJ.	Customer NO.	SMT TYPE
				DIM	TOL					

**WCON**  
Http: www.wcon.com

WCON-Dongguan Tel: +86 769 85358920 Fax: +86 769 85358915 E-mail: sales@wcon.com	WCON-Kunshan Tel: +86 512 57468408 Fax: +86 512 57468468 E-mail: salesks@wcon.com
---	--

# HSF

**NOTES:**

- 1.Electrical Performance:
  - 1-1.Current Rating:0.5 A at AC 100V.
  - 1-2.Withstand Voltage:250V AC.
  - 1-3.Contact Resistance:See Table.
  - 1-4.Insulation Resistance:1000MΩ Min.
  - 1-5.Operation Temperature:-55°Cto+85°C
- 2.Material:
  - 1.Housing:LCP;Black/Natural;UL94V-0.
  - 2-2.Contact:Phosphor Bronze,T=0.20mm.
  - 2-3.Fitting Nail:Brass,T=0.25mm.
  - 2-4.Metal Cap :Stainless Steel,T=0.20mm.
- 3.Finish:
  - 3-1.Contact:Gold Plating On Contact Area;  
Matte Tin Plating On Solder Tails Over Ni.
  - 3-2.Fitting Nail:Sn Plating Over, Ni Under Plating

Recommended P.C.B Layout(Top Side)  
(PCB BOARD TOLERANCE±0.05)

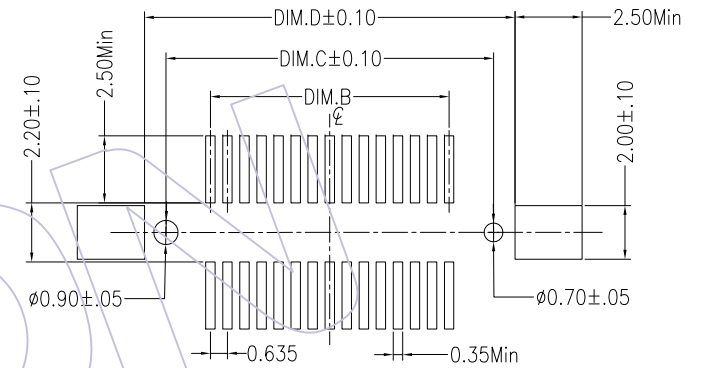
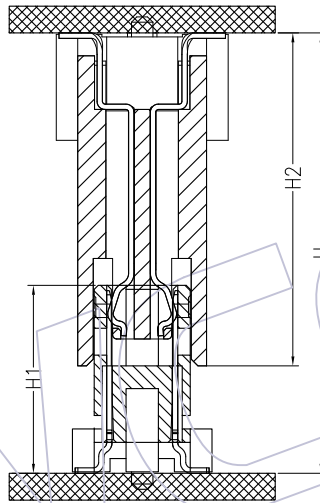

Assembly

## Ordering Information

3660-S XXX - 124 XX R 0X

No.of Pins    Housing High    Contact Plating    R=Tape&Reel+CAP

G1=3u"Gold  
G2=5u"Gold  
G3=10u"Gold/Tin  
S1=3u"Gold/Tin  
S2=5u"Gold/Tin  
S3=10u"Gold/Tin

ASS'Y HIGH(H)	Before Test	After Test
13.40	≤70mΩ	≤90mΩ
14.40		
15.40		
16.40	≤80mΩ	≤100mΩ
17.40		

ASS'Y HIGH(H)	PLUG(H1)	SOCKET(H2)
13.40	5.00	12.40
14.40	6.00	
15.40	7.00	
16.40	8.00	
17.40	9.00	

NO	55.07	53.47	50.165	58.67	160
		48.72	47.12	43.815	52.32
	42.30	40.77	37.465	45.97	120
	36.02	34.42	31.115	39.62	100
	32.85	31.25	27.940	36.45	90
	29.67	28.07	24.765	33.27	80
YES	26.50	24.90	21.590	30.10	70
	23.32	21.72	18.415	26.92	60
	20.15	18.55	15.240	23.75	50
	16.97	15.37	12.065	20.57	40
	13.80	12.20	8.890	17.40	30
	10.62	9.02	5.715	14.22	20
HS'G LOCK	DIM.D	DIM.C	DIM.B	DIM.A	PIN NO.

REV	DATE	MODIFICATION DESCRIPTION	CHANGE	OPERATION		DRAW Ding	DATE 2017.03.22	SCALE UNIT	FIT mm inch	PART NO. 3660-SXXX-124XXR0X
				X.X	±0.40					
A1	2017.03.22	ADD PIN 1 MARK		X.XX	±0.25	CHECK	DATE	SIZE	A4	TITLE: 0.635mm BTB "M" FEMALE
A0	2015.10.21	NEW	—	X.XXX	±0.15	APPROVE	DATE	SHEET	2/2	SMT TYPE
				Angle	± 3'			PROJ.		Customer NO.

**WCON**  
Http: www.wcon.com

WCON-Dongguan    WCON-Kunshan  
Tel: +86 769 85358920    Tel: +86 512 57468408  
Fax: +86 769 85358915    Fax: +86 512 57468468  
E-mail: sales@wcon.com    E-mail: salesks@wcon.com