

Rev	AWO #	Description	Date	Appr
-		RELEASED	7/13/10	

APPROVED: \_\_\_\_\_ TITLE: \_\_\_\_\_  
 DATE: \_\_\_\_\_

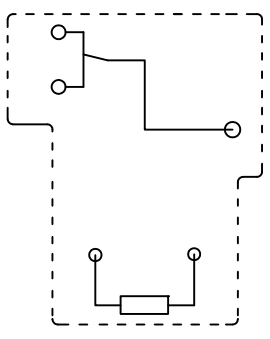
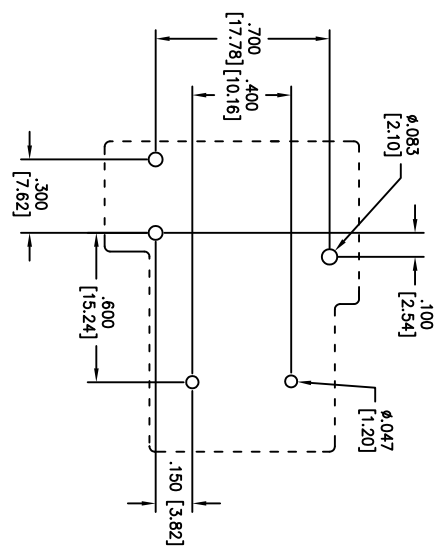
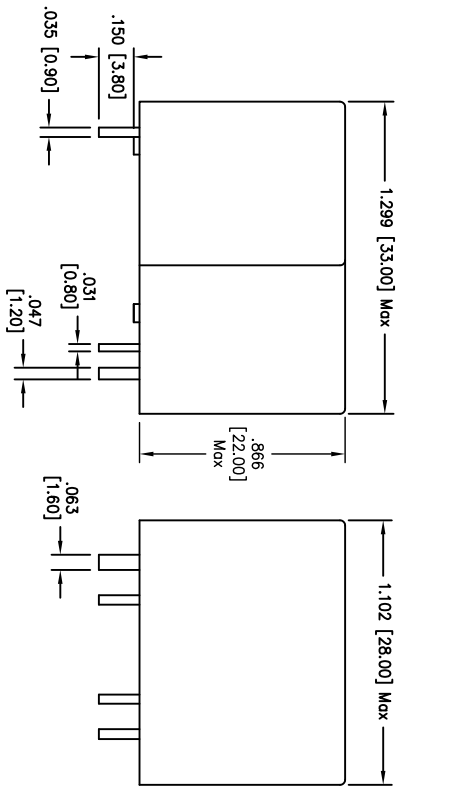

PART NO.	RPL-1C-P-48
Coil Rated Voltage	48VDC
Coil Rated Current	18.7mA
Pick-up Voltage	36VDC
Drop-out Voltage	4.8VDC
Coil Resistance	2560Ω

**SPECIFICATIONS:**

**Electrical:**

Contact arrangement: 1Z(SPDT)  
 Contact material: Ag Alloy  
 Contact Rating (Resistive load): 30A @ 250V AC 30A @ 30V DC  
 Max. Switching Voltage: 250V AC / 30V DC  
 Max. Operating Power: 7500VA  
 Contact resistance: 100 mΩ max. Initial  
 Insulation resistance: 100 MΩ min. @ 500V DC  
 Dielectric withstanding voltage:  
 Between Coil & Contact: 2000V AC 50/60HZ for 1 min.  
 Between Contacts: 1500V AC 50/60HZ for 1 min.  
 Operating time: 15ms max. Release time: 10ms max.  
 Electrical Life: 100,000 Operations (at rated load)

**Mechanical:**

Vibration resistance (Endurance): 1.5mm D.A. 10-55HZ  
 Shock resistance: 10G min.  
 Mechanical Life: 10,000,000 Operations (no load)  
 Terminal Strength: 500Gr. for 1 minute at horizontal direction  
 Temperature Rating: Ambient temperature: -55°C to +85°C  
 Environmental:  
 Lead free, RoHS compliant

Recommended soldering temp: 235°C for 5 sec.  
 Packaging: Anti-ESD plastic trays  
 Safety Agency Approvals: cUL Recognized File No. E305638

UNLESS OTHERWISE SPECIFIED  
 ALL DIMENSIONS ARE INCHES [MM]  
 TOLERANCES: EXCEPT AS NOTED

INCHES	HOLES
.X ± .10	ØX ± .10
.XX ± .020	ØXX ± .015
.XXX ± .015	ØXXX ± .010

APPROVALS		DATE
DRAWN	DY	7/13/10
CHECKED		
APPROVED		

**ADAM TECH**  
 909 Rahway Avenue, Union, NJ 07083  
 Phone: 908-687-5000 Fax: 908-687-5710

TITLE: MINIATURE SIGNAL RELAY,  
 48VDC COILS, 1Z, PCB PINS

SIZE	PART NO.	REV.
X	RPL-1C-P-48	-

REF: S00006C SCALE: NTS SHEET 1 OF 1