

Future Technology Devices International Ltd.

FT121 (Enhanced USB Device Controller with SPI Slave IC)

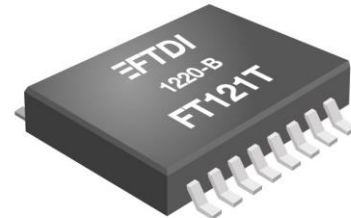

The FT121 is a USB generic interface controller with the following advanced features:

- USB 2.0 Full Speed compatible
- High performance USB device controller with integrated SIE, endpoint buffer, transceiver and voltage regulators
- Fully integrated clock generation with no external crystal required
- Supports Serial Parallel interface (SPI) slave to external microcontroller
- Supports up to 8 bi-directional endpoints with total 2k bytes endpoint buffer
- Max packet size is 504 bytes for isochronous endpoint and 64 bytes for control/bulk/interrupt endpoint
- Double buffer scheme for any endpoint increases data transfer throughput
- Multiple interrupt modes to facilitate both bulk and isochronous transfers
- USB Battery Charger detection allowing optimized charging profile
- Integrated DP pull-up resistor for USB connection
- Supports bus-powered or self-powered applications
- VCC power supply operation at 3.3V or 5V
- Internal 1.8V and 3.3V LDO regulators
- VCC IO level range from 1.8V to 3.3V
- Integrated power-on-reset circuit
- UHCI/OHCI/EHCI host controller compatible
- -40°C to 85°C extended operating temperature range
- Available in Pb-free TSSOP-16 and QFN-16 packages (RoHS compliant)

Neither the whole nor any part of the information contained in, or the product described in this manual, may be adapted or reproduced in any material or electronic form without the prior written consent of the copyright holder. This product and its documentation are supplied on an as-is basis and no warranty as to their suitability for any particular purpose is either made or implied. Future Technology Devices International Ltd will not accept any claim for damages howsoever arising as a result of use or failure of this product. Your statutory rights are not affected. This product or any variant of it is not intended for use in any medical appliance, device or system in which the failure of the product might reasonably be expected to result in personal injury. This document provides preliminary information that may be subject to change without notice. No freedom to use patents or other intellectual property rights is implied by the publication of this document. Future Technology Devices International Ltd, Unit 1, 2 Seaward Place, Centurion Business Park, Glasgow G41 1HH United Kingdom. Scotland Registered Company Number: SC136640

1 Typical Applications

- Provide USB port to Microcontrollers
- USB Industrial Control
- Mass storage data transfers for multitude of embedded systems applications, including medical, industrial data-logger, power-metering, and test instrumentation
- Provide USB port to FPGA's
- Utilising USB to add system modularity
- Isochronous support for video applications in security, industrial control, and quality inspections

1.1 Part Numbers

| Part Number | Package |
|-------------|----------|
| FT121T-x | TSSOP-16 |
| FT121Q-x | QFN-16 |

Note: Packaging codes for x is:

- R: Taped and Reel, (TSSOP is 2,500pcs per reel, QFN is 6,000pcs per reel).
- U: Tube packing, 96pcs per tube (TSSOP only)
- T: Tray packing, 490pcs per tray (QFN only)

For example: FT121T-R is 2,500pcs taped and reel packing

1.2 USB Compliant

At the time of writing this datasheet, the FT121 was in the process of completing USB compliance testing.

2 Block Diagrams

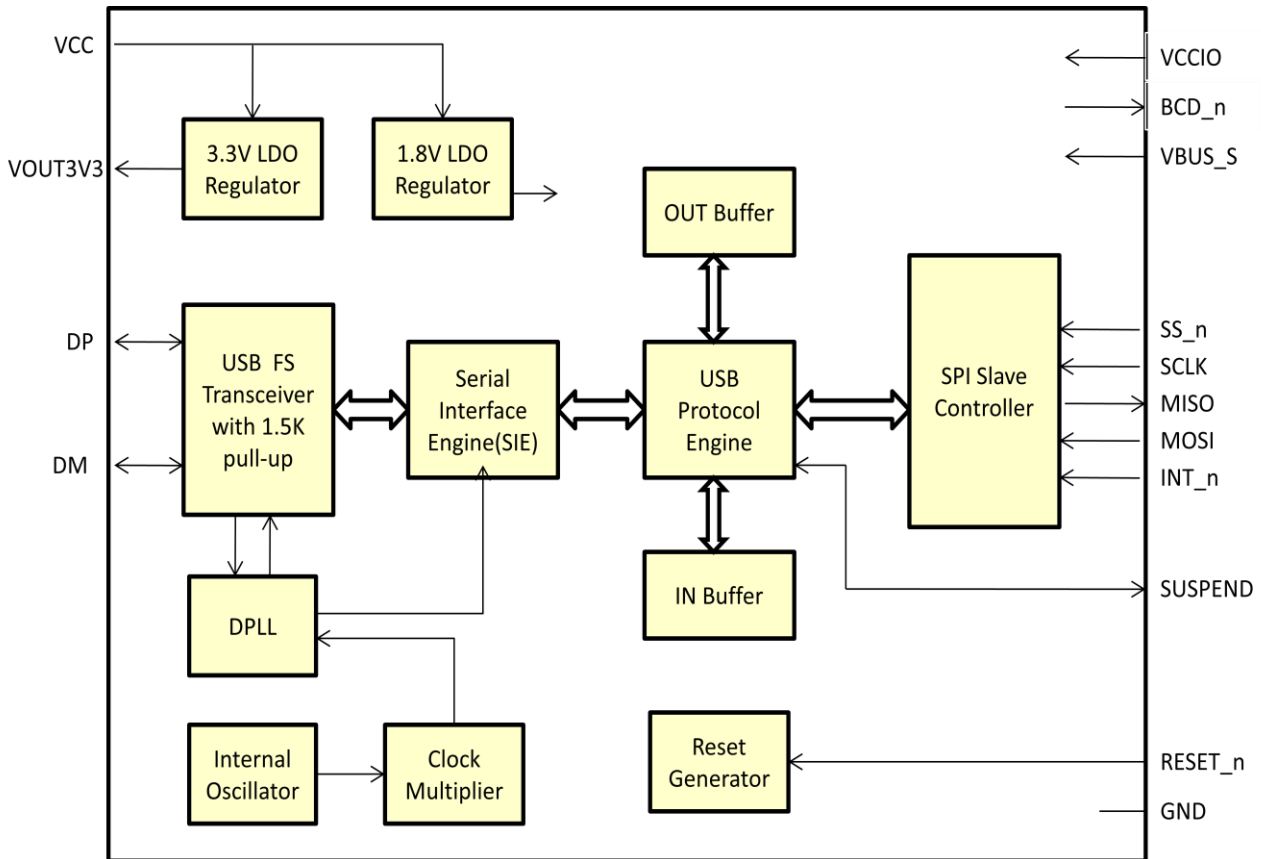

Figure 2-1 FT121 Block Diagram

For a description of each function please refer to Section 4.

Table of Contents

| | | |
|----------|--|-----------|
| 1 | Typical Applications..... | 2 |
| 1.1 | Part Numbers..... | 2 |
| 1.2 | USB Compliant..... | 2 |
| 2 | Block Diagrams | 3 |
| 3 | Device Pin Out and Signal Description..... | 6 |
| 3.1 | TSSOP-16 Package Pin Out..... | 6 |
| 3.2 | QFN-16 Package Pin Out..... | 6 |
| 3.3 | Pin Description | 7 |
| 4 | Function Description..... | 9 |
| 4.1 | Functional Block Descriptions..... | 9 |
| 4.2 | Interrupt Modes..... | 10 |
| 4.3 | SPI Slave Interface..... | 10 |
| 4.3.1 | 4-wire write operation..... | 11 |
| 4.3.2 | 4-wire read operation..... | 11 |
| 4.3.3 | 3-wire write operation..... | 12 |
| 4.3.4 | 3-wire read operation..... | 12 |
| 5 | Endpoint Buffer Management | 14 |
| 5.1 | Endpoint Buffer Management in Default Mode..... | 14 |
| 5.2 | Endpoint Buffer Management in Enhanced Mode | 15 |
| 6 | Commands and Registers | 17 |
| 6.1 | Command Summary..... | 17 |
| 6.2 | Initialization Commands..... | 22 |
| 6.2.1 | Set Address Enable..... | 22 |
| 6.2.2 | Set Endpoint Enable..... | 22 |
| 6.2.3 | Set Mode..... | 22 |
| 6.2.4 | Set Interrupt..... | 24 |
| 6.2.5 | Set Endpoint Configuration (for Enhanced Mode) | 24 |
| 6.3 | Data Flow Commands | 25 |
| 6.3.1 | Read Interrupt Register..... | 25 |
| 6.3.2 | Select Endpoint | 27 |
| 6.3.3 | Read Last Transaction Status | 27 |
| 6.3.4 | Read Endpoint Status..... | 28 |
| 6.3.5 | Read Buffer..... | 29 |
| 6.3.6 | Write Buffer | 29 |
| 6.3.7 | Clear Buffer | 29 |
| 6.3.8 | Validate Buffer | 29 |
| 6.3.9 | Set Endpoint Status | 30 |
| 6.3.10 | Acknowledge Setup | 30 |

| | | |
|------------|--|-----------|
| 6.4 | General Commands | 30 |
| 6.4.1 | Read Current Frame Number | 31 |
| 6.4.2 | Send Resume | 31 |
| 6.4.3 | Set 3-wire Mode | 31 |
| 6.4.4 | Read Vendor ID | 32 |
| 6.4.5 | Read Product ID | 32 |
| 6.4.6 | Read FTDI ID | 32 |
| 6.4.7 | Set IO Pad Drive Strength | 32 |
| 7 | Application Information | 33 |
| 8 | Devices Characteristics and Ratings | 34 |
| 8.1 | Absolute Maximum Ratings | 34 |
| 8.2 | DC Characteristics | 35 |
| 8.3 | AC Characteristics | 36 |
| 9 | Package Parameters | 38 |
| 9.1 | TSSOP-16 Package Dimensions | 38 |
| 9.2 | TSSOP-16 Package Markings | 39 |
| 9.3 | QFN-16 Package Dimensions | 40 |
| 9.4 | QFN-16 Package Markings | 41 |
| 9.5 | Solder Reflow Profile | 41 |
| 10 | Contact Information | 43 |
| | Appendix A – References | 44 |
| | Appendix B - List of Figures and Tables | 44 |
| | Appendix C - Revision History | 46 |

3 Device Pin Out and Signal Description

3.1 TSSOP-16 Package Pin Out

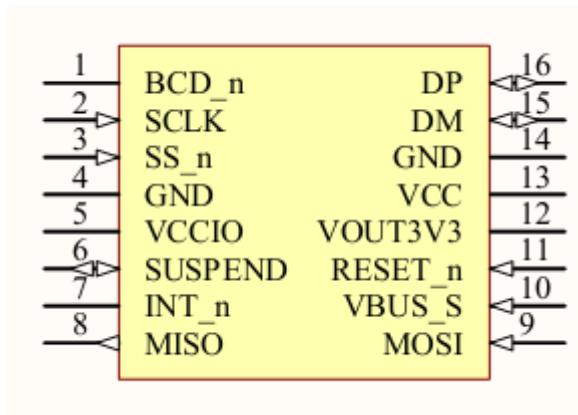

Figure 3-1 TSSOP-16 package schematic symbol

3.2 QFN-16 Package Pin Out

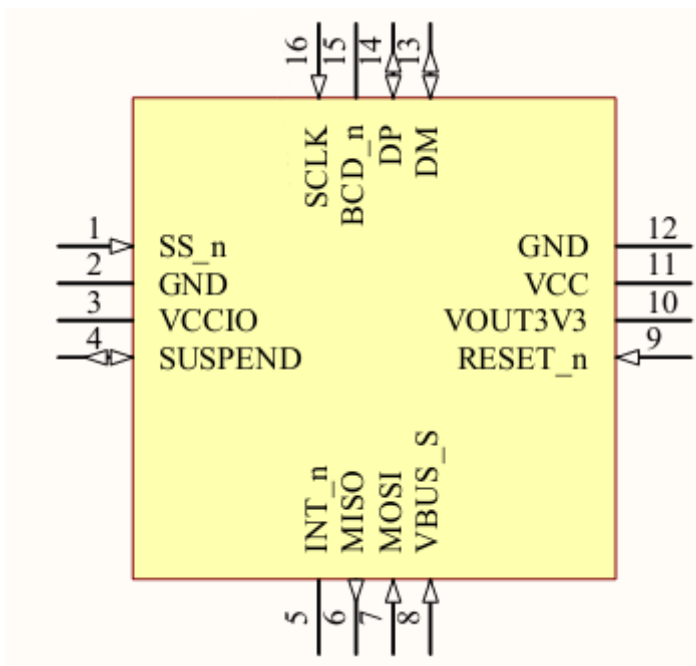

Figure 3-2 QFN-16 package schematic symbol

NOTE: Bottom Side centre pads not shown on QFN Pin Out:

- Ground Bottom View Location = Upper right
- VCCIO Bottom View Location = Lower right
- VOUT3V3 Bottom View Location = Lower left
- VCC Bottom View Location = Upper left

See QFN Package information in Section 9.3 below for more details. They may be left unconnected.

3.3 Pin Description

| PIN No. (TSSOP-16) | PIN No. (QFN-16) | PIN NAME | TYPE | DESCRIPTION |
|-----------------------|---------------------|----------|------|---|
| 1 | 15 | BCD_n | OD | USB Charger detector output |
| 2 | 16 | SCLK | I | SPI clock input |
| 3 | 1 | SS_n | I | SPI slave select input |
| 4 | 2 | GND | P | Ground |
| 5 | 3 | VCCIO | P | IO Supply Voltage; 1.8V, 2.5V or 3.3V |
| 6 | 4 | SUSPEND | I,OD | Device suspend (output) and wakeup (input) |
| 7 | 5 | INT_n | OD | Interrupt (Active Low) |
| 8 | 6 | MISO | O | 4-wire mode: SPI slave output 3-wire mode: no function. Leave it un-connected |
| 9 | 7 | MOSI | I/IO | 4-wire mode: SPI slave input 3-wire mode: SPI data input/output |
| 10 | 8 | VBUS_S | I | Vbus sensing input |
| 11 | 9 | RESET_n | I | Asynchronous reset (Active Low) |
| 12 | 10 | VOUT3V3 | P | 3.3V regulator output for 5V operation; To operate the IC at 3.3 V, supply 3.3 V to both the VCC and VOUT3V3 pins |
| 13 | 11 | VCC | P | Power supply (3.3V or 5V) |
| 14 | 12 | GND | P | Ground |
| 15 | 13 | DM | AIO | USB data signal minus |
| 16 | 14 | DP | AIO | USB data signal plus |
| | 17 | GND | P | Ground Center bottom pad – may be left unconnected |
| | 18 | VCCIO | P | IO Supply Voltage; 1.8V, 2.5V or 3.3V Center bottom pad – may be left unconnected |
| | 19 | VOUT3V3 | P | 3.3V regulator output for 5V operation; To operate the IC at 3.3 V, supply 3.3 V to both the VCC and VOUT3V3 pins Center bottom pad – may be left unconnected |
| | 20 | VCC | P | Power supply (3.3V or 5V) Center bottom pad – may be left unconnected |

Table 3.1 FT121 Pin Description

Note: a) Pin name with suffix “_n” denotes active low input/output signal.

b) Symbol used for pin TYPE:

OD : Open Drain Output

O : Output

IO : Bi-directional Input and Output

I : Plain input

AIO : Analog Input and Output

P : Power or ground

4 Function Description

The FT121 is a USB device controller which interfaces with microcontrollers via an SPI slave interface.

4.1 Functional Block Descriptions

The following sections describe the function of each block. Please refer to the block diagram shown in **Figure 2-1**.

+1.8V LDO Regulator. The +1.8V LDO regulator generates the +1.8V reference voltage for the internal core of the IC with input capabilities from 3.3V or 5V.

+3.3V LDO Regulator. The +3.3V LDO regulator generates the +3.3V supply voltage for the USB transceiver. An external decoupling capacitor needs to be attached to the VOUT3V3 regulator output pin. The regulator also provides +3.3V power to the 1.5k Ω internal pull up resistor on DP pin. The allowable input voltages are 5V or 3.3V. When using 3.3V as the input voltage, the VCC and VOUT3V3 pins should be tied together. This will result in the regulator being by-passed.

USB Transceiver. The USB Transceiver cell provides the USB 1.1 / USB 2.0 full-speed physical interface. Output drivers provide +3.3V level slew rate control, while a differential input and two single ended input receivers provide data in, Single-Ended-0 (SE0) and USB reset detection conditions respectfully. A 1.5k Ω pull up resistor on DP is incorporated.

DPLL. The DPLL cell locks on to the incoming NRZI USB data and generates recovered clock and data signals.

Internal Oscillator. The Internal Oscillator cell generates a reference clock. This provides an input to the Clock Multiplier function.

Clock Multiplier. The 12MHz and 48MHz reference clock signals for various internal blocks can be generated from the reference clock via the oscillator functions and clock multiplier circuitry.

Serial Interface Engine (SIE). The Serial Interface Engine (SIE) block performs the parallel to serial and serial to parallel conversion of the USB data. In accordance with the USB 2.0 specification, it performs bit stuffing/un-stuffing and CRC5/CRC16 generation. It also checks the CRC on the USB data stream.

USB Protocol Engine. The USB Protocol Engine manages the data stream from the device USB control endpoint. It handles the low level USB protocol requests generated by the USB host controller. The Protocol Engine also includes a memory management unit which handles endpoint buffers.

OUT Buffer. Data sent from the USB host controller to FT121 via the USB data OUT endpoint is stored in the OUT buffer. Data is removed from the OUT buffer to system memory under control of the parallel interface block.

IN Buffer. Data from system memory is stored in the IN buffer. The USB host controller removes data from the IN buffer by sending a USB request for data from the device data IN endpoint.

RESET Generator. The integrated Reset Generator cell provides a reliable power-on reset to the device internal circuitry at power up. The RESET_n input pin allows an external device to reset the FT121.

SPI Controller Block. The SPI slave controller provides control and data interfaces between the external MCU and internal registers and endpoint buffers. It supports 4-wire (default) or 3-wire SPI operation.

4.2 Interrupt Modes

The FT121 interrupt pin (INT_n) can be programmed to generate an interrupt in different modes. The interrupt source can be any bit in the Interrupt Register, an SOF packet being received, or both. The interrupt modes are selectable by two register bits, one is the SOF-only Interrupt Mode bit (bit 7 of Clock Division Factor register), and the other is the Interrupt Pin Mode bit (bit 5 of Interrupt Configuration register).

| Interrupt mode | Bit SOF-only Interrupt Mode | Bit Interrupt Pin Mode | Interrupt source |
|----------------|-----------------------------|------------------------|---------------------------------------|
| 0 | 0 | 0 | Any bit in Interrupt register |
| 1 | 0 | 1 | Any bit in Interrupt register and SOF |
| 2 | 1 | X | SOF only |

Table 4.1 Interrupt modes

4.3 SPI Slave Interface

The SPI slave interface supports 4-wire (default) and 3-wire operation. In 4-wire operation the SPI master will drive data on the MOSI pin and the SPI slave will drive data on the MISO pin. In 3-wire operation both SPI master and SPI slave share the same data pin (MOSI pin becomes a bi-directional pin). Upon power-on or hardware reset, the FT121 SPI slave interface is in 4-wire mode. The 3-wire operation is enabled when a Set 3-wire command is issued to the FT121.

The SPI protocol will follow a command + data format where a command is transmitted after SS_n is asserted and each subsequent byte will be a data byte. When all data bytes for this command are completed the SS_n is de-asserted. This can be seen in Figure 4-1.

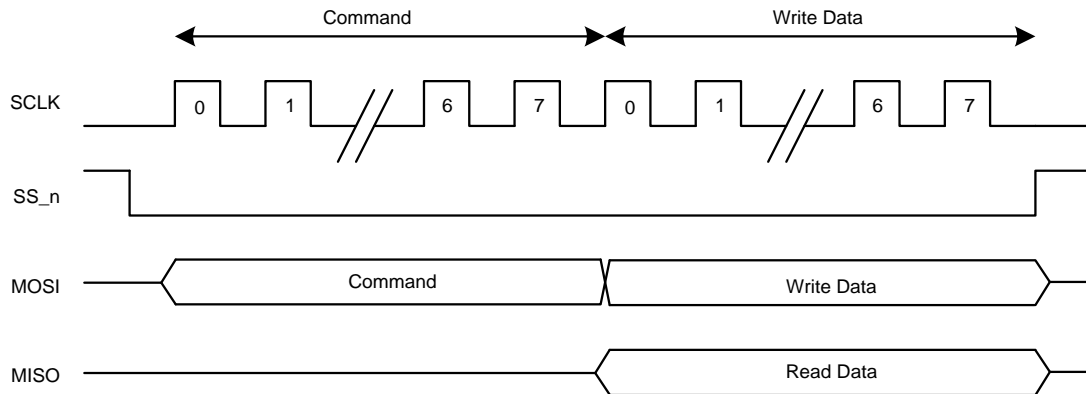

Figure 4-1 SPI access

The SPI slave supports SPI mode 1 (CPOL=0, CPHA=1). This means the rising edge is the driving edge while the falling edge is the sample edge. The drive edge is always before the sample edge.

The maximum SPI clock supported is 20MHz, for both 4-wire and 3-wire modes. Refer to the AC characteristics section for SPI timing figures.

4.3.1 4-wire write operation

When the SPI master performs a data write operation, it drives the SS_n line low, sends the 8-bit command byte on MOSI line, followed by sending of the data bytes. The length of the data byte ranges from 0 to maximum 506, depending on the command type. The master will signal the end of the data write operation by drive the SS_n line high.

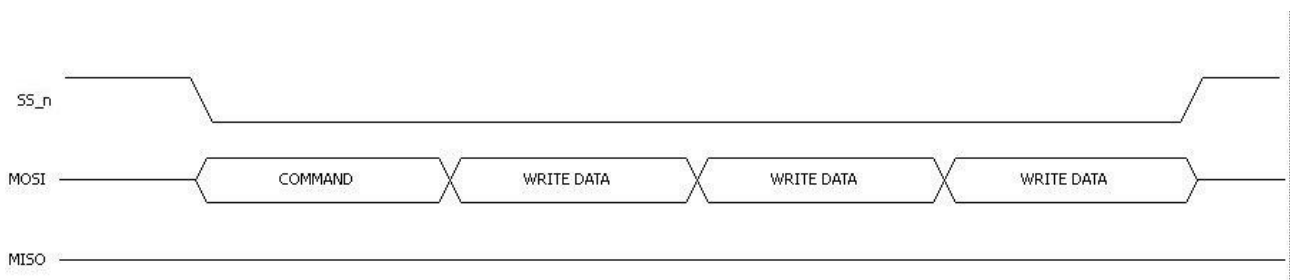

Figure 4-2 4-wire write operation

4.3.2 4-wire read operation

When the SPI master performs a data read operation, it drives the SS_n line low and sends the 8-bit command byte on MOSI line. The FT121 will output data bytes on the MISO line. The length of the data byte ranges from 0 to maximum 506, depending on the command type. The master will signal the end of the data read operation by drive the SS_n line high.

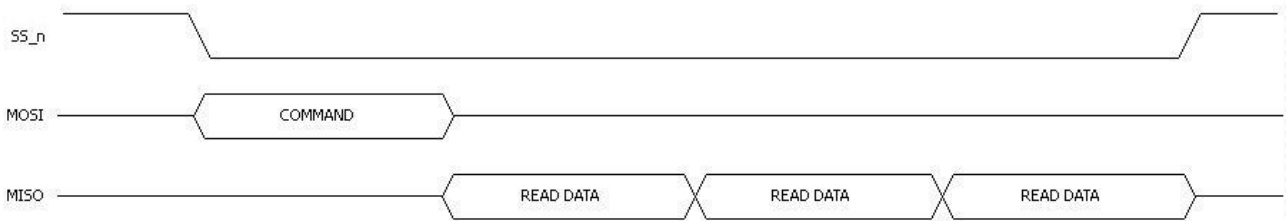

Figure 4-3 4-wire read operation

4.3.3 3-wire write operation

When the SPI master performs a data write operation, it drives the SS_n line low, sends the 8-bit command byte on MOSI line, followed by sending the data bytes. The length of the data byte ranges from 0 to maximum 506, depending on the command type. The master will signal the end of the data write operation by drive the SS_n line high.

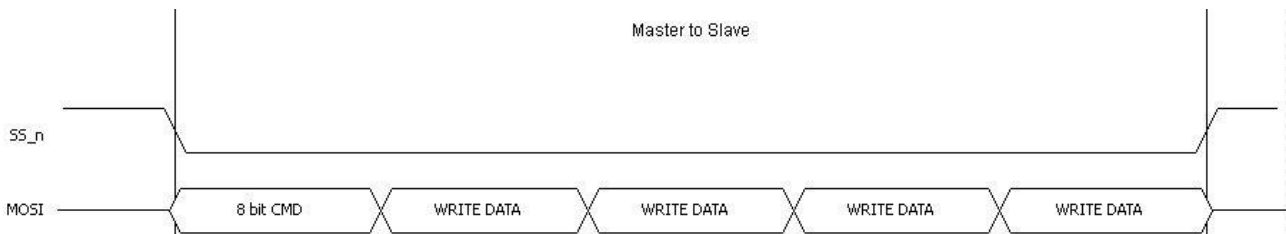

Figure 4-4 3-wire write operation

4.3.4 3-wire read operation

When the SPI master performs a data read operation, it drives the SS_n line low and sends the 8-bit command byte on MOSI line. The master will stop driving the MOSI line. The FT121 will output data bytes on the MOSI line. The length of the data byte ranges from 0 to maximum 506, depending on the command type. The master will signal the end of the data read operation by drive the SS_n line high.

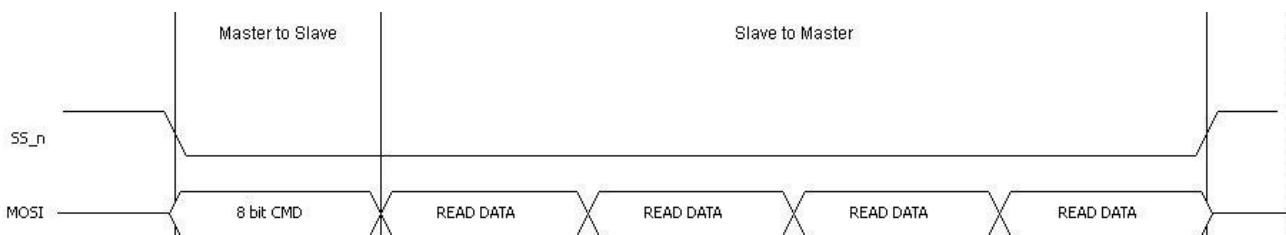

Figure 4-5 3-wire read operation

It is important that bus contention should be avoided during the bus turnaround period – i.e. moving from the command byte to a read byte. In this instance the master will stop driving at the same clock edge (rising edge) as the slave starts to drive. To avoid bus contention the FT121 will implement delays so that it only starts to drive the MOSI line at least 5ns after the SCLK driving edge – this will give the master a minimum of 5ns to stop driving MOSI, which should ensure no bus contentions. At this bus turnaround point it's also more natural for a clash not to occur, as the master is the source of the clock, so will drive the clock and MOSI off at similar times. For the slave to drive MOSI it has to pass the clock

through the I/O buffers, into the internal circuits, clock MOSI and then get MOSI out through the output buffers. This long path in and out of the slave will have an inherent delay of a few nanoseconds.

5 Endpoint Buffer Management

The FT121 has 2 modes of operation for command and memory management: the default mode and the enhanced mode. The buffer management schemes are different in these two modes. Upon reset the default mode is functional. The enhanced mode is activated when any of the Set Endpoint Configuration commands (B0h – BFh) are received.

5.1 Endpoint Buffer Management in Default Mode

In default mode the FT121 has 3 bi-directional endpoints (EP0, EP1 and EP2). EP0 is the control endpoint, with 16 bytes maximum packet size for both the control OUT and control IN endpoints. EP1 can be used as either a bulk endpoint or an interrupt endpoint, with 16 bytes maximum packet size for both OUT and IN endpoints. Table 5.1 shows the endpoint type and maximum packet size for EP0 and EP1.

| Endpoint Number (EP) | Endpoint Index (EPI) | Endpoint Direction | Transfer Type | Max Packet Size |
|----------------------|----------------------|--------------------|----------------|-----------------|
| 0 | 0 | OUT | Control | 16 |
| | 1 | IN | Control | 16 |
| 1 | 2 | OUT | Bulk/Interrupt | 16 |
| | 3 | IN | Bulk/Interrupt | 16 |

Table 5.1 Endpoint configuration for EP0 and EP1

EP2 is the primary endpoint. It can be configured as either a bulk/interrupt or isochronous endpoint. The maximum packet size allowed for EP2 depends on the mode of configuration through the Set Mode command. Table 5.2 shows all the 4 endpoint configuration modes for EP2.

| EP2 Endpoint Configuration Mode | Endpoint Index (EPI) | Endpoint Direction | Transfer Type | Max Packet Size |
|---------------------------------|----------------------|--------------------|----------------|-----------------|
| 0 (default) | 4 | OUT | Bulk/Interrupt | 64 |
| | 5 | IN | Bulk/Interrupt | 64 |
| 1 | 4 | OUT | Isochronous | 128 |
| 2 | 5 | IN | Isochronous | 128 |
| 3 | 4 | OUT | Isochronous | 64 |
| | 5 | IN | Isochronous | 64 |

Table 5.2 Endpoint configuration for EP2

As the primary endpoint, EP2 is suitable for transmitting or receiving relatively large data. To improve the data throughput, EP2 is implemented with double buffering. This allows the concurrent operation between USB bus access and MCU local bus access. For example, for EP2 IN endpoint (EPI5), the USB host can read data from FT121 Buffer 0 while the local MCU is writing to Buffer 1 at the same time. The USB host can subsequently read from the FT121 Buffer 1 without waiting for it to be filled. Buffer switching is handled automatically by FT121.

5.2 Endpoint Buffer Management in Enhanced Mode

In enhanced mode the FT121 supports a dedicated 1kB buffer for IN packets and a dedicated 1kB buffer for OUT packets. The OUT/IN buffer can be allocated to any endpoint with the same direction, up to a maximum of 504 bytes double buffered (1008 bytes in total) to one endpoint. 504 is the maximum byte count as there are 1024 bytes in total per OUT/IN Buffer and 8 bytes for IN and OUT packets on control endpoint 0 must always be reserved. Control, interrupt and bulk endpoints can have a maximum packet size of 64 bytes and only isochronous endpoints can be allocated more than 64 bytes.

Isochronous modes can have larger buffer sizes as USB packets can be larger than 64 bytes for isochronous transfer. Isochronous buffers are managed in the same way as bulk, interrupt and control buffers – i.e. a buffer is for one USB packet only and will not span more than one USB packet.

An example of buffer configurations follows, where Configuration 1 and 2 have larger isochronous buffers.

| | Configuration 0 | | Configuration 1 | | Configuration 2 | |
|-------------------------------------|-----------------|--------|-----------------|--------|-----------------|--------|
| | EP | Buffer | EP | Buffer | EP | Buffer |
| Each cell indicates a 64 byte block | 7 | 1 | 7 | 1 | 5 (ISO) | 1 |
| | 7 | 0 | (ISO) | | | |
| | 6 | 1 | 7 | 0 | | |
| | 6 | 0 | (ISO) | | | |
| | 5 | 1 | 6 | 1 | | |
| | 5 | 0 | 6 | 0 | | |
| | 4 | 1 | 2 | 1 | | |
| | 4 | 0 | 2 | 0 | | |
| | 3 | 1 | 1 (ISO) | 1 | 5 (ISO) | 0 |
| | 3 | 0 | | | | |
| | 2 | 1 | 1 (ISO) | 0 | | |
| | 2 | 0 | | | | |
| | 1 | 1 | | | | |
| | 1 | 0 | | | | |
| | 0 | 1 | 0 | 1 | 0 | 1 |
| | 0 | 0 | 0 | 0 | 0 | 0 |

Table 5.3 Example buffer configuration

The endpoint buffer configurations, settable using the Set Endpoint Configuration command, are as follows:

| Endpoint buffer size register setting (0b') | Non-isochronous endpoint | Isochronous endpoint |
|---|--------------------------|----------------------|
| 0000 | 8 bytes | 16 bytes |
| 0001 | 16 bytes | 32 bytes |
| 0010 | 32 bytes | 48 bytes |
| 0011 | 64 bytes | 64 bytes |
| 0100 | - | 96 bytes |
| 0101 | - | 128 bytes |
| 0110 | - | 160 bytes |
| 0111 | - | 192 bytes |
| 1000 | - | 256 bytes |
| 1001 | - | 320 bytes |
| 1010 | - | 384 bytes |
| 1011 | - | 504 bytes |
| 1100-1111 | - | - |

Table 5.4 Endpoint Maximum Packet Size

Note: 504 is the maximum byte count as there are 1024 bytes in total and 8 bytes IN and OUT packets for control endpoint 0 must always be reserved.

6 Commands and Registers

The FT121 supports two command sets: a default command set (Table 6.1) and an enhanced command set (Table 6.2). The enhanced command set is activated if any of the Set Endpoint Configuration commands (0xB0-0xBF) are received by the FT121. Otherwise, the default command set shall be valid.

6.1 Command Summary

| Command Name | Target | Code (hex) | Data phase |
|--------------------------------|----------------|------------|------------------------|
| Initialization Commands | | | |
| Set Address Enable | Device | D0h | Write 1 byte |
| Set Endpoint Enable | Device | D8h | Write 1 byte |
| Set Mode | Device | F3h | Write 2 bytes |
| Set Interrupt | Device | FBh | Write 1 byte |
| Data Flow Commands | | | |
| Read Interrupt Register | Device | F4h | Read 2 bytes |
| Select Endpoint | Endpoint 0 OUT | 00h | Read 1 byte (optional) |
| | Endpoint 0 IN | 01h | Read 1 byte (optional) |
| | Endpoint 1 OUT | 02h | Read 1 byte (optional) |
| | Endpoint 1 IN | 03h | Read 1 byte (optional) |
| | Endpoint 2 OUT | 04h | Read 1 byte (optional) |
| | Endpoint 2 IN | 05h | Read 1 byte (optional) |
| Read Last Transaction Status | Endpoint 0 OUT | 40h | Read 1 byte |
| | Endpoint 0 IN | 41h | Read 1 byte |
| | Endpoint 1 OUT | 42h | Read 1 byte |
| | Endpoint 1 IN | 43h | Read 1 byte |
| | Endpoint 2 OUT | 44h | Read 1 byte |
| | Endpoint 2 IN | 45h | Read 1 byte |
| Read Endpoint Status | Endpoint 0 OUT | 80h | Read 1 byte |
| | Endpoint 0 IN | 81h | Read 1 byte |
| | Endpoint 1 OUT | 82h | Read 1 byte |
| | Endpoint 1 IN | 83h | Read 1 byte |
| | Endpoint 2 OUT | 84h | Read 1 byte |

| Command Name | Target | Code (hex) | Data phase |
|---------------------------|-------------------|------------|----------------------|
| | Endpoint 2 IN | 85h | Read 1 byte |
| Read Buffer | Selected Endpoint | E0h | Read multiple bytes |
| Write Buffer | Selected Endpoint | F0h | Write multiple bytes |
| Set Endpoint Status | Endpoint 0 OUT | 50h | Write 1 byte |
| | Endpoint 0 IN | 51h | Write 1 byte |
| | Endpoint 1 OUT | 52h | Write 1 byte |
| | Endpoint 1 IN | 53h | Write 1 byte |
| | Endpoint 2 OUT | 54h | Write 1 byte |
| | Endpoint 2 IN | 55h | Write 1 byte |
| Acknowledge Setup | Selected Endpoint | F1h | None |
| Clear Buffer | Selected Endpoint | F2h | None |
| Validate Buffer | Selected Endpoint | FAh | None |
| General Commands | | | |
| Read Current Frame Number | Device | F5h | Read 1 or 2 bytes |
| Send Resume | Device | F6h | None |

Table 6.1 FT121 default command set

| Command Name | Target | Code (hex) | Data phase |
|--------------------------------|----------------|------------|---------------|
| Initialization Commands | | | |
| Set Address Enable | Device | D0h | Write 1 byte |
| Set Endpoint Enable | Device | D8h | Write 1 byte |
| Set Mode | Device | F3h | Write 2 bytes |
| Set Interrupt | Device | FBh | Write 1 byte |
| Set Endpoint Configuration | Endpoint 0 OUT | B0h | Write 1 byte |
| | Endpoint 0 IN | B1h | Write 1 byte |
| | Endpoint 1 OUT | B2h | Write 1 byte |
| | Endpoint 1 IN | B3h | Write 1 byte |
| | Endpoint 2 OUT | B4h | Write 1 byte |
| | Endpoint 2 IN | B5h | Write 1 byte |

| Command Name | Target | Code (hex) | Data phase |
|------------------------------|----------------|------------------------|------------------------|
| | Endpoint 3 OUT | B6h | Write 1 byte |
| | Endpoint 3 IN | B7h | Write 1 byte |
| | Endpoint 4 OUT | B8h | Write 1 byte |
| | Endpoint 4 IN | B9h | Write 1 byte |
| | Endpoint 5 OUT | BAh | Write 1 byte |
| | Endpoint 5 IN | BBh | Write 1 byte |
| | Endpoint 6 OUT | BCh | Write 1 byte |
| | Endpoint 6 IN | BDh | Write 1 byte |
| | Endpoint 7 OUT | BEh | Write 1 byte |
| Endpoint 7 IN | BFh | Write 1 byte | |
| Data Flow Commands | | | |
| Read Interrupt Register | Device | F4h | Read 1 to 4 bytes |
| Select Endpoint | Endpoint 0 OUT | 00h | Read 1 byte (optional) |
| | Endpoint 0 IN | 01h | Read 1 byte (optional) |
| | Endpoint 1 OUT | 02h | Read 1 byte (optional) |
| | Endpoint 1 IN | 03h | Read 1 byte (optional) |
| | Endpoint 2 OUT | 04h | Read 1 byte (optional) |
| | Endpoint 2 IN | 05h | Read 1 byte (optional) |
| | Endpoint 3 OUT | 06h | Read 1 byte (optional) |
| | Endpoint 3 IN | 07h | Read 1 byte (optional) |
| | Endpoint 4 OUT | 08h | Read 1 byte (optional) |
| | Endpoint 4 IN | 09h | Read 1 byte (optional) |
| | Endpoint 5 OUT | 0Ah | Read 1 byte (optional) |
| | Endpoint 5 IN | 0Bh | Read 1 byte (optional) |
| | Endpoint 6 OUT | 0Ch | Read 1 byte (optional) |
| | Endpoint 6 IN | 0Dh | Read 1 byte (optional) |
| Endpoint 7 OUT | 0Eh | Read 1 byte (optional) | |
| Endpoint 7 IN | 0Fh | Read 1 byte (optional) | |
| Read Last Transaction Status | Endpoint 0 OUT | 40h | Read 1 byte |

| Command Name | Target | Code (hex) | Data phase |
|----------------------|----------------|-------------|-------------|
| | Endpoint 0 IN | 41h | Read 1 byte |
| | Endpoint 1 OUT | 42h | Read 1 byte |
| | Endpoint 1 IN | 43h | Read 1 byte |
| | Endpoint 2 OUT | 44h | Read 1 byte |
| | Endpoint 2 IN | 45h | Read 1 byte |
| | Endpoint 3 OUT | 46h | Read 1 byte |
| | Endpoint 3 IN | 47h | Read 1 byte |
| | Endpoint 4 OUT | 48h | Read 1 byte |
| | Endpoint 4 IN | 49h | Read 1 byte |
| | Endpoint 5 OUT | 4Ah | Read 1 byte |
| | Endpoint 5 IN | 4Bh | Read 1 byte |
| | Endpoint 6 OUT | 4Ch | Read 1 byte |
| | Endpoint 6 IN | 4Dh | Read 1 byte |
| | Endpoint 7 OUT | 4Eh | Read 1 byte |
| | Endpoint 7 IN | 4Fh | Read 1 byte |
| Read Endpoint Status | Endpoint 0 OUT | 80h | Read 1 byte |
| | Endpoint 0 IN | 81h | Read 1 byte |
| | Endpoint 1 OUT | 82h | Read 1 byte |
| | Endpoint 1 IN | 83h | Read 1 byte |
| | Endpoint 2 OUT | 84h | Read 1 byte |
| | Endpoint 2 IN | 85h | Read 1 byte |
| | Endpoint 3 OUT | 86h | Read 1 byte |
| | Endpoint 3 IN | 87h | Read 1 byte |
| | Endpoint 4 OUT | 88h | Read 1 byte |
| | Endpoint 4 IN | 89h | Read 1 byte |
| | Endpoint 5 OUT | 8Ah | Read 1 byte |
| | Endpoint 5 IN | 8Bh | Read 1 byte |
| | Endpoint 6 OUT | 8Ch | Read 1 byte |
| Endpoint 6 IN | 8Dh | Read 1 byte | |

| Command Name | Target | Code (hex) | Data phase |
|---------------------------|-------------------|------------|----------------------|
| | Endpoint 7 OUT | 8Eh | Read 1 byte |
| | Endpoint 7 IN | 8Fh | Read 1 byte |
| Read Buffer | Selected Endpoint | E0h | Read multiple bytes |
| Write Buffer | Selected Endpoint | F0h | Write multiple bytes |
| Set Endpoint Status | Endpoint 0 OUT | 50h | Write 1 byte |
| | Endpoint 0 IN | 51h | Write 1 byte |
| | Endpoint 1 OUT | 52h | Write 1 byte |
| | Endpoint 1 IN | 53h | Write 1 byte |
| | Endpoint 2 OUT | 54h | Write 1 byte |
| | Endpoint 2 IN | 55h | Write 1 byte |
| | Endpoint 3 OUT | 56h | Write 1 byte |
| | Endpoint 3 IN | 57h | Write 1 byte |
| | Endpoint 4 OUT | 58h | Write 1 byte |
| | Endpoint 4 IN | 59h | Write 1 byte |
| | Endpoint 5 OUT | 5Ah | Write 1 byte |
| | Endpoint 5 IN | 5Bh | Write 1 byte |
| | Endpoint 6 OUT | 5Ch | Write 1 byte |
| | Endpoint 6 IN | 5Dh | Write 1 byte |
| | Endpoint 7 OUT | 5Eh | Write 1 byte |
| | Endpoint 7 IN | 5Fh | Write 1 byte |
| Acknowledge Setup | Selected Endpoint | F1h | None |
| Clear Buffer | Selected Endpoint | F2h | None |
| Validate Buffer | Selected Endpoint | FAh | None |
| General Commands | | | |
| Send Resume | Device | F6h | None |
| Read Current Frame Number | Device | F5h | Read 1 or 2 bytes |
| Set 3-wire Mode | Device | E8h | None |
| Set IO Pad Drive Strength | Device | E9h | Write 1 byte |

| Command Name | Target | Code (hex) | Data phase |
|-----------------|--------|------------|--------------|
| Read Vendor ID | Device | EBh | Read 2 bytes |
| Read Product ID | Device | EAh | Read 2 bytes |
| Read FTDI ID | Device | EDh | Read 1 byte |

Table 6.2 enhanced command set

6.2 Initialization Commands

6.2.1 Set Address Enable

Command : D0h

Data : Write 1 byte

| Bit | Symbol | Reset | Description |
|-----|---------|------------|---|
| 6-0 | Address | 0b'0000000 | USB assigned device address. A bus reset will reset all address bits to 0. |
| 7 | Enable | 0 | Function enable. A bus reset will automatically enable the function at default address 0. |

Table 6.3 Address Enable Register

6.2.2 Set Endpoint Enable

Command : D8h

Data : Write 1 byte

| Bit | Symbol | Reset | Description |
|-----|-----------|------------|--|
| 0 | EP_Enable | 0 | Enable all endpoints (Note EP0 is always enabled regardless the setting of EP_Enable bit). Endpoints can only be enabled when the function is enabled. |
| 7-1 | Reserved | 0b'0000000 | Reserved, write to 0 |

Table 6.4 Endpoint Enable Register

6.2.3 Set Mode

Command : F3h

Data : Write 2 bytes

| Bit | Symbol | Reset | Description |
|-----|----------|-------|----------------------|
| 1-0 | Reserved | 0b'00 | Reserved, write to 0 |

| Bit | Symbol | Reset | Description |
|-----|-----------------------------|-------|---|
| 2 | Clock Running | 1 | 0: internal clocks stop during USB suspend 1: internal clocks continue running during USB suspend This bit must be set to '0' for bus powered application in order to meet the USB suspend current requirement. Note: The programmed value will not be changed by a bus reset. |
| 3 | Interrupt Mode | 1 | 0: interrupt will not generate on NAK or Error transactions 1: interrupt will generate on NAK and Error transactions Note: The programmed value will not be changed by a bus reset. |
| 4 | DP_Pullup | 0 | 0: Pullup resistor on DP pin disabled 1: Pullup resistor on DP pin enabled when Vbus is present Note: The programmed value will not be changed by a bus reset. |
| 5 | Reserved | 0 | Reserved, write to 0 |
| 7-6 | Endpoint Configuration Mode | 0b'00 | Set the endpoint configuration mode for EP2. 00: Mode 0 (Non-ISO Mode) 01: Mode 1 (ISO-OUT Mode) 10: Mode 2 (ISO-IN Mode) 11: Mode 3 (ISO-IO Mode) In Enhanced Mode, these 2 bits are reserved. The Endpoint Configuration will be done through separate command. See "Set Endpoint Configuration" commands. |

Table 6.5 Configuration Register (Byte 1)

| Bit | Symbol | Reset | Description |
|-----|-------------------------|---------|--|
| 3-0 | Reserved | 0b'1011 | Reserved, write to 0b'1111 |
| 5-4 | Reserved | 0b'00 | Reserved, write to 0 |
| 6 | SET_TO_ONE | 0 | This bit must be set to 1 |
| 7 | SOF-only Interrupt Mode | 0 | 0: normal operation 1: interrupt will generate on receiving SOF packet only, regardless of the value of the Interrupt Pin Mode bit in the Interrupt configuration register. |

Table 6.6 Configuration Register (Byte 2)

6.2.4 Set Interrupt

Command : FBh

Data : Write 1 byte

| Bit | Symbol | Reset | Description |
|-----|-----------------------|----------|---|
| 4-0 | Reserved | 0b'00000 | Reserved, write to 0b'00000 |
| 5 | Interrupt Pin Mode | 0 | 0: normal operation. Interrupt will generate if any bit in the interrupt register is set. 1: interrupt will generate upon receiving a SOF packet or if any bit in the interrupt register is set. |
| 6 | EPI4 Interrupt Enable | 0 | Interrupt Enable for endpoint index 4. For enhanced mode this bit has no function. EPI4 interrupt is always enabled. |
| 7 | EPI5 Interrupt Enable | 0 | Interrupt Enable for endpoint index 5. For enhanced mode this bit has no function. EPI5 interrupt is always enabled |

Table 6.7 Interrupt Configuration Register

6.2.5 Set Endpoint Configuration (for Enhanced Mode)

Command : B0-BFh

Data : Write 1 byte

| Bit | Symbol | Reset | Description |
|-----|------------------|---------|--|
| 0 | Endpoint Enabled | 0 | Enable or disable the endpoint index associated with the command |
| 2-1 | Endpoint Type | 0b'00 | Endpoint type 00: control 01: bulk or interrupt 10: isochronous 11: reserved |
| 6-3 | Max Packet Size | 0b'0000 | Maximum USB packet size for this endpoint. Defines the IN buffer or OUT buffer size for the endpoint. Refer to Table 5.4 for full details on the buffer configuration. |
| 7 | Reserved | 0 | Reserved, write to 0 |

Table 6.8 Endpoint Configuration Register

6.3 Data Flow Commands

6.3.1 Read Interrupt Register

Command : F4h

Data : Read 1 or 2 bytes (Default Mode); Read 1-4 bytes (Enhanced Mode)

| Bit | Symbol | Reset | Description |
|-----|----------------|-------|--|
| 0 | Endpoint 0 Out | 0 | Interrupt for endpoint 0 OUT buffer. Cleared by Read Last Transaction Status command. |
| 1 | Endpoint 0 In | 0 | Interrupt for endpoint 0 IN buffer. Cleared by Read Last Transaction Status command. |
| 2 | Endpoint 1 Out | 0 | Interrupt for endpoint 1 OUT buffer. Cleared by Read Last Transaction Status command. |
| 3 | Endpoint 1 In | 0 | Interrupt for endpoint 1 IN buffer. Cleared by Read Last Transaction Status command. |
| 4 | Endpoint 2 Out | 0 | Interrupt for endpoint 2 OUT buffer. Cleared by Read Last Transaction Status command. |
| 5 | Endpoint 2 In | 0 | Interrupt for endpoint 2 IN buffer. Cleared by Read Last Transaction Status command. |
| 6 | Bus Reset | 0 | Interrupt for bus reset. This bit will be cleared after reading. |
| 7 | Suspend Change | 0 | Interrupt for USB bus suspend status change. This bit will be set to '1' when FT121 goes to suspend (missing 3 continuous SOFs) or resumes from suspend. This bit will be cleared after reading. |

Table 6.9 Interrupt Register Byte 1

| Bit | Symbol | Reset | Description |
|-----|----------|-------|-------------|
| 7-0 | Reserved | 00h | Reserved |

Table 6.10 Interrupt Register Byte 2

| Bit | Symbol | Reset | Description |
|-----|----------------|-------|---|
| 0 | Endpoint 3 Out | 0 | Interrupt for endpoint 3 OUT buffer. Cleared by Read Last Transaction Status command. |
| 1 | Endpoint 3 In | 0 | Interrupt for endpoint 3 IN buffer. Cleared by Read Last Transaction Status command. |
| 2 | Endpoint 4 Out | 0 | Interrupt for endpoint 4 OUT buffer. Cleared by Read Last Transaction Status command. |
| 3 | Endpoint 4 In | 0 | Interrupt for endpoint 4 IN buffer. Cleared by Read Last Transaction Status command. |

| Bit | Symbol | Reset | Description |
|-----|----------------|-------|---|
| 4 | Endpoint 5 Out | 0 | Interrupt for endpoint 5 OUT buffer. Cleared by Read Last Transaction Status command. |
| 5 | Endpoint 5 In | 0 | Interrupt for endpoint 5 IN buffer. Cleared by Read Last Transaction Status command. |
| 6 | Endpoint 6 Out | 0 | Interrupt for endpoint 6OUT buffer. Cleared by Read Last Transaction Status command. |
| 7 | Endpoint 6 In | 0 | Interrupt for endpoint 6 IN buffer. Cleared by Read Last Transaction Status command. |

Table 6.11 Interrupt Register Byte 3 (for Enhanced Mode)

| Bit | Symbol | Reset | Description |
|-----|----------------|-----------|---|
| 0 | Endpoint 7 Out | 0 | Interrupt for endpoint 7 OUT buffer. Cleared by Read Last Transaction Status command. |
| 1 | Endpoint 7 In | 0 | Interrupt for endpoint 7 IN buffer. Cleared by Read Last Transaction Status command. |
| 7-2 | Reserved | 0b'xxxxxx | Reserved |

Table 6.12 Interrupt Register Byte 4 (for Enhanced Mode)

6.3.2 Select Endpoint

Command : 00-05h (00-0Fh for Enhanced Mode)

Data : Read 1 byte

| Bit | Symbol | Reset | Description |
|-----|------------|-----------|--|
| 0 | Full/Empty | 0 | 0: selected endpoint buffer is empty 1: selected endpoint buffer is not empty |
| 1 | Stall | 0 | 0: selected endpoint is not stalled 1: selected endpoint is stalled |
| 7-2 | Reserved | 0b'xxxxxx | Reserved |

Table 6.13 Endpoint Status Register

6.3.3 Read Last Transaction Status

Command : 40-45h (40-4Fh for Enhanced Mode)

Data : Read 1 byte

| Bit | Symbol | Reset | Description |
|-----|-------------------------------|---------|--|
| 0 | Data Receive/Transmit Success | 0 | 0: indicate USB data receive or transmit not OK 1: indicate USB data receive or transmit OK |
| 4-1 | Error Code | 0b'0000 | Refer to Table 6.15 |
| 5 | Setup Packet | 0 | 0: indicate not a setup packet 1: indicate last received packet has a SETUP token |
| 6 | Data 0/1 Packet | 0 | 0: packet has a DATA0 token 1: packet has a DATA1 token |
| 7 | Previous Status not Read | 0 | 0: previous transaction status was read 1: previous transaction status was not read |

Table 6.14 Endpoint Last Transaction Status Register

| Error Code | Result |
|------------|--------------------|
| 0000 | No error |
| 0001 | PID encoding error |

| Error Code | Result |
|------------|-------------------|
| 0010 | PID unknown |
| 0011 | Unexpected packet |
| 0100 | Token CRC error |
| 0101 | Data CRC error |
| 0110 | Time out error |
| 0111 | Reserved |
| 1000 | Unexpected EOP |
| 1001 | Packet NAKed |
| 1010 | Sent stall |
| 1011 | Buffer overflow |
| 1101 | Bit stuff error |
| 1111 | Wrong DATA PID |

Table 6.15 Transaction error code

6.3.4 Read Endpoint Status

Command : 80-85h (80-8Fh for Enhanced Mode)

Data : Read 1 byte

| Bit | Symbol | Reset | Description |
|-----|---------------|-------|--|
| 1-0 | Reserved | 0b'00 | Reserved |
| 2 | Setup packet | 0 | 0: indicate not a setup packet 1: indicate last received packet has a SETUP token |
| 4-3 | Reserved | 0b'xx | Reserved |
| 5 | Buffer 0 Full | 0 | 0: buffer 0 is not filled up 1: buffer 0 is filled up |
| 6 | Buffer 1 Full | 0 | 0: buffer 1 is not filled up 1: buffer 1 is filled up |

| Bit | Symbol | Reset | Description |
|-----|------------------|-------|--|
| 7 | Endpoint Stalled | 0 | 0: endpoint is not stalled 1: endpoint is stalled |

Table 6.16 Endpoint Buffer Status Register

6.3.5 Read Buffer

Command : E0h

Data : Read multiple bytes

The Read Buffer command is used to read the received packet from the selected endpoint OUT buffer.

The data in the endpoint buffer is organized as follows:

byte 0: length of payload packet, MSB(for default mode this byte is ignored)

byte 1: length of payload packet, LSB

byte 2: Payload packet byte 1

byte 3: Payload packet byte 2

...

byte n+1: Payload packet byte n (n = packet length)

6.3.6 Write Buffer

Command : F0h

Data : Write multiple bytes

The Write Buffer command is used to write payload packet to the selected endpoint IN buffer.

The data must be organized in the same way as described in the Read Buffer command. For default mode byte 0 should always be set to 00h.

6.3.7 Clear Buffer

Command : F2h

Data : None

The Clear Buffer command should be issued after all data has been read out from the endpoint buffer. This is to free the buffer to receive next packet from USB host.

6.3.8 Validate Buffer

Command : FAh

Data : None

The Validate Buffer command should be issued after all data has been written to the endpoint buffer. This is to set the buffer full flag so that the packet can be sent to USB host when IN token arrives.

6.3.9 Set Endpoint Status

Command : 50-55h (50-5Fh for Enhanced Mode)

Data : Write 1 byte

| Bit | Symbol | Reset | Description |
|-----|----------|------------|---|
| 0 | Stall | 0 | 0: Disable the endpoint STALL state. 1: Enable the endpoint STALL state. For EP0 OUT (control OUT endpoint) the STALL state will automatically be cleared by receiving a SETUP packet. When this bit is written to '0', the endpoint will reinitialize. Any data in the endpoint buffer will be flushed away, and the PID for next packet will carry DATA0 flag. |
| 7-1 | Reserved | 0b'xxxxxxx | Reserved |

Table 6.17 Endpoint Control Register

6.3.10 Acknowledge Setup

Command : F1h

Data : None

When receiving a SETUP packet the FT121 will flush the IN buffer and disable the Validate Buffer and Clear Buffer commands for both Control IN and Control OUT endpoints. The MCU shall read and process the SETUP packet, and then issue the Acknowledge Setup command to re-enable the Validate Buffer and Clear Buffer commands. The Acknowledge Setup command must be sent to both Control IN and Control OUT endpoints.

6.4 General Commands

6.4.1 Read Current Frame Number

Command : F5h

Data : Read One or Two Bytes

| Bit | Symbol | Reset | Description |
|-----|------------------|-------|---|
| 7-0 | Frame Number LSB | 00h | Frame number for last received SOF, byte 1 (least significant byte) |

Table 6.18 Frame Number LSB Register

| Bit | Symbol | Reset | Description |
|-----|------------------|----------|--|
| 2-0 | Frame Number MSB | 0b'000 | Frame number for last received SOF, byte 2 (Most significant byte) |
| 7-3 | Reserved | 0b'00000 | Reserved |

Table 6.19 Frame Number MSB Register

6.4.2 Send Resume

Command : F6h

Data : None

To perform remote-wakeup when suspended, the MCU needs to issue Send Resume command. The FT121 will send an upstream resume signal for a period of 10 ms. If the clock is not running during suspend, the MCU needs to wakeup FT121 by driving the SUSPEND pin to LOW, followed by the Send Resume command.

6.4.3 Set 3-wire Mode

Command : E8h

Data : None

This command is used to enable the 3-wire SPI mode. Once enabled, the MOSI pin will become bi-directional line and the MISO pin is not functional. Both SPI master and slave will drive data on the MOSI line.

6.4.4 Read Vendor ID

Command : EBh (for Enhanced Mode)

Data : read 2 bytes

Read the 2 bytes Vendor ID. Shall return 0403h.

6.4.5 Read Product ID

Command : EAh (for Enhanced Mode)

Data : read 2 bytes

Read the 2 bytes Product ID. Shall return 6018h.

6.4.6 Read FTDI ID

Command : EDh (for Enhanced Mode)

Data : read 1 byte

Read the 1 byte FTDI ID. Shall return 11h.

6.4.7 Set IO Pad Drive Strength

Command : E9h

Data : Write 1 byte

| Bit | Symbol | Reset | Description |
|-----|---------------------|-------|---|
| 1-0 | Reserved | 0b'00 | Reserved, write to 0b'00 |
| 3-2 | MISO, MOSI pins | 0b'00 | 00: 4mA 01: 8mA 10: 12mA 11:16mA |
| 5-4 | INT_n, SUSPEND pins | 0b'00 | 00: 4mA 01: 8mA 10: 12mA 11:16mA |
| 7-6 | Reserved | 0b'00 | Reserved, write to 0b'00 |

Table 6.20 IO Pad Drive Strength Register

7 Application Information

Figure 7-1 shows a reference application circuit for a USB bus-powered application. Figure 7-2 shows a reference application circuit for a USB self-powered application.

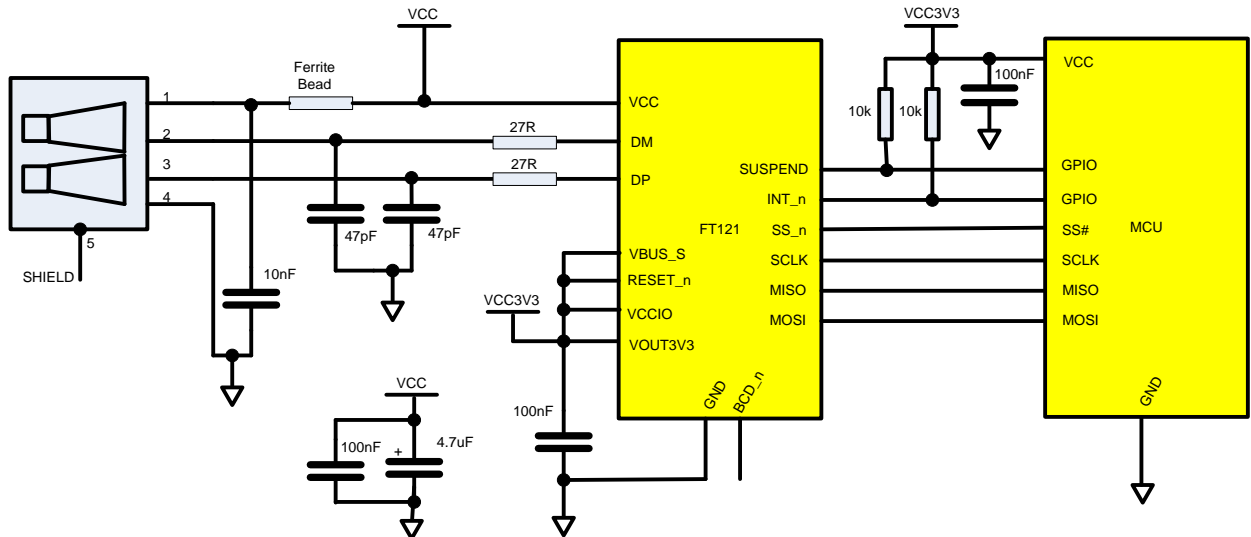

Figure 7-1 FT121 bus powered application

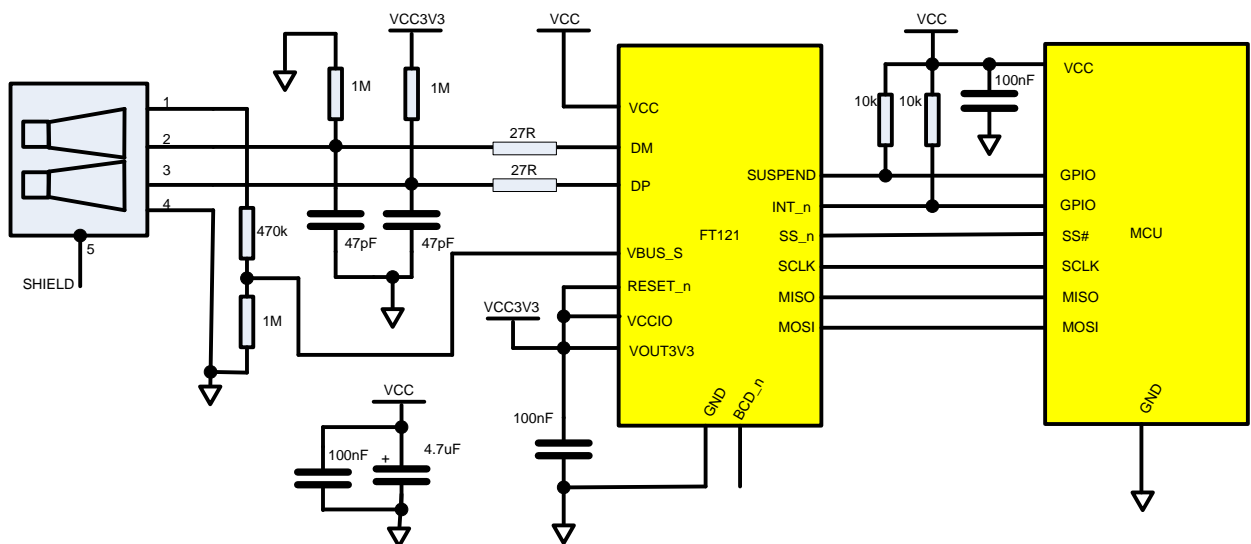

Figure 7-2 FT121 self powered application

8 Devices Characteristics and Ratings

8.1 Absolute Maximum Ratings

The absolute maximum ratings for the FT121 devices are as follows. These are in accordance with the Absolute Maximum Rating System (IEC 60134). Exceeding these may cause permanent damage to the device.

| Parameter | Value | Unit |
|--|---|-------|
| Storage Temperature | -65 to 150 | °C |
| Floor Life (Out of Bag) At Factory Ambient (30°C / 60% Relative Humidity) | 168 (IPC/JEDEC J-STD-033A MSL Level 3 Compliant)* | Hours |
| Ambient Temperature (Power Applied) | -40 to 85 | °C |
| Latch-up current | ±200 | mA |
| Electrostatic Discharge Voltage(ESD) human body model(HBM) | ±2 | kV |
| Electrostatic Discharge Voltage(ESD) machine model(MM) | ±200 | V |
| Electrostatic Discharge Voltage(ESD) charged device model(CDM) | ±500 | V |
| VCC Supply Voltage | -0.5 to +6.0 | V |
| DC Input Voltage – DP and DM | -0.5 to +3.8 | V |
| DC Input Voltage – High Impedance Bidirectional | -0.5 to + (VCC +0.5) | V |
| DC Input Voltage – All Other Inputs | -0.5 to + (VCC +0.5) | V |
| DC Output Current – Outputs | 22 | mA |

Table 8.1 Absolute Maximum Ratings

* If devices are stored out of the packaging beyond this time limit the devices should be baked before use. The devices should be ramped up to a temperature of +125°C and baked for up to 17 hours.

8.2 DC Characteristics

DC Characteristics (Ambient Temperature = -40°C to +85°C).

| Parameter | Description | Minimum | Typical | Maximum | Units | Conditions |
|-----------|--------------------------------|---------|---------|---------|-------|---|
| VCC1 | VCC Operating Supply Voltage | 4.0 | 5.0 | 5.5 | V | Normal Operation |
| VCC2 | VCC Operating Supply Voltage | 3.0 | 3.3 | 3.6 | V | Regulator by-pass mode Operation |
| VCCIO | VCCIO Operating Supply Voltage | 1.65 | | 3.6 | V | |
| Icc | Operating Supply Current | | 3.9 | | mA | Normal Operation, USB bus transmit or receive |
| Icc2 | Suspend Current | | 84 | | μA | USB Suspend, Clock Running = '0', excluding the DP_Pullup current |
| VOUT3V3 | 3.3v regulator output | 3.0 | 3.3 | 3.6 | V | VCC=5V |

Table 8.2 Operating Voltage and Current

| Parameter | Description | Minimum | Typical | Maximum | Units | Conditions |
|-----------|---------------------|---------|---------|---------|-------|----------------|
| Voh | Output Voltage High | 2.9 | | | V | I source = 4mA |
| Vol | Output Voltage Low | | | 0.4 | V | I sink = 4mA |
| Vih | Input Voltage High | 2.0 | | | V | |
| Vil | Input Voltage Low | - | | 0.8 | V | |

Table 8.3 digital I/O Pin Characteristics (VCCIO=+3.3V)

| Parameter | Description | Minimum | Typical | Maximum | Units | Conditions |
|-----------|---------------------|---------|---------|---------|-------|----------------|
| Voh | Output Voltage High | 2.25 | | | V | I source = 4mA |
| Vol | Output Voltage Low | | | 0.4 | V | I sink = 4mA |
| Vih | Input Voltage High | 1.7 | | | V | |
| Vil | Input Voltage Low | - | | 0.7 | V | |

Table 8.4 digital I/O Pin Characteristics (VCCIO=+2.5V)

| Parameter | Description | Minimum | Typical | Maximum | Units | Conditions |
|-----------|---------------------|---------|---------|---------|-------|----------------|
| Voh | Output Voltage High | 1.62 | | | V | I source = 4mA |
| Vol | Output Voltage Low | | | 0.4 | V | I sink = 4mA |
| Vih | Input Voltage High | 1.17 | | | V | |
| Vil | Input Voltage Low | - | | 0.63 | V | |

Table 8.5 digital I/O Pin Characteristics (VCCIO=+1.8V)

| Parameter | Description | Minimum | Typical | Maximum | Units | Conditions |
|-----------|--------------------------------|---------|---------|---------|----------|--|
| UVoh | I/O Pins Static Output (High) | 2.8 | | 3.6 | V | $R_L = 1.5k\Omega$ to 3.6 V |
| UVol | I/O Pins Static Output (Low) | - | | 0.3 | V | $R_L = 15k\Omega$ to GND |
| UVse | Single Ended Rx Threshold | 0.8 | | 2.0 | V | |
| UCom | Differential Common Mode | 0.8 | | 2.5 | V | |
| UVDif | Differential Input Sensitivity | 0.2 | | | V | |
| UDrvZ | Driver Output Impedance | 29 | - | 44 | Ω | Including external $27 \Omega \pm 1\%$ series resistor |

Table 8.6 USB I/O Pin (DP, DM) Characteristics

8.3 AC Characteristics

| Symbol | Parameter | VCCIO=3.3V | | VCCIO=1.8V | | Unit |
|--------|--|------------|-----|------------|-----|------|
| | | Min | Max | Min | Max | |
| t1 | SCLK period | 50 | | 60 | | ns |
| t2 | SCLK High period | 25 | | 30 | | ns |
| t3 | SCLK Low period | 25 | | 30 | | ns |
| t4 | SCLK driving edge to MOSI valid (3-wire mode) SCLK driving edge to MISO valid (4-wire mode) | 5 | 15 | 8 | 22 | ns |
| t5 | MOSI data setup time to sample SCLK edge | 5 | | 6 | | ns |
| t6 | MOSI data hold time from sample SCLK edge | 5 | | 5 | | ns |

| Symbol | Parameter | VCCIO=3.3V | | VCCIO=1.8V | | Unit |
|--------|--|------------|-----|------------|-----|------|
| | | Min | Max | Min | Max | |
| t7 | SS_n setup time to rising SCLK edge | 2 | | 2 | | ns |
| t8 | SS_n hold time from falling sample SCLK edge | 2 | | 2 | | ns |

Table 8.7 SPI slave timing

Note: All timing figures applied for both 4-wire and 3-wire modes.

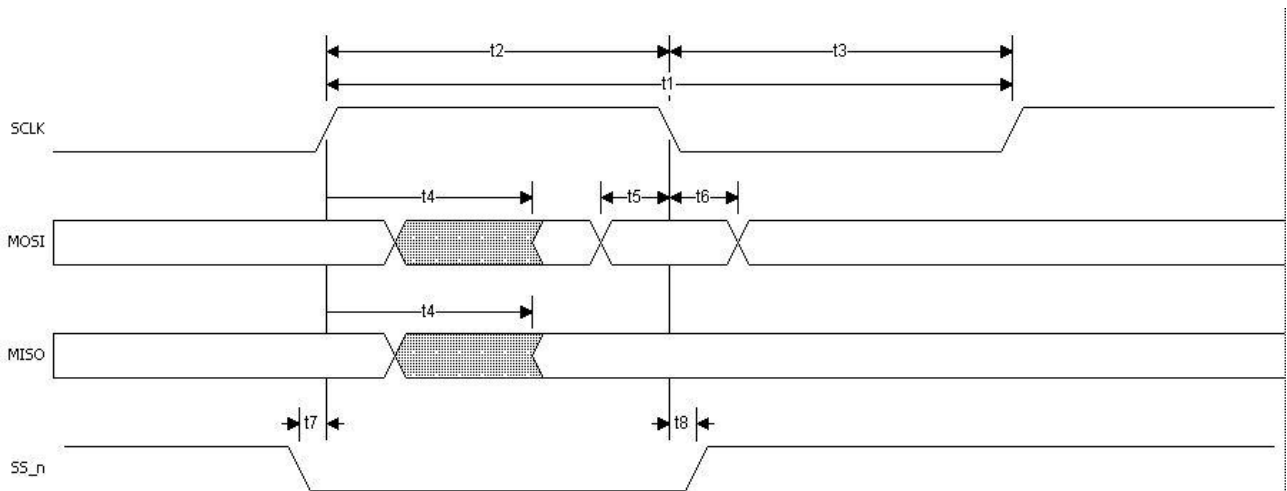
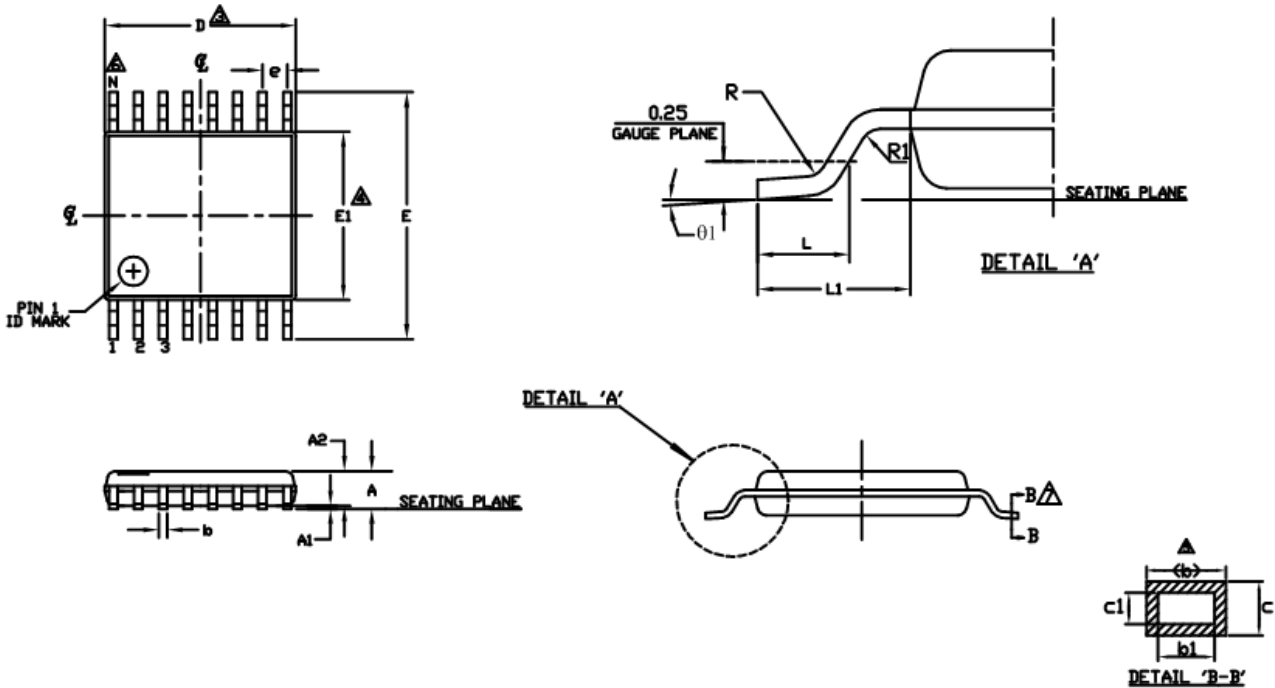

Figure 8-1 SPI slave timing

9 Package Parameters

The FT121 is available in two different packages. The FT121T is the TSSOP-16 package option and the FT121Q is the QFN-16 package option. The solder reflow profile for both packages is described in section 9.5.

9.1 TSSOP-16 Package Dimensions



| SYMBOL | 16L TSSOP | | |
|--------|--------------------------------------|------|------|
| | MIN | NOM. | MAX |
| A | — | — | 1.20 |
| A1 | 0.05 | — | 0.15 |
| A2 | 0.80 | 0.90 | 1.05 |
| D | 4.9 | 5.0 | 5.1 |
| E1 | 4.3 | 4.4 | 4.5 |
| E | 6.2 | 6.4 | 6.6 |
| L | 0.45 | 0.60 | 0.75 |
| R | 0.09 | — | — |
| R1 | 0.09 | — | — |
| b | 0.19 | — | 0.30 |
| b1 | 0.19 | 0.22 | 0.25 |
| c | 0.09 | — | 0.20 |
| c1 | 0.09 | — | 0.16 |
| θ1 | 0° | — | 8° |
| L1 | 1.0 REF | | |
| e | 0.65 BSC | | |
| N | 16 | | |
| Ref. | Jedec MO-153 Issue C Variation AB | | |

Notes

1. ALL DIMENSIONS ARE IN MILLIMETERS (ANGLES IN DEGREES).
 2. DIMENSIONING AND TOLERANCING PER ANSI Y14.5M-1982.
- ▲ DIMENSION 'D' DOES NOT INCLUDE MOLD FLASH, PROTRUSIONS OR GATE BURRS.
 - ▲ DIMENSION 'E1' DOES NOT INCLUDE INTERNAL FLASH OR PROTRUSION.
 - ▲ DIMENSION 'b' DOES NOT INCLUDE DAMBAR PROTRUSION.
 - ▲ 'N' IS THE MAXIMUM NUMBER OF LEAD TERMINAL POSITIONS FOR THE SPECIFIED PACKAGE LENGTH.
 - ▲ CROSS SECTION B-B TO BE DETERMINED AT 0.10 TO 0.25MM FROM THE LEAD TIP.

Figure 9-1 TSSOP-16 Package Dimensions

The FT121T is supplied in a RoHS compliant 16 pin TSSOP package. The package is lead (Pb) free and uses a 'green' compound. The package is fully compliant with European Union directive 2002/95/EC.

9.2 TSSOP-16 Package Markings

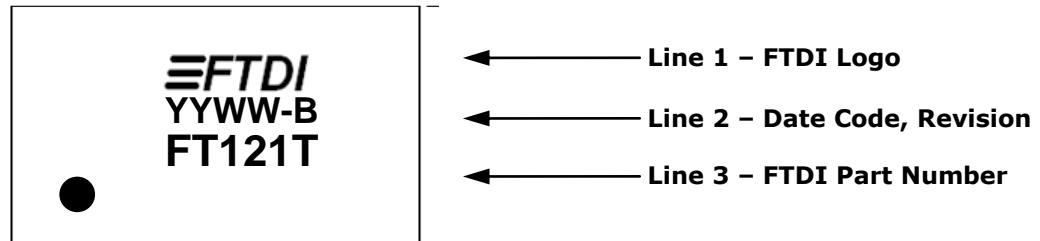

Figure 9-2 TSSOP-16 Package Markings

The date code format is **YYWW** where WW = 2 digit week number, YY = 2 digit year number.

9.3 QFN-16 Package Dimensions

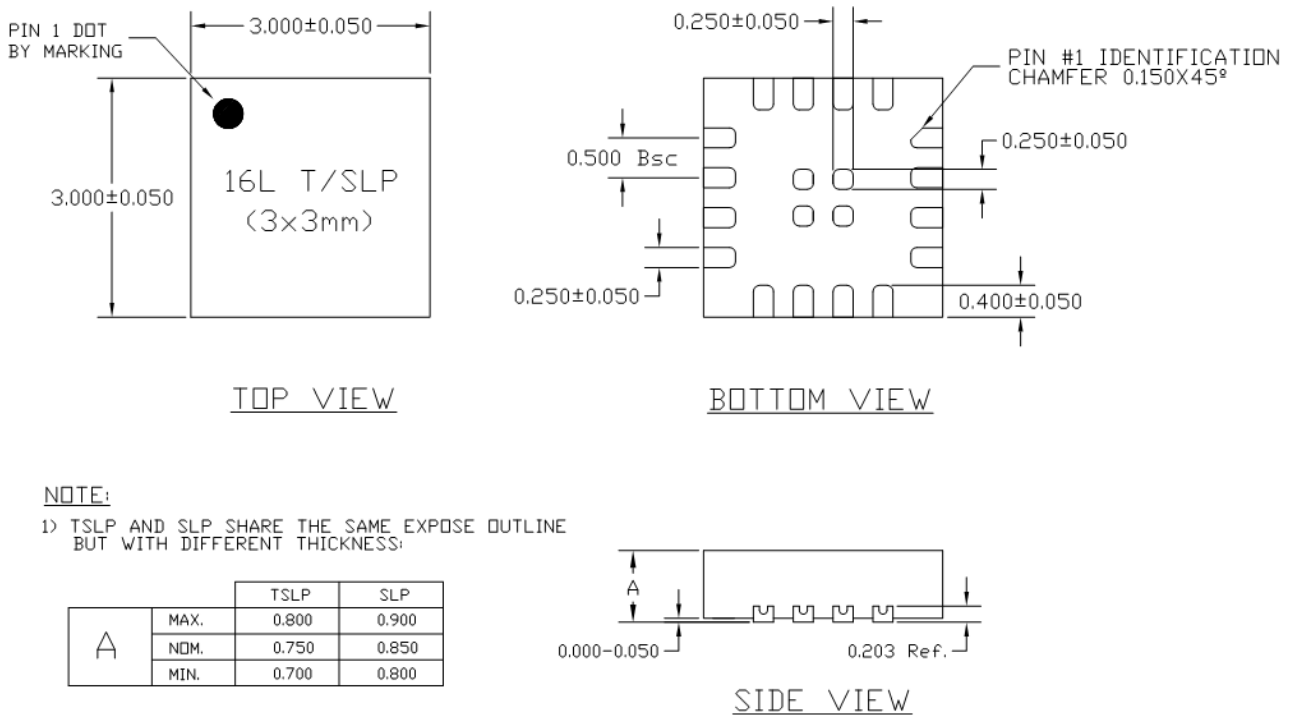

Figure 9-3 QFN-16 Package Dimensions

The FT121Q is supplied in a RoHS compliant leadless QFN-16 package. The package is lead (Pb) free, and uses a 'green' compound. The package is fully compliant with European Union directive 2002/95/EC.

This package is nominally 3mm x 3mm. The solder pads are on a 0.50mm pitch. The above mechanical drawing shows the QFN-16 package. All dimensions are in millimetres.

The center pads at the base of the FT121Q are internally connected to a power signal according to the following table. These may be left unconnected or routed to the respective power signal:

| Pad Number | Signal | Location – top view | Location – bottom view |
|------------|---------|---------------------|------------------------|
| 17 | Ground | Upper left | Upper right |
| 18 | VCCIO | Lower left | Lower right |
| 19 | VOUT3V3 | Lower right | Lower left |
| 20 | VCC | Upper right | Upper left |

Table 9.1 FT121Q Bottom Pad Assignments

9.4 QFN-16 Package Markings

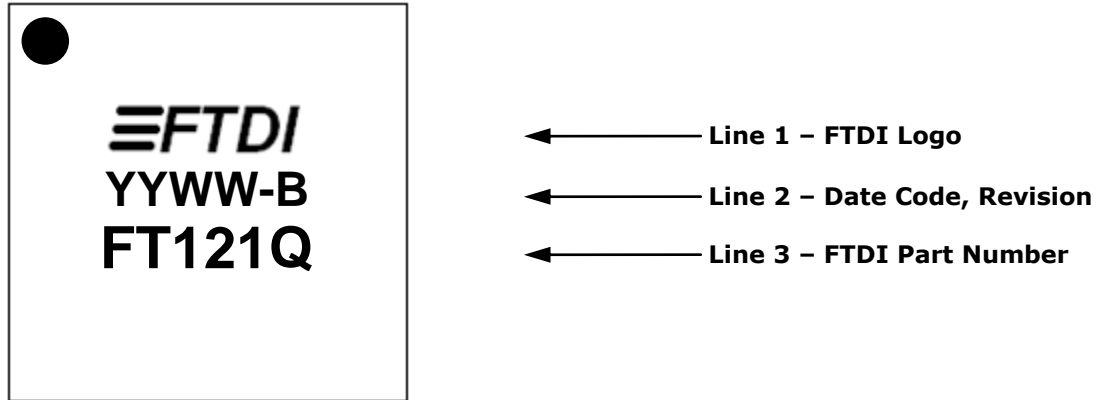

Figure 9-4 QFN-16 Package Markings

The date code format is **YYWW** where WW = 2 digit week number, YY = 2 digit year number.

9.5 Solder Reflow Profile

The FT121 is supplied in Pb free TSSOP-16 and QFN-16 packages. The recommended solder reflow profile for both package options is shown in Figure 9-5.

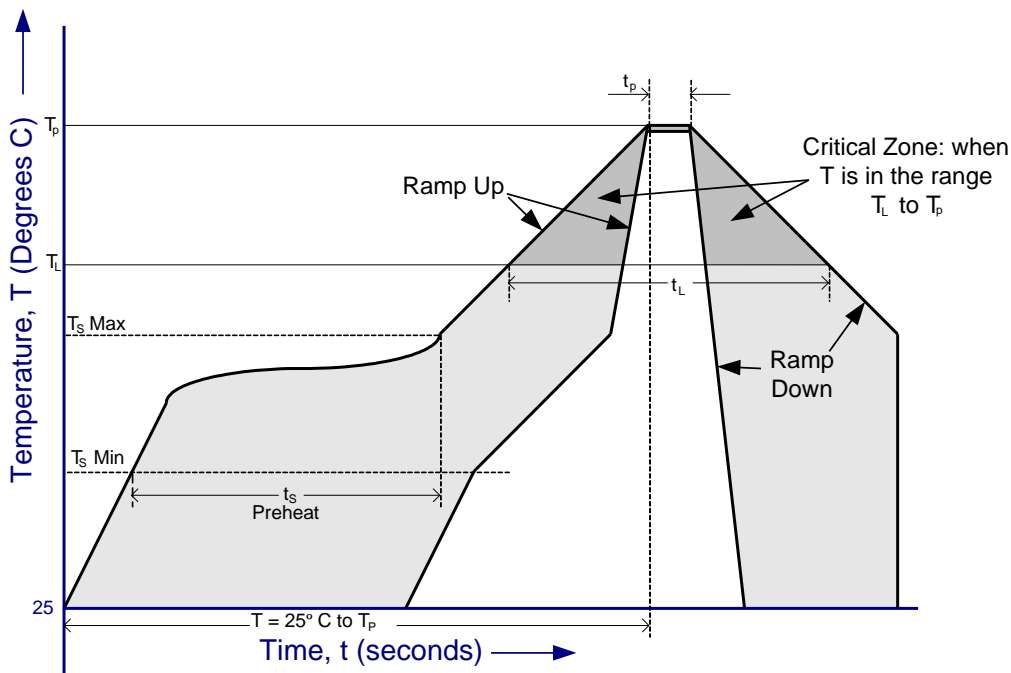

Figure 9-5 FT121 Solder Reflow Profile

The recommended values for the solder reflow profile are detailed in Table 9.2. Values are shown for both a completely Pb free solder process (i.e. the FT121 is used with Pb free solder), and for a non-Pb free solder process (i.e. the FT121 is used with non-Pb free solder).

| Profile Feature | Pb Free Solder Process | Non-Pb Free Solder Process |
|---|-------------------------------------|-------------------------------------|
| Average Ramp Up Rate (T_s to T_p) | 3°C / second Max. | 3°C / Second Max. |
| Preheat - Temperature Min (T_s Min.) - Temperature Max (T_s Max.) - Time (t_s Min to t_s Max) | 150°C 200°C 60 to 120 seconds | 100°C 150°C 60 to 120 seconds |
| Time Maintained Above Critical Temperature T_L : - Temperature (T_L) - Time (t_L) | 217°C 60 to 150 seconds | 183°C 60 to 150 seconds |
| Peak Temperature (T_p) | 260°C | 240°C |
| Time within 5°C of actual Peak Temperature (t_p) | 20 to 40 seconds | 20 to 40 seconds |
| Ramp Down Rate | 6°C / second Max. | 6°C / second Max. |
| Time for $T = 25^\circ\text{C}$ to Peak Temperature, T_p | 8 minutes Max. | 6 minutes Max. |

Table 9.2 Reflow Profile Parameter Values

10 Contact Information

Head Office – Glasgow, UK

Future Technology Devices International Limited
Unit 1, 2 Seaward Place, Centurion Business Park
Glasgow G41 1HH
United Kingdom
Tel: +44 (0) 141 429 2777
Fax: +44 (0) 141 429 2758

E-mail (Sales) sales1@ftdichip.com
E-mail (Support) support1@ftdichip.com
E-mail (General Enquiries) admin1@ftdichip.com

Branch Office – Tigard, Oregon, USA

Future Technology Devices International Limited
(USA)
7130 SW Fir Loop
Tigard, OR 97223
Tel: +1 (503) 547 0988
Fax: +1 (503) 547 0987

E-Mail (Sales) us.sales@ftdichip.com
E-Mail (Support) us.support@ftdichip.com
E-Mail (General Enquiries) us.admin@ftdichip.com

Branch Office – Taipei, Taiwan

Future Technology Devices International Limited
(Taiwan)
2F, No. 516, Sec. 1, NeiHu Road
Taipei 114
Taiwan, R.O.C.
Tel: +886 (0) 2 8791 3570
Fax: +886 (0) 2 8791 3576

E-mail (Sales) tw.sales1@ftdichip.com
E-mail (Support) tw.support1@ftdichip.com
E-mail (General Enquiries) tw.admin1@ftdichip.com

Branch Office – Shanghai, China

Future Technology Devices International Limited
(China)
Room 1103, No.666 West Huaihai Road,
Shanghai, 200052
China
Tel: +86 21 62351596
Fax: +86 21 62351595

E-mail (Sales) cn.sales@ftdichip.com
E-mail (Support) cn.support@ftdichip.com
E-mail (General Enquiries) cn.admin@ftdichip.com

Branch Office – Singapore

Future Technology Devices International Limited (Singapore)
178 Paya Lebar Road
#07-03/04/05
Singapore 409030
Tel: +65 6841 1174
Fax: +65 6841 6071

E-mail (Support) support1@ftdichip.com
E-mail (General Enquiries) admin1@ftdichip.com

Web Site

<http://ftdichip.com>

System and equipment manufacturers and designers are responsible to ensure that their systems, and any Future Technology Devices International Ltd (FTDI) devices incorporated in their systems, meet all applicable safety, regulatory and system-level performance requirements. All application-related information in this document (including application descriptions, suggested FTDI devices and other materials) is provided for reference only. While FTDI has taken care to assure it is accurate, this information is subject to customer confirmation, and FTDI disclaims all liability for system designs and for any applications assistance provided by FTDI. Use of FTDI devices in life support and/or safety applications is entirely at the user's risk, and the user agrees to defend, indemnify and hold harmless FTDI from any and all damages, claims, suits or expense resulting from such use. This document is subject to change without notice. No freedom to use patents or other intellectual property rights is implied by the publication of this document. Neither the whole nor any part of the information contained in, or the product described in this document, may be adapted or reproduced in any material or electronic form without the prior written consent of the copyright holder. Future Technology Devices International Ltd, Unit 1, 2 Seaward Place, Centurion Business Park, Glasgow G41 1HH, United Kingdom. Scotland Registered Company Number: SC136640

Appendix A – References

Useful Application Notes

- http://www.ftdichip.com/Documents/AppNotes/AN_167_FT1248_Parallel_Serial_Interface_Basics.pdf
- http://www.ftdichip.com/Support/Documents/TechnicalNotes/TN_100_USB_VID-PID_Guidelines.pdf
- http://www.ftdichip.com/Support/Documents/AppNotes/AN_175_Battery%20Charging%20Over%20USB%20with%20FTEX%20Devices.pdf
- http://www.usb.org/developers/devclass_docs/BCv1.2_011912.zip

Appendix B - List of Figures and Tables

List of Figures

| | |
|--|----|
| Figure 2-1 FT121 Block Diagram..... | 3 |
| Figure 3-1 TSSOP-16 package schematic symbol | 6 |
| Figure 3-2 QFN-16 package schematic symbol..... | 6 |
| Figure 4-1 SPI access..... | 11 |
| Figure 4-2 4-wire write operation..... | 11 |
| Figure 4-3 4-wire read operation | 12 |
| Figure 4-4 3-wire write operation..... | 12 |
| Figure 4-5 3-wire read operation | 12 |
| Figure 7-1 FT121 bus powered application | 33 |
| Figure 7-2 FT121 self powered application | 33 |
| Figure 8-1 SPI slave timing | 37 |
| Figure 9-1 TSSOP-16 Package Dimensions | 38 |
| Figure 9-2 TSSOP-16 Package Markings | 39 |
| Figure 9-3 QFN-16 Package Dimensions | 40 |
| Figure 9-4 QFN-16 Package Markings | 41 |
| Figure 9-5 FT121 Solder Reflow Profile | 41 |

List of Tables

| | |
|--|----|
| Table 3.1 FT121 Pin Description..... | 7 |
| Table 4.1 Interrupt modes | 10 |
| Table 5.1 Endpoint configuration for EP0 and EP1 | 14 |
| Table 5.2 Endpoint configuration for EP2 | 14 |
| Table 5.3 Example buffer configuration..... | 15 |
| Table 5.4 Endpoint Maximum Packet Size | 16 |
| Table 6.1 FT121 default command set | 18 |
| Table 6.2 enhanced command set..... | 22 |
| Table 6.3 Address Enable Register | 22 |
| Table 6.4 Endpoint Enable Register | 22 |
| Table 6.5 Configuration Register (Byte 1) | 23 |
| Table 6.6 Configuration Register (Byte 2) | 23 |
| Table 6.7 Interrupt Configuration Register | 24 |

| | |
|--|----|
| Table 6.8 Endpoint Configuration Register..... | 24 |
| Table 6.9 Interrupt Register Byte 1 | 25 |
| Table 6.10 Interrupt Register Byte 2 | 25 |
| Table 6.11 Interrupt Register Byte 3 (for Enhanced Mode) | 26 |
| Table 6.12 Interrupt Register Byte 4 (for Enhanced Mode) | 26 |
| Table 6.13 Endpoint Status Register..... | 27 |
| Table 6.14 Endpoint Last Transaction Status Register..... | 27 |
| Table 6.15 Transaction error code..... | 28 |
| Table 6.16 Endpoint Buffer Status Register | 29 |
| Table 6.17 Endpoint Control Register | 30 |
| Table 6.18 Frame Number LSB Register..... | 31 |
| Table 6.19 Frame Number MSB Register | 31 |
| Table 6.20 IO Pad Drive Strength Register | 32 |
| Table 8.1 Absolute Maximum Ratings | 34 |
| Table 8.2 Operating Voltage and Current | 35 |
| Table 8.3 digital I/O Pin Characteristics (VCCIO=+3.3V)..... | 35 |
| Table 8.4 digital I/O Pin Characteristics (VCCIO=+2.5V)..... | 35 |
| Table 8.5 digital I/O Pin Characteristics (VCCIO=+1.8V)..... | 36 |
| Table 8.6 USB I/O Pin (DP, DM) Characteristics | 36 |
| Table 8.7 SPI slave timing | 37 |
| Table 9.1 FT121Q Bottom Pad Assignments | 40 |
| Table 9.2 Reflow Profile Parameter Values | 42 |

Appendix C - Revision History

Document Title: DS_FT121
Document Reference No.: FT_000648
Clearance No.: FTDI# 312
Product Page: <http://www.ftdichip.com/Products/ICs/FT121.htm>
Document Feedback: [Send Feedback](#)

| | | |
|----------------------|---------------------------------------|------------------------------|
| Version Draft | Initial draft | July 2012 |
| Version 1.0 | Initial release | 1 st October 2012 |
| Version 1.1 | Updated FT121Q bottom pad assignments | 15 th July 2013 |
| Version 1.2 | Updated release | 23 rd Mar 2015 |