

Outdoor Sensor Humidity, Temperature active with weather shield

Active humidity and temperature sensor for outside applications. The radiation shield protects the outside sensors from rain and radiated heat. With the curved shape and color of the plates air flow is able to move across the sensors to keep radiated temperatures from rooftops and surrounding surfaces from affecting humidity readings. With Modbus RTU communication and integrated 0..10V outputs. NEMA 4X / IP65 rated enclosure.



Type Overview

Type	Output signal	Output signal active temperature	Output signal active humidity
22UTH-550X	Modbus	DC 0...5 V, DC 0...10 V	DC 0...5 V, DC 0...10 V

Technical Data

Electrical Data	Power supply DC	15...24 V, $\pm 10\%$, 0.7 W
	Power supply AC	24 V, , $\pm 10\%$, 1.8 VA
	Electrical connection	Removable spring loaded terminal block max. 2.5 mm ²
	Cable entry	Cable gland with strain relief 2 x Ø6 mm (1/2" NPT conduit adapter included)
Functional Data	Sensor Technology	polymer capacitive sensor with stainless steel wire mesh
	Communicative control	Modbus RTU
	Output signal active note	Output DC 0...5/10 V selectable with switch
Measuring Data	Application	air
	Measuring values	temperature relative humidity dew point enthalpy absolute humidity
	Measuring range humidity	0...100% r.H. selectable via Modbus
	Measuring range temperature	selectable via Modbus Attention: max. measuring temperature is restricted by max. fluid temperature (see Safety data)
	Measuring range absolute humidity	0...80 g/m ³ selectable via Modbus
	Measuring range enthalpy	0...85 kJ/kg selectable via Modbus
	Measuring range dew point	0...200°F [-20...80°C] selectable via Modbus
	Accuracy humidity	$\pm 2\%$ between 10...90% r.H. @ 70°F [21°C]
	Accuracy temperature active	$\pm 0.9^\circ\text{F}$ @ 77°F [$\pm 0.5^\circ\text{C}$ @ 25°C]

Materials	Cable gland	PA6, black
	Housing	cover: lexan, gray base: lexan, gray seal: 0467 NBR70, black UV resistant
Safety Data	Ambient humidity	short-term condensation permitted
	Medium humidity	short-term condensation permitted
	Ambient temperature	-30...120°F [-35...50°C]
	Fluid temperature	-30...120°F [-35...50°C]
	Operating condition air flow	max. 40 ft/s [12 m/s]
	Protection class IEC/EN	III safety extra-low voltage (selv)
	Protection class UL	UL Class 2 Supply
	EU Conformity	CE Marking
	Certification IEC/EN	IEC/EN 60730-1
	Certification UL	cULus acc. to UL60730-1A/-2-9/-2-13, CAN/ CSA E60730-1:02/-2-9
	Degree of protection IEC/EN	IP65
	Quality Standard	ISO 9001

Safety Notes

This device has been designed for use in stationary heating, ventilation and air-conditioning systems and must not be used outside the specified field of application. Unauthorised modifications are prohibited. The product must not be used in relation with any equipment that in case of a failure may threaten humans, animals or assets.

Ensure all power is disconnected before installing. Do not connect to live/operating equipment.

Only authorised specialists may carry out installation. All applicable legal or institutional installation regulations must be complied during installation.

The device contains electrical and electronic components and must not be disposed of as household refuse. All locally valid regulations and requirements must be observed.

Remarks

- General Remarks Concerning Sensors** When using lengthy connection wires (depending on the cross section used) the measuring result might be falsified due to a voltage drop at the common GND-wire (caused by the voltage current and the line resistance). In this case, 2 GND-wires must be wired to the sensor - one for supply voltage and one for the measuring current.
- Sensing devices with a transducer should always be operated in the middle of the measuring range to avoid deviations at the measuring end points. The ambient temperature of the transducer electronics should be kept constant. The transducers must be operated at a constant supply voltage (± 0.2 V). When switching the supply voltage on/off, onsite power surges must be avoided.
- Build-up of Self-Heating by Electrical Dissipative Power** Temperature sensors with electronic components always have a dissipative power which affects the temperature measurement of the ambient air. The dissipation in active temperature sensors shows a linear increase with rising operating voltage. This dissipative power should be taken into account when measuring temperature. As Belimo transducers work with a variable operating voltage, only one operating voltage can be taken into consideration, for reasons of production engineering. Transducers 0...10 V / 4...20 mA have a standard setting at an operating voltage of DC 24 V. That means, that at this voltage, the expected measuring error of the output signal will be the least. For other operating voltages, the offset error will be increased by a changing power loss of the sensor electronics. If a re-calibration should become necessary later directly on the sensor, this can be done by means of a trimming potentiometer on the sensor board.
- Application Notice for Humidity Sensors** Refrain from touching the sensitive humidity sensor/element. Touching the sensitive surface will void warranty.
- For standard environmental conditions the manufacturing accuracy specified in the datasheet will be covered by the calibration warranty for two years. When exposed to harsh environmental conditions such as high ambient temperature and/or high levels of humidity, or presence of aggressive gases (i.e. chlorine, ozone, ammonia) the sensor element may be affected and readings may be outside specified accuracy. Replacement of deteriorated humidity sensors due to harsh environmental conditions are not subject of the general warranty.

Scope of delivery

- Dowel
- Screws
- Cable Gland with strain relief $\varnothing 6...8$ mm
- 1/2" NPT conduit adapter

Accessories

Optional accessories	Description	Type
	Replacement filter, wire mesh, Stainless steel	A-22D-A06

Wiring Diagram

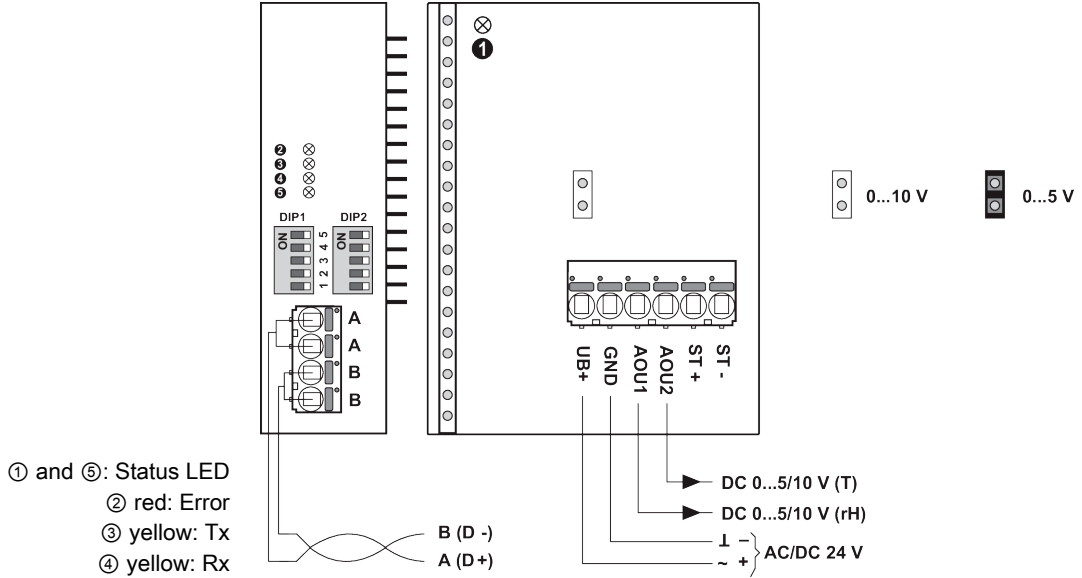

Connectors ST+ / ST- are only used for sensor types which additionally have a passive resistance sensor element for temperature measurement.
 Correct temperature values are only available, when the humidity output AOI1 and both inputs UB + are connected.
 The adjustment of the measuring ranges is made by changing the bonding jumpers.
 The output value in the new measuring range is available after 2 seconds.

Detailed documentation

The separate document Sensor Modbus-Register informs about Modbus register, addressing, parity and bus termination (DIP1: address, DIP2: baud rate, parity, bus termination)

Notes Wiring RS485



Connection via safety isolating transformer.
 Parallel connection of other devices possible. Observe the performance data.
 The wiring of the line for BACnet MS/TP / Modbus RTU is to be carried out in accordance with applicable RS485 regulations.
 Modbus / BACnet: Supply and communication are not galvanically isolated. Connect earth signal of the devices with one another.

Wiring RS485 (Modbus RTU & BACnet MS/TP)

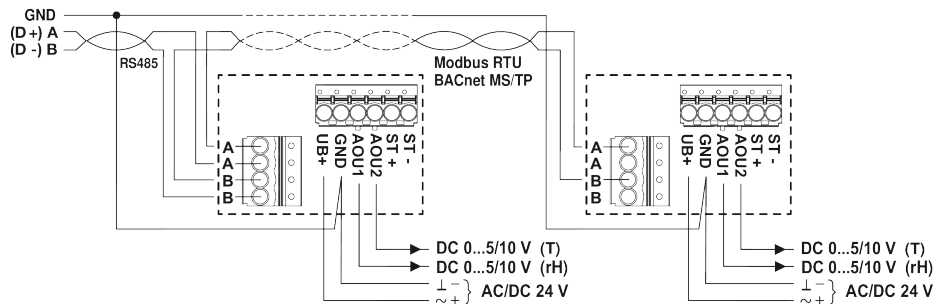

Dimensions

Dimensions

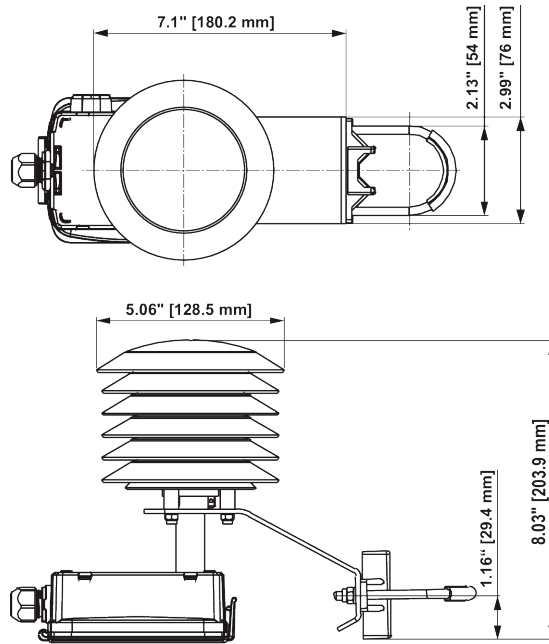

Type	Weight
22UTH-550X	1.48 lb [0.67 kg]