

Specification

Patent Pending

- Part Number : **PA.710.A WARRIOR**
- Product Name : Ultra Wideband LTE/Cellular/CDMA SMD Antenna
For 4G/3G/2G Applications
LTE / GSM / CDMA /DCS /PCS / WCDMA / UMTS /
HSDPA / GPRS / EDGE /IMT
698MHz to 960MHz, 1710MHz to 2690Mhz
- Features : High Efficiency Wideband Antenna
Manufactured in an IATF16949 Certified Facility
Surface Mount Distribution
40.0x5.0x6.0 mm size
RoHS Compliant ✓



1. Introduction

The Warrior, the revolutionary patent pending PA.710A is a 4G/3G/2G, High Efficiency SMD Ceramic antenna, operating at 698MHz to 960MHz and 1710MHz to 2690MHz. It uses high grade custom ceramic material and new design techniques to deliver the highest efficiencies on all bands when mounted on the device's main PCB. The exceptional wide-band response means it is the ideal antenna for all LTE applications that also need high efficiency and backward compatibility for 3G and 2G globally on all lower and upper bands. The PA.710A is delivered on tape and reel and mounted securely during the device PCB reflow process.

1.1 Key Advantages

1. **Highest efficiency in a small size, i.e. 40mm*5mm*6mm.** A comparative antenna, for example metal/FR4/FPC/whip/rod/helix, would have much reduced efficiency in this configuration due to their different dielectric constants. Very high efficiency antennas are critical to 3G and 4G devices ability to deliver the stated data-speed rates of systems such as HSPA and LTE.
2. **More resistant to detuning compared to other antenna integrations.** If tuning is required it can be tuned for the device environment using a matching circuit, or other techniques on the main PCB itself. There is no need for new tooling, thereby saving money if customization is required.
3. **Highly reliable and robust**– its predecessors the PA.25A and PA700A antennas are used by the world's leading automotive makers in extremely challenging environments. The antenna meets all temperature and mechanical specs required (vibration, drop tests, etc)
4. **Easy to integrate.** Other antenna designs come in irregular shapes and sizes making them more difficult to integrate.
5. **Surface Mount Distribution (Directly On-Board)** antenna saves on labor, cable and connector costs, leads to higher integration yield rates, and reduces losses in transmission.



6. **Minimum Transmission and Reception Losses** - these are kept to absolute minimum resulting in much improved OTA (over the air), i.e. TRP (Total Radiated Power)/TIS (Total Isotropic Radiation), device performance compared to similar efficiency cable and connector antenna solutions. This means it is an ideal antenna to be used for devices that need to pass for example USA carrier network approvals

7. **RSE Reductions** – will help to eliminate radiated spurious emission failures compared to other antenna technologies as the required layout for the antenna can deliver natural isolation between the onboard noise and the antenna itself. Also the antenna can be matched better to the system with the matching circuit function.

8. **High Gain in Both Polarization Planes** - Achieves moderate to high gain in both vertical and horizontal polarization planes. This feature is very useful in certain wireless communications where the antenna orientation is not fixed and the reflections or multipath signals may be present from any plane. In those cases, the important parameter to be considered is the total field strength, which is the vector sum of the signal from the horizontal and vertical polarization planes at any instant in time.

2. Specification

ELECTRICAL						
Standard	4G/3G/2G					
Operation Frequency	698~960 MHz	703~803 MHz	1710~2170 MHz	2300~2400 MHz	2490~2690 MHz	3400~3600 MHz
Peak Gain	1.0dBi		3.2dBi	3.5dBi	3.5dBi	
Average Gain	-2.3 dB		-1.5dB	-1.8dB	-1.5dB	
Efficiency	60%		70%	65%	70%	
VSWR	<3.0:1					
Impedance	50Ω					
Polarization	Linear					
Radiation Properties	Omni-directional					
Max Input Power	5 W					

- The Warrior PA.710.A antenna performance was measured with 120x45mm ground plane.

MECHANICAL	
Dimensions	40 x 5 x 6 mm
Material	Ceramic
Termination	Ag (environmental-friendly Pb free)
EVB Connector	SMA(F)

ENVIRONMENTAL	
Operation Temperature	-40°C to 85°C
Storage Temperature	-40°C to 85°C
Relative Humidity	Non-condensing 65°C 95% RH
RoHs Compliant	Yes

LTE BANDS			
Band Number	LTE / LTE-Advanced / WCDMA / HSPA / HSPA+ / TD-SCDMA		
	Uplink	Downlink	PA710.A
1	UL: 1920 to 1980	DL: 2110 to 2170	✓
2	UL: 1850 to 1910	DL: 1930 to 1990	✓
3	UL: 1710 to 1785	DL: 1805 to 1880	✓
4	UL: 1710 to 1755	DL: 2110 to 2155	✓
5	UL: 824 to 849	DL: 869 to 894	✓
7	UL: 2500 to 2570	DL: 2620 to 2690	✓
8	UL: 880 to 915	DL: 925 to 960	✓
9	UL: 1749.9 to 1784.9	DL: 1844.9 to 1879.9	✓
11	UL: 1427.9 to 1447.9	DL: 1475.9 to 1495.9	✗
12	UL: 699 to 716	DL: 729 to 746	✓
13	UL: 777 to 787	DL: 746 to 756	✓
14	UL: 788 to 798	DL: 758 to 768	✓
17	UL: 704 to 716	DL: 734 to 746 (LTE only)	✓
18	UL: 815 to 830	DL: 860 to 875 (LTE only)	✓
19	UL: 830 to 845	DL: 875 to 890	✓
20	UL: 832 to 862	DL: 791 to 821	✓
21	UL: 1447.9 to 1462.9	DL: 1495.9 to 1510.9	✗
22	UL: 3410 to 3490	DL: 3510 to 3590	✗
23	UL: 2000 to 2020	DL: 2180 to 2200 (LTE only)	✓
24	UL: 1625.5 to 1660.5	DL: 1525 to 1559 (LTE only)	✓
25	UL: 1850 to 1915	DL: 1930 to 1995	✓
26	UL: 814 to 849	DL: 859 to 894	✓
27	UL: 807 to 824	DL: 852 to 869 (LTE only)	✓
28	UL: 703 to 748	DL: 758 to 803 (LTE only)	✓
29	UL: -	DL: 717 to 728 (LTE only)	✓
30	UL: 2305 to 2315	DL: 2350 to 2360 (LTE only)	✓
31	UL: 452.5 to 457.5	DL: 462.5 to 467.5 (LTE only)	✗
32	UL: -	DL: 1452 - 1496	✓
35		1850 to 1910	✓
38		2570 to 2620	✓
39		1880 to 1920	✓
40		2300 to 2400	✓
41		2496 to 2690	✓
42		3400 to 3600	✗
43		3600 to 3800	✗

*Covered bands represent an efficiency greater than 20%

3. Test Setup

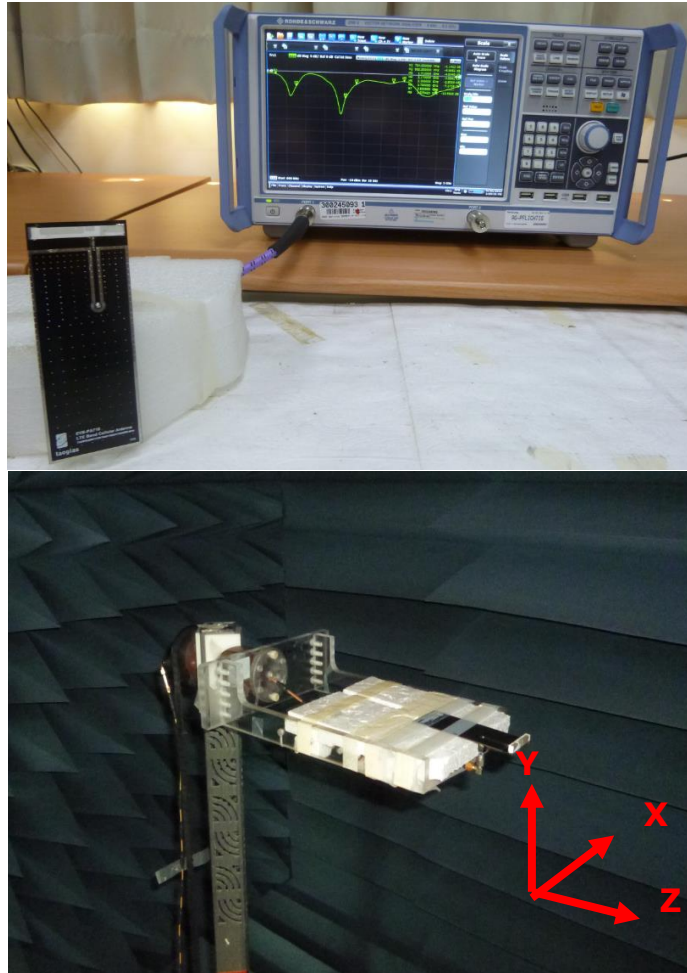

Figure 1. Impedance measurements (left hand) and peak gain, average gain, efficiency and radiation pattern measurements (right hand)

4. Antenna Parameters

4.1. Return Loss

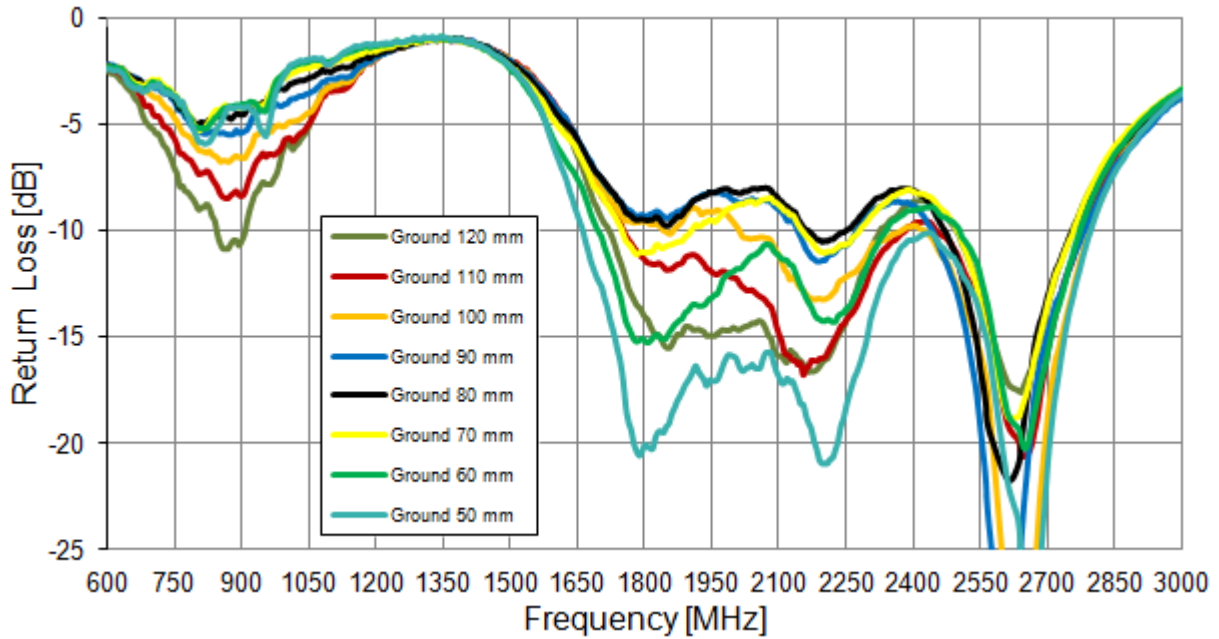

Figure 2. Return Loss of the Warrior PA710 LTE antenna

4.2. VSWR

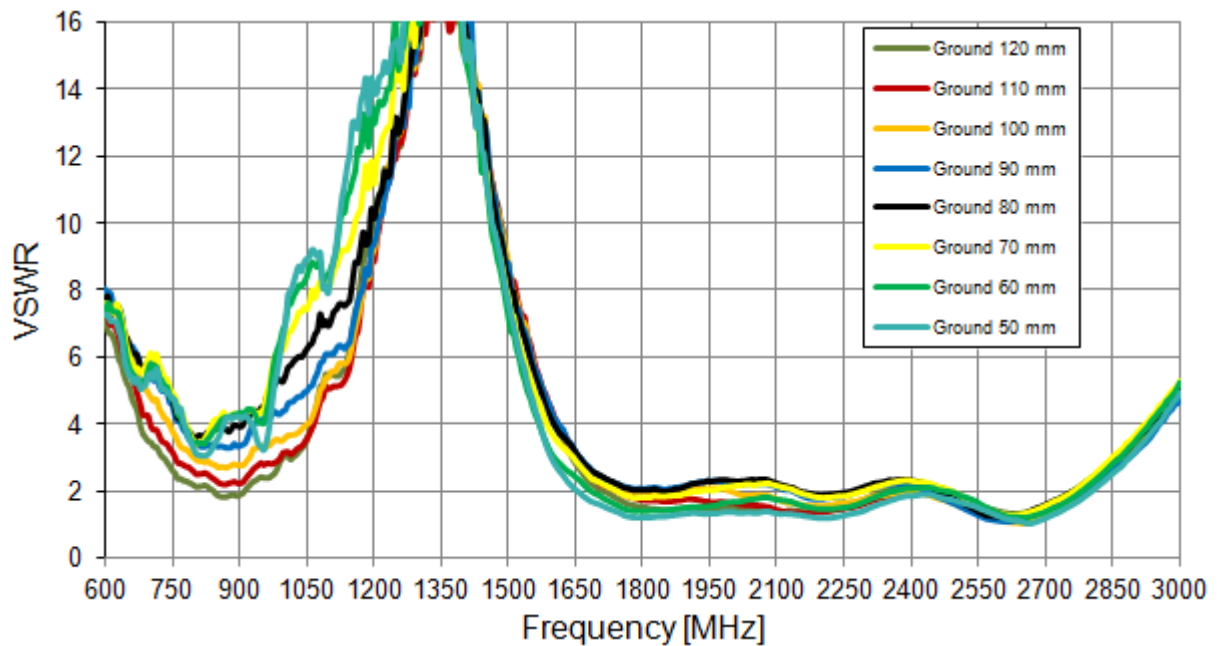

Figure 3. VSWR of the Warrior PA710 LTE antenna

4.3. Efficiency

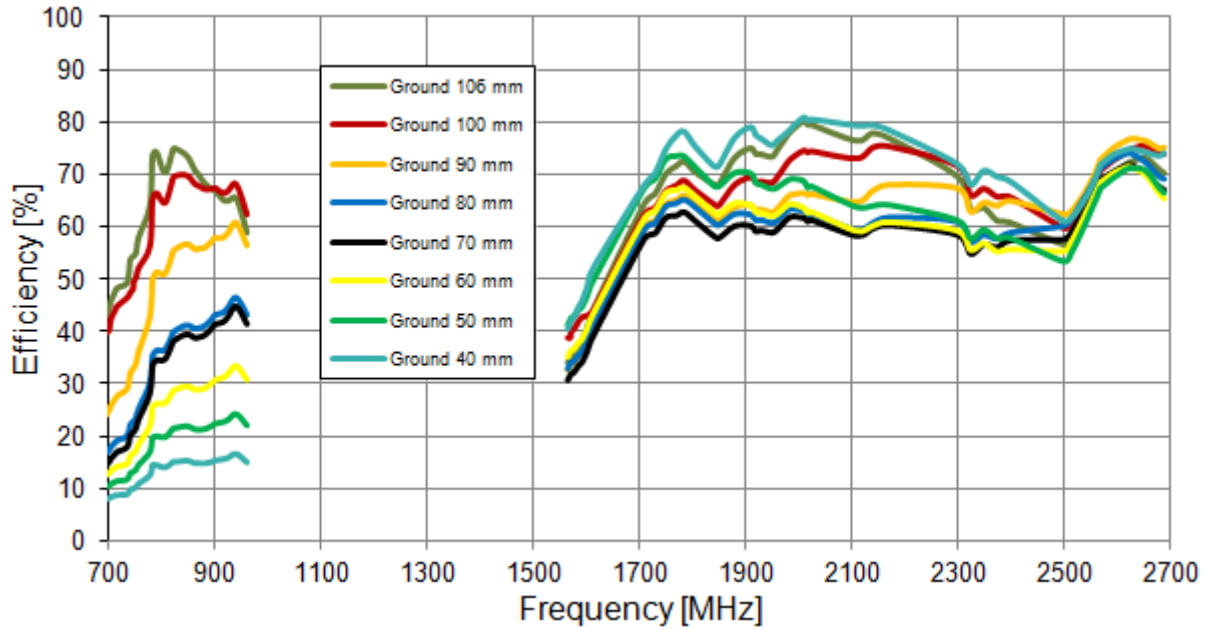

Figure 4. Efficiency of the Warrior PA710 LTE antenna

4.4. Peak Gain

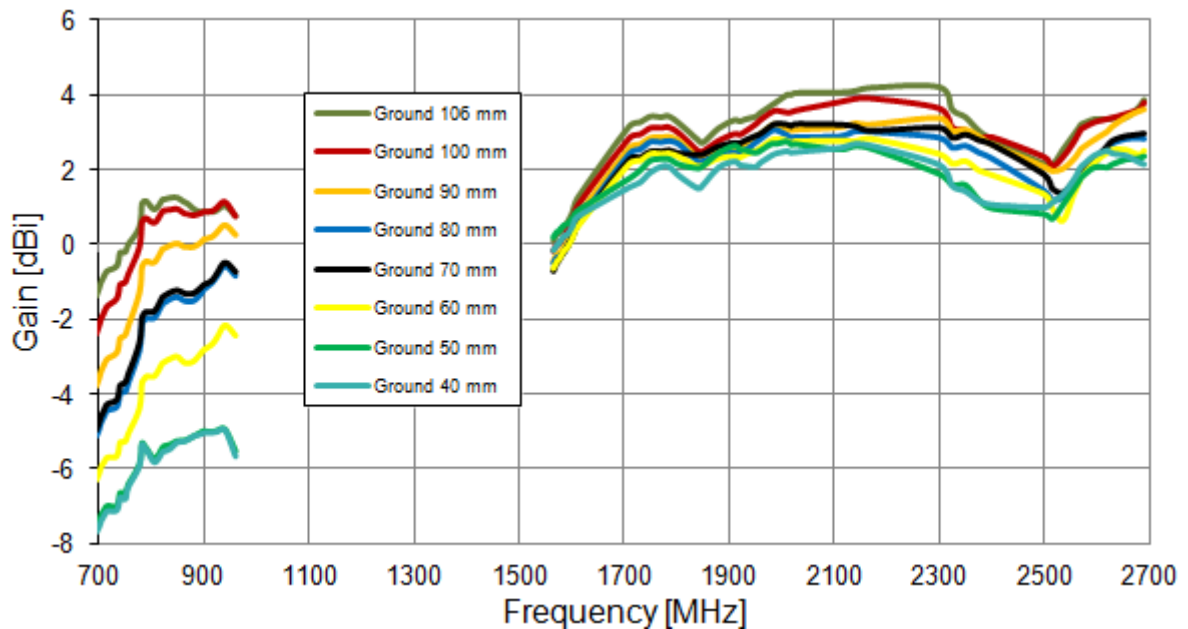

Figure 5. Peak Gain of the Warrior PA710 LTE antenna

4.5. Average Gain

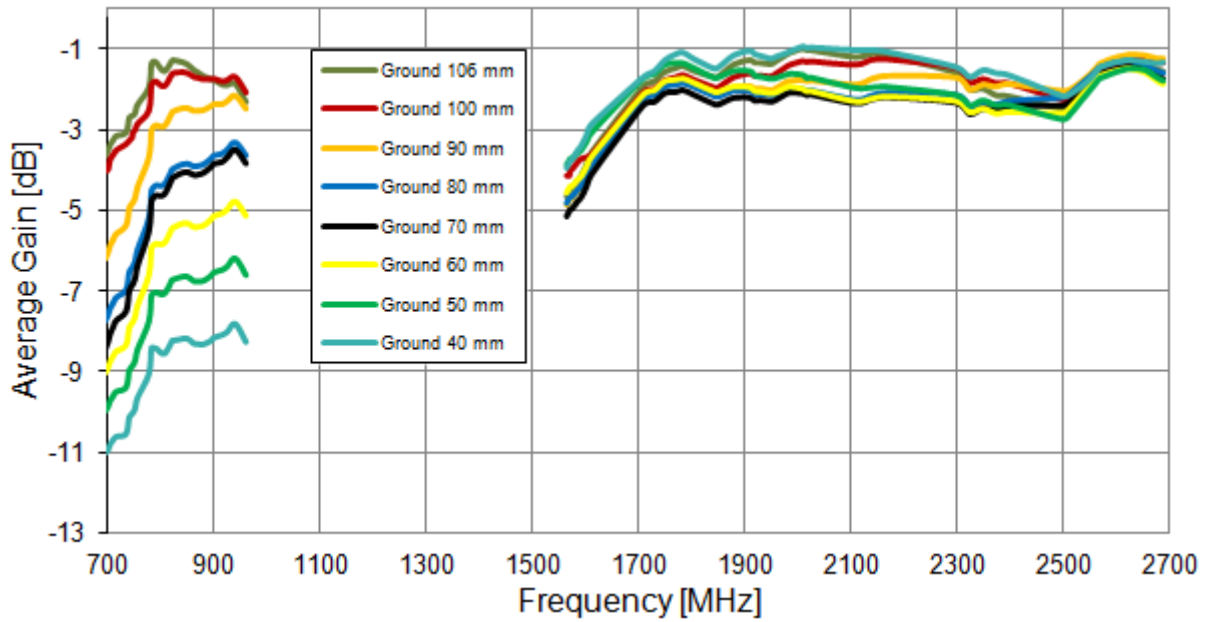

Figure 6. Average Gain of the Warrior PA710 LTE antenna

4.6. 3D Radiation Pattern (measured on 120*45mm EVB)

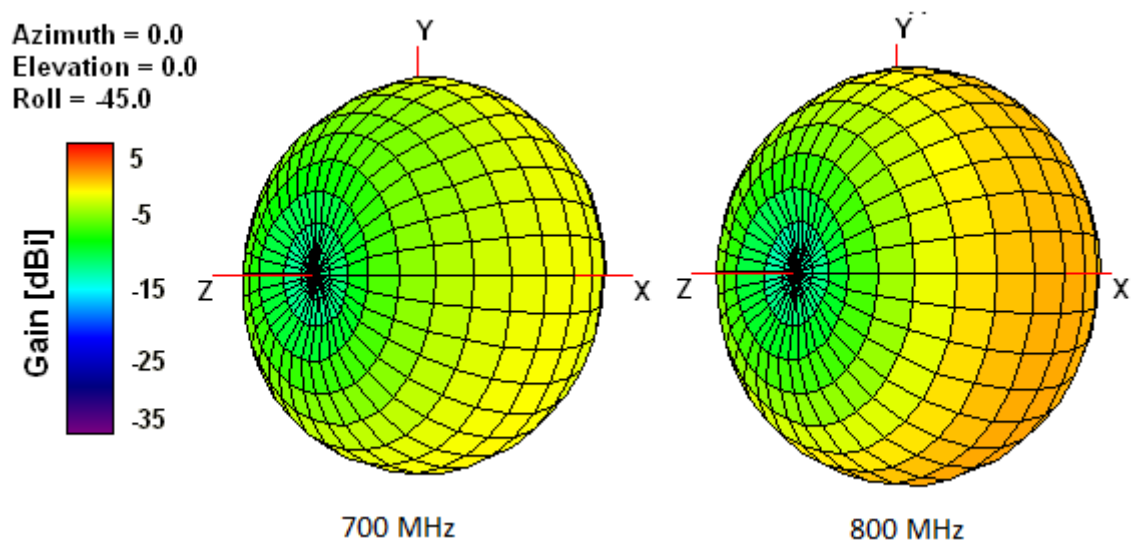

Figure 7. 3D Radiation Pattern at 700 and 800 MHz of the Warrior PA710 Antenna

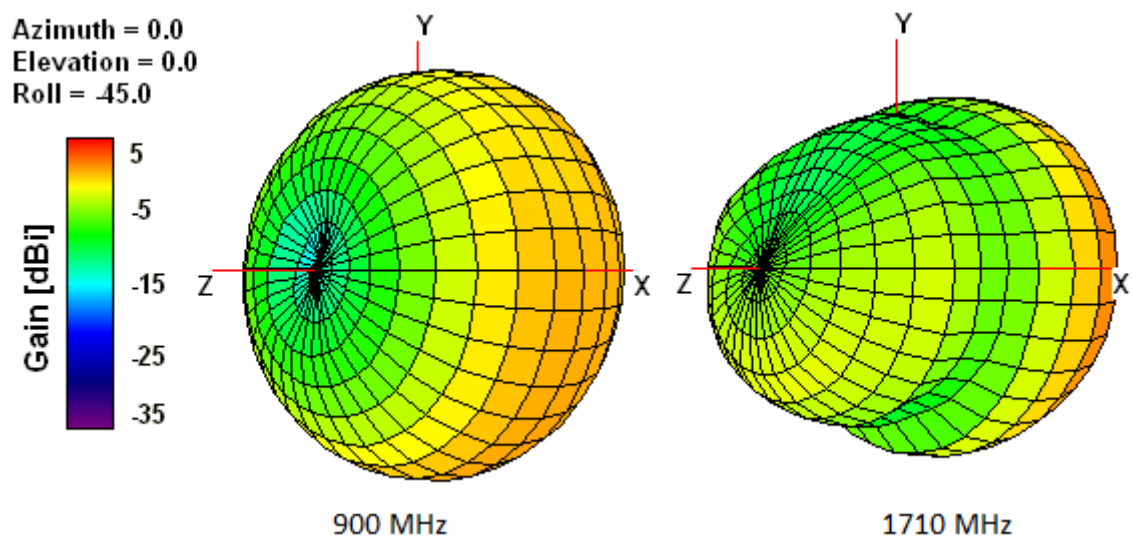

Figure 8. 3D Radiation Pattern at 900 and 1700 MHz of the Warrior PA710 Antenna

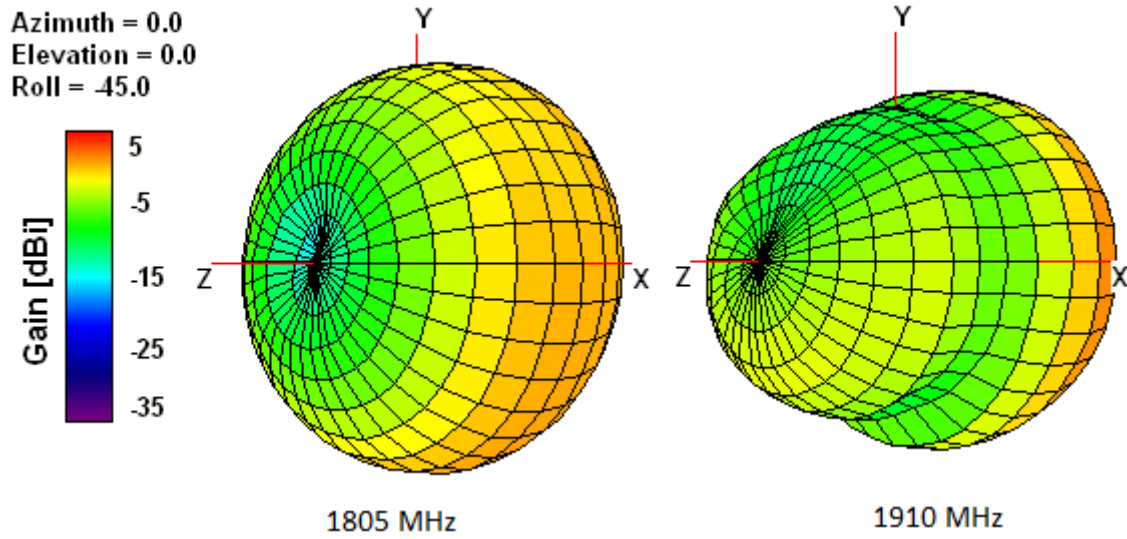

Figure 9. 3D Radiation Pattern at 1805 and 1910 MHz of the Warrior PA710 Antenna

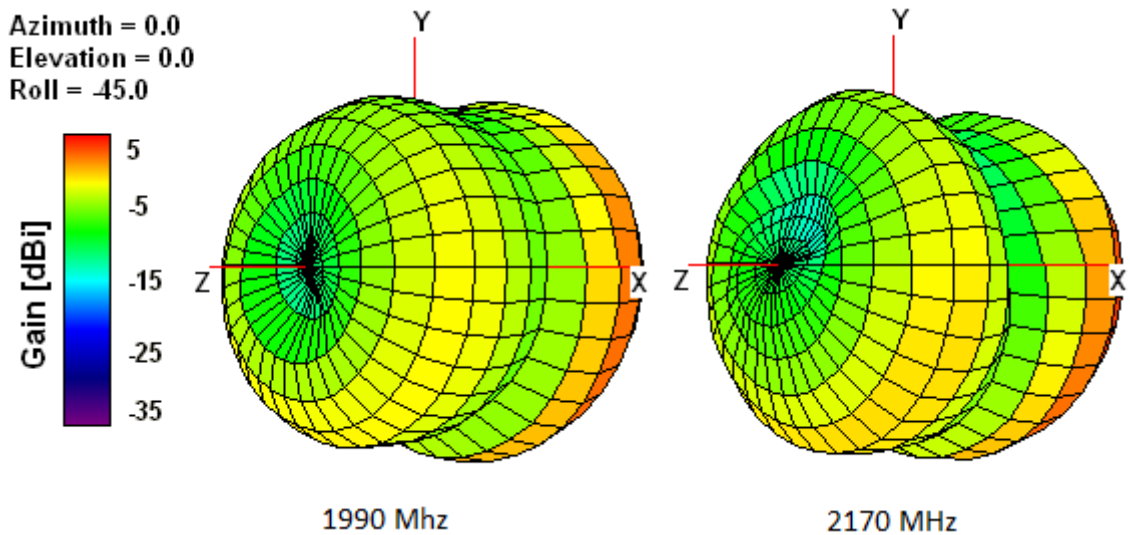

Figure 10. 3D Radiation Pattern at 1990 and 2170 MHz of the Warrior PA710 Antenna

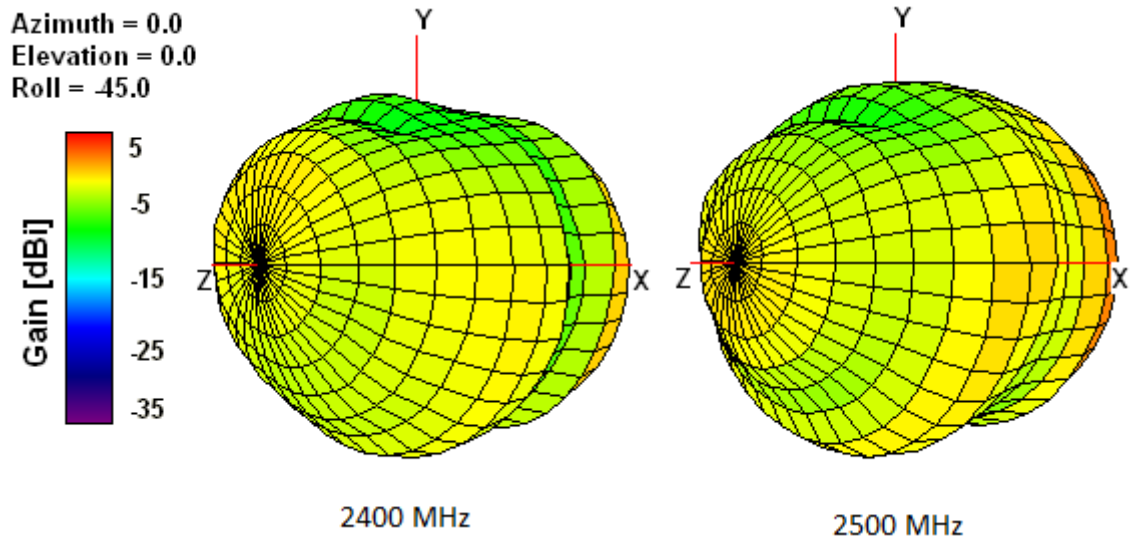

Figure 11. 3D Radiation Pattern at 2500 and 2600 MHz of the Warrior PA710 Antenna

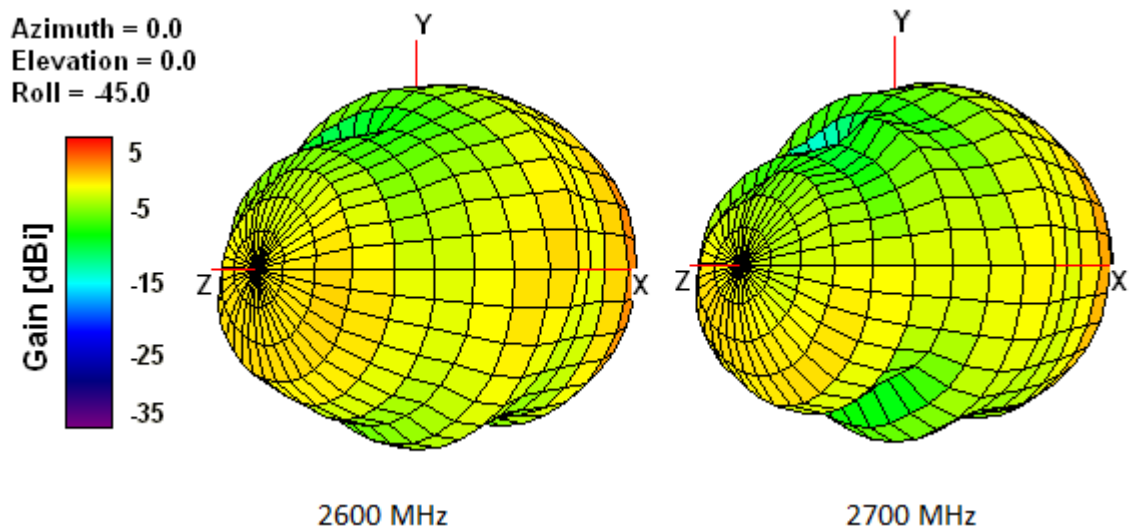

Figure 12. 3D Radiation Pattern at 2700 and 2800 MHz of the Warrior PA710 Antenna

4.7. 2D Radiation Pattern (measured on 120*45mm EVB)

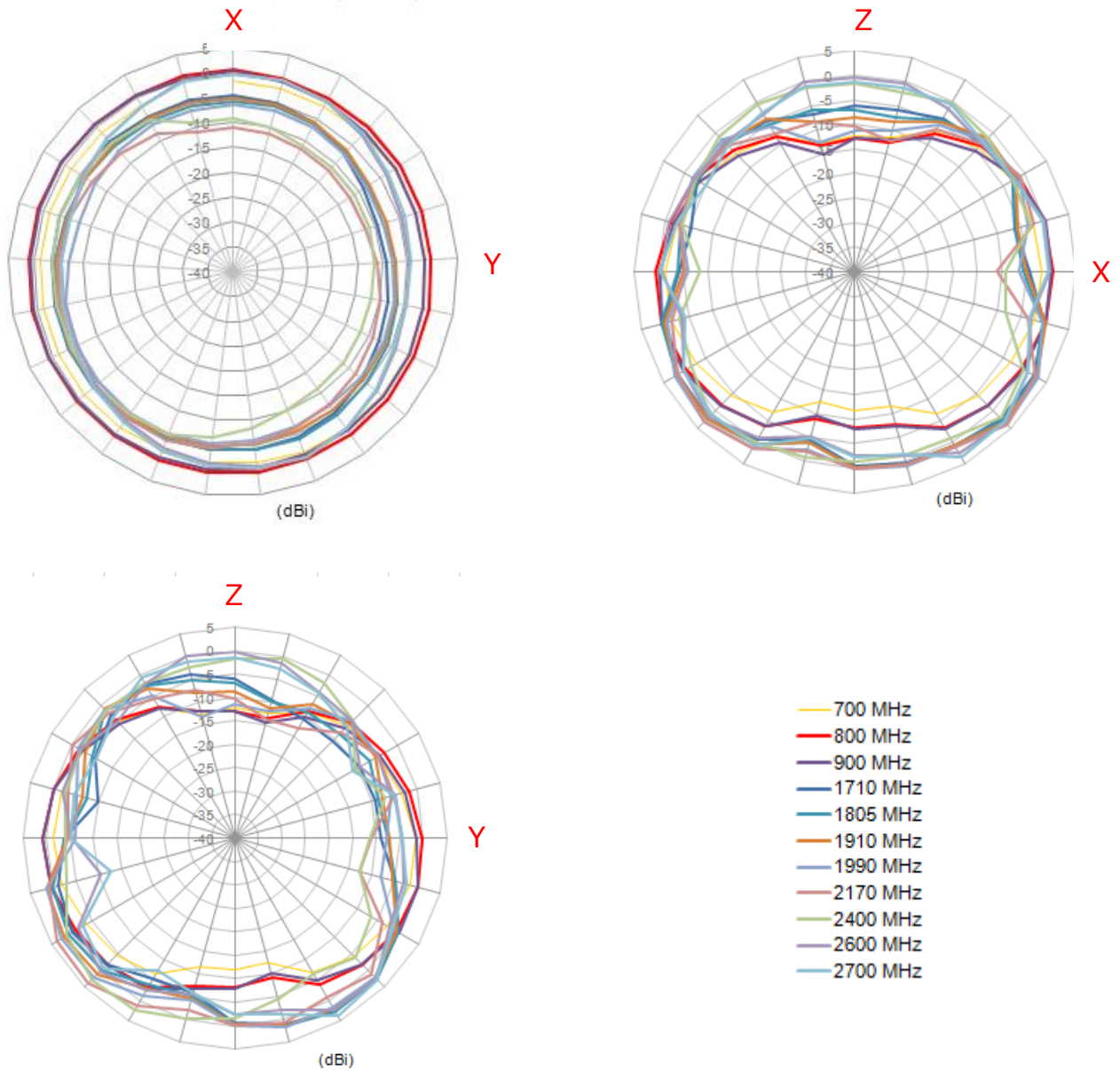

Figure 13. 2D Radiation Pattern of the Warrior PA710 Antenna

5. Mechanical Drawings (Unit: mm)

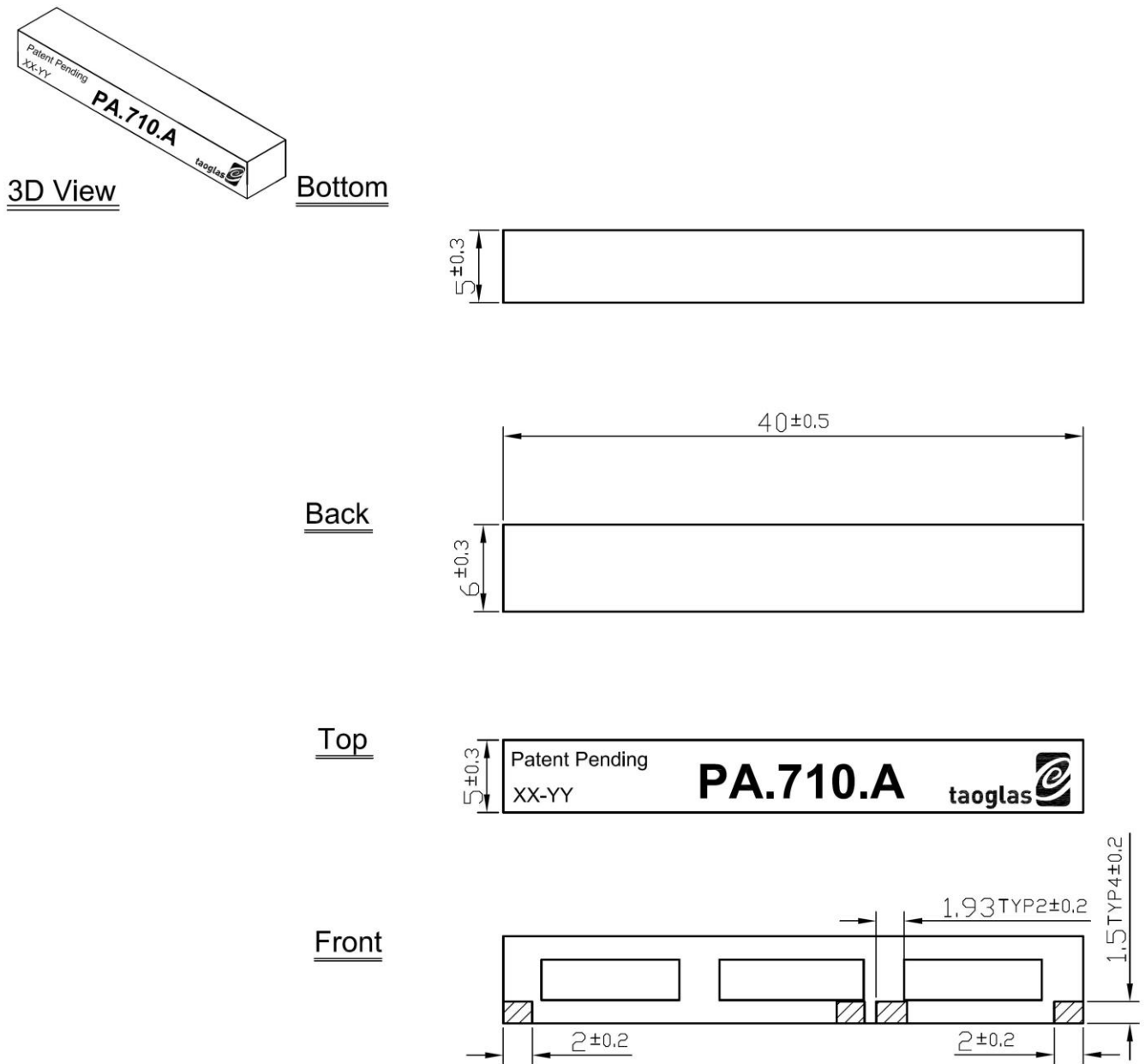

Figure 14. Mechanical Drawing of the Warrior PA710 Antenna.

6. Layout Dimensions (Unit: mm)

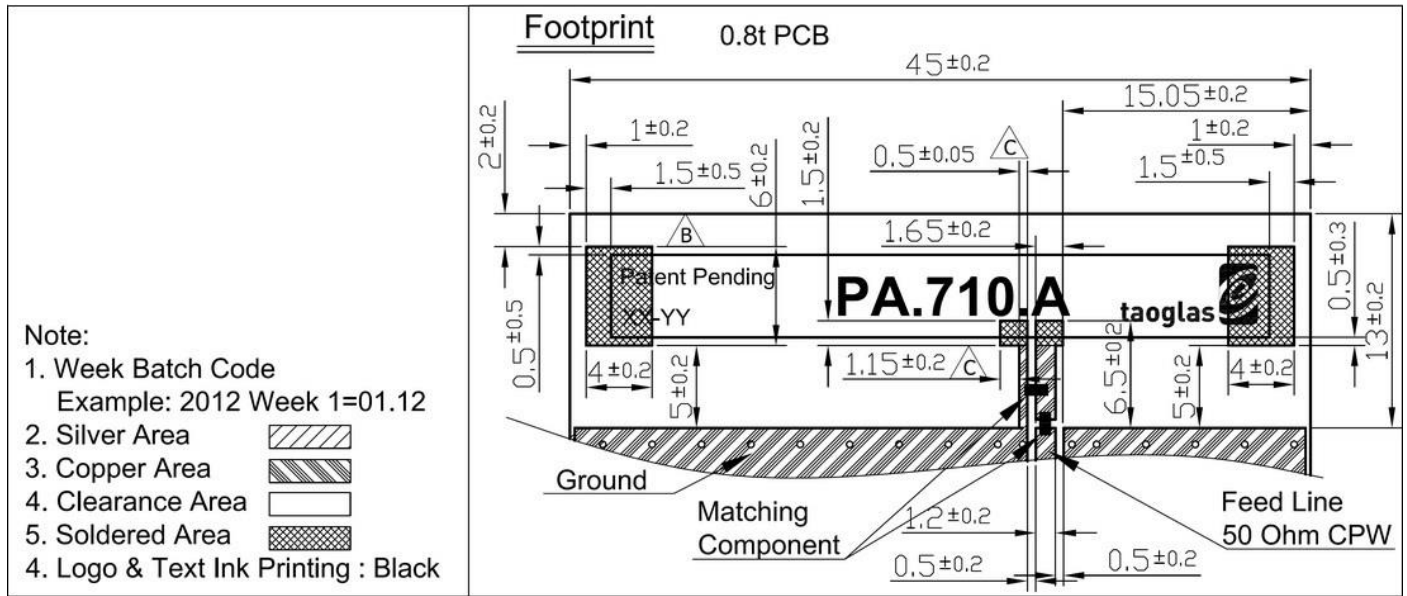

Figure 15. Layout dimensions of the Warrior PA.710.A Antenna.

7. EVB Dimension (Unit: mm)

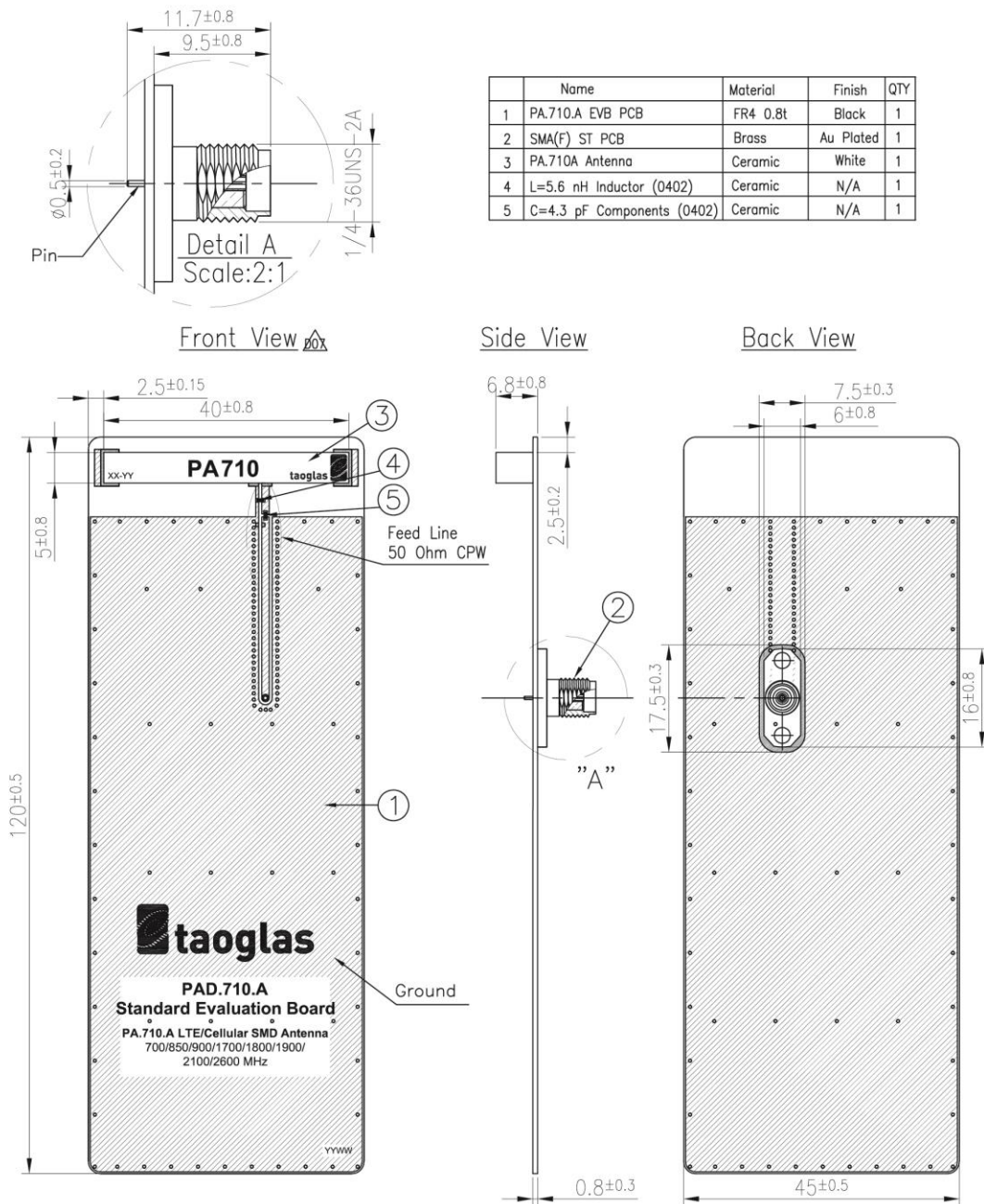
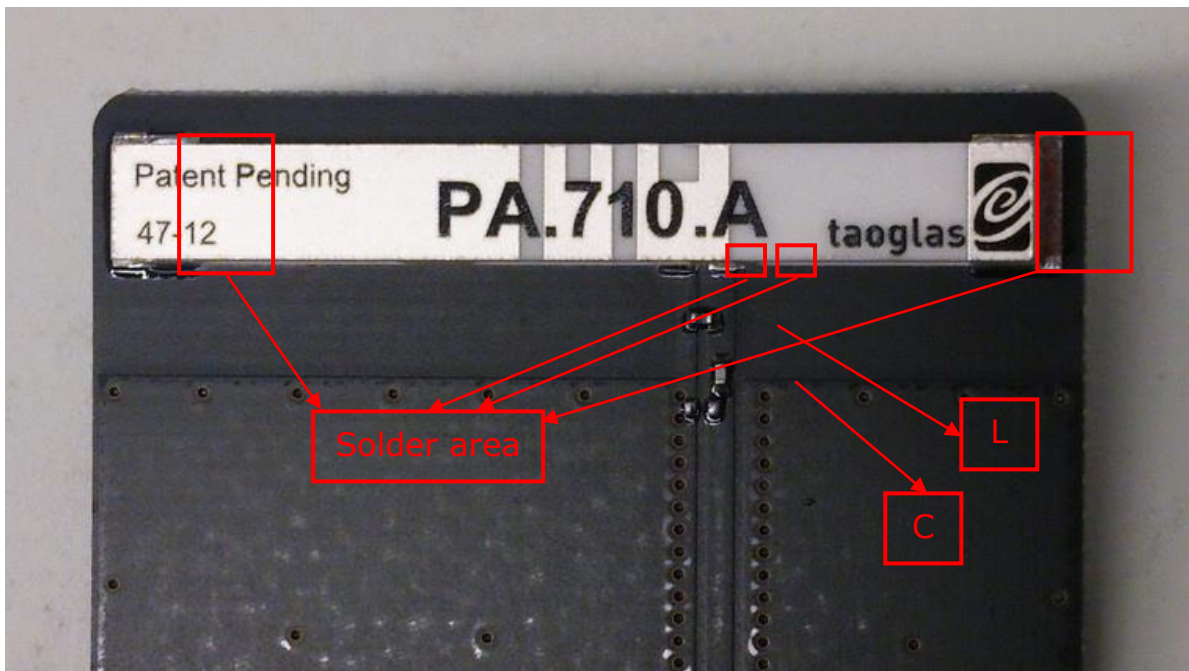
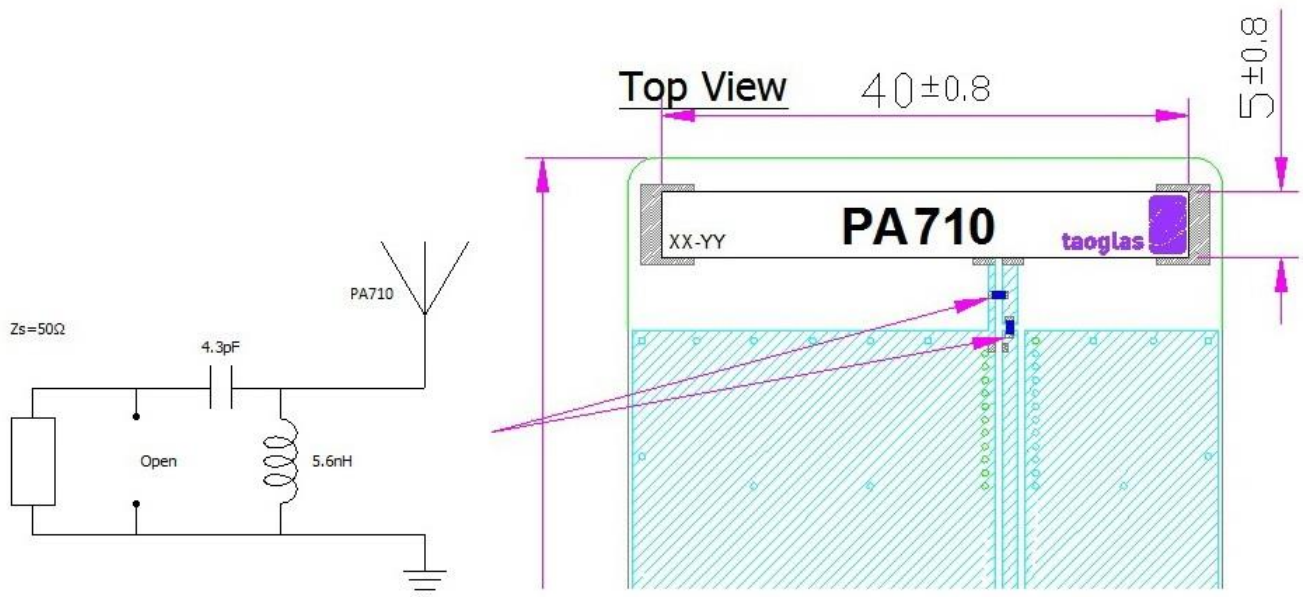

Figure 16. EVB Dimensions of the Warrior PA.710.A

8. Matching Circuit (Unit: mm)



Circuit Symbol	Size	Description
L1	0402	5.6nH inductor (LQG15HS5N6S02D)
C1	0402	4.3pF Capacitor (GRM1555C1H4R3CA01D)

Figure 17. Recommended matching circuit

9. Packaging (Unit: mm)

PA.710.A

Packaging Specifications (1/2)

450 pc PA.710.A
 1 reel per small inner box
 Dimensions - 330*50mm
 Weight - 2.1kg

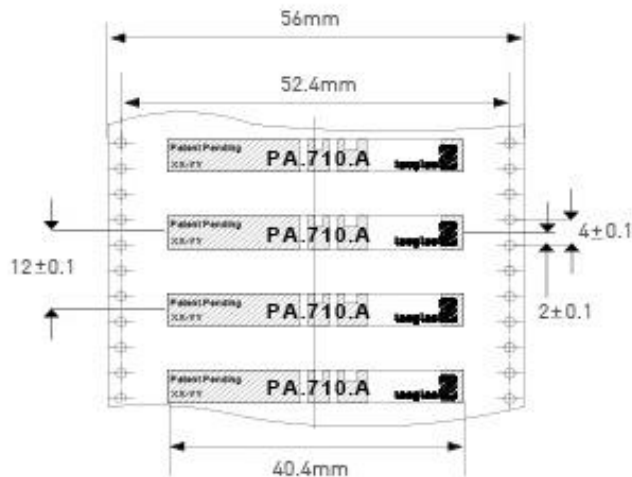
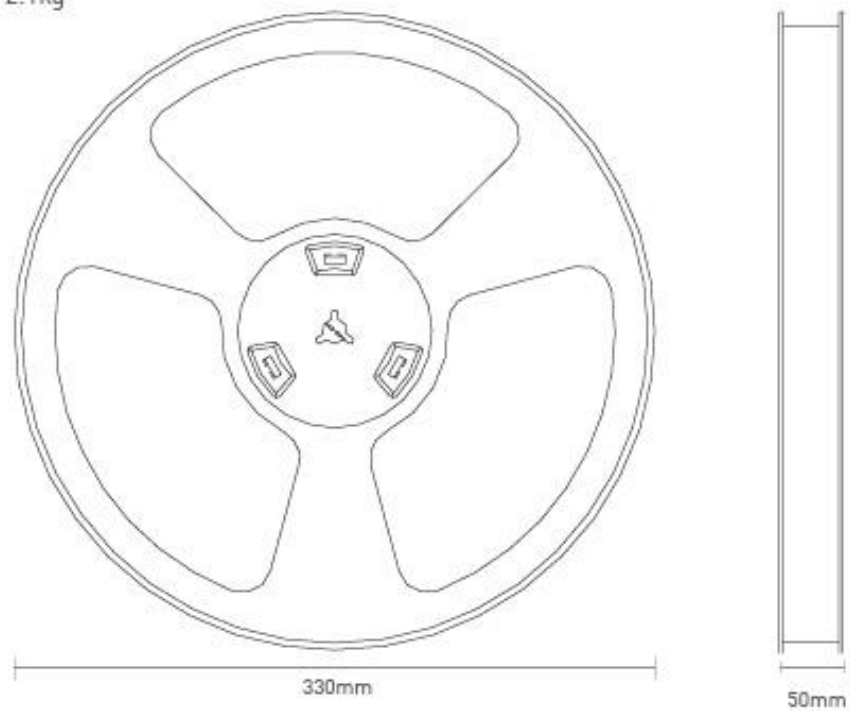

450 pc PA.710.A
1 reel in small inner box
Dimensions - 350*350*70
Weight - 2.4Kg

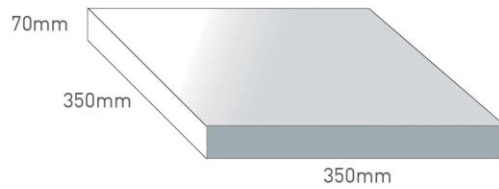

3 boxes / 1350 pcs in one carton
Carton Dimensions - 370*360*275
Weight - 8.1Kg

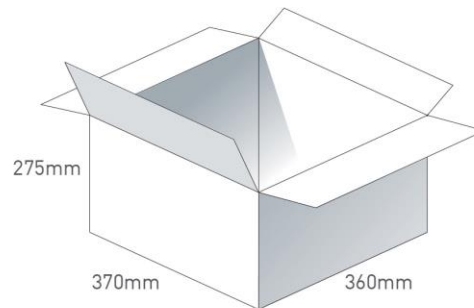

Pallet Dimensions 1110mm*1320mm*1100mm
36 Cartons per Pallet
9 Cartons per layer
4 Layers

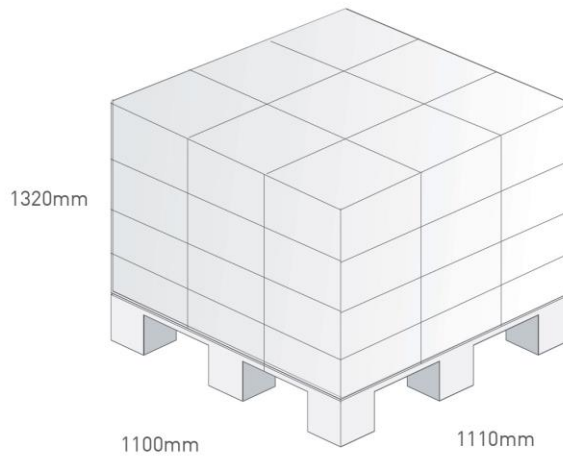

10. Recommended Reflow Temperature

PA.710 can be assembled following either Sn-Pb or Pb-Free assembly processes. The recommended soldering temperatures are as follows:

Phase	Profile Features	Sn-Pb Assembly	Pb-Free Assembly (SnAgCu)
Ramp-Up	Avg. Ramp-Up Rate (T _{smax} to T _P)	3°C/second (max)	3°C/second (max)
Preheat	Temperature Min (T _{smin})	100°	100°
	Temperature Max (T _{smax})	150°	150°
	Time (t _{smin} to t _{smax})	60-120 seconds	60-120 seconds
Reflow	Temperature (T _L)	183°C	217°C
	Total Time Above T _L b(T _L)	60-150 seconds	60-150 seconds
Peak	Temperature (T _P)	235°C	260°C
	Time (t _p)	10-30 seconds	20-40 seconds
Ramp-Down	Rate	6°C/second (max)	6°C/second (max)
Time from 25°C to peak Temperature		6 minutes max	8 minutes max

Temperature profile – (green area) for the assembly process in reflow ovens

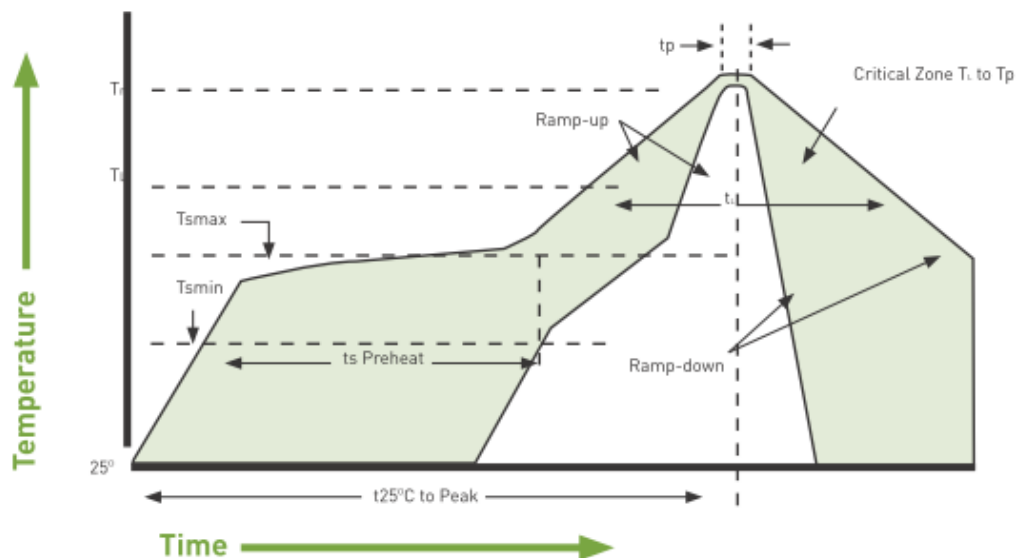

Figure 18. Temperature profile for the assembly process in reflow ovens



Taoglas makes no warranties based on the accuracy or completeness of the contents of this document and reserves the right to make changes to specifications and product descriptions at any time without notice. Taoglas reserves all rights to this document and the information contained herein.

Reproduction, use or disclosure to third parties without express permission is strictly prohibited.

Copyright © Taoglas Ltd.