

VGY-8026 Gyrotron Oscillator

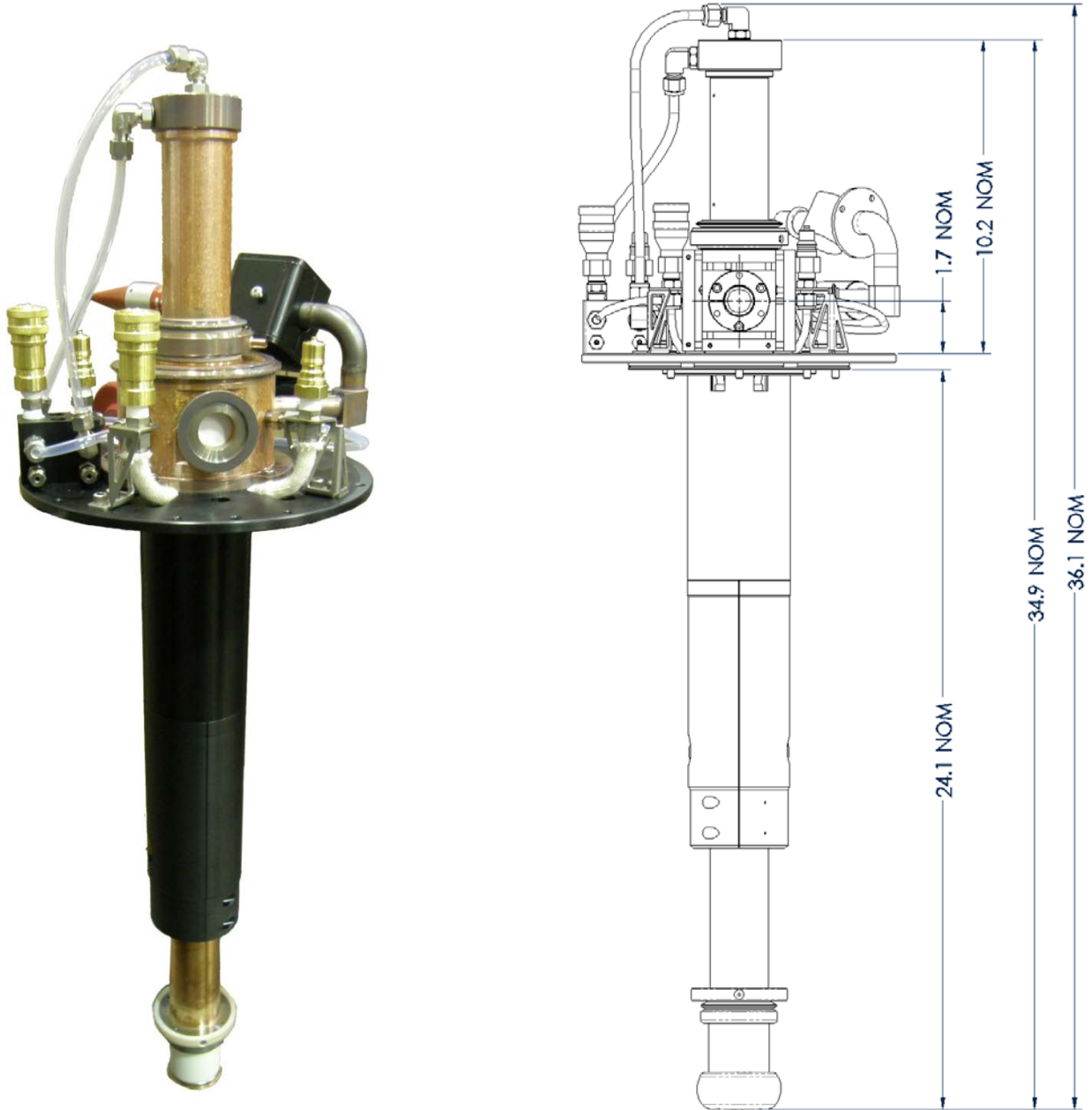

CPI-MPP provides an extensive line of gyrotrons that generate frequencies from 28 to 263 GHz with power levels ranging from 25 W to 1.4 MW. High power, long-pulse/CW gyrotrons are employed primarily for fusion plasma heating and current-drive. Lower-power devices are employed for a wide variety of scientific, industrial, and defense applications.

The VGY-8026 gyrotron delivers 25 W of continuous output power at a frequency of 263 GHz, and allows for frequency tuning of ± 50 MHz relative to the nominal center frequency.



For additional information on gyrotrons, other CPI products, or a copy of our catalog-on-disk, please contact:
CPI Microwave Power Products, 811 Hansen Way, Palo Alto, CA 94303-0750
Telephone: 650-846-3172, Fax: 650-856-0705, Email: marketing@cpil.com

VGY-8026 Gyrotron Oscillator



Output Power vs. Cathode Voltage

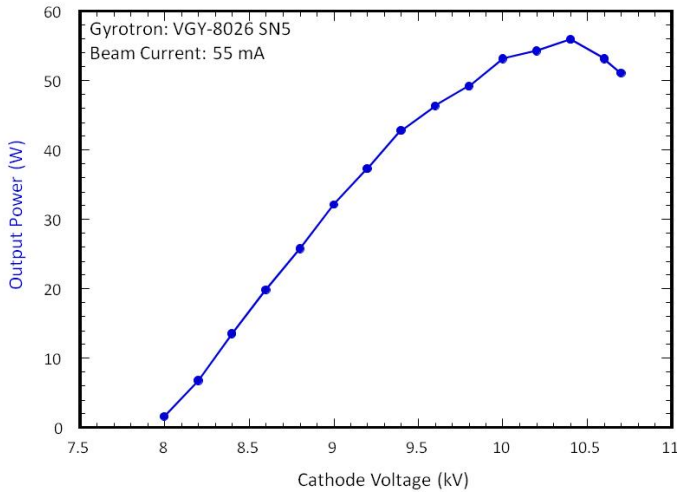

Output Power vs. Beam Current

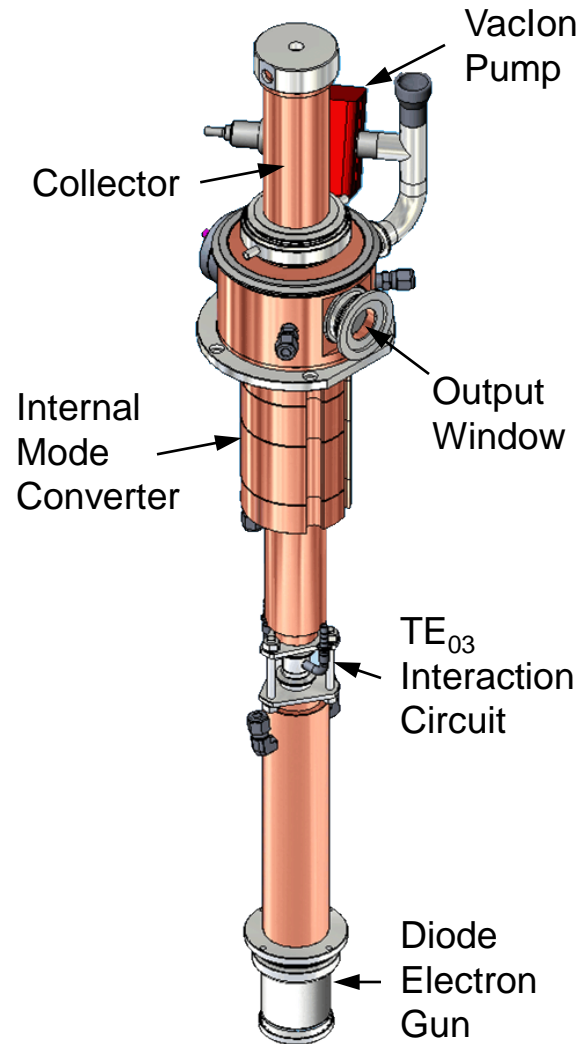
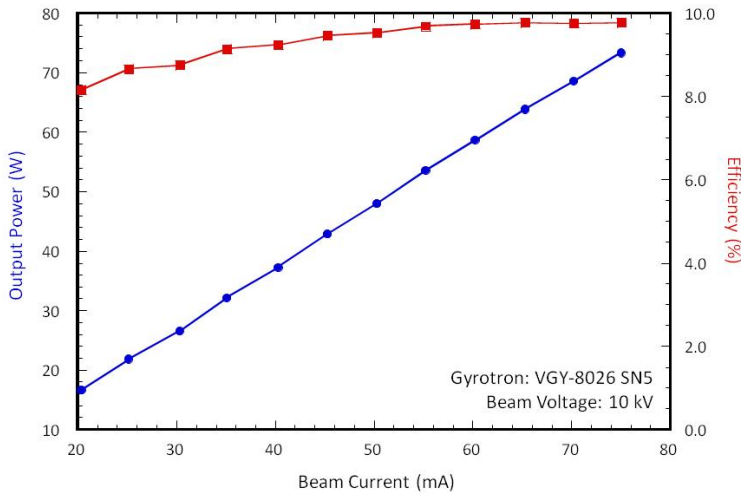

Features

- Continuous wave (CW) operation
- Stable output power and frequency (requires suitable control system)
- ± 50 MHz frequency tuning
- Diode electron gun
- Operates in a 10 Tesla superconducting magnet with a $\text{\O}3.5''$ (89mm) warm bore

Typical Operating Parameters

Power Output	> 25 W
Pulse Length	CW
Cath. Voltage (Nom.)	10-15 kV
Cath. Voltage (Max)	25 kV
Beam Current (Nom.)	~50 mA
Beam Current (Max)	150 mA
Frequency	263 GHz
Efficiency	1-10%
Output Mode	TEM ₀₀

For additional information on gyrotrons, other CPI products, or a copy of our catalog-on-disk, please contact:
 CPI Microwave Power Products, 811 Hansen Way, Palo Alto, CA 94303-0750
 Telephone: 650-846-3172, Fax: 650-856-0705, Email: marketing@cpii.com