



Size: 2.0in x 1.0in x 0.4in (50.8mm x 25.4mm x 10.2mm)

OPTIONS

- Negative Logic Remote ON/OFF

FEATURES

- High Efficiency up to 89%
- Six-Sided Continuous Shielding
- 20 Watts Maximum Output Power
- 4:1 Ultra Wide Input Voltage Range
- Over Current, Over Voltage, Input Under Voltage, and Short Circuit Protection
- Standard 2.0" x 1.0" x 0.4" Package
- Compliant to RoHS II & REACH
- CE Marked
- UL60950-1, EN60950-1 & IEC60950-1 Safety Approvals
- Optional Negative Logic Remote ON/OFF
- Useful in Multiple Applications

APPLICATIONS

- Measurement
- Wireless Network
- Telecom/Datacom
- Industry Control System
- Semiconductor

DESCRIPTION

The MDW series consists of single output DC/DC converters that provides 20 watts of output power in a low profile 2 x 1 x 0.4 inch package. These converters feature a 4:1 wide input voltage range of 9-36VDC or 18-75VDC as well as positive or negative remote on/off, 1600VDC I/O isolation, trimmable output voltage, and six-sided shielding. These converters are also protected against over current, over voltage, input under voltage, and short circuit conditions. All models are particularly suited for telecommunications, industrial, mobile telecom, and test equipment applications.

MODEL SELECTION TABLE

Single Output

Model Number	Input Voltage Range	Output Voltage	Output Current		Ripple & Noise ⁽¹⁾	Input Current		Output Power	Maximum Capacitive Load ⁽⁴⁾	Efficiency ⁽¹⁾
			Min Load	Max Load		No Load ⁽²⁾	Full Load ⁽³⁾			
MDW24S3.3-5500	24VDC (9-36VDC)	3.3VDC	0mA	5500mA	60mVp-p	50mA	934mA	20W	18000µF	85%
MDW24S5-4000		5VDC	0mA	4000mA	75mVp-p	65mA	992mA		9600µF	88%
MDW24S12-1670		12VDC	0mA	1670mA	75mVp-p	22mA	1018mA		1650µF	86%
MDW24S15-1330		15VDC	0mA	1330mA	75mVp-p	22mA	1014mA		1050µF	86%
MDW48S3.3-5500	48VDC (18-75VDC)	3.3VDC	0mA	5500mA	60mVp-p	35mA	467mA	20W	18000µF	85%
MDW48S5-4000		5VDC	0mA	4000mA	75mVp-p	35mA	496mA		9600µF	88%
MDW48S12-1670		12VDC	0mA	1670mA	75mVp-p	15mA	503mA		1650µF	87%
MDW48S15-1330		15VDC	0mA	1330mA	75mVp-p	15mA	501mA		1050µF	87%

MODEL SELECTION TABLE

Dual Output

Model Number	Input Voltage Range	Output Voltage	Output Current		Ripple & Noise	Input Current		Output Power	Maximum Capacitive Load	Efficiency
			Min Load	Max Load		No Load	Full Load			
MDW24D5-2000	24VDC (9-36VDC)	±5 VDC	0mA	±2000mA	100mVp-p	55mA	992mA	20W	±4800uF	88%
MDW24D12-833		±12VDC	0mA	±833mA	100mVp-p	30mA	1004mA		±825uF	87%
MDW24D15-667		±15VDC	0mA	±667mA	100mVp-p	30mA	1005mA		±525uF	87%
MDW48D5-2000	48VDC (18-75VDC)	±5 VDC	0mA	±2000mA	100mVp-p	35mA	490mA	20W	±4800uF	89%
MDW48D12-833		±12VDC	0mA	±833mA	100mVp-p	17mA	496mA		±825uF	88%
MDW48D15-667		±15VDC	0mA	±667mA	100mVp-p	17mA	496mA		±525uF	88%

SPECIFICATIONS

All specifications are based on 25°C, Nominal Input Voltage, and Maximum Output Current unless otherwise noted.
We reserve the right to change specifications based on technological advances.

SPECIFICATION	TEST CONDITIONS		Min	Typ	Max	Unit
INPUT SPECIFICATIONS						
Operating Input Voltage Range	24V nominal input		9	24	36	VDC
	48V nominal input		18	48	75	
Start-Up Voltage	24V nominal input				9	VDC
	48V nominal input				18	
Shutdown Voltage	24V nominal input			7.5		VDC
	48V nominal input			15		
Input Surge Voltage (100ms max.)	24V nominal input				50	VDC
	48V nominal input				100	
Input Reflected Ripple Current				20		mAp-p
Input Filter			Pi Type			
OUTPUT SPECIFICATIONS						
Output Voltage			See Table			
Voltage Accuracy			-1.0		+1.0	%
Line Regulation	Low Line to High Line @Full Load	Single Outputs	-0.2		+0.2	%
		Dual Outputs	-0.5		+0.5	
Load Regulation	No Load to Full Load	Single Outputs	-0.5		+0.5	%
		Dual Outputs	-1.0		+1.0	
Voltage Adjustability	Single Outputs		-10		+10	%
Cross Regulation	Dual Outputs, Asymmetrical load 25%/100% FL		-5.0		+5.0	%
Output Power			See Table			
Output Current			See Table			
Minimum Load			0			A
Maximum Capacitive Load			See Table			
Ripple & Noise (20MHz bandwidth)	Measured with a 0.1µF/50V MLCC		See Table			
Transient Response Recovery Time	25% load step change			250		µs
Start-Up Time	Constant Resistive Load	Power Up		20		ms
		Remote ON/OFF		20		
Temperature Coefficient			-0.02		+0.02	%/°C
REMOTE ON/OFF CONTROL⁽⁵⁾						
Positive Logic (Standard)	DC-DC ON		Open or 3~12VDC			
	DC-DC OFF		Short or 0~1.2VDC			
Negative Logic (Option)	DC-DC ON		Short or 0~1.2VDC			
	DC-DC OFF		Open or 3~12VDC			
Input Current of CTRL Pin			-0.5		+0.5	mA
Remote OFF Input Current				2.5		mA
PROTECTION						
Short Circuit Protection			Continuous, Automatic Recovery			
Over Load Protection	% of Iout rated			150		%
	3.3V Outputs			3.9		
Over Voltage Protection (Zener Diode Clamp)	5V Outputs			6.2		V
	12V Outputs			15		
	15V Outputs			18		
ENVIRONMENTAL SPECIFICATIONS						
Operating Ambient Temperature	Without Derating		-40		+66	°C
	With Derating		+66		+105	
Storage Temperature			-55		+125	°C
Maximum Case Temperature					+105	°C
Relative Humidity			5		95	% RH
Thermal Shock			MIL-STD-810F			
Thermal Impedance ⁽⁶⁾	Vertical direction by natural convection (20LFM)	Without Heat-Sink		12		°C/W
		With Heat-Sink		10		
Vibration			MIL-STD-810F			
MTBF	MIL-HDBK-217F, Full Load			1,851,000		hours

SPECIFICATIONS

All specifications are based on 25°C, Nominal Input Voltage, and Maximum Output Current unless otherwise noted.
We reserve the right to change specifications based on technological advances.

SPECIFICATION	TEST CONDITIONS		Min	Typ	Max	Unit
GENERAL SPECIFICATIONS						
Efficiency			See Table			
Switching Frequency			360	400	440	kHz
Isolation Voltage	1 Minute	Input to Output	1600			VDC
		Input to Case	1600			
		Output to Case	1600			
Isolation Resistance	500VDC		1			GΩ
Isolation Capacitance					1500	pF
Case Grounding	Connect Case to -Vin with decoupling Y cap					
PHYSICAL SPECIFICATIONS						
Weight			0.95oz (27g)			
Dimensions (L x W x H)			2.0in x 1.0in x 0.40in (50.8mm x 25.4mm x 10.2mm)			
Case Material			Nickel-Coated Copper			
Base Material			FR4 PCB			
Potting Material			Epoxy (UL94 V-0)			
Shielding			Six-Sided			
SAFETY & EMC CHARACTERISTICS						
Safety Approvals			UL60950-1 EN60950-1 IEC60950-1			
EMI ⁽⁷⁾	EN55022					Class A Class B
ESD	EN61000-4-2	Air ±8kV Contact ±6kV				Perf. Criteria B
Radiated Immunity	EN61000-4-3	10 V/m				Perf. Criteria A
Fast Transient ⁽⁶⁾	EN61000-4-4	±2kV				Perf. Criteria B
Surge	EN61000-4-5	±1kV				Perf. Criteria A
Conducted Immunity	EN61000-4-6	10 Vr.m.s				Perf. Criteria A
Power Frequency Magnetic Field	EN61000-4-8	100A/m continuous; 1000A/m 1 sec				Perf. Criteria A

NOTES

- (1) Typical Value at Nominal Input Voltage and Full Load
- (2) Typical Value at Nominal Input Voltage and No Load
- (3) Maximum Value at Nominal Input and Full Load
- (4) Test by minimum Vin and Constant Resistive Load
- (5) The ON/OFF control pin voltage is referenced to -Vin.
To order negative logic ON/OFF control add the suffix "R" (Ex. MDW48S5-4000R)
- (6) Heat Sink is optional, consult factor for ordering details.
- (7) The MDW Series can meet EN55022 Class A with an external capacitor in parallel with the input pins.
Recommended: 24Vin: NA
48Vin: 1µF/100V
- (8) An external filter capacitor is required if the module has to meet EN61000-4-5.
The filter capacitor Wall Industries suggest: Nippon chemi-con KY series, 220µF/100V, ESR 48mΩ.

Due to advances in technology, specifications subject to change without notice.

DERATING CURVES

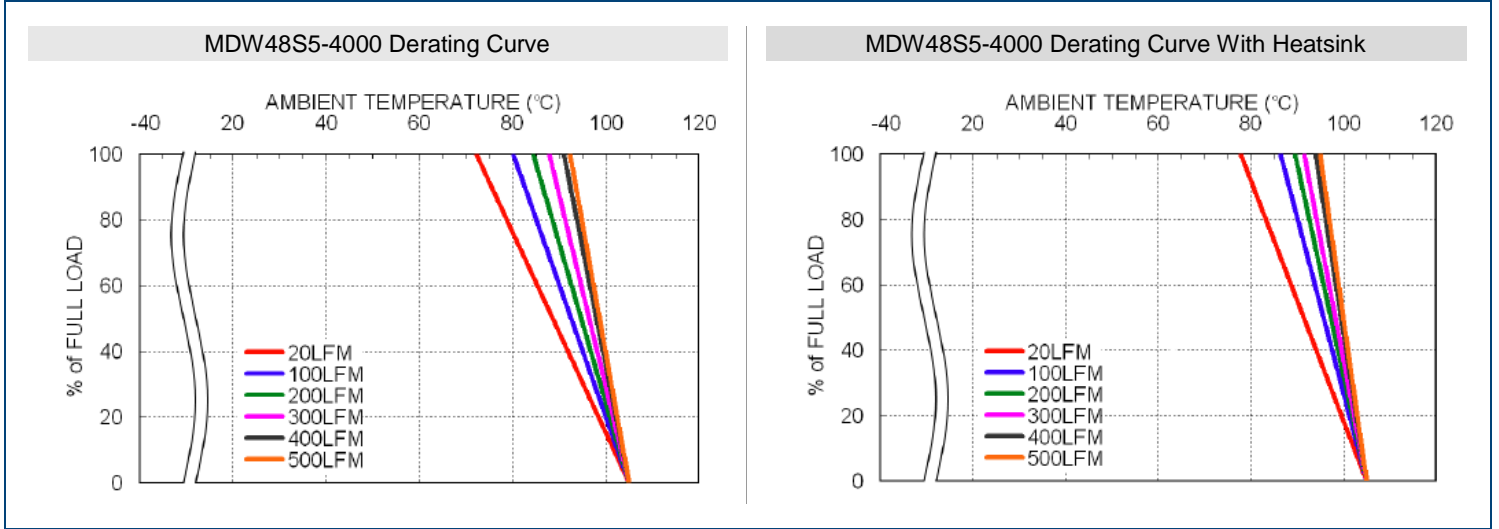

EFFICIENCY GRAPHS

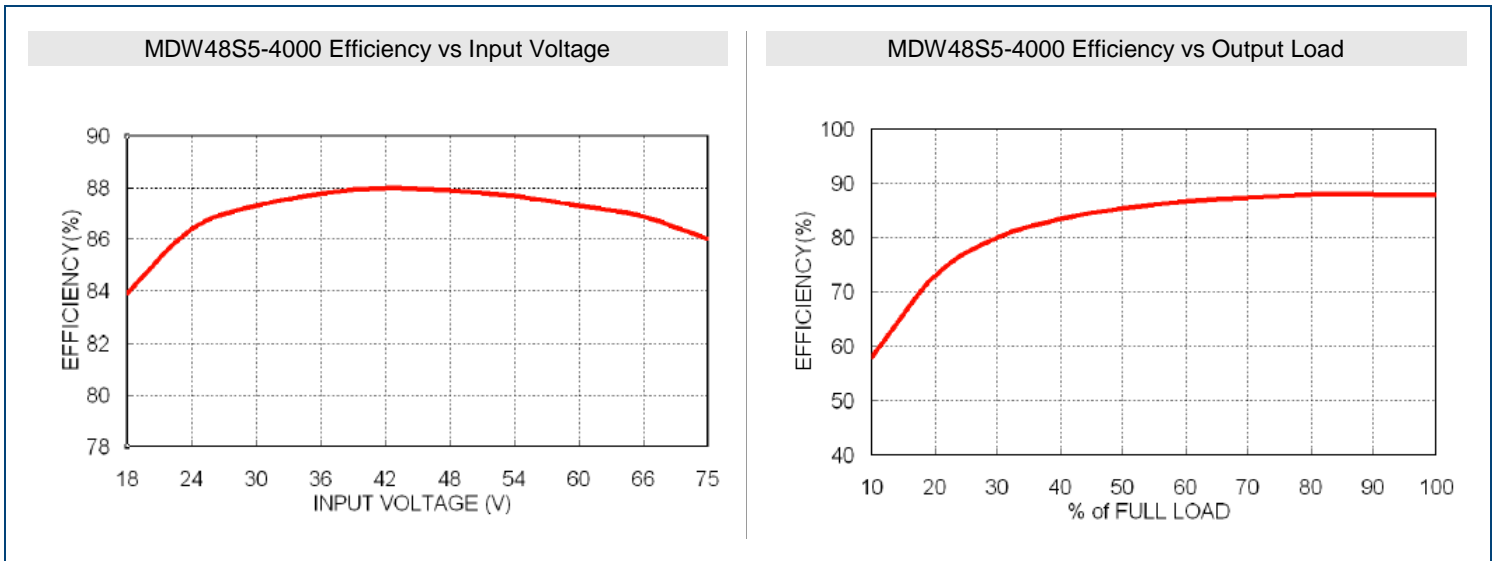

MECHANICAL DRAWINGS

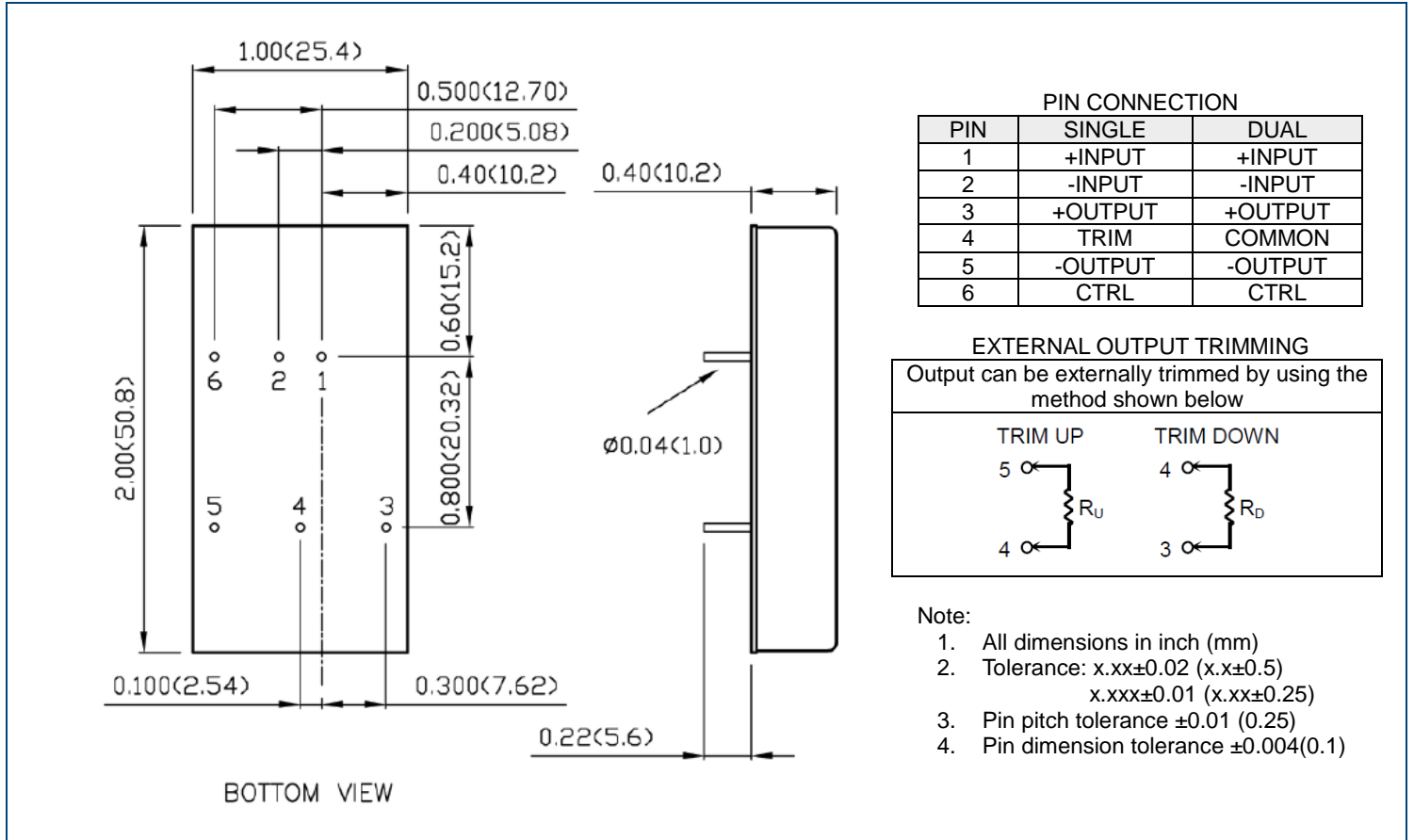

RECOMMENDED FILTER

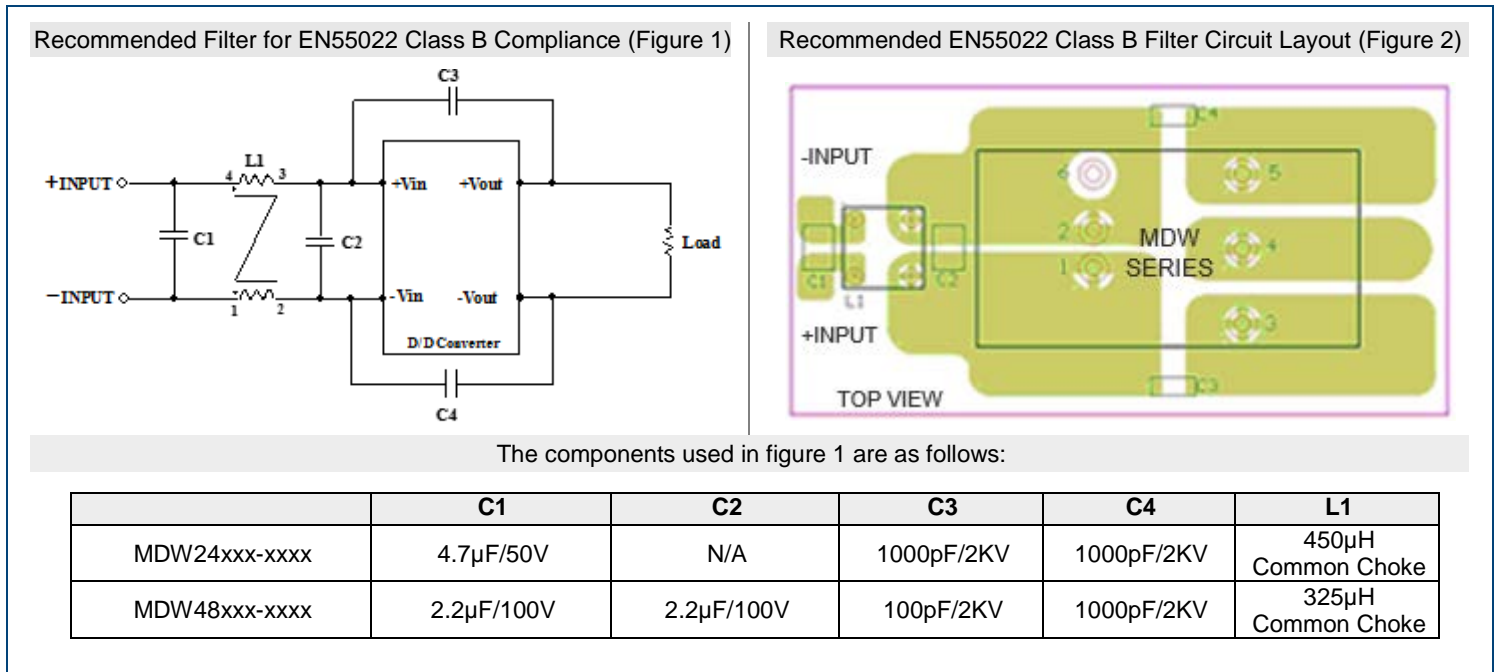

REMOTE ON/OFF CONTROL

The remote ON/OFF pin allows the user to turn the DC/DC power module on during a logic high and off during a logic low. Figure 3 gives several examples of acceptable configurations. The remote ON/OFF pin is an open collector/drain logic input signal (Von/off) that has -Vin as the reference voltage. If not using the remote on/off feature, open the circuit between the on/off pin and the -input pin to turn the module on.

REMOTE ON/OFF IMPLEMENTATION

Isolated-Closure Remote ON/OFF

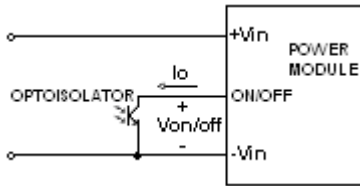

Level Control Using TTL Output

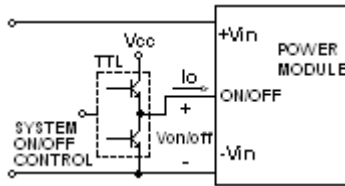

Level Control Using Line Voltage

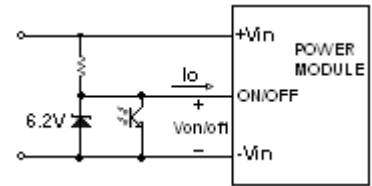

OUTPUT VOLTAGE ADJUSTMENT

Output voltage set point adjustment allows the user to increase or decrease the output voltage set point of a module. This is accomplished by connecting an external resistor between the TRIM pin and either the +Vout or -Vout pins. With an external resistor between the TRIM and -Vout pin, the output voltage set point increases. With an external resistor between the TRIM and +Vout pin, the output voltage set point decreases.

Figure 4

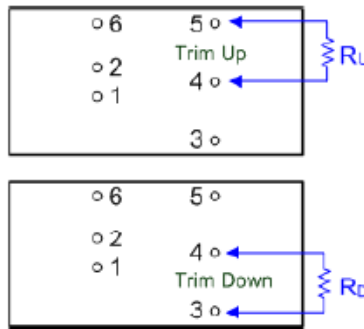

MDWxxS3.3-5500

Trim	Trim _{up}	R _{up}	Trim _{down}	R _{down}
1%	3.333V	57.930 kΩ	3.267V	69.470 kΩ
2%	3.366V	26.165 kΩ	3.234V	31.235 kΩ
3%	3.399V	15.577 kΩ	3.201V	18.490 kΩ
4%	3.432V	10.283 kΩ	3.168V	12.117 kΩ
5%	3.465V	7.106 kΩ	3.135V	8.294 kΩ
6%	3.498V	4.988 kΩ	3.102V	5.745 kΩ
7%	3.531V	3.476 kΩ	3.069V	3.924 kΩ
8%	3.564V	2.341 kΩ	3.036V	2.559 kΩ
9%	3.597V	1.459 kΩ	3.003V	1.497 kΩ
10%	3.630V	0.753 kΩ	2.970V	0.647 kΩ

MDWxxS5-4000

Trim	Trim _{up}	R _{up}	Trim _{down}	R _{down}
1%	5.050V	36.570 kΩ	4.950V	45.533 kΩ
2%	5.100V	16.580 kΩ	4.900V	20.612 kΩ
3%	5.150V	9.917 kΩ	4.850V	12.306 kΩ
4%	5.200V	6.585 kΩ	4.800V	8.152 kΩ
5%	5.250V	4.586 kΩ	4.750V	5.660 kΩ
6%	5.300V	3.253 kΩ	4.700V	3.999 kΩ
7%	5.350V	2.302 kΩ	4.650V	2.812 kΩ
8%	5.400V	1.588 kΩ	4.600V	1.922 kΩ
9%	5.450V	1.032 kΩ	4.550V	1.230 kΩ
10%	5.500V	0.588 kΩ	4.500V	0.676 kΩ

MDWxxS12-1670

Trim	Trim _{up}	R _{up}	Trim _{down}	R _{down}
1%	12.120V	367.908 kΩ	11.880V	460.992 kΩ
2%	12.240V	165.954 kΩ	11.760V	207.946 kΩ
3%	12.360V	98.636 kΩ	11.640V	123.597 kΩ
4%	12.480V	64.977 kΩ	11.520V	81.423 kΩ
5%	12.600V	44.782 kΩ	11.400V	56.118 kΩ
6%	12.720V	31.318 kΩ	11.280V	39.249 kΩ
7%	12.840V	21.701 kΩ	11.160V	27.199 kΩ
8%	12.960V	14.488 kΩ	11.040V	18.162 kΩ
9%	13.080V	8.879 kΩ	10.920V	11.132 kΩ
10%	13.200V	4.391 kΩ	10.800V	5.509 kΩ

MDWxxS15-1330

Trim	Trim _{up}	R _{up}	Trim _{down}	R _{down}
1%	15.150V	404.184 kΩ	14.850V	499.816 kΩ
2%	15.300V	180.592 kΩ	14.700V	223.408 kΩ
3%	15.450V	106.061 kΩ	14.550V	131.272 kΩ
4%	15.600V	68.796 kΩ	14.400V	85.204 kΩ
5%	15.750V	46.437 kΩ	14.250V	57.563 kΩ
6%	15.900V	31.531 kΩ	14.100V	39.136 kΩ
7%	16.050V	20.883 kΩ	13.950V	25.974 kΩ
8%	16.200V	12.898 kΩ	13.800V	16.102 kΩ
9%	16.350V	6.687 kΩ	13.650V	8.424 kΩ
10%	16.500V	1.718 kΩ	13.500V	2.282 kΩ

MDWxxD5-2000

Trim	Trim _{up}	R _{up}	Trim _{down}	R _{down}
1%	10.1V	90.303 kΩ	9.9V	109.3 kΩ
2%	10.2V	40.602 kΩ	9.8V	48.998 kΩ
3%	10.3V	24.034 kΩ	9.7V	28.899 kΩ
4%	10.4V	15.751 kΩ	9.6V	18.849 kΩ
5%	10.5V	10.781 kΩ	9.5V	12.819 kΩ
6%	10.6V	7.467 kΩ	9.4V	8.799 kΩ
7%	10.7V	5.1 kΩ	9.3V	5.928 kΩ
8%	10.8V	3.325 kΩ	9.2V	3.775 kΩ
9%	10.9V	1.945 kΩ	9.1V	2.1 kΩ
10%	11V	0.84 kΩ	9V	0.76 kΩ

MDWxxD12-833

Trim	Trim _{up}	R _{up}	Trim _{down}	R _{down}
1%	24.24V	218.21 kΩ	23.76V	273.44 kΩ
2%	24.48V	98.105 kΩ	23.52V	123.02 kΩ
3%	24.72V	58.07 kΩ	23.28V	72.874 kΩ
4%	24.96V	38.052 kΩ	23.04V	47.803 kΩ
5%	25.2V	26.042 kΩ	22.8V	32.76 kΩ
6%	25.44V	18.035 kΩ	22.56V	22.732 kΩ
7%	25.68V	12.316 kΩ	22.32V	15.568 kΩ
8%	25.92V	8.026 kΩ	22.08V	10.196 kΩ
9%	26.16V	4.69 kΩ	21.84V	6.017 kΩ
10%	26.4V	2.021 kΩ	21.6V	2.675 kΩ

MDWxxD15-667

Trim	Trim _{up}	R _{up}	Trim _{down}	R _{down}
1%	30.3V	268.29 kΩ	29.7V	337.71 kΩ
2%	30.6V	120.64 kΩ	29.4V	152.02 kΩ
3%	30.9V	71.429 kΩ	29.1V	90.126 kΩ
4%	31.2V	46.822 kΩ	28.8V	59.178 kΩ
5%	31.5V	32.058 kΩ	28.5V	40.609 kΩ
6%	31.8V	22.215 kΩ	28.2V	28.23 kΩ
7%	32.1V	15.184 kΩ	27.9V	19.387 kΩ
8%	32.4V	9.911 kΩ	27.6V	12.756 kΩ
9%	32.7V	5.81 kΩ	27.3V	7.598 kΩ
10%	33V	2.529 kΩ	27V	3.471 kΩ

COMPANY INFORMATION

Wall Industries, Inc. has created custom and modified units for over 50 years. Our in-house research and development engineers will provide a solution that exceeds your performance requirements on-time and on budget. Our ISO9001-2008 certification is just one example of our commitment to producing a high quality, well-documented product for our customers.

Our past projects demonstrate our commitment to you, our customer. Wall Industries, Inc. has a reputation for working closely with its customers to ensure each solution meets or exceeds form, fit and function requirements. We will continue to provide ongoing support for your project above and beyond the design and production phases. Give us a call today to discuss your future projects.

Contact **Wall Industries** for further information:

Phone: ☎ (603)778-2300
Toll Free: ☎ (888)597-9255
Fax: ☎ (603)778-9797
E-mail: sales@wallindustries.com
Web: www.wallindustries.com
Address: 37 Industrial Drive
Exeter, NH 03833