

Voltage Controlled Oscillator

ZX95-4000R+

50Ω 3850 to 4000 MHz

The Big Deal:

- Good Harmonic Suppression
- Low Phase Noise
- Robust design and construction
- Rigid unibody construction



CASE STYLE: GB956

Product Overview:

The ZX95-4000R+ is a Voltage Controlled Oscillator, designed to operate from 3850 to 4000 MHz for WiMAX applications. The ZX95-4000R+ is built using Mini-Circuits proven unibody construction (size of 1.20" x .75" x .46") which integrates the RF connectors with the case body to shield against unwanted signals and noise.

Key Features

Feature	Advantages
Good Harmonic Suppression, -26 dBc typ.	Provides clear signals suitable for systems requiring high spectral purity.
Low Phase Noise: -99 dBc/Hz typ at 10 kHz offset	Low phase noise improves system EVM (Error Vector Magnitude).
Good Pushing, 1.5 MHz/V typ.	Provides increased immunity against noisy DC lines and improves output frequency stability vs. variations in supply voltage.
Robust design and construction	Each internal component of the ZX95-4000R+ is bonded to the substrate, providing better immunity to microphonics and reduced phase hit.

Coaxial

Voltage Controlled Oscillator

ZX95-4000R+

Low Noise 3850 to 4000 MHz

Features

- low phase noise, -99 dBc/Hz typ. @ 10kHz offset
- low harmonics, -26 dBc typ
- low pushing, 1.5 MHz/V typ.
- protected by US patent 6,790,049



CASE STYLE: GB956

Connectors	Model
SMA	ZX95-4000R-S+

Applications

- r & d
- lab
- instrumentation
- wireless communications
- WiMAX

+RoHS Compliant

The +Suffix identifies RoHS Compliance. See our web site for RoHS Compliance methodologies and qualifications

Electrical Specifications

MODEL NO.	FREQ. (MHz)		POWER OUTPUT (dBm)	PHASE NOISE dBc/Hz SSB at offset frequencies, kHz				TUNING					NON HARMONIC SPURIOUS (dBc)		HARMONICS (dBc)		PULLING pk-pk @12 dB (MHz)	PUSHING (MHz/V)	DC OPERATING POWER				
	Min.	Max.		Typ.	1	10	100	1000	VOLTAGE RANGE (V)		SENSI- TIVITY (MHz/V)	PORT CAP (pF)	3 dB MODULATION BANDWIDTH (MHz)	Typ.	Typ.	Typ.			Max.	Typ.	Max.	Vcc	Current (mA)
									Min.	Max.													
ZX95-4000R+	3850	4000	+5	-74	-99	-120	-140	0.5	10.0	24	-36	20	13	-90	-26	-16	5	1.5	5	42			

Maximum Ratings

Operating Temperature	-55°C to 85°C
Storage Temperature	-55°C to 100°C
Absolute Max. Supply Voltage (Vcc)	6.5V
Absolute Max. Tuning Voltage (Vtune)	12V
All specifications	50 ohm system

Permanent damage may occur if any of these limits are exceeded.



NOTE: When soldering the DC connections, caution must be used to avoid overheating the DC terminals. See Application Note [AN-40-10](#).

Outline Drawing

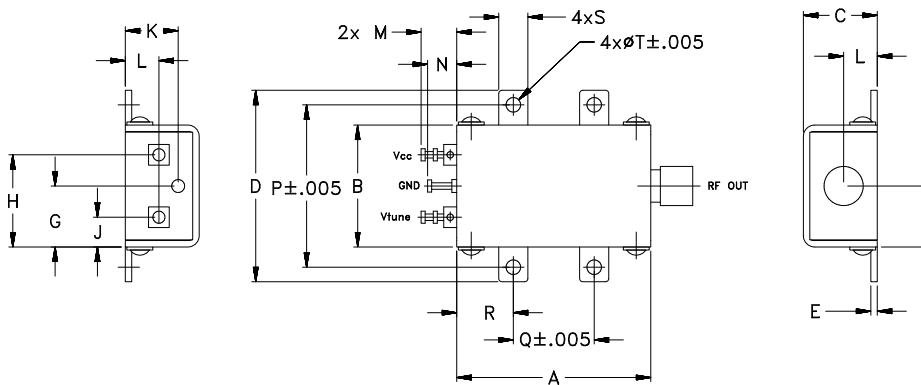

Outline Dimensions (inch/mm)

A	B	C	D	E	F	G	H	J	K	L	M	N	P	Q	R	S	T	wt.
1.20	.75	.46	1.18	.04	.38	.38	.57	.18	.33	.21	.22	.18	1.00	.50	.35	.18	.106	grams
30.48	19.05	11.68	29.97	1.02	9.65	9.65	14.48	4.57	8.38	5.33	5.59	4.57	25.40	12.70	8.89	4.57	2.69	35.0

Performance Data & Curves*

ZX95-4000R+

V TUNE	TUNE SENS (MHz/V)	FREQUENCY (MHz)			POWER OUTPUT (dBm)			Icc (mA)	HARMONICS (dBc)			FREQ. PUSH (MHz/V)	FREQ. PULL (MHz)	PHASE NOISE (dBc/Hz) at offsets				FREQ OFFSET (kHz)	PHASE NOISE at 3925 MHz (dBc/Hz)
		-55°C	+25°C	+85°C	-55°C	+25°C	+85°C		F2	F3	F4			1kHz	10kHz	100kHz	1MHz		
0.00	30.66	3801.0	3780.1	3770.0	5.89	5.18	3.77	34.44	-26.6	-28.7	-39.3	0.15	3.44	-78.58	-103.7	-124.6	-144.8	1.0	-76.41
1.00	25.97	3828.9	3809.1	3799.5	5.90	5.10	3.76	34.45	-26.7	-30.4	-37.5	0.10	3.45	-77.74	-103.1	-124.4	-144.5	2.0	-85.18
1.50	25.67	3841.7	3822.1	3812.5	5.91	5.09	3.77	34.45	-26.4	-32.1	-39.9	0.11	2.27	-77.26	-103.2	-124.3	-144.7	3.5	-91.26
2.00	25.75	3854.4	3834.9	3825.3	5.93	5.08	3.79	34.46	-26.4	-30.8	-38.9	0.12	3.27	-78.89	-102.8	-124.0	-144.1	6.0	-96.60
2.50	26.24	3867.4	3847.8	3838.2	5.94	5.11	3.77	34.45	-26.2	-31.5	-39.9	0.13	4.50	-78.29	-102.8	-124.1	-144.1	8.5	-100.52
3.00	27.31	3881.0	3860.9	3851.2	5.87	5.14	3.78	34.44	-25.9	-32.4	-39.0	0.14	3.98	-76.71	-102.6	-123.7	-143.9	10.0	-101.90
3.50	28.70	3895.2	3874.5	3864.6	5.79	5.13	3.75	34.42	-26.4	-32.8	-38.5	0.14	4.01	-77.05	-102.3	-123.5	-143.5	20.8	-108.97
4.00	29.42	3909.4	3888.9	3878.6	5.74	5.03	3.67	34.41	-26.0	-33.4	-40.0	0.16	4.23	-76.88	-102.2	-123.2	-143.5	35.5	-114.22
4.50	29.23	3923.5	3903.6	3893.3	5.82	4.93	3.52	34.42	-25.8	-33.4	-38.8	0.19	3.96	-75.96	-102.0	-123.1	-143.1	60.7	-118.76
5.00	29.24	3937.9	3918.2	3908.1	5.91	4.92	3.45	34.42	-26.6	-33.7	-38.8	0.22	3.62	-76.25	-101.8	-123.0	-142.9	86.7	-122.18
5.50	30.05	3952.9	3932.8	3922.8	5.92	5.01	3.48	34.41	-26.3	-34.6	-39.3	0.23	4.43	-76.47	-101.9	-123.0	-143.4	100.0	-122.93
6.00	30.99	3968.3	3947.9	3937.5	5.91	5.04	3.54	34.39	-26.3	-33.5	-38.7	0.23	5.27	-75.71	-101.2	-122.6	-142.9	148.1	-126.58
6.50	31.26	3983.9	3963.4	3952.8	5.89	5.03	3.50	34.38	-26.8	-32.3	-39.3	0.23	4.09	-76.04	-101.5	-122.4	-142.6	177.0	-127.92
7.00	31.33	3999.5	3979.0	3968.4	5.88	5.01	3.42	34.38	-26.6	-34.6	-40.0	0.25	3.10	-75.31	-101.3	-122.4	-142.8	211.6	-129.89
7.50	31.45	4015.3	3994.7	3984.0	5.86	4.99	3.37	34.37	-26.9	-33.9	-40.8	0.27	4.34	-76.47	-100.8	-122.0	-142.2	302.4	-132.78
8.00	31.10	4030.8	4010.4	3999.6	5.85	4.92	3.33	34.37	-26.8	-31.6	-41.8	0.29	4.89	-74.92	-100.7	-122.0	-142.4	361.5	-134.62
8.50	30.12	4046.0	4025.9	4015.1	5.90	4.89	3.25	34.37	-26.8	-33.7	-43.1	0.32	5.13	-75.46	-100.6	-121.8	-142.0	507.5	-137.16
9.00	29.24	4061.2	4041.0	4030.2	5.91	4.88	3.23	34.36	-26.8	-31.0	-44.5	0.34	4.70	-75.19	-100.4	-122.0	-142.3	606.7	-138.19
9.50	28.60	4076.2	4055.6	4044.8	5.89	4.92	3.24	34.35	-26.3	-31.4	-47.0	0.34	3.34	-75.00	-100.2	-121.6	-141.7	851.6	-142.09
10.00	27.62	4090.7	4069.9	4058.9	5.88	4.93	3.23	34.35	-27.4	-31.1	-50.3	0.34	3.95	-75.00	-100.4	-121.3	-141.7	1000.0	-143.15

*at 25°C unless mentioned otherwise

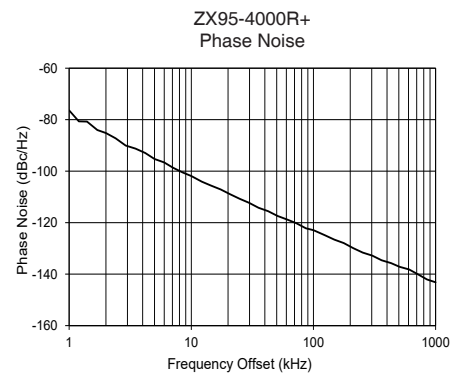
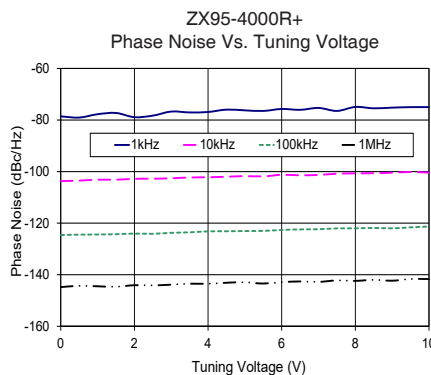
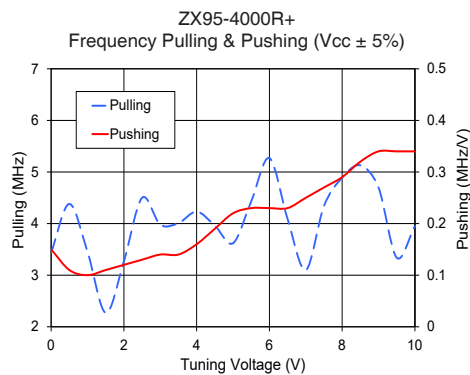
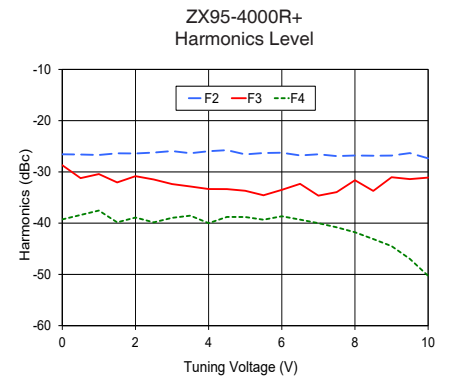
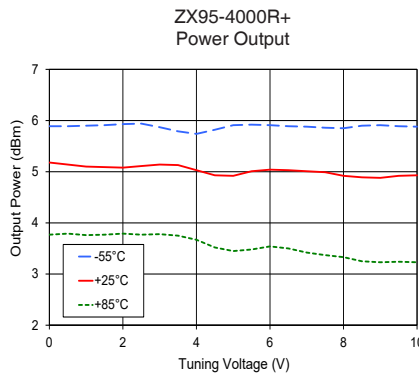
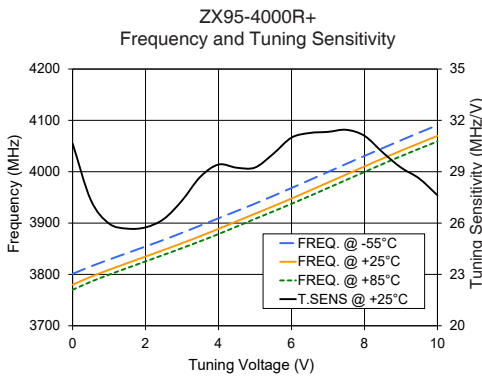

Additional Notes

- Performance and quality attributes and conditions not expressly stated in this specification document are intended to be excluded and do not form a part of this specification document.
- Electrical specifications and performance data contained in this specification document are based on Mini-Circuit's applicable established test performance criteria and measurement instructions.
- The parts covered by this specification document are subject to Mini-Circuits standard limited warranty and terms and conditions (collectively, "Standard Terms"); Purchasers of this part are entitled to the rights and benefits contained therein. For a full statement of the Standard Terms and the exclusive rights and remedies thereunder, please visit Mini-Circuits' website at www.minicircuits.com/MCLStore/terms.jsp

