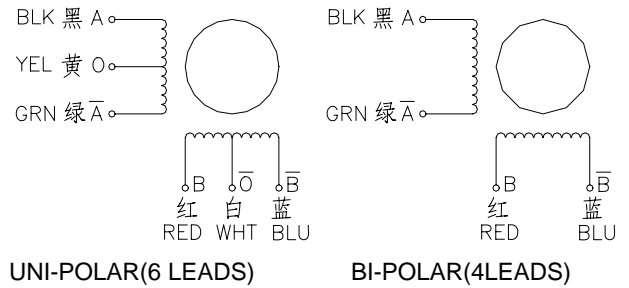
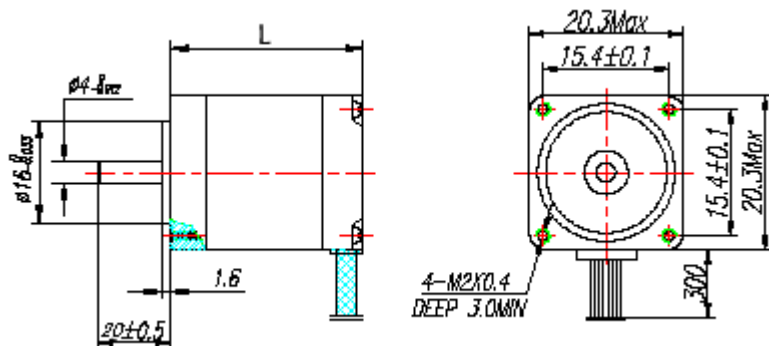

# 2 Phase Hybrid Stepper Motor 8HY series-Size 20mm(1.8 degree)

**Wiring Diagram:**

**Electrical Specifications:**

Model	Phase Voltage (V)	Phase Current (A)	Phase Resistance (ohm)	Phase Inductance (mH)	Holding Torque (N.cm)	Lead Wires (No.)	Weight (g)	Length (mm)
8HY26-0204A	4.0	0.2	23	8.2	1.6	4	40	26
8HY28-0204A	12.0	0.2	23	8.2	1.6	4	50	28
8HY28-0604A	1.9	0.6	3.2	0.9	1.6	4	50	28
8HY33-0204A	5.0	0.2	25	8.4	2.0	4	70	33
8HY33-0604A	2.7	0.6	4.5	1.2	2.0	4	70	33
8HY40-0204A	6.4	0.2	32	8.8	2.8	4	80	40
8HY40-0604A	3.5	0.6	5.8	1.6	2.8	4	80	40

\*Note: We can manufacture products according to customer's requirements.

**Dimensions: unit=mm**

**Motor Length:**

Model	Length
8HY23XX	28 mm
8HY33XX	33 mm

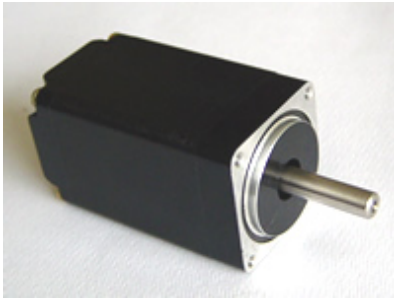
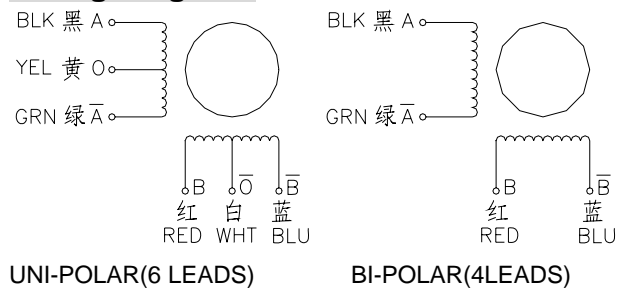
# 2 Phase Hybrid Stepper Motor 11HY series-Size 28mm(1.8 degree)

**Wiring Diagram:**

**Electrical Specifications:**

Series Model	Step Angle (deg)	Motor Length (mm)	Rated Current (A)	Phase Resistance (ohm)	Phase Inductance (mH)	Holding Torque (N.cm Min)	Detent Torque (N.cm Max)	Rotor Inertia (g.cm <sup>2</sup> )	Lead Wire (No.)	Motor Weight (g)
11HY2401	1.8	28	0.6	4.2	2.2	4.5	0.3	6	4	105
11HY2402	1.8	28	0.35	12	5.8	4.5	0.3	6	4	105
11HY3401	1.8	33	0.6	5.5	3.2	6.0	0.4	8	4	110
11HY3402	1.8	33	0.35	15	9.2	6.0	0.4	8	4	110
11HY4401	1.8	41	0.6	7.0	6.0	6.0	0.5	11	4	140
11HY4402	1.8	41	0.35	20	15	6.0	0.5	11	4	140
11HY5401	1.8	50	0.6	9.0	7.2	10	0.8	13	4	180
11HY5402	1.8	50	0.35	24	18.5	10	0.8	13	4	180

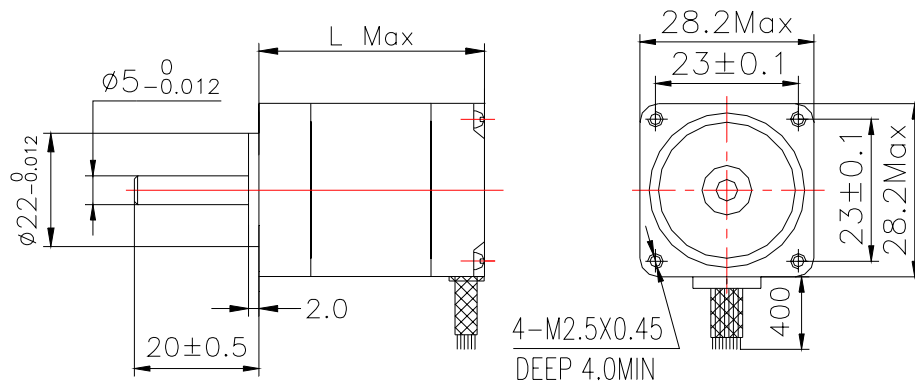
\*Note: We can manufacture products according to customer's requirements.

**Dimensions: unit=mm**

**Motor Length:**

Model	Length
11HY2XXX	28 mm
11HY3XXX	33 mm
11HY4XXX	41 mm
11HY5XXX	50 mm

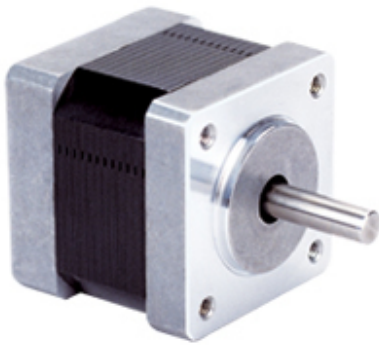
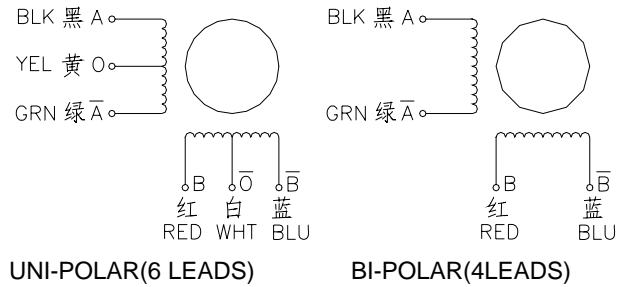
# 2 Phase Hybrid Stepper Motor 14HM series-Size 35mm(0.9 degree)

**Wiring Diagram:**

**Electrical Specifications:**

Series Model	Step Angle (deg)	Motor Length (mm)	Rated Current (A)	Phase Resistance (ohm)	Phase Inductance (mH)	Holding Torque (N.cm Min)	Detent Torque (N.cm Max)	Rotor Inertia (g.cm <sup>2</sup> )	Lead Wire (No.)	Motor Weight (g)
14HM2401	0.9	27	0.8	4.5	4.2	9	0.3	12	4	130
14HM2402	0.9	27	0.55	10	9.5	9	0.3	12	4	130
14HM2403	0.9	27	0.36	22	20	9	0.3	12	4	130
14HM2630	0.9	27	0.4	30	12	8	0.3	12	6	130
14HM3401	0.9	34	0.8	6	10	14	0.6	18	4	190
14HM3402	0.9	34	0.55	12	19	14	0.6	18	4	190
14HM3403	0.9	34	0.36	28	42	14	0.6	18	4	190
14HM3630	0.9	34	0.4	30	18	10	0.6	18	6	190

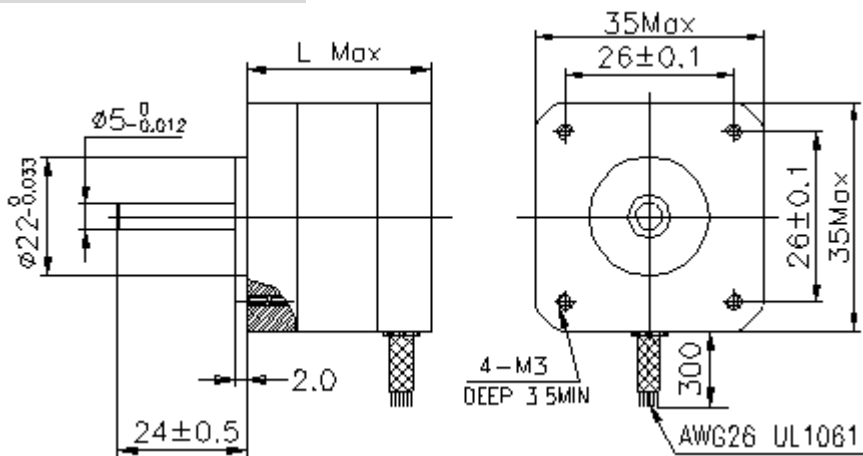
\*Note: We can manufacture products according to customer's requirements.

**Dimensions: unit=mm**

**Motor Length:**

Model	Length
14HM2XXX	27 mm
14HM3XXX	34 mm

# 2 Phase Hybrid Stepper Motor 14HR series-Size 36mm(0.9 degree)

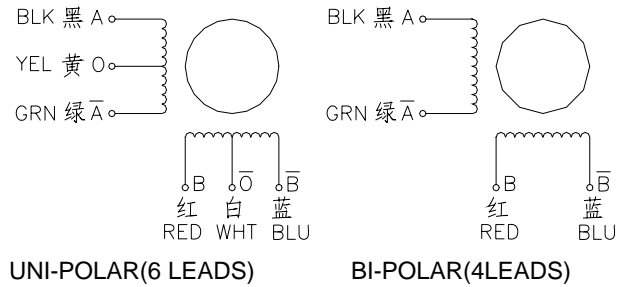

**Wiring Diagram:**



**Electrical Specifications:**

Series Model	Step Angle (deg)	Motor Length (mm)	Rated Current (A)	Phase Resistance (ohm)	Phase Inductance (mH)	Holding Torque (N.cm Min)	Detent Torque (N.cm Max)	Rotor Inertia (g.cm <sup>2</sup> )	Lead Wire (No.)	Motor Weight (g)
14HR1403	0.9	15.2	0.3	16.8	8.5	3.6	0.3	7.3	4	60
14HR2445	0.9	19.7	0.45	15	8.2	8.8	0.3	19	4	110

\*Note: We can manufacture products according to customer's requirements.

**Dimensions: unit=mm**

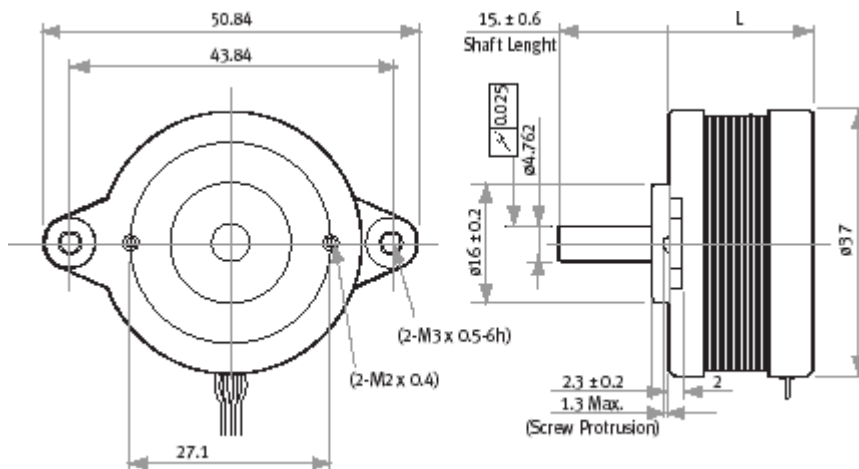

**Motor Length:**

Model	Length
14HR1XXX	15.2 mm
14HR2XXX	19.7 mm

# 2 Phase Hybrid Stepper Motor 14HY series-Size 35mm(1.8 degree)

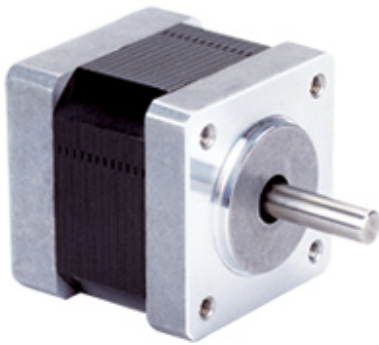

**Wiring Diagram:**

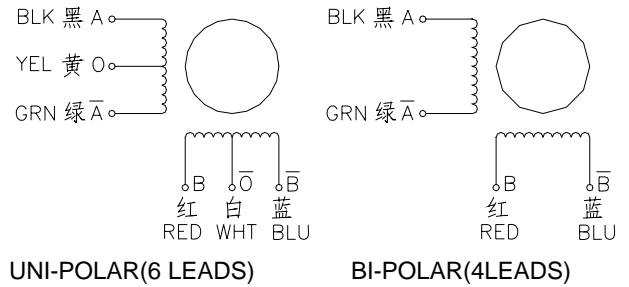

**Electrical Specifications:**

Series Model	Step Angle (deg)	Motor Length (mm)	Rated Current (A)	Phase Resistance (ohm)	Phase Inductance (mH)	Holding Torque (N.cm Min)	Detent Torque (N.cm Max)	Rotor Inertia (g.cm <sup>2</sup> )	Lead Wire (No.)	Motor Weight (g)
14HY0401	1.8	20	0.38	20	16	6	0.5	11	4	80
14HY2420	1.8	28	0.46	20	14	12	0.8	11	4	120
14HY2402	1.8	28	0.8	5.0	5.0	12	0.8	11	4	120
14HY2630	1.8	28	0.4	30	11	9	0.8	11	6	120
14HY3401	1.8	34	0.42	25	32	18	1.0	13	4	160
14HY3402	1.8	34	0.8	6.5	9.8	18	1.0	13	4	160
14HY3630	1.8	34	0.4	30	22	12	1.0	13	6	160

\*Note: We can manufacture products according to customer's requirements.

**Dimensions: unit=mm**

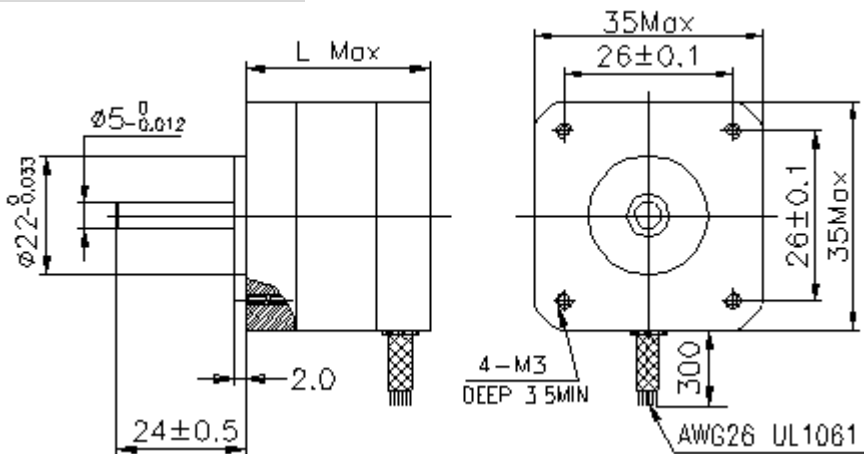

**Motor Length:**

Model	Length
14HY0XXX	20 mm
14HY2XXX	28 mm
14HY3XXX	34 mm

# 2 Phase Hybrid Stepper Motor 16HM series-Size 39mm(0.9 degree)

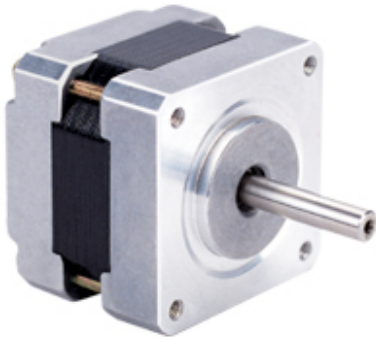
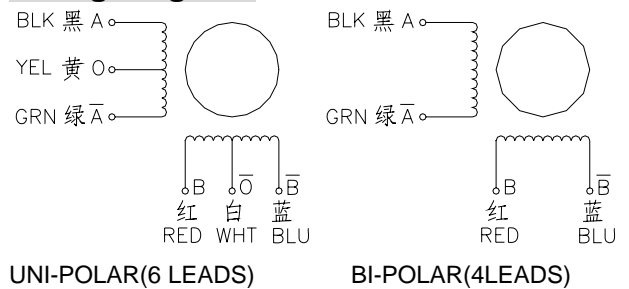
**Wiring Diagram:**

**Electrical Specifications:**

Series Model	Step Angle (deg)	Motor Length (mm)	Rated Current (A)	Phase Resistance (ohm)	Phase Inductance (mH)	Holding Torque (N.cm Min)	Detent Torque (N.cm Max)	Rotor Inertia (g.cm <sup>2</sup> )	Lead Wire (No.)	Motor Weight (g)
16HM0401	0.9	20	0.42	20	16	8	0.5	15	4	100
16HM2410	0.9	26	0.6	9	16	14	0.8	18	4	120
16HM3401	0.9	34	0.6	9	15	16	1.1	23	4	160
16HM3402	0.9	34	1.2	2.5	3.6	16	1.1	23	4	160
16HM3630	0.9	34	0.4	30	16	12	1.1	23	6	160
16HM4401	0.9	40	0.6	12	20	22	1.4	30	4	210
16HM4402	0.9	40	1.2	3.2	5.5	22	1.4	30	4	210
16HM4630	0.9	40	0.4	30	26	18	1.4	30	6	210

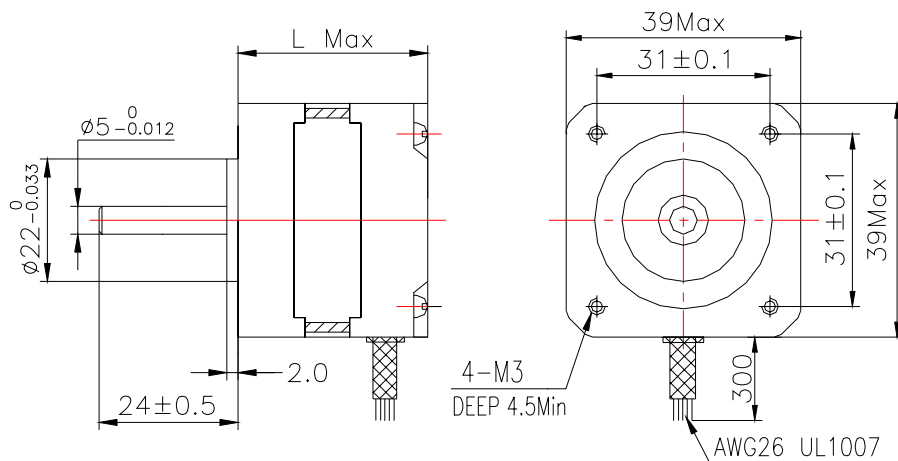
\*Note: We can manufacture products according to customer's requirements.

**Dimensions: unit=mm**

**Motor Length:**

Model	Length
16HM0XXX	20 mm
16HM2XXX	26 mm
16HM3XXX	34 mm
16HM4XXX	40 mm

MotionKing (China) Motor Industry Co., Ltd.

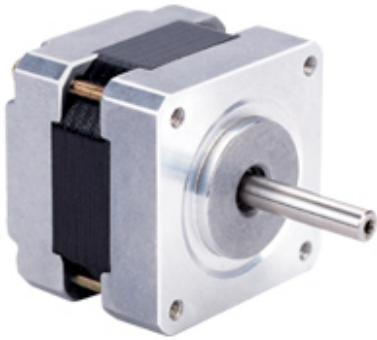
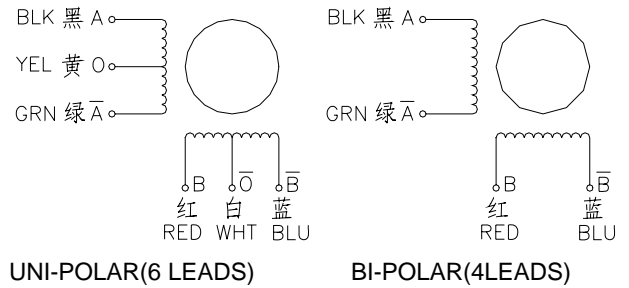
# 2 Phase Hybrid Stepper Motor 16HY series-Size 39mm(1.8 degree)

**Wiring Diagram:**

**Electrical Specifications:**

Series Model	Step Angle (deg)	Motor Length (mm)	Rated Current (A)	Phase Resistance (ohm)	Phase Inductance (mH)	Holding Torque (N.cm Min)	Detent Torque (N.cm Max)	Rotor Inertia (g.cm <sup>2</sup> )	Lead Wire (No.)	Motor Weight (g)
16HY0401	1.8	20	0.42	18	12	8	0.5	12	4	100
16HY2410	1.8	26	0.6	9	10	14	0.8	14	4	120
16HY3401	1.8	34	0.6	12	13	18	1.0	19	4	160
16HY3402	1.8	34	1.2	3.2	3.0	16	1.0	19	4	160
16HY3630	1.8	34	0.4	30	14	12	1.0	19	6	160
16HY4401	1.8	40	0.6	12	20	24	1.2	24	4	210
16HY4402	1.8	40	1.2	3.8	6.5	24	1.2	24	4	210
16HY4630	1.8	40	0.4	30	22	18	1.2	24	4	210

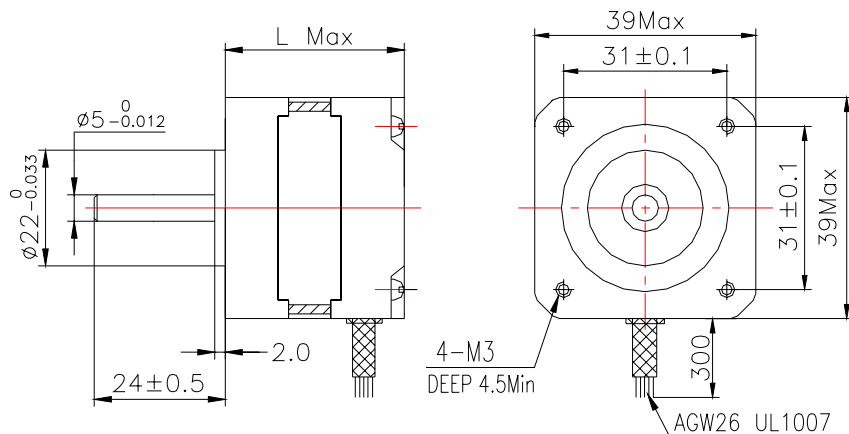
\*Note: We can manufacture products according to customer's requirements.

**Dimensions: unit=mm**

**Motor Length:**

Model	Length
16HY0XXX	20 mm
16HY2XXX	26 mm
16HY3XXX	34 mm
16HY4XXX	40 mm

MotionKing (China) Motor Industry Co., Ltd.

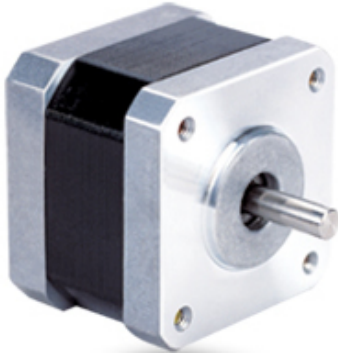
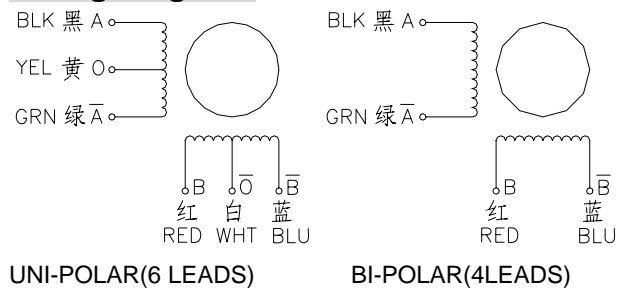
# 2 Phase Hybrid Stepper Motor 17HK series-Size 42mm(0.9 degree)

**Wiring Diagram:**

**Electrical Specifications:**

Series Model	Step Angle (deg)	Motor Length (mm)	Rated Current (A)	Phase Resistance (ohm)	Phase Inductance (mH)	Holding Torque (N.cm Min)	Detent Torque (N.cm Max)	Rotor Inertia (g.cm <sup>2</sup> )	Lead Wire (No.)	Motor Weight (g)
17HK2408	0.9	28	0.6	9	9	10	0.9	20	4	130
17HK3401	0.9	34	1.3	2.4	3.6	24	1.2	34	4	220
17HK3410	0.9	34	1.7	1.2	2.2	24	1.2	34	4	220
17HK3430	0.9	34	0.4	30	45	24	1.2	34	4	220
17HK3630	0.9	34	0.4	30	22	20	1.2	34	6	220
17HK3616	0.9	34	0.16	75	54	12	1.2	34	6	220
17HK4401	0.9	40	1.7	1.5	3.8	36	1.8	54	4	280
17HK4402	0.9	40	1.3	2.5	6.2	36	1.8	54	4	280
17HK4602	0.9	40	1.2	3.2	3.8	26	1.8	54	6	280
17HK4630	0.9	40	0.4	30	34	26	1.8	54	6	280
17HK8401	0.9	48	1.7	1.8	4.0	42	2.2	68	4	350
17HK8402	0.9	48	1.3	3.0	7.0	36	2.2	68	4	350
17HK8403	0.9	48	2.3	1.2	2.0	42	2.2	68	4	350
17HK8630	0.9	48	0.4	30	28	27	2.2	68	6	350

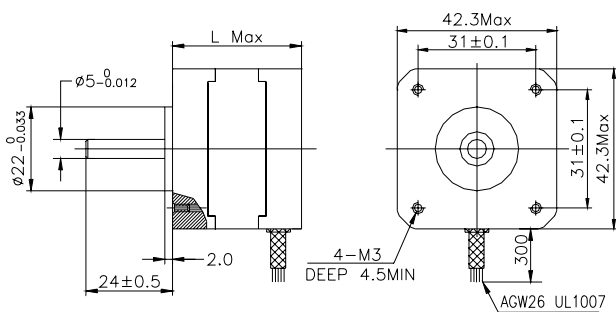
\*Note: We can manufacture products according to customer's requirements.

**Dimensions: unit=mm**

**Motor Length:**

Model	Length
17HK2XXX	28 mm
17HK3XXX	34 mm
17HK4XXX	40 mm
17HK8XXX	48 mm

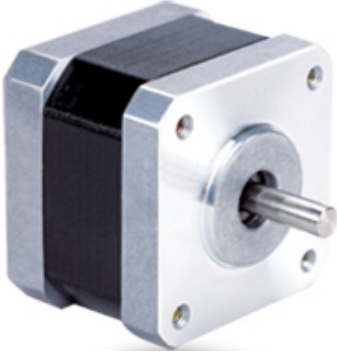

# 2 Phase Hybrid Stepper Motor 17HS series-Size 42mm(1.8 degree)



### Wiring Diagram:

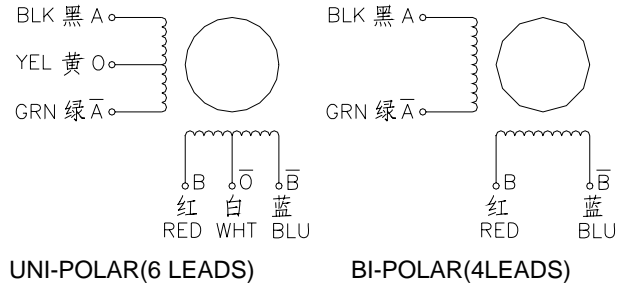

### Electrical Specifications:

Series Model	Step Angle (deg)	Motor Length (mm)	Rated Current (A)	Phase Resistance (ohm)	Phase Inductance (mH)	Holding Torque (N.cm Min)	Detent Torque (N.cm Max)	Rotor Inertia (g.cm <sup>2</sup> )	Lead Wire (No.)	Motor Weight (g)
17HS2408	1.8	28	0.6	8	10	12	1.6	34	4	150
17HS3401	1.8	34	1.3	2.4	2.8	28	1.6	34	4	220
17HS3410	1.8	34	1.7	1.2	1.8	28	1.6	34	4	220
17HS3430	1.8	34	0.4	30	35	28	1.6	34	4	220
17HS3630	1.8	34	0.4	30	18	21	1.6	34	6	220
17HS3616	1.8	34	0.16	75	40	14	1.6	34	6	220
17HS4401	1.8	40	1.7	1.5	2.8	40	2.2	54	4	280
17HS4402	1.8	40	1.3	2.5	5.0	40	2.2	54	4	280
17HS4602	1.8	40	1.2	3.2	2.8	28	2.2	54	6	280
17HS4630	1.8	40	0.4	30	28	28	2.2	54	6	280
17HS8401	1.8	48	1.7	1.8	3.2	52	2.6	68	4	350
17HS8402	1.8	48	1.3	3.2	5.5	52	2.6	68	4	350
17HS8403	1.8	48	2.3	1.2	1.6	46	2.6	68	4	350
17HS8630	1.8	48	0.4	30	38	34	2.6	68	6	350

\*Note: We can manufacture products according to customer's requirements.

### Dimensions: unit=mm

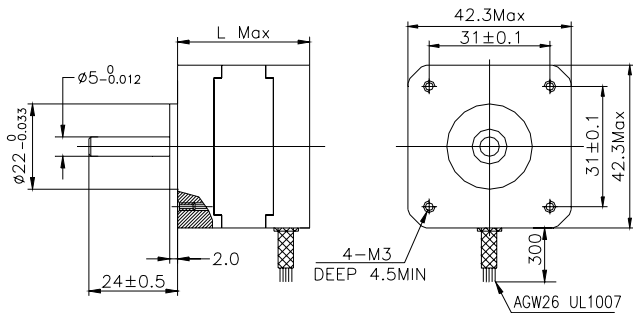

### Motor Length:

Model	Length
17HS2XXX	28 mm
17HS3XXX	34 mm
16HS4XXX	40 mm
16HS8XXX	48 mm

# 2 Phase Hybrid Stepper Motor

## 23HK series-Size 57mm(0.9 degree)

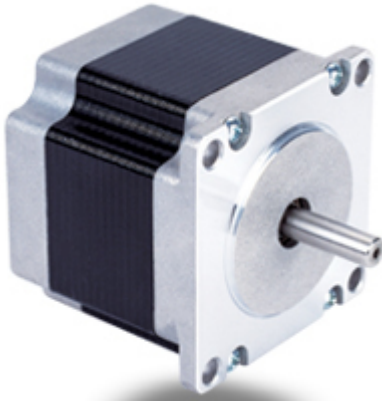
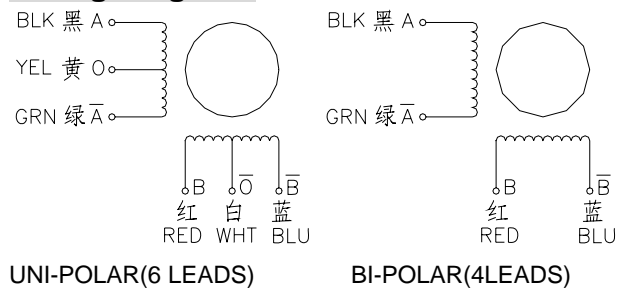

**Wiring Diagram:**

**Electrical Specifications:**

Series Model	Step Angle (deg)	Motor Length (mm)	Rated Current (A)	Phase Resistance (ohm)	Phase Inductance (mH)	Holding Torque (N.cm Min)	Detent Torque (N.cm Max)	Rotor Inertia (g.cm <sup>2</sup> )	Lead Wire (No.)	Motor Weight (g)
23HK0601	0.9	41	1.0	5.2	6.2	24	2.5	150	6	470
23HK0405	0.9	41	0.62	12	28	32	2.5	150	4	470
23HK0408	0.9	41	2.0	1.2	3.0	32	2.5	150	4	470
23HK4425	0.9	45	2.5	1.0	3.0	62	2.8	190	4	520
23HK5406	0.9	51	0.62	13	34	70	3.0	230	4	590
23HK5425	0.9	51	2.5	1.2	3.8	70	3.0	230	4	590
23HK6602	0.9	56	1.5	3.2	6.5	82	3.5	280	6	680
23HK6403	0.9	56	2.5	1.3	5.2	100	3.5	280	4	680
23HK6430	0.9	56	3.0	0.8	2.8	100	3.5	280	4	680
23HK6404	0.9	56	4.2	0.4	1.5	100	3.5	280	4	680
23HK7401	0.9	64	1.0	7.5	28	110	5.0	380	4	850
23HK7425	0.9	64	2.5	1.5	5.8	110	5.0	380	4	850
23HK7430	0.9	64	3.0	0.8	3.0	110	5.0	380	4	850
23HK7404	0.9	64	4.2	0.55	1.5	110	5.0	380	4	850
23HK8603	0.9	76	1.5	4.5	10	125	6.0	440	6	1050
23HK8425	0.9	76	2.5	1.8	8.2	150	6.0	440	4	1050
23HK8430	0.9	76	3.0	1.0	4.3	150	6.0	440	4	1050
23HK8404	0.9	76	4.2	0.65	2.2	150	6.0	440	4	1050

\*Note: We can manufacture products according to customer's requirements.

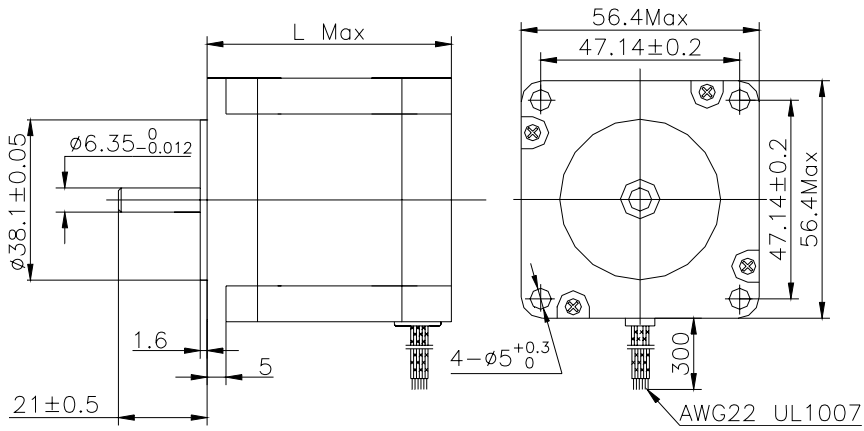
MotionKing (China) Motor Industry Co., Ltd.

**Dimensions: unit=mm**



**Motor Length:**

Model	Length
23HK0XXX	41 mm
23HK4XXX	45 mm
23HK5XXX	51 mm
23HK6XXX	56 mm
23HK7XXX	64 mm
23HK8XXX	76 mm

# 2 Phase Hybrid Stepper Motor 23HS series-Size 57mm(1.8 degree)

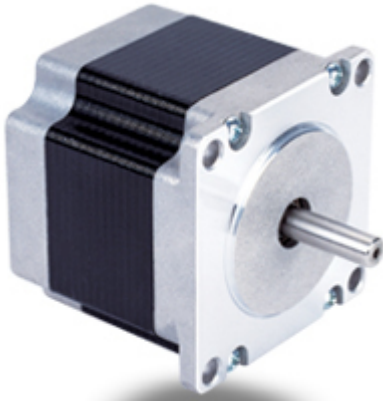
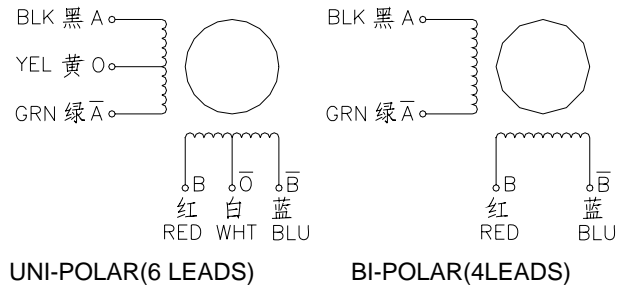

**Wiring Diagram:**

**Electrical Specifications:**

Series Model	Step Angle (deg)	Motor Length (mm)	Rated Current (A)	Phase Resistance (ohm)	Phase Inductance (mH)	Holding Torque (N.cm Min)	Detent Torque (N.cm Max)	Rotor Inertia (g.cm <sup>2</sup> )	Lead Wire (No.)	Motor Weight (g)
23HS0601	1.8	41	1.0	5.2	5.5	40	2.5	150	6	470
23HS0405	1.8	41	0.62	12	24	55	2.5	150	4	470
23HS0408	1.8	41	2.0	1.2	2.5	55	2.5	150	4	470
23HS4412	1.8	45	0.62	12	26	80	2.8	190	4	520
23HS4425	1.8	45	2.5	1.0	2.2	80	2.8	190	4	520
23HS5406	1.8	51	0.62	13	28	90	2.8	190	4	520
23HS5425	1.8	51	2.5	1.2	3.2	90	2.8	190	4	520
23HS5602	1.8	51	0.8	6.8	9.2	63	3.0	230	6	590
23HS6602	1.8	56	1.5	3.2	5.5	90	3.5	280	6	590
23HS6403	1.8	56	2.5	1.3	3.6	110	3.5	280	4	680
23HS6430	1.8	56	3.0	0.8	2.4	110	3.5	280	4	680
23HS6404	1.8	56	4.2	0.4	1.2	110	3.5	280	4	680
23HS7401	1.8	64	1.0	7.5	20	150	5.0	380	4	850
23HS7425	1.8	64	2.5	1.5	4.5	150	5.0	380	4	850
23HS7430	1.8	64	3.0	0.8	2.3	150	5.0	380	4	850
23HS7404	1.8	64	4.2	0.55	1.2	150	5.0	380	4	850
23HS8603	1.8	76	1.5	4.5	10	140	6.0	440	6	1050
23HS8425	1.8	76	2.5	1.8	6.5	180	6.0	440	4	1050
23HS8430	1.8	76	3.0	1.0	3.5	180	6.0	440	4	1050
23HS8404	1.8	76	4.2	0.6	1.8	180	6.0	440	4	1050
23HS1430	1.8	100	3.0	1.4	5.5	250	10	680	4	1250
23HS1410	1.8	100	4.2	0.8	3.0	250	10	680	4	1250
23HS2430	1.8	112	3.0	1.6	6.8	280	12	800	4	1400
23HS2410	1.8	112	4.2	0.9	3.8	280	12	800	4	1400

\*Note: We can manufacture products according to customer's requirements.

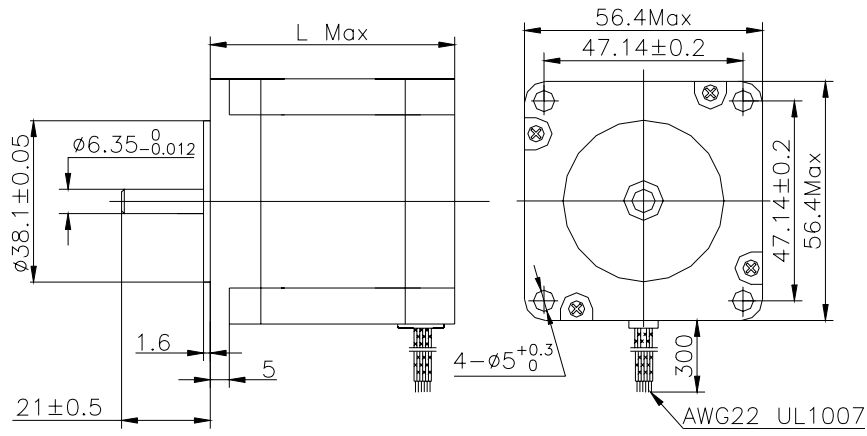
MotionKing (China) Motor Industry Co., Ltd.

**Dimensions: unit=mm**



**Motor Length:**

Model	Length
23HS0XXX	41 mm
23HS4XXX	45 mm
23HS5XXX	51 mm
23HS6XXX	56 mm
23HS7XXX	64 mm
23HS8XXX	76 mm
23HS1XXX	100 mm
23HS2XXX	112 mm

# 2 Phase Hybrid Stepper Motor 23HY series-Size 57mm(1.8 degree)

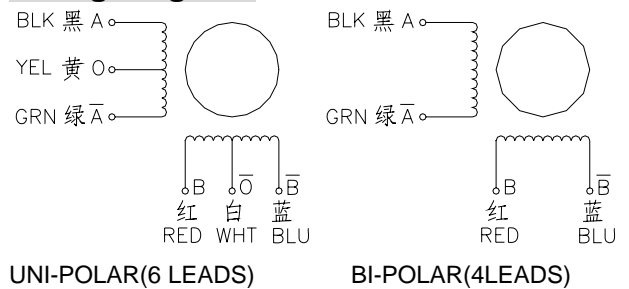

**Wiring Diagram:**

**Electrical Specifications:**

Series Model	Step Angle (deg)	Motor Length (mm)	Rated Current (A)	Phase Resistance (ohm)	Phase Inductance (mH)	Holding Torque (N.cm Min)	Detent Torque (N.cm Max)	Rotor Inertia (g.cm <sup>2</sup> )	Lead Wire (No.)	Motor Weight (g)
23HY4607	1.8	41	0.38	32	30	30	3.5	60	6	450
23HY4455	1.8	41	1.55	1.8	3.5	22	3.5	60	4	450
23HY4456	1.8	41	2.1	0.8	1.4	32	3.5	60	4	450
23HY4656	1.8	41	1.5	1.5	1.4	24	3.5	60	6	450
23HY5607	1.8	51	0.38	32	28	38	5.5	118	6	600
23HY5666	1.8	51	0.85	7.1	8.5	45	5.5	118	6	600
23HY5627	1.8	51	1.4	2.5	32	45	5.5	118	6	600
23HY5481	1.8	51	1.4	2.5	6.2	62	5.5	118	6	600
23HY5460	1.8	51	2.0	1.3	3.2	62	5.5	118	4	600
23HY6684	1.8	56	0.6	20	20	60	6.5	145	6	650
23HY6669	1.8	56	1.2	5.0	6.8	60	6.5	145	6	650
23HY6659	1.8	56	1.6	5.2	30	60	6.5	145	6	650
23HY6609	1.8	56	2.4	1.0	1.2	60	6.5	145	6	650
23HY6496	1.8	56	2.5	1.2	3.0	80	6.5	145	4	650
23HY7406	1.8	76	4.2	0.6	1.4	110	6.5	145	4	800
23HY7407	1.8	76	2.1	2.2	6.2	110	9.5	230	6	800
23HY7408	1.8	76	3.6	0.8	2.2	110	9.5	230	4	800

\*Note: We can manufacture products according to customer's requirements.

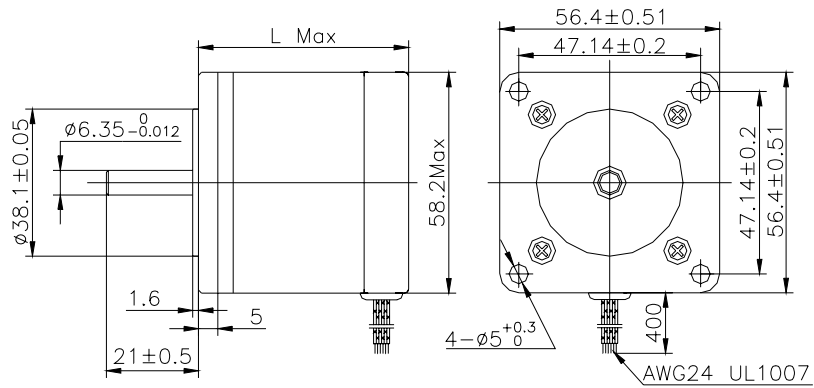
MotionKing (China) Motor Industry Co., Ltd.

**Dimensions: unit=mm**



**Motor Length:**

Model	Length
23HY4XXX	41 mm
23HY5XXX	51 mm
23HY6XXX	56 mm
23HY7XXX	76 mm

# 2 Phase Hybrid Stepper Motor 24HS series-Size 60mm(1.8 degree)



**Wiring Diagram:**

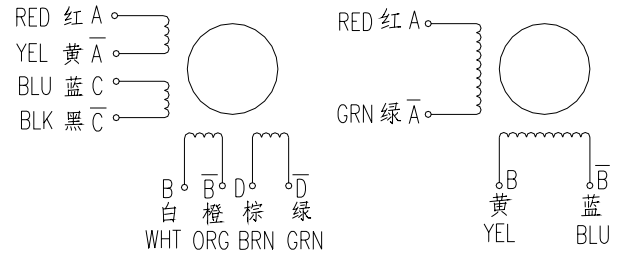

UNI/BI-POLAR(8 LEADS)

BI-POLAR(4LEADS)

**Electrical Specifications:**

Series Model	Step Angle (deg)	Motor Length (mm)	Rated Current (A)	Phase Resistance (ohm)	Phase Inductance (mH)	Holding Torque (N.cm Min)	Detent Torque (N.cm Max)	Rotor Inertia (g.cm <sup>2</sup> )	Lead Wire (No.)	Motor Weight (g)	
24HS4428	1.8	45	2.8	0.6	1.3	90	2.8	190	4	570	
24HS7428	1.8	76	2.8	1.4	3.8	220	8	380	4	1000	
24HS1442	1.8	90	4.2	0.7	3.2	300	10	680	4	1300	
24HS1428	1.8	90	2.8	1.4	5.6	300	10	680	4	1300	
24HS1830	U	1.8	90	3.0	1.4	3.2	212	10	680	8	1300
	B(s)			2.1	2.8	12.8	300				
	B(p)			4.2	0.7	3.2	300				

\*Note: We can manufacture products according to customer's requirements.

**Dimensions: unit=mm**

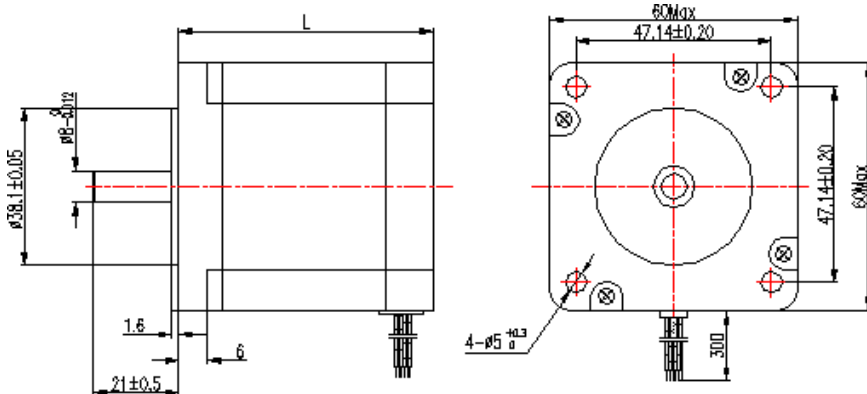

**Motor Length:**

Model	Length
24HS4XXX	45 mm
24HS 5XXX	56 mm
24HS 6XXX	64 mm
24HS 7XXX	76 mm
24HS 1XXX	90 mm



# 2 Phase Hybrid Stepper Motor 34HS series-Size 86mm(1.8 degree)

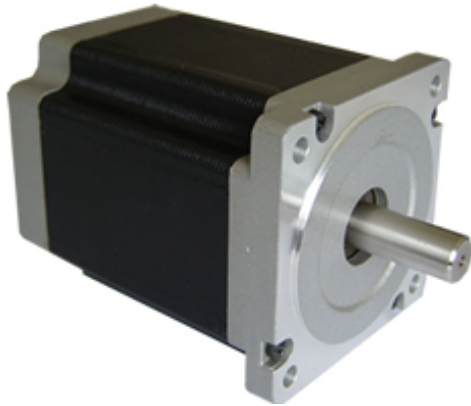

### Wiring Diagram:

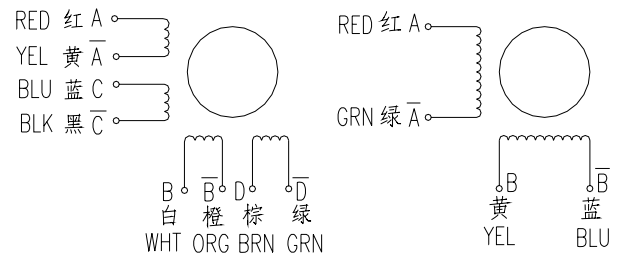

UNI/BI-POLAR(8 LEADS)

BI-POLAR(4LEADS)

### Electrical Specifications (UNI-POLAR):

Series Model	Step Angle (deg)	Motor Length (mm)	Rated Current (A)	Phase Resistance (ohm)	Phase Inductance (mH)	Holding Torque (N.cm Min)	Detent Torque (N.cm Max)	Rotor Inertia (g.cm <sup>2</sup> )	Lead Wire (No.)	Motor Weight (kg)
34HS6801	1.8	63	4.0	0.6	1.6	220	5.5	0.85	8	2.0
34HS6802	1.8	63	5.0	0.4	1.0	220	5.5	0.85	8	2.0
34HS6803	1.8	63	2.7	1.2	3.5	220	5.5	0.85	8	2.0
34HS8801	1.8	78	4.0	0.7	3.0	300	6.5	1.05	8	2.5
34HS8802	1.8	78	5.0	0.5	1.8	300	6.5	1.05	8	2.5
34HS8803	1.8	78	2.7	1.6	5.6	300	6.5	1.05	8	2.5
34HS9801	1.8	98	4.0	0.98	4.1	490	9.5	1.55	8	3.0
34HS9802	1.8	98	5.0	0.65	2.4	490	9.5	1.55	8	3.0
34HS9803	1.8	98	2.7	1.9	8.6	490	9.5	1.55	8	3.0
34HS4801	1.8	114	4.0	1.1	5.5	580	12.5	1.8	8	4.0
34HS4802	1.8	114	5.0	0.75	3.2	580	12.5	1.8	8	4.0
34HS4803	1.8	114	2.7	2.0	11.5	580	12.5	1.8	8	4.0
34HS2801	1.8	126	4.0	1.3	5.8	640	18.5	2.2	8	4.5
34HS2802	1.8	126	5.0	0.85	3.4	640	18.5	2.2	8	4.5
34HS2803	1.8	126	2.7	2.5	12.5	640	18.5	2.2	8	4.5
34HS5801	1.8	150	4.0	1.4	9.2	850	24.5	2.5	8	5.0
34HS5802	1.8	150	5.0	0.9	5.2	850	24.5	2.5	8	5.0
34HS5803	1.8	150	2.7	2.9	17.5	850	24.5	2.5	8	5.0
34HS5804	1.8	150	4.7	0.75	8.4	930	28	3.7	4	5.0

**\*Note:**

- 1) We can manufacture products according to customer's requirements.
- 2) We can also supply BI-POLAR stepper motors, but they were not listed, the details please contact us.

**Dimensions: unit=mm**

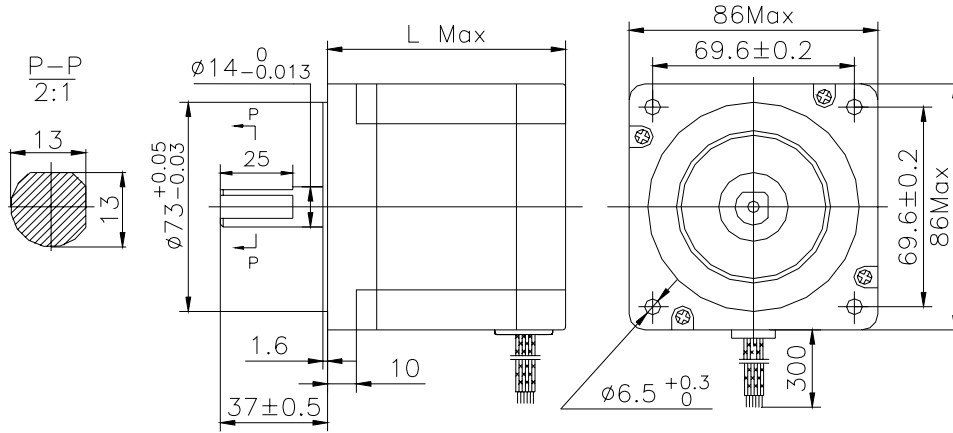

**Motor Length:**

Model	Length
34HS6XXX	66 mm
34HS8XXX	78 mm
34HS9XXX	98 mm
34HS4XXX	114 mm
34HS2XXX	126 mm
34HS5XXX	150 mm

# 2 Phase Hybrid Stepper Motor 34HM series-Size 86mm(0.9 degree)

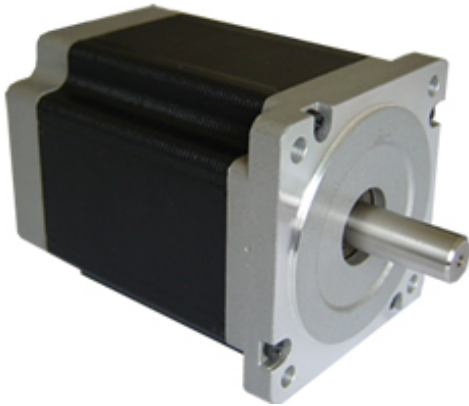

### Wiring Diagram:

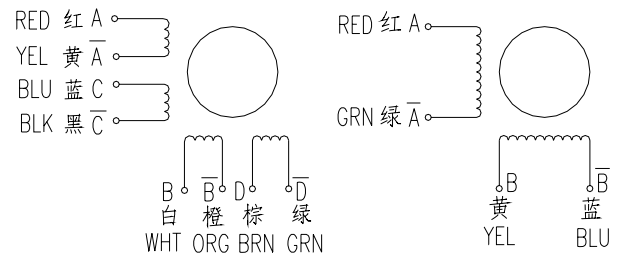

UNI/BI-POLAR(8 LEADS)

BI-POLAR(4LEADS)

### Electrical Specifications (UNI-POLAR):

Series Model	Step Angle (deg)	Motor Length (mm)	Rated Current (A)	Phase Resistance (ohm)	Phase Inductance (mH)	Holding Torque (N.cm Min)	Detent Torque (N.cm Max)	Rotor Inertia (g.cm <sup>2</sup> )	Lead Wire (No.)	Motor Weight (kg)
34HM6801	0.9	66	4.0	0.6	1.6	200	5.0	0.85	8	2.0
34HM6802	0.9	66	5.0	0.4	1.0	200	5.0	0.85	8	2.0
34HM6803	0.9	66	2.7	1.2	3.5	200	5.0	0.85	8	2.0
34HM8801	0.9	78	4.0	0.7	3.0	270	5.5	1.05	8	2.5
34HM8802	0.9	78	5.0	0.5	0.9	270	5.5	1.05	8	2.5
34HM8803	0.9	78	2.7	1.6	5.6	270	5.5	1.05	8	2.5
34HM9801	0.9	98	4.0	0.98	4.1	450	8.0	1.55	8	3.0
34HM9802	0.9	98	5.0	0.65	2.4	450	8.0	1.55	8	3.0
34HM9803	0.9	98	2.7	1.9	8.6	450	8.0	1.55	8	3.0
34HM4801	0.9	114	4.0	1.1	5.5	520	10.0	1.80	8	4.0
34HM4802	0.9	114	5.0	0.75	3.2	520	10.0	1.80	8	4.0
34HM4803	0.9	114	2.7	2.0	11.5	520	10.0	1.80	8	4.0
34HM2801	0.9	126	4.0	1.3	5.8	580	15.5	2.20	8	4.5
34HM2802	0.9	126	5.0	0.85	3.4	580	15.5	2.20	8	4.5
34HM2803	0.9	126	2.7	2.5	12.5	580	15.5	2.20	8	4.5
34HM5801	0.9	150	4.0	1.4	9.2	780	19.0	2.50	8	5.0
34HM5802	0.9	150	5.0	0.9	5.2	780	19.0	2.50	8	5.0
34HM5803	0.9	150	2.7	2.9	17.5	780	19.0	2.50	8	5.0

**\*Note:**

- 1) We can manufacture products according to customer's requirements.
- 2) We can also supply BI-POLAR stepper motors, but they were not listed, the details please contact us.

MotionKing (China) Motor Industry Co., Ltd.

**Dimensions: unit=mm**

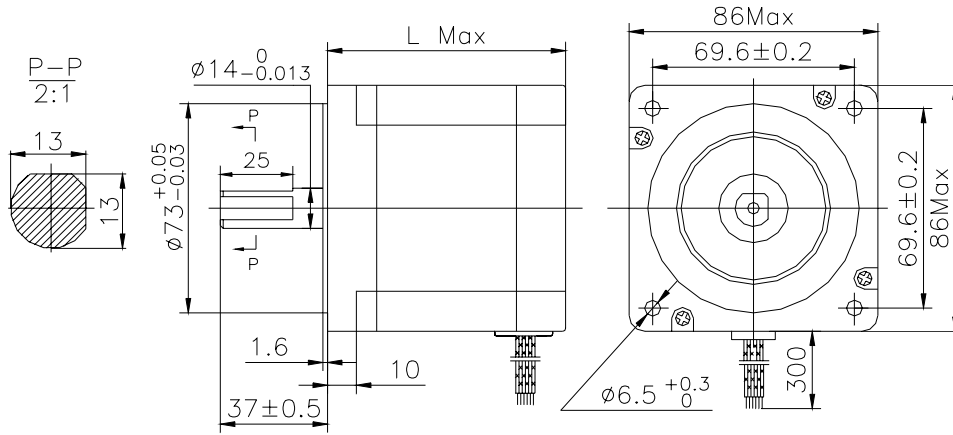

**Motor Length:**

Model	Length
34HM6XXX	66 mm
34HM8XXX	78 mm
34HM9XXX	98 mm
34HM4XXX	114 mm
34HM2XXX	126 mm
34HM5XXX	150 mm

# 2 Phase Hybrid Stepper Motor 34HY series-Size 86mm(1.8 degree)



### Wiring Diagram:

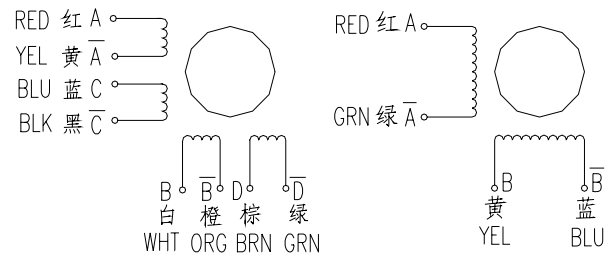

UNI/BI-POLAR(8 LEADS)

BI-POLAR(4LEADS)

### Electrical Specifications (UNI-POLAR):

Series Model	Step Angle (deg)	Motor Length (mm)	Rated Current (A)	Phase Resistance (ohm)	Phase Inductance (mH)	Holding Torque (N.cm Min)	Detent Torque (N.cm Max)	Rotor Inertia (g.cm <sup>2</sup> )	Lead Wire (No.)	Motor Weight (kg)
34HY6801	1.8	63	4.0	0.68	2.0	180	4.5	0.64	8	1.6
34HY6802	1.8	63	5.0	0.45	1.5	180	4.5	0.64	8	1.6
34HY6803	1.8	63	2.7	1.2	4.5	180	4.5	0.64	8	1.6
34HY6804	1.8	63	2.1	1.9	7.2	180	4.5	0.64	8	1.6
34HY9801	1.8	92	4.0	0.89	3.8	320	6.5	1.3	8	2.6
34HY9802	1.8	92	5.0	0.58	2.8	320	6.5	1.3	8	2.6
34HY9803	1.8	92	2.7	1.7	9.0	320	6.5	1.3	8	2.6
34HY9804	1.8	92	2.1	2.7	15	320	6.5	1.3	8	2.6
34HY1801	1.8	122	4	1.1	5.6	450	10.5	1.9	8	3.8
34HY1802	1.8	122	5.0	0.82	3.6	450	10.5	1.9	8	3.8
34HY1803	1.8	122	2.7	2.5	12.5	450	10.5	1.9	8	3.8

#### \*Note:

- 1) We can manufacture products according to customer's requirements.
- 2) We can also supply BI-POLAR stepper motors, but they were not listed, the details please contact us.

### Dimensions: unit=mm

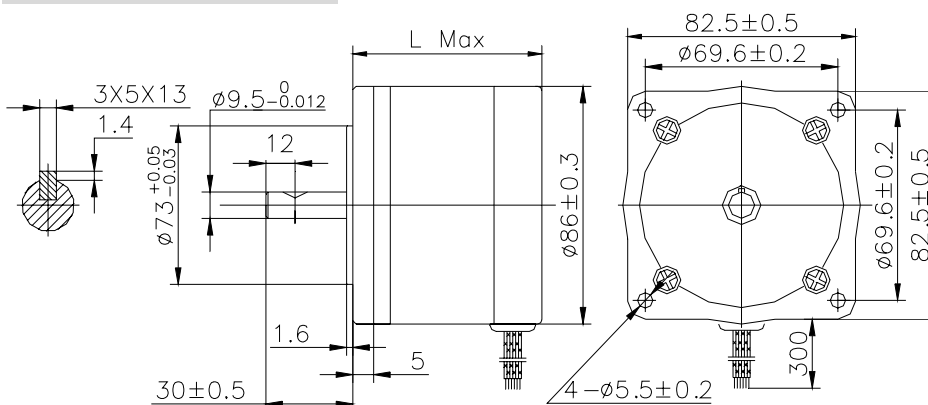

### Moto Length:

Model	Length
34HY6XXX	63 mm
34HY9XXX	92 mm
34HY1XXX	122 mm

# 2 Phase Hybrid Stepper Motor 43HS series-Size 110mm(1.8 degree)

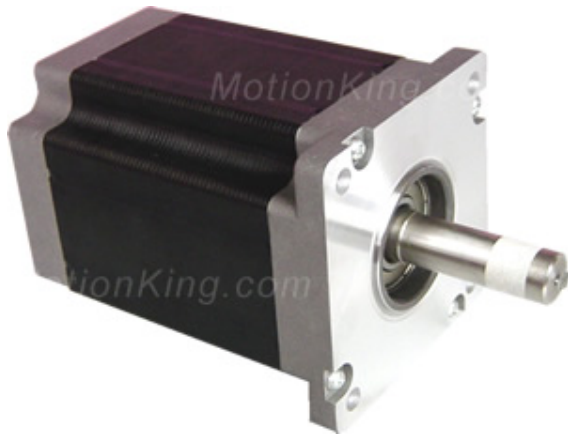

**Wiring Diagram:**

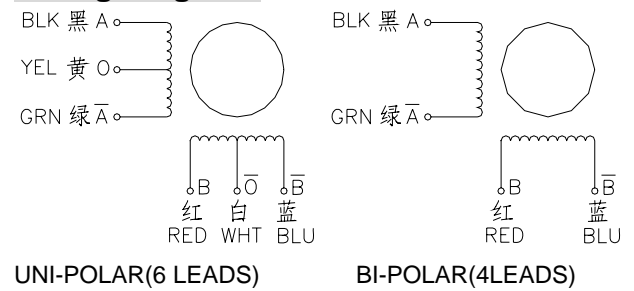

**Electrical Specifications (BI-POLAR):**

Series Model	Step Angle (deg)	Motor Length (mm)	Rated Current (A)	Phase Resistance (ohm)	Phase Inductance (mH)	Holding Torque (N. m Min)	Rotor Inertia (g.cm <sup>2</sup> )	Lead Wire (No.)	Motor Weight (kg)
43HS2A100-604	1.8	100	6.0	0.5	6	12.5	3500	4	5.5
43HS2A115-604	1.8	115	6.0	0.95	15	14.0	5500	4	6.2
43HS2A125-654	1.8	125	6.5	0.66	11	20.0	8500	4	7.5
43HS2A150-654	1.8	150	6.5	1.15	18.9	23.0	11000	4	8.4
43HS2A165-654	1.8	165	6.5	0.65	14	26.0	13000	4	11
43HS2A200-654	1.8	200	6.5	1.00	21	30.0	15000	4	15

**\*Note:**

- 1) We can manufacture products according to customer's requirements.
- 2) We can also supply UNI-POLAR stepper motors, but they were not listed, the details please contact us.

**Dimensions: unit=mm**

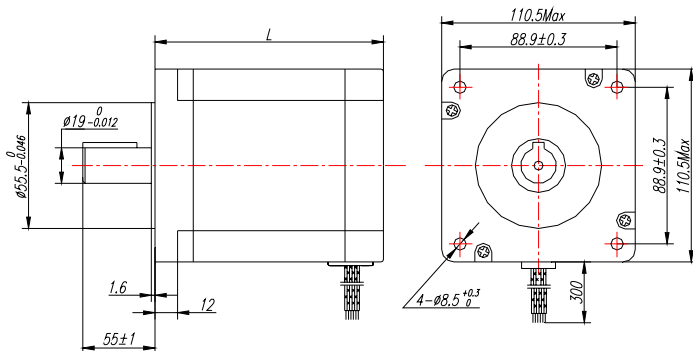

**Motor Length:**

Model	Length
43HS2A115XX	115 mm
43HS2A150XX	150 mm
43HS2A165XX	165 mm