

MABA-008965-CF1160

1:1 Flux Coupled Balun Transformer
5 - 120 MHz

M/A-COM Products
Part Status: Released Rev. V2

Features

- Surface Mount
- 1:1 Impedance
- 75 Ohm
- RoHS Compliant

Description

M/A-COM's MABA-008965-CF1160 is a 1:1 RF flux coupled Transformer in a low cost surface mount package. Ideally suited for high volume CATV application.

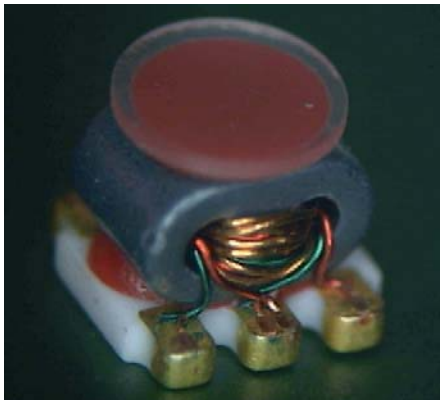

Schematic

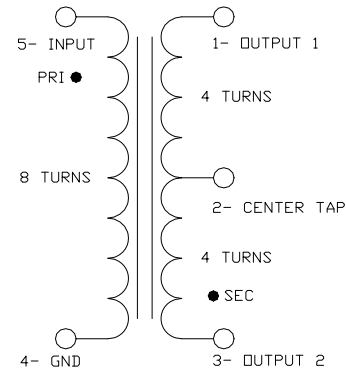

Case Style SM-22A

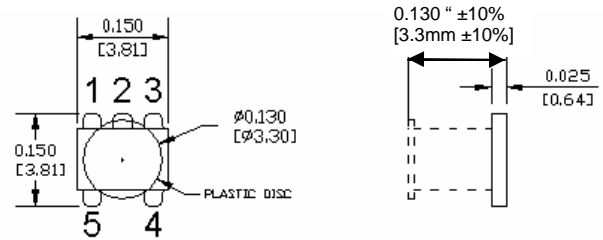

Pin Configuration

Function	Pin Number
Secondary (output)	1
Secondary Centre Tap	2
Secondary Dot (output)	3
Primary (ground)	4
Primary Dot (Input)	5

Ordering Information

Parameter	Absolute Maximum
MABA-008965-CF1160	2000
MABA-008965-CF11TB	Customer Test Board

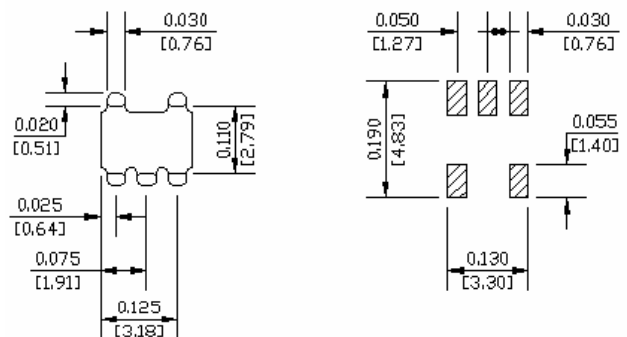

Dimensions are inches [millimeters] ±0.015 [0.38] unless otherwise specified.

Electrical Specifications: $T_A = 25^\circ\text{C}$, 0dBm, $Z_0 = 75\Omega$

Parameter	Test Conditions	Units	Min.	Typ.	Max.
Frequency Range	5 – 120 MHz				
Insertion Loss 1 (Pin 5 to Pin 1)	5 – 80 MHz	dB	–	0.1	0.4
	80 – 120 MHz	dB	–	0.3	0.5
Insertion Loss 2 (Pin 5 to Pin 3)	5 – 80 MHz	dB	–	0.2	0.4
	80 – 120 MHz	dB	–	0.4	0.6
Amplitude Un-Balance	5 – 80 MHz	dB	–	± 0.06	± 0.2
	80 – 120 MHz	dB	–	± 0.18	± 0.3
Phase Un-Balance	5 – 80 MHz	$^\circ$	–	± 0.05	± 1.5
	80 – 120 MHz	$^\circ$	–	± 0.10	± 2.0
Input Return Loss (Pin 5)	5 – 80 MHz	dB	19	25	–
	80 – 120 MHz	dB	15	19	–

Absolute Maximum Ratings

Parameter	Absolute Maximum
RF Power	250mW
DC Current	30mA
Operating Temperature	-40°C to $+85^\circ\text{C}$
Storage Temperature	-40°C to $+85^\circ\text{C}$

Recommended PCB Configuration

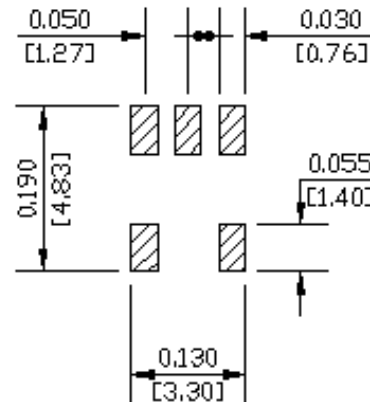

1:1 Flux Coupled Balun Transformer
5 - 120 MHz

M/A-COM Products
Part Status: Released Rev. V2

Typical Performance: $T_A = 25^\circ\text{C}$, 0dBm, $Z_0 = 75\Omega$

Insertion Loss 1 (Pin5 - Pin1)

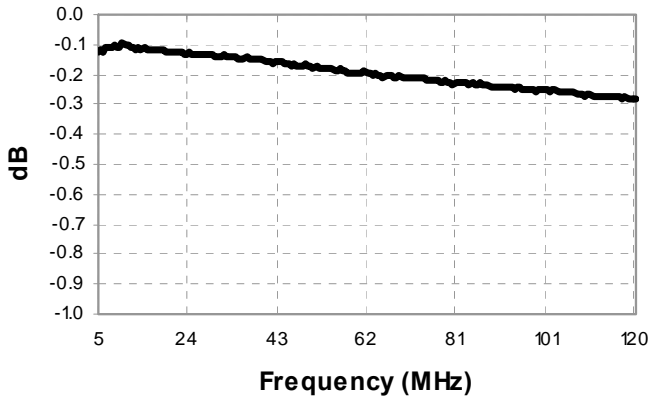

Insertion Loss 2 (Pin5 - Pin3)

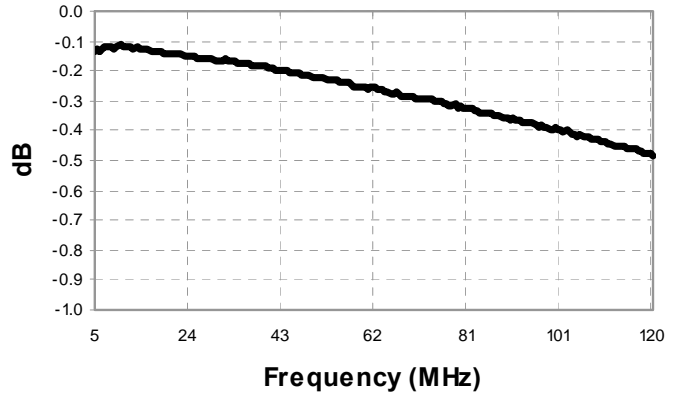

Amplitude Balance

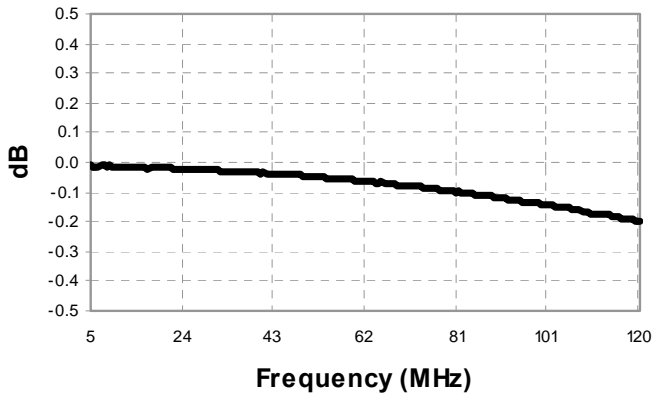

Phase Balance

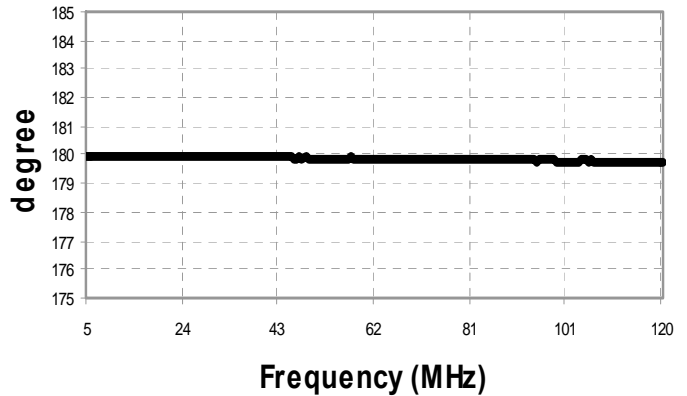

Return Loss: Input

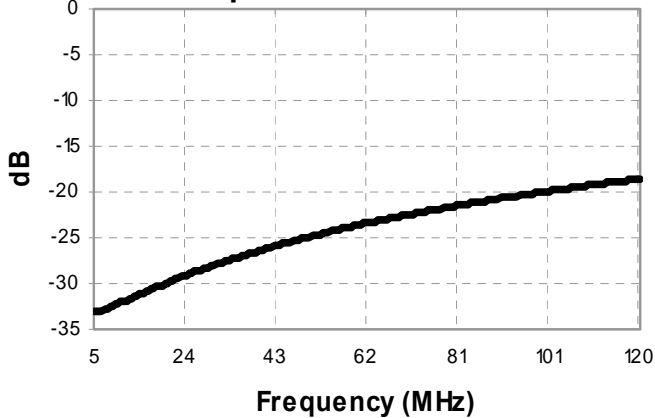

ADVANCED: Data Sheets contain information regarding a product M/A-COM Technology Solutions is considering for development. Performance is based on target specifications, simulated results, and/or prototype measurements. Commitment to develop is not guaranteed.
PRELIMINARY: Data Sheets contain information regarding a product M/A-COM Technology Solutions has under development. Performance is based on engineering tests. Specifications are typical. Mechanical outline has been fixed. Engineering samples and/or test data may be available. Commitment to produce in volume is not guaranteed.

• North America Tel: 800.366.2266 • Europe Tel: +353.21.244.6400
 • India Tel: +91.80.4155721 • China Tel: +86.21.2407.1588
 Visit www.macomtech.com for additional data sheets and product information.

M/A-COM Technology Solutions Inc. and its affiliates reserve the right to make changes to the product(s) or information contained herein without notice.