

Features

- Attenuation: 1 dB steps to 31.5 dB
- Temperature Stability: ± 0.18 dB from -55°C to $+85^{\circ}\text{C}$ Typical
- Low DC Power Consumption
- Hermetic Surface Mount Package
- Integral TTL Driver
- 50 Ohm Nominal Impedance

Description

M/A-COM's AT-107 is a GaAs FET 6-bit digital attenuator with a 1 dB minimum step size and 31.5 dB total attenuation. This attenuator and integral TTL driver is in a hermetically sealed ceramic 24-lead surface mount package. The AT-107 is ideally suited for use where accuracy, fast switching, very low power consumption and low intermodulation products are required. Typical applications include dynamic range setting in precision receiver circuits and other gain/leveling control circuits. Environmental screening is available. Contact the factory for information.

CR-13

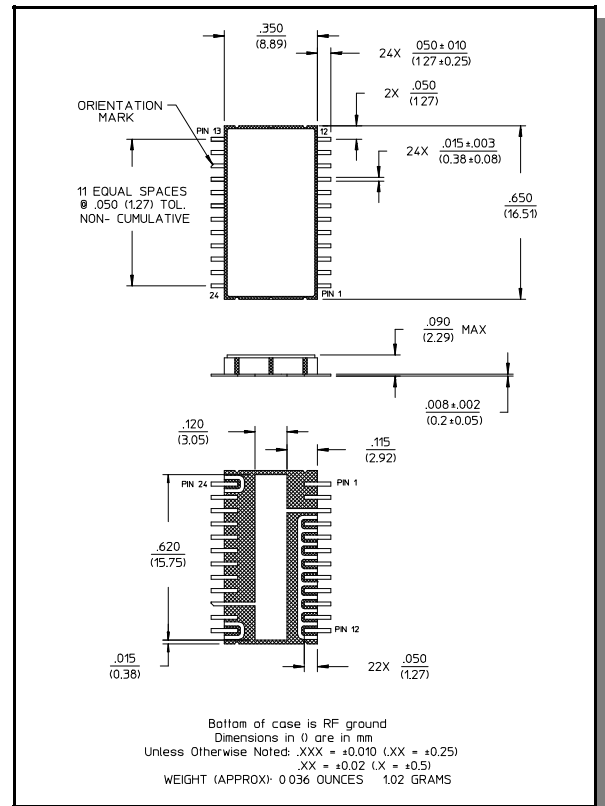

Electrical Specifications: $T_A = -55^{\circ}\text{C}$ to $+85^{\circ}\text{C}$ ¹

Parameter	Test Conditions	Frequency	Units	Min	Typ	Max
Reference Insertion Loss	—	DC - 0.5 GHz	dB	—	—	3.2
		DC - 1.0 GHz	dB	—	—	3.6
		DC - 2.0 GHz	dB	—	—	4.0
Attenuation Accuracy ²	Any Single Bit	DC - 1.0 GHz	dB	$\pm (0.15 + 3\%$ of atten. setting in dB)		
	Any Combination of Bits	DC - 2.0 GHz		$\pm (0.2 + 3\%$ of atten. setting in dB)		
		DC - 1.0 GHz		$\pm (0.2 + 3\%$ of atten. setting in dB) or ± 0.4 dB, whichever is greater		
		DC - 2.0 GHz		$\pm (0.2 + 3\%$ of atten. setting in dB) or ± 0.4 dB, whichever is greater		
VSWR	—	DC - 2.0 GHz	Ratio	—	—	1.8:1
Trise, Tfall	10% to 90%	—	ns	—	9	—
Ton, Toff	50% Control to 90/10% RF	—	ns	—	45	—
Transients	In-Band (peak-peak)	—	mV	—	40	—
1 dB Compression	Input Power Input Power	0.05 GHz	dBm	—	+21	—
		0.5 - 2.0 GHz	dBm	—	+29	—
Input IP3	For two-tone Input Power Up to +5 dBm	0.05 GHz	dBm	—	+35	—
		0.5 - 2.0 GHz	dBm	—	+48	—
Input IP2	For two-tone Input Power Up to +5 dBm	0.05 GHz	dBm	—	+75	—
		0.5 - 2.0 GHz	dBm	—	+79	—

1. All specifications apply when operated with bias voltages of +5V for Vcc and -5.0V for Vee.
 2. This attenuator is guaranteed monotonic.

Electrical Specifications: $T_A = -55^{\circ}\text{C}$ to $+85^{\circ}\text{C}$

Parameter	Test Conditions	Frequency	Units	Min	Typ	Max
Vcc	—	—	V	4.5	5.0	5.5
Vee	—	—	V	-8.0	—	-5.0
Icc	Vcc = 4.5 to 5.5V Vctl = 0 to 0.8V, or Vcc -2.1V to Vcc	—	mA	—	—	6.0
Iee	Vee = -5.0 to -8.0V	—	mA	—	—	1.0
Vctl	Logic 0 (TTL)	—	V	0.0	—	0.8
Vctl	Logic 1 (TTL)	—	V	2.0	—	5.0
Input Leakage Current (Low)	0 to 0.8V	—	μA	—	—	1.0
Input Leakage Current (High)	2.0 to 5.0V	—	μA	—	—	1.0

Absolute Maximum Ratings ³

Parameter	Absolute Maximum
Max Input Power 0.5 GHz 0.5 - 2.0 GHz	+27 dBm +34 dBm
Supply Voltages Vcc Vee	+5.5V -8.5V
Control Voltage ⁴	-0.5V to Vcc +0.5V
Operating Temperature	-55°C to +125°C
Storage Temperature	-65°C to +150°C

- Operation of this device above any one of these parameters may cause permanent damage.
- Standard CMOS TTL interface, latch-up will occur if logic signal is applied prior to power supply.

Truth Table

Control Inputs						
C6	C5	C4	C3	C2	C1	Attenuation
0	0	0	0	0	0	Reference
0	0	0	0	0	1	0.5 dB
0	0	0	0	1	0	1 dB
0	0	0	1	0	0	2 dB
0	0	1	0	0	0	4 dB
0	1	0	0	0	0	8 dB
1	0	0	0	0	0	16 dB
1	1	1	1	1	1	31.5 dB

0 = TTL Low 1 = TTL High

Functional Schematic (Top View)

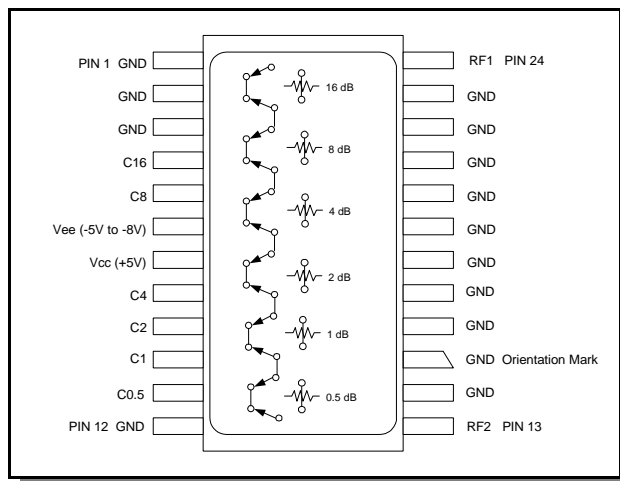

Specifications subject to change without notice.

- North America: Tel. (800) 366-2266
- Asia/Pacific: Tel. +81-44-844-8296, Fax +81-44-844-8298
- Europe: Tel. +44 (1344) 869 595, Fax +44 (1344) 300 020

Visit www.macom.com for additional data sheets and product information.

Typical Performance Curves

Insertion Loss vs. Frequency

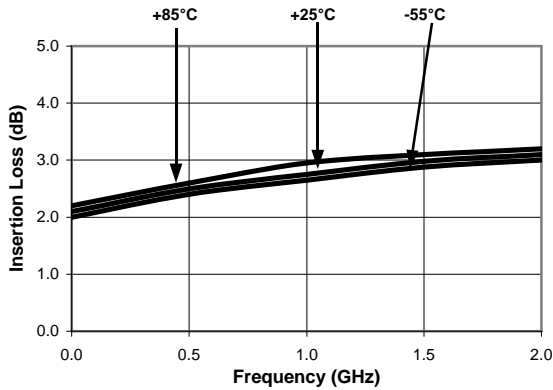

Attenuation Accuracy vs. Frequency

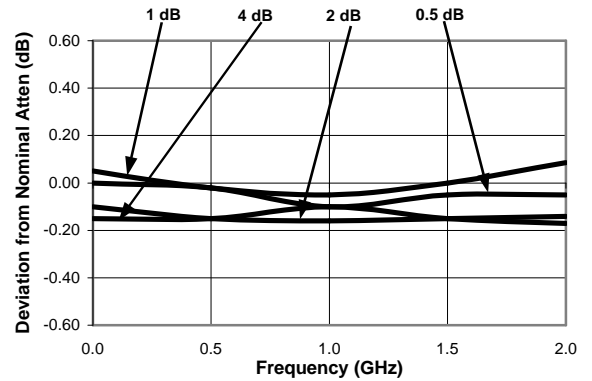

Attenuation Accuracy vs. Frequency

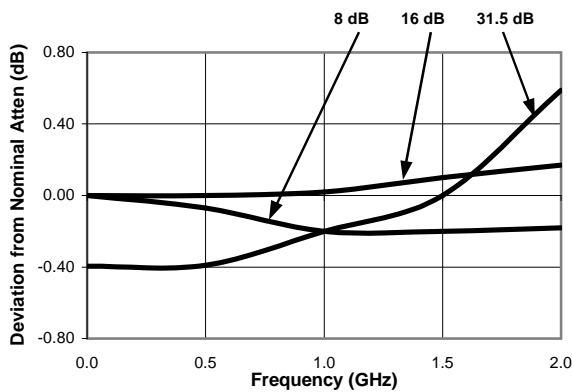

RF1 VSWR vs. Frequency

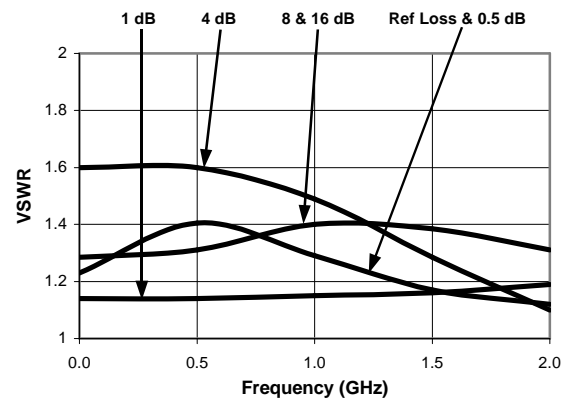

RF2 VSWR vs. Frequency

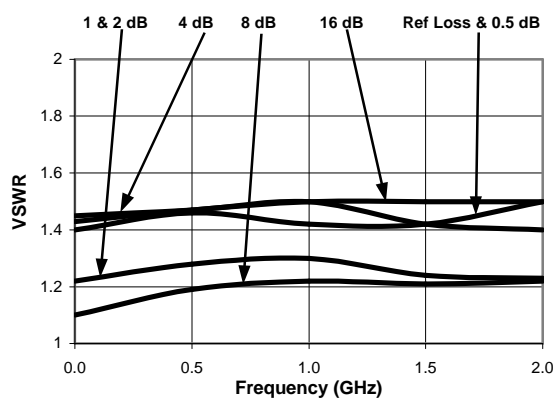

Ordering Information

Part Number	Package
AT-107 PIN	CR-13

Specifications subject to change without notice.

- North America: Tel. (800) 366-2266
- Asia/Pacific: Tel.+81-44-844-8296, Fax +81-44-844-8298
- Europe: Tel. +44 (1344) 869 595, Fax+44 (1344) 300 020

Visit www.macom.com for additional data sheets and product information.