

350mA, LED Lighting Driver

UM1350 SOT23-5

General Description

The UM1350 is capable of driving single or multiple series connected LEDs efficiently from a voltage source higher than the LED voltage. This step-down converter provides an externally adjustable output current of up to 350mA from an input supply between 6V and 30V. It can even reach 8 watts of output power, depending on supply voltage and external components. The UM1350 consists of an output switch and a high-side output current sensing circuit that uses an external resistor to set the nominal average output current. Through applying an external control signal to the ADJ pin, it can adjust the output current to above or below the set value. The ADJ pin will accept either a DC voltage or a PWM waveform to provide a continuous or a gated output current. The chip contains a PWM filter which provides a soft-start feature by controlling the rise of input/output current. It can raise the soft-start by using an external capacitor from the ADJ pin to ground. Applying a voltage of 0.2V or lower to the ADJ pin turns the output off and switches the device into a low current standby state.

The UM1350 is available in a low profile SOT23-5 package.

Applications

- MR16 and general lighting
- Automotive lighting
- Low voltage industrial lighting
- LED back lighting
- Illuminated signs

Features

- Built in thermal and over current shut down.
- Internal 30V NDMOS switch
- 350mA output current
- Single pin on/off and dimming control using DC voltage or PWM at ADJ pin.
- Internal PWM filter
- Soft-start
- High efficiency (up to 95%)
- Wide input voltage range: 6V to 30V
- 40V transient capability
- Output shutdown
- Up to 1MHz switching frequency
- Inherent open-circuit LED protection
- Typical 5% output current accuracy

Pin Configurations

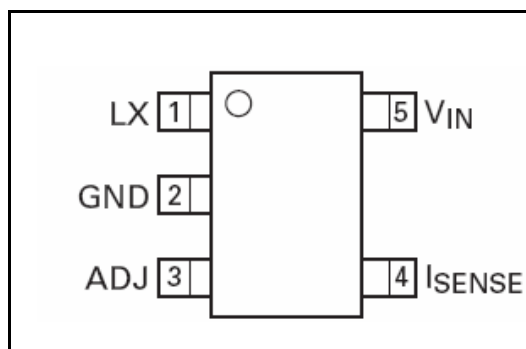

Top View

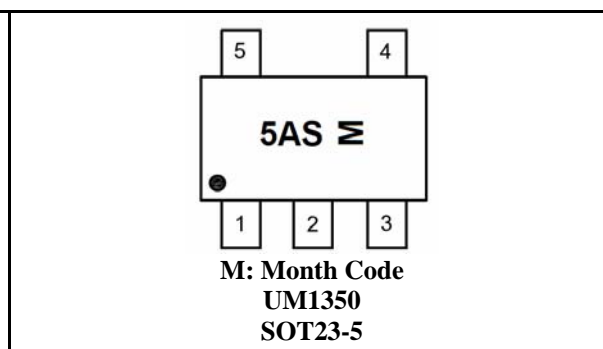

Ordering Information

Part Number	Packaging Type	Marking Code	Shipping Qty
UM1350	SOT23-5	5AS	3000pcs/7Inch Tape & Reel

Pin Description

Pin Number	Symbol	Function
1	LX	Drain of NDMOS switch.
2	GND	Ground (0V).
3	ADJ	Multi-function On/Off and brightness control pin: <ul style="list-style-type: none"> • Leave floating for normal operation. ($V_{ADJ} = V_{REF}$ giving nominal average output current $I_{OUTnom} = 100mV/R_S$) • Drive to voltage below 0.2V to turn off output current • Drive with DC voltage ($0.3V < V_{ADJ} < 2.5V$) to adjust output current from 25% to 200% of I_{OUTnom} • Drive with PWM signal from open-collector or open-drain transistor, to adjust output current. Adjustment range 25% to 100% of I_{OUTnom} for $f > 10kHz$ and 1% to 100% of I_{OUTnom} for $f < 500Hz$ <ul style="list-style-type: none"> • Connect a capacitor from this pin to ground to increase soft-start time. (Default soft-start time = 0.5ms. Additional soft-start time is approx. 0.25ms/nF)
4	I_{SENSE}	Connect resistor R_S from this pin to V_{IN} to define nominal average output current ($I_{OUTnom} = 100mV/R_S$)
5	V_{IN}	Input Voltage

Absolute Maximum Ratings (Note 1)

Symbol	Parameter	Value	Unit
V_{IN}	Input Voltage	-0.3 to +30	V
V_{SENSE}	I_{SENSE} Voltage	+0.3 to -5 (Note 2)	V
V_{LX}	LX Output Voltage	-0.3 to +30	V
V_{ADJ}	Adjust Pin Input Voltage	-0.3 to +6	V
I_{LX}	Switch Output Current	500	mA
P_D	Power Dissipation	450	mW
T_J	Operating Junction Temperature	-40 to +120	°C
T_{STG}	Storage Temperature Range	-55 to +150	°C

Note 1: These are stress ratings only. Operation above the absolute maximum rating may cause device failure. Operation at the absolute maximum ratings, for extended periods, may reduce device reliability.

Note 2: This voltage is measured with respect to V_{IN} .

Electrical Characteristics

 ($V_{IN}=12V$, $T_A=25^{\circ}C$, unless otherwise noted.)

Symbol	Parameter	Test Conditions	Min	Typ	Max	Unit
V_{IN}	Input Voltage Range		6		30	V
V_{SU}	Internal Regulator Start-up Threshold	V_{IN} Rising		4.8		V
I_{INQoff}	Quiescent Supply Current with Output off	ADJ Pin Grounded		40		μA
I_{INQon}	Quiescent Supply Current with Output Switching	ADJ Pin Floating $f=250kHz$		220		μA
V_{SENSE}	Mean Current Sense Threshold Voltage (define LED current setting accuracy)	Measured on I_{SENSE} Pin with respect to V_{IN} $V_{ADJ}=1.25V$	95	100	105	mV
$V_{SENSEHYS}$	Sense Threshold Hysteresis			$\pm 15\%$		
I_{SENSE}	I_{SENSE} pin input current	$V_{SENSE} = V_{IN} - 0.1$		3.0	10	μA
V_{REF}	Internal Reference Voltage	Measured on ADJ Pin with Pin Floating	1.20	1.25	1.30	V
V_{ADJ}	External Control Voltage Range on ADJ pin for DC Brightness Control (Note 3)		0.3		2.5	V
V_{ADJoff}	DC voltage on ADJ pin to switch device from active (on) state to quiescent (off) state	V_{ADJ} falling	0.15	0.20	0.25	V
V_{ADJon}	DC voltage on ADJ pin to switch device from quiescent (off) state to active (on) state	V_{ADJ} rising	0.20	0.25	0.30	V
R_{ADJ}	Resistance between ADJ pin and V_{REF}		135		250	$k\Omega$
I_{LXmean}	Continuous LX switch current				0.37	A
R_{LX}	LX Switch 'On' resistance			1.2	2	Ω
$I_{LX(leak)}$	LX switch leakage current				1	μA

Note 3: 100% brightness corresponds to $V_{ADJ}=V_{ADJ(nom)}=V_{REF}$. Driving the ADJ pin above V_{REF} will increase the V_{SENSE} threshold and output current proportionally.

Block Diagram

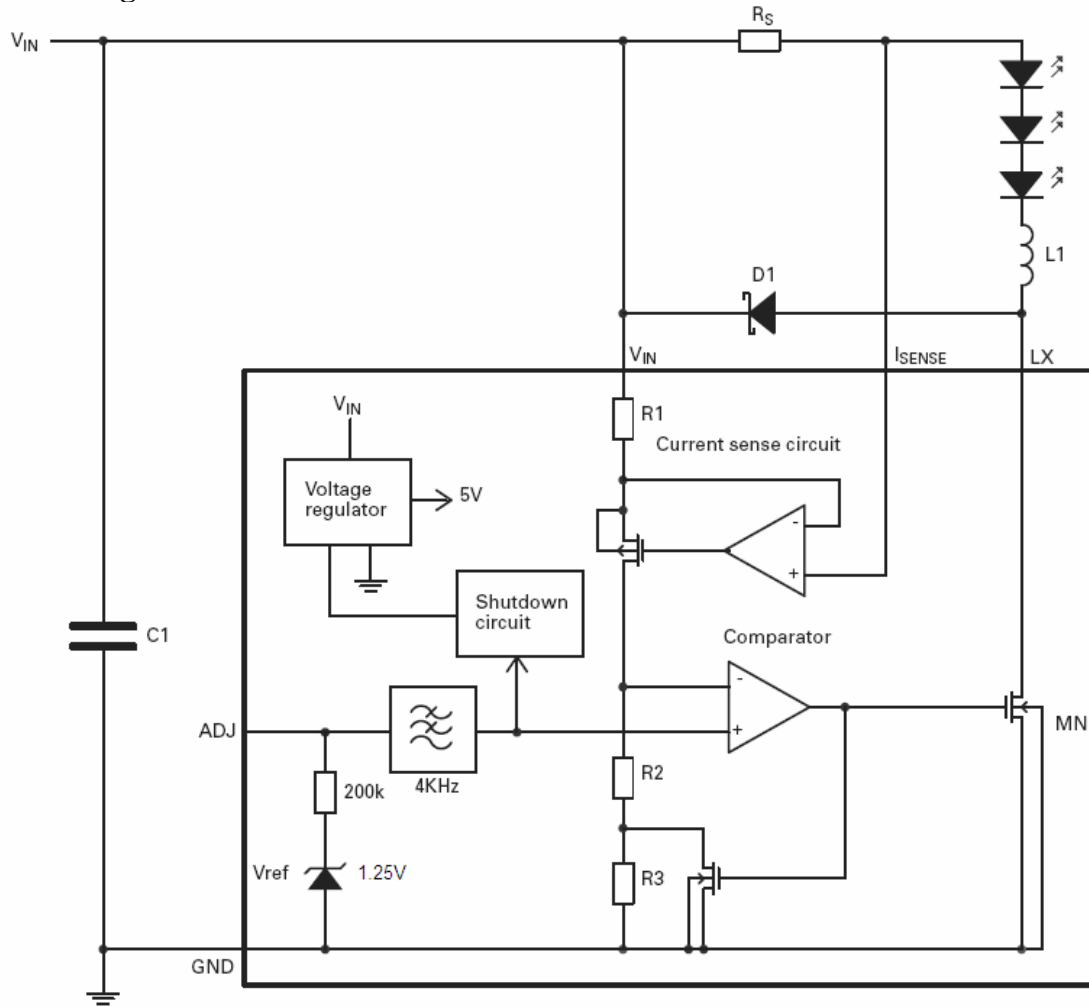

Typical Application Circuit

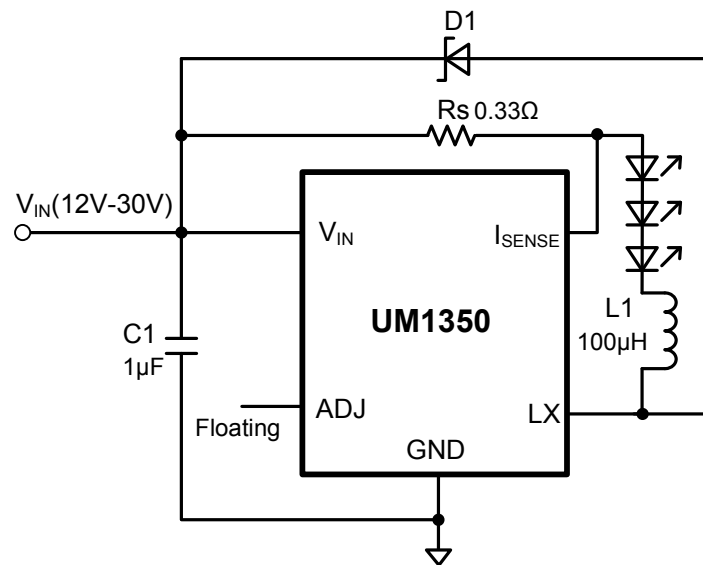

Device description

The device, in conjunction with the coil (L1) and current sense resistor (R_S), forms a self-oscillating continuous-mode buck converter.

Device operation (Refer to block diagram (page 5) and Figure 1 (page 6) - Operating waveforms)

Operation can be best understood by assuming that the ADJ pin of the device is unconnected and the voltage on this pin (V_{ADJ}) appears directly at the (+) input of the comparator.

When input voltage V_{IN} is first applied, the initial current in L1 and R_S is zero and there is no output from the current sense circuit. Under this condition, the (-) input to the comparator is at ground and its output is high. This turns MN on and switches the LX pin low, causing current to flow from V_{IN} to ground, via R_S , L1 and the LED(s). The current rises at a rate determined by V_{IN} and L1 to produce a voltage ramp (V_{SENSE}) across R_S . The supply referred voltage V_{SENSE} is forced across internal resistor R1 by the current sense circuit and produces a proportional current in internal resistors R2 and R3. This produces a ground referred rising voltage at the (-) input of the comparator. When this reaches the threshold voltage (V_{ADJ}), the comparator output switches low and MN turns off. The comparator output also drives another NMOS switch, which bypasses internal resistor R3 to provide a controlled amount of hysteresis. The hysteresis is set by R3 to be nominally 15% of V_{ADJ} .

When MN is off, the current in L1 continues to flow via D1 and the LED(s) back to V_{IN} . The current decays at a rate determined by the LED and diode forward voltages to produce a falling voltage at the input of the comparator. When this voltage returns to V_{ADJ} , the comparator output switches high again. This cycle of events repeats, with the comparator input ramping between limits of $V_{ADJ} \pm 15\%$.

Switching thresholds

With $V_{ADJ}=V_{REF}$, the ratios of R1, R2 and R3, define an average V_{SENSE} switching threshold of 100mV (measured on the I_{SENSE} pin with respect to V_{IN}). The average output current I_{OUTnom} is then defined by this voltage and R_S according to:

$$I_{OUTnom}=100mV/R_S$$

Nominal ripple current is $\pm 15mV/R_S$

Adjusting output current

The device contains a low pass filter between the ADJ pin and the threshold comparator and an internal current limiting resistor (200k nom) between ADJ and the internal reference voltage. This allows the ADJ pin to be overdriven with either DC or pulse signals to change the V_{SENSE} switching threshold and adjust the output current. The filter is third order, comprising three sections, each with a cut-off frequency of nominally 4kHz.

Details of the different modes of adjusting output current are given in the applications section.

Output shutdown

The output of the low pass filter drives the shutdown circuit. When the input voltage to this circuit falls below the threshold (0.2V nom), the internal regulator and the output switch are turned off. The voltage reference remains powered during shutdown to provide the bias current for the shutdown circuit. Quiescent supply current during shutdown is nominally 40 μ A and switch leakage is below 1 μ A.

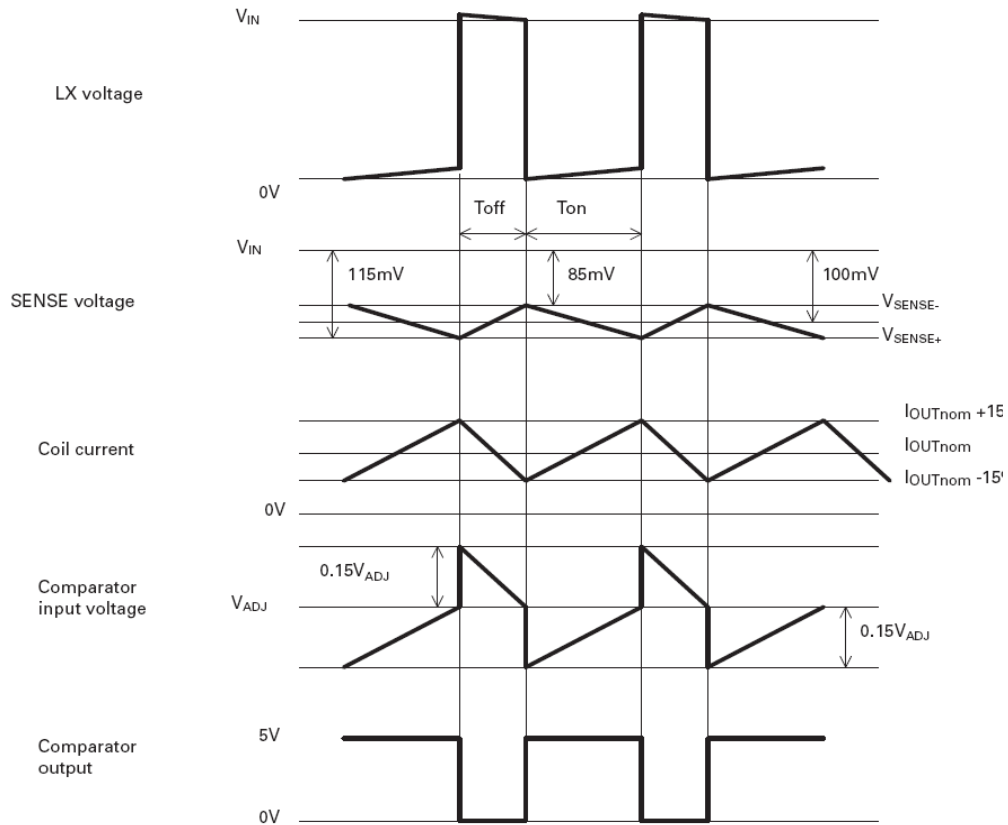
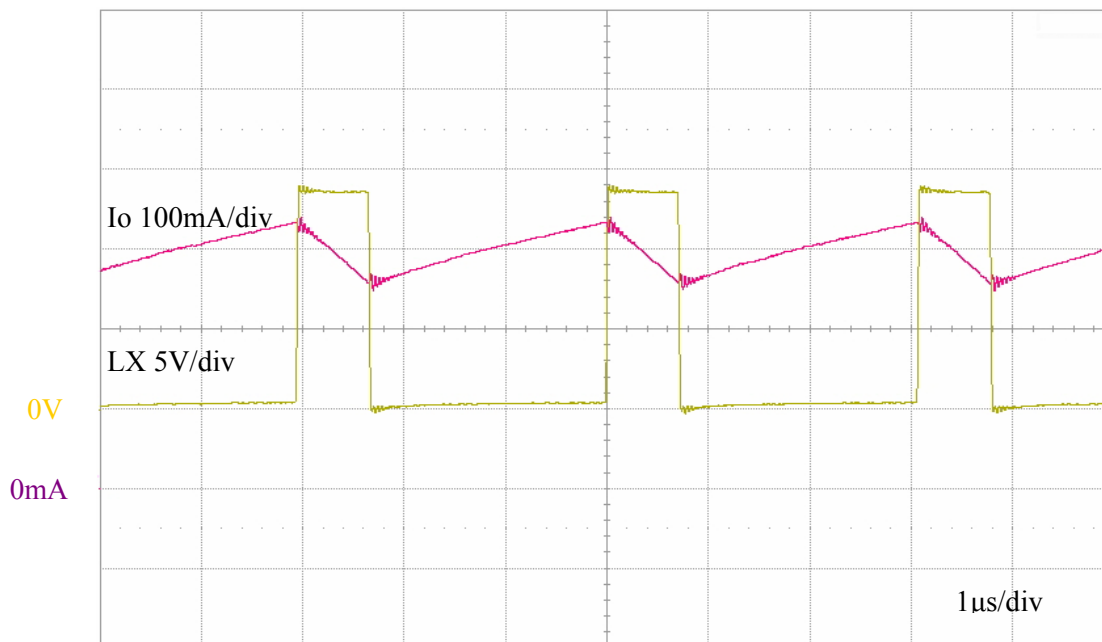

Figure 1 Operating Waveforms

Typical Operating Waveforms
($V_{in}=12V$, $L=100\mu H$, $R_s=0.33\Omega$, 3LED)

Normal Operation: Output Current and LX Voltage



Typical Operating Characteristics

($V_{IN}=12V$, $T_A=25^\circ C$, unless otherwise noted)

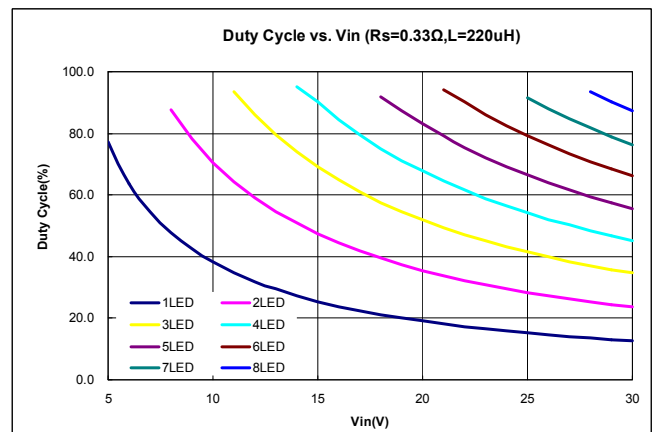
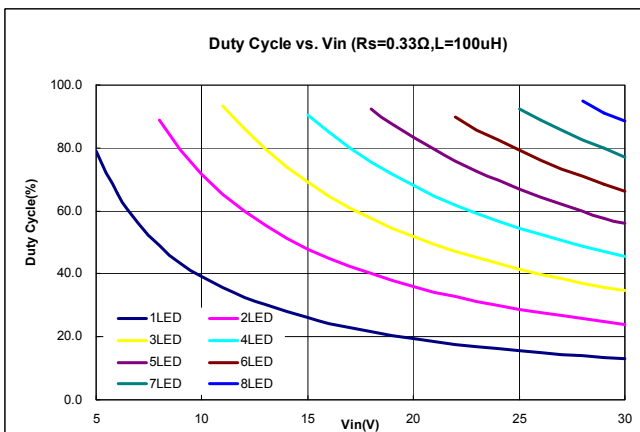
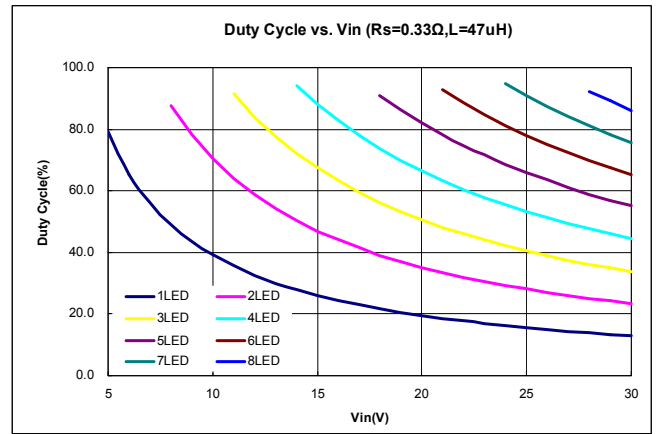
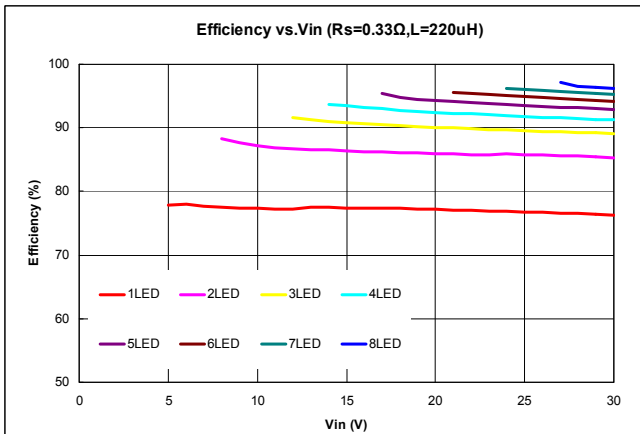
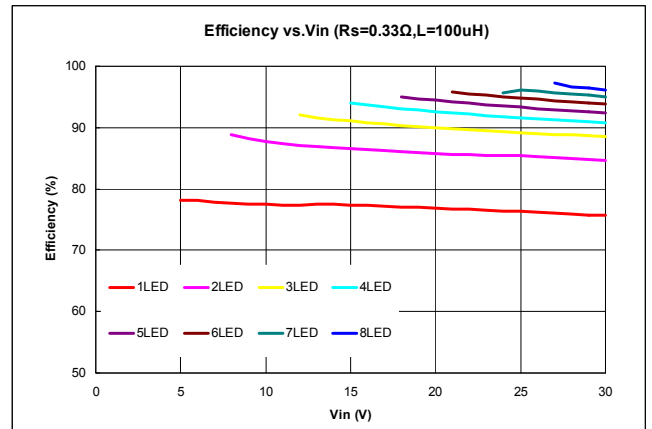
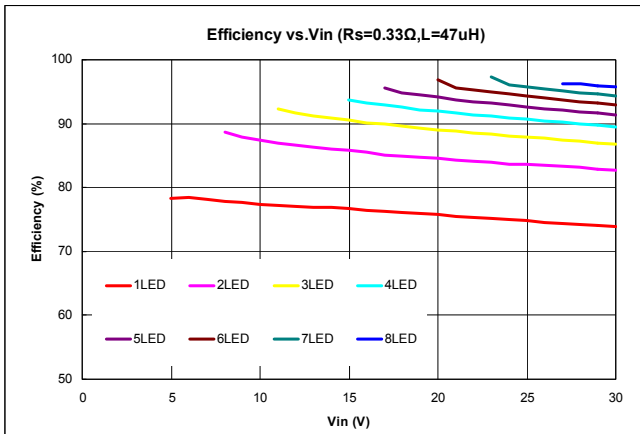

Typical Operating Characteristics (Continued)

($V_{IN}=12V$, $T_A=25^\circ C$, unless otherwise noted)

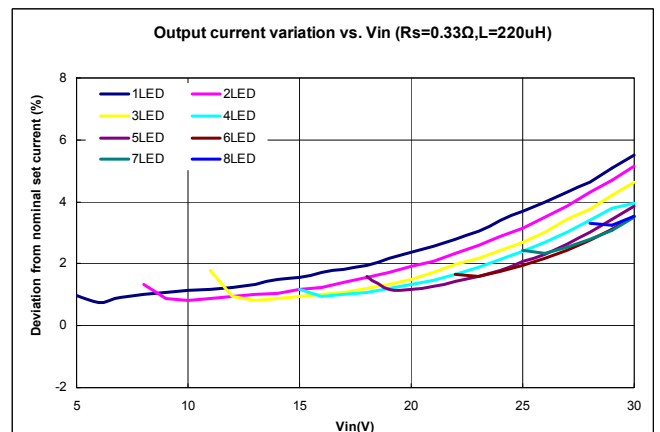
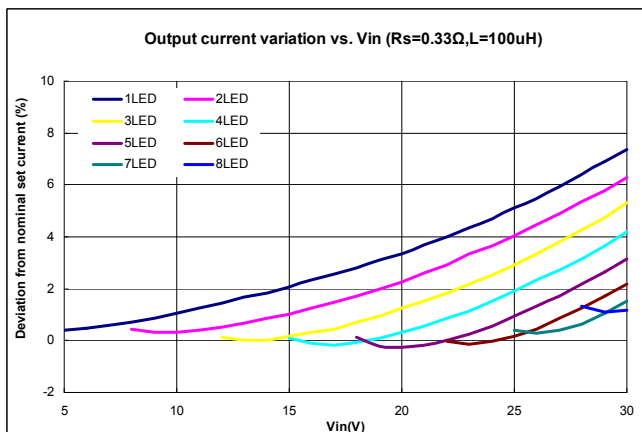
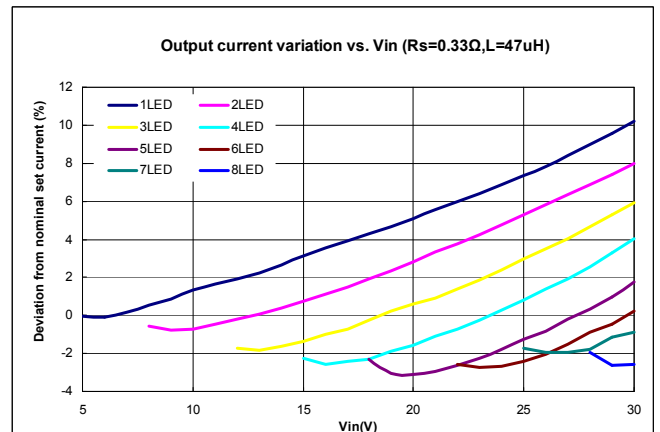
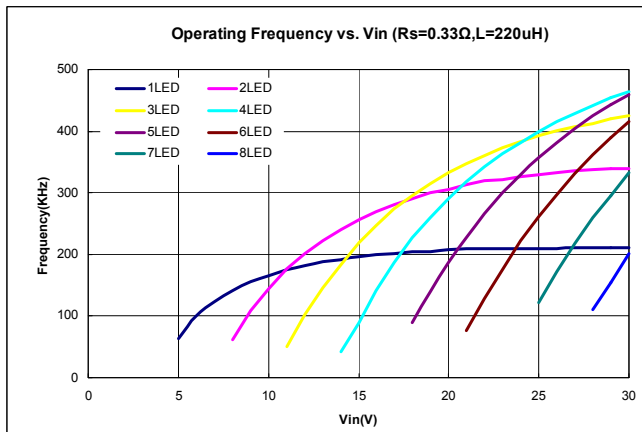
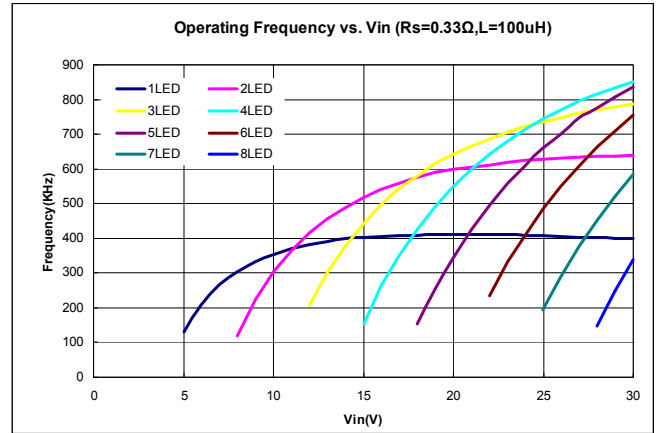
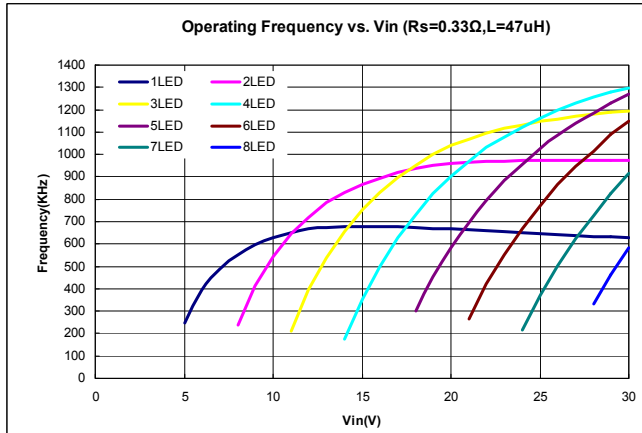

Typical Operating Characteristics (Continued)
($V_{IN}=12V$, $T_A=25^\circ C$, unless otherwise noted)

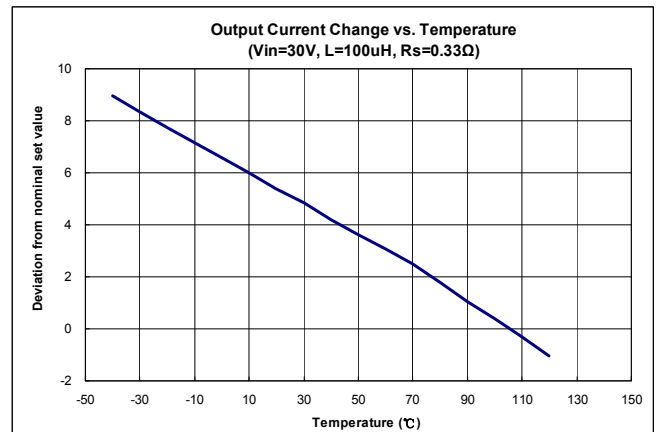
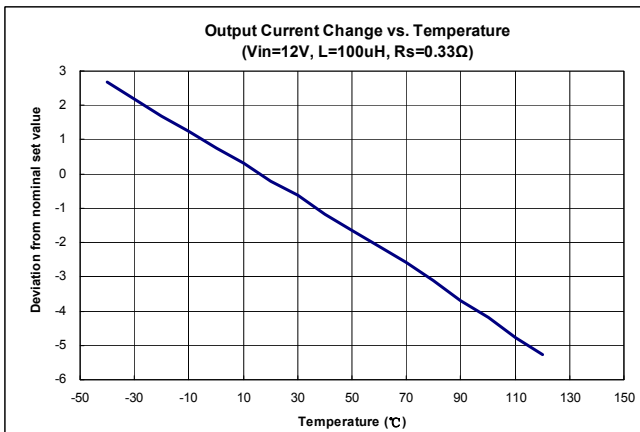
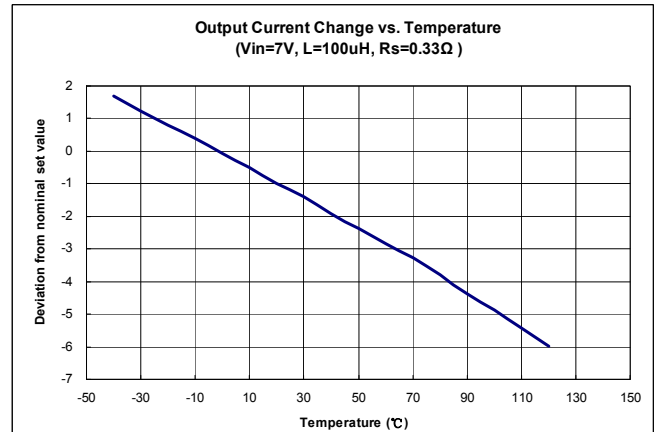
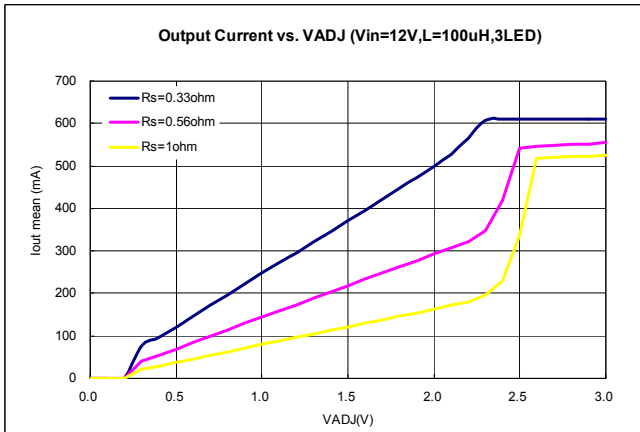
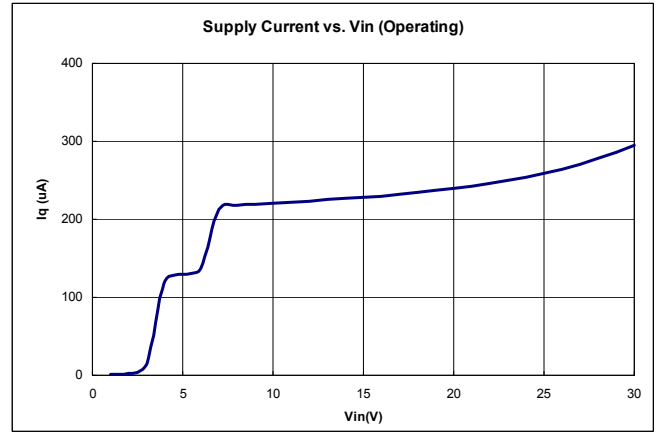
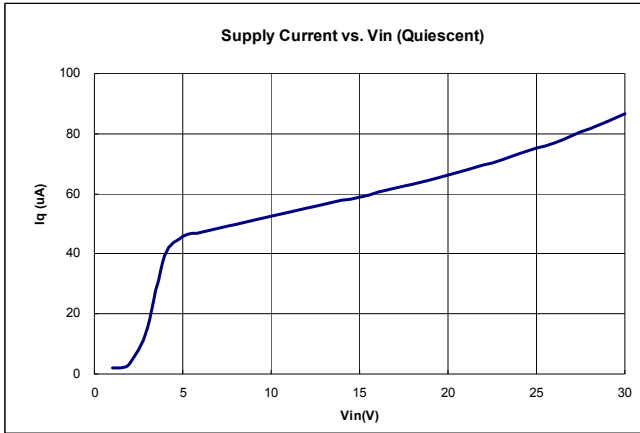

Typical Operating Characteristics (Continued)

($V_{IN}=12V$, $T_A=25^{\circ}C$, unless otherwise noted)

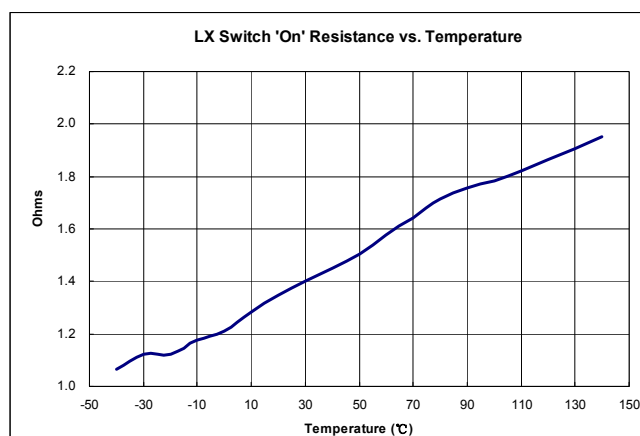
Applications Information
Setting nominal average output current with external resistor R_S

The nominal average output current in the LED(s) is determined by the value of the external current sense resistor (R_S) connected between V_{IN} and I_{SENSE} and is given by:

$$I_{OUTnom} = 0.1 / R_S \quad (R_S \geq 0.27\Omega)$$

The table below gives values of nominal average output current for several preferred values of current setting resistor (R_S) in the typical application circuit shown on page 5:

R_S (Ω)	Nominal average output current (mA)
0.27	370
0.3	333
0.33	300
0.39	256

The above values assume that the ADJ pin is floating and at a nominal voltage of V_{REF} . Note that $R_S=0.27\Omega$ is the minimum allowed value of sense resistor under these conditions to maintain switch current below the specified maximum value.

Output current adjustment by external DC control voltage

The ADJ pin can be driven by an external dc voltage, as shown, to adjust the output current to a value below the nominal average value defined by R_S .

The average output current is given by:

$$I_{OUT} = (0.08 * V_{ADJ}) / R_S \quad [\text{for } 0.3V < V_{ADJ} < 2.5V]$$

Note that 100% brightness setting corresponds to $V_{ADJ} = V_{REF}$. When driving the ADJ pin above 1.25V, R_S must be increased in proportion to prevent I_{OUTdc} exceeding 370mA maximum.

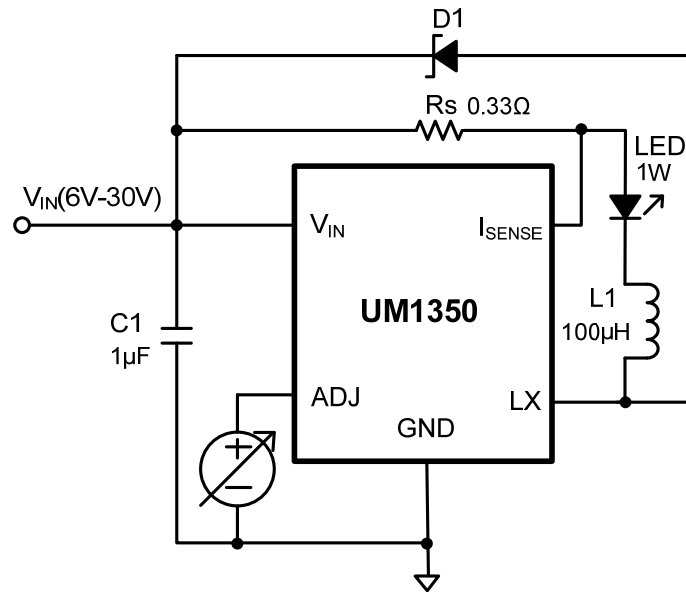

Output current adjustment by PWM control

A Pulse Width Modulated (PWM) signal with duty cycle PWM can be applied to the ADJ pin, as shown below, to adjust the output current to a value below the nominal average value set by resistor R_S :

$$I_{OUT} = (V_{pulse} * 0.1 * D) / (1.25 * R_S) \quad (0 \leq D \leq 100\%, 0.3V < V_{pulse} < 2.5V)$$

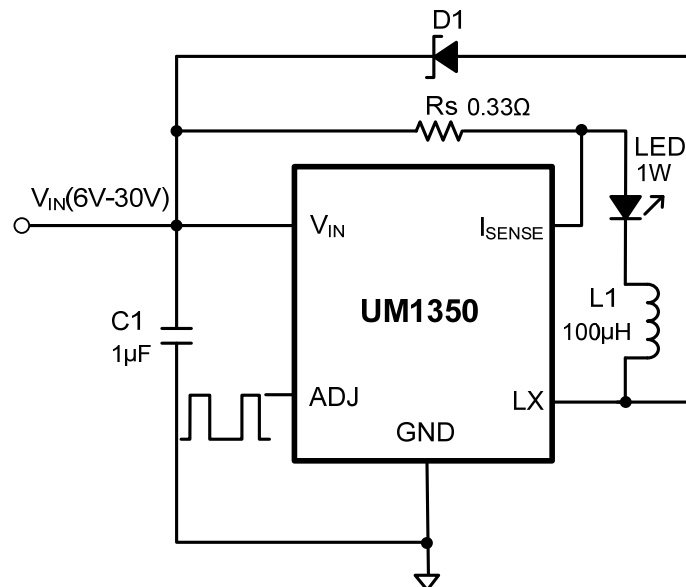

PWM dimming provides reduced brightness by modulating the LED's forward current between 0% and 100%. The LED brightness is controlled by adjusting the relative ratios of the on time to the off time. A 25% brightness level is achieved by turning the LED on at full current for 25% of one cycle. To ensure this switching process between on and off state is invisible by human eyes, the switching frequency must be greater than 100 Hz. Above 100 Hz, the human eyes average the on and off times, seeing only an effective brightness that is proportional to the LED's on-time duty cycle. The advantage of PWM dimming is that the forward current is always constant, therefore the LED color does not vary with brightness as it

does with analog dimming. Pulsing the current provides precise brightness control while preserving the color purity.

Capacitor selection

A low ESR capacitor should be used for input decoupling, as the ESR of this capacitor appears in series with the supply source impedance and lowers overall efficiency. This capacitor has to supply the relatively high peak current to the coil and smooth the current ripple on the input supply. A minimum value of 1 μ F is acceptable if the input source is close to the device, but higher values will improve performance at lower input voltages, especially when the source impedance is high. The input capacitor should be placed as close as possible to the IC.

For maximum stability over temperature and voltage, capacitors with X7R, X5R, or better dielectric are recommended. Capacitors with Y5V dielectric are not suitable for decoupling in this application and should NOT be used.

Inductor selection

Recommended inductor values for the UM1350 are in the range 47 μ H to 220 μ H. Higher values of inductance are recommended at lower output current in order to minimize errors due to switching delays, which result in increased ripple and lower efficiency. Higher values of inductance also result in a smaller change in output current over the supply voltage range.

The inductor should be mounted as close to the device as possible with low resistance connections to the LX and V_{IN} pins. The chosen coil should have a saturation current higher than the peak output current and a continuous current rating above the required mean output current.

The inductor value should be chosen to maintain operating duty cycle and switch 'on'/'off' times within the specified limits over the supply voltage and load current range. The following equations can be used as a guide.

SW Switch 'On' time

$$T_{ON} = (L * \Delta I) / (V_{IN} - V_{LED} - I_{LED} * (R_S + R_L + R_{LX}))$$

SW Switch 'Off' time

$$T_{OFF} = (L * \Delta I) / (V_{LED} + V_D + I_{LED} * (R_S + R_L))$$

Where:

L is the coil inductance (H)

R_L is the coil resistance (Ω)

R_S is the current sense resistance (Ω)

I_{LED} is the required LED current (A)

ΔI is the coil peak-peak ripple current (A) {Internally set to $0.3 \times I_{LED}$ }

V_{IN} is the supply voltage (V)

V_{LED} is the total LED forward voltage (V)

R_{LX} is the switch resistance (Ω)

V_D is the diode forward voltage at the required load current (V)

Diode selection

For maximum efficiency and performance, the rectifier (D1) should be a fast low capacitance Schottky diode with low reverse leakage at the maximum operating voltage and temperature.

They also provide better efficiency than silicon diodes, due to a combination of lower forward voltage and reduced recovery time.

It is important to select parts with a peak current rating above the peak coil current and a continuous current rating higher than the maximum output load current. It is very important to consider the reverse leakage of the diode when operating above 85°C. Excess leakage will increase the power dissipation in the device and if close to the load may create a thermal runaway condition.

The higher forward voltage and overshoot due to reverse recovery time in silicon diodes will increase the peak voltage on the LX output. If a silicon diode is used, care should be taken to ensure that the total voltage appearing on the LX pin including supply ripple, does not exceed the specified maximum value.

PCB Layout Guidelines

Careful PCB layout is critical to achieve low switching losses and stable operation. Minimize ground noise by connecting high current ground returns, the input bypass capacitor ground lead, and the output filter ground lead to a single point. Place R_s as close as possible to the I_{sense} and V_{IN} . For better noise immunity, a Kelvin connection is strongly recommended between I_{sense} and R_s .

Package Information

UM1350 SOT23-5

Outline Drawing

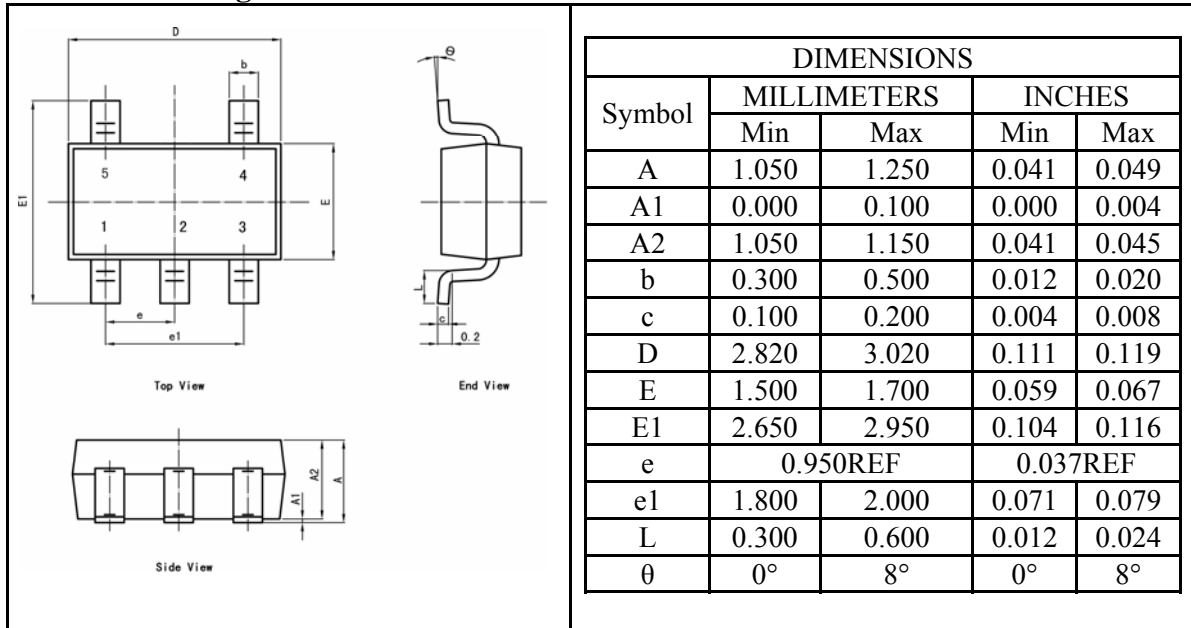

Land Pattern

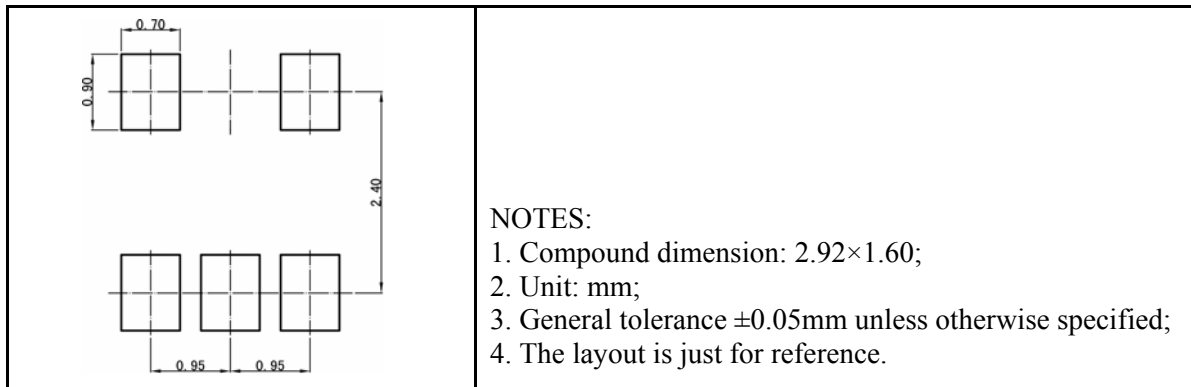

Tape and Reel Orientation



IMPORTANT NOTICE

The information in this document has been carefully reviewed and is believed to be accurate. Nonetheless, this document is subject to change without notice. Union assumes no responsibility for any inaccuracies that may be contained in this document, and makes no commitment to update or to keep current the contained information, or to notify a person or organization of any update. Union reserves the right to make changes, at any time, in order to improve reliability, function or design and to attempt to supply the best product possible.



Union Semiconductor, Inc

Add: 2F, No. 3, Lane 647 Songtao Road, Shanghai 201203

Tel: 021-51093966

Fax: 021-51026018

Website: www.union-ic.com