

FEATURES

Analog performance

- 160 kSPS, 16-bit, precision analog-to-digital converter (ADC)
- 4 dedicated voltage measurement channels
- 8 current measurement channels
- Impedance measurement engine

High precision voltage reference

Supply noise rejection filtering

Ultralow leakage configurable switch matrix

12-bit digital-to-analog converter (DAC)

Precision instrumentation amplifier control loop

6-channel CapTouch controller

Temperature sensor

Analog hardware accelerators

Autonomous analog front-end (AFE) controller

Independent sequencer for AFE functions

Direct digital synthesizer (DDS)/arbitrary waveform generator

Receive filters

Complex impedance measurement (DFT) engine

Processing

- 16 MHz ARM Cortex-M3 processor
- 384 kB of embedded flash memory
- 32 kB system SRAM
- 16 kB Flash configured EEPROM

Integrated full-speed USB 2.0 controller and PHY

Multilayer advanced microcontroller bus architecture (AMBA) bus matrix

Central direct memory access (DMA) controller

Real-time clock (RTC)

General-purpose, wake-up, and watchdog timers

Communication

Input/output

I²S and beeper interface

LCD display controller (parallel and serial)

LCD segment controller

SPI, I²C, and UART peripheral interfaces

Programmable GPIOs

Power

Coin cell battery compatible

2.5 V to 3.6 V active measurement range

Power management unit (PMU)

Power-on reset (POR) and power supply monitor (PSM)

Packages and temperature range

Operating temperature range: -40°C to +85°C

Package: 120-lead, 8 mm × 8 mm CSP_BGA

APPLICATIONS

Point-of-care diagnostics

Body-worn devices for monitoring vital signs

Amperometric, voltametric, and impedometric measurements

FUNCTIONAL BLOCK DIAGRAM

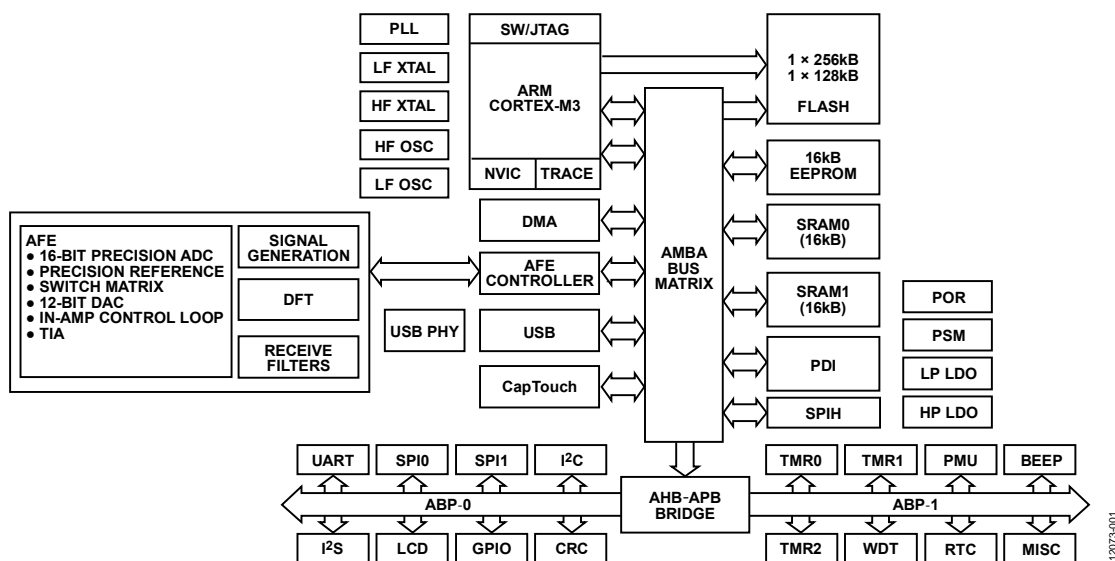

Figure 1.

12073-901

Rev. A

Document Feedback

Information furnished by Analog Devices is believed to be accurate and reliable. However, no responsibility is assumed by Analog Devices for its use, nor for any infringements of patents or other rights of third parties that may result from its use. Specifications subject to change without notice. No license is granted by implication or otherwise under any patent or patent rights of Analog Devices. Trademarks and registered trademarks are the property of their respective owners.

One Technology Way, P.O. Box 9106, Norwood, MA 02062-9106, U.S.A.

Tel: 781.329.4700

©2014 Analog Devices, Inc. All rights reserved.

Technical Support

www.analog.com

ADUCM350* Product Page Quick Links

Last Content Update: 11/01/2016

[Comparable Parts](#)

View a parametric search of comparable parts

[Evaluation Kits](#)

- ADuCM350 Evaluation Board

[Documentation](#)

Application Notes

- AN-1262: ADuCM350 Serial Download Protocol
- AN-1263: Security Integrity of the ADuCM350
- AN-1271: Optimizing the ADuCM350 for Impedance Conversion
- AN-1281: Amperometric/Potentiostat Measurements Using the ADuCM350
- AN-1282: Profiling the ADuCM350 Supply Current in an Example Application
- AN-1286: ADuCM350 Analog Front End Accuracy in a Noisy Digital Environment
- AN-1293: A Quick Guide to the ADuCM350 Sequencer
- AN-1302: Optimizing the ADuCM350 for 4-Wire, Bio-Isolated Impedance Measurement Applications

Data Sheet

- ADuCM350: 16-Bit Precision, Low Power Meter On A Chip with Cortex-M3 and Connectivity Data Sheet

User Guides

- UG-587: ADuCM350 Hardware Reference Manual
- UG-668: EVAL-ADuCM350EBZ User Guide
- UG-677: ADuCM350 Software Development Kit Quick Start Guide

[Reference Materials](#)

Technical Articles

- Home is Where the Heart Is

[Design Resources](#)

- ADUCM350 Material Declaration
- PCN-PDN Information
- Quality And Reliability
- Symbols and Footprints

[Discussions](#)

View all ADUCM350 EngineerZone Discussions

[Sample and Buy](#)

Visit the product page to see pricing options

[Technical Support](#)

Submit a technical question or find your regional support number

* This page was dynamically generated by Analog Devices, Inc. and inserted into this data sheet. Note: Dynamic changes to the content on this page does not constitute a change to the revision number of the product data sheet. This content may be frequently modified.

TABLE OF CONTENTS

Features	1	Typical Performance Characteristics	25
Applications	1	Analog Front End	30
Functional Block Diagram	1	Excitation Stage	30
Revision History	2	Measurement Stage	32
General Description	3	AFE Control	33
Specifications	4	CapTouch Features	33
Analog Front-End Specifications	4	MicroSubSystem	34
Switch Matrix Specifications	5	Memories	34
Transimpedance Amplifier Specifications	6	Debug Capability	34
ADC Specifications	6	Programmable GPIOs	34
Temperature Sensor Specifications	6	Timers	34
CapTouch	6	USB	34
DFT-Based Impedance Measurements	7	Power Management and Clocking	35
Digital Platform	7	Display Options	35
System Clocks/Timers	10	Audio Options	36
Power Management Specifications	12	Development Support	37
Trickle Charger	12	Documentation	37
Timing Characteristics	13	Hardware	37
Absolute Maximum Ratings	19	Software	37
Thermal Resistance	19	Packaging and Ordering Information	38
ESD Caution	19	Outline Dimensions	38
Pin Configuration and Function Descriptions	20	Ordering Guide	38

REVISION HISTORY

5/14—Revision A: Initial Version

GENERAL DESCRIPTION

The [ADuCM350](#) is a complete, coin cell powered, high precision, meter-on-chip for portable device applications for applications such as point-of-care diagnostics and body-worn devices for monitoring vital signs. The [ADuCM350](#) is designed for high precision amperometric, voltametric, and impedometric measurement capabilities.

The [ADuCM350](#) analog front end (AFE) features a 16-bit, precision, 160 kSPS analog-to-digital converter (ADC); 0.17% precision voltage reference; 12-bit, no missing codes digital-to-analog converter (DAC); and a reconfigurable ultralow leakage switch matrix. The [ADuCM350](#) also includes an ARM® Cortex-M3-based processor, memory, and all I/O connectivity to

support portable meters with display, USB communication, and active sensors. The [ADuCM350](#) is available in a 120-lead, 8 mm × 8 mm CSP_BGA and operates from -40°C to +85°C.

To support extremely low dynamic and hibernate power management, the [ADuCM350](#) provides a collection of power modes and features, such as dynamic and software controlled clock gating and power gating.

The AFE is connected to the ARM Cortex-M3 via an advanced high performance bus (AHB) slave interface on the advanced microcontroller bus architecture (AMBA) matrix, as well as direct memory access (DMA) and interrupt connections.

SPECIFICATIONS

All characterization is at $V_{CCM} = 2.5\text{ V}$ to 3.6 V , specifications below 2.5 V are for functionality only, all minimum and maximum specifications are specified for a temperature range of -40°C to $+85^{\circ}\text{C}$, unless otherwise noted.

ANALOG FRONT-END SPECIFICATIONS

AFE LDO Specifications

Table 1. AFE LDO Specifications

Parameter	Min	Typ	Max	Unit	Test Conditions/Comments
VOLTAGE					
Output Voltage	1.71	1.8	1.89	V	Measured with a load capacitance (C_{LOAD}) = $0.47\ \mu\text{F}$; measured with 1 mA load current on AVDD_RX/TX; all AFE blocks powered down
Dropout		150	200	mV	10 mA load applied; no AFE blocks enabled
REGULATION					
Line		1080		$\mu\text{V/V}$	10 mA load applied
Load		0.65		mV/mA	10 mA load applied
POWER UP					
Power-Up Time		500		μs	Measured with a $C_{LOAD} = 0.47\ \mu\text{F}$; current limit enabled

High Precision Internal Reference Specifications

Table 2. High Precision Internal Reference Specifications

Parameter	Min	Typ	Max	Unit	Test Conditions/Comments
ADC V_{REF}					
Reference Voltage Initial Accuracy ¹	1.797	1.8	1.803	V	For a temperature range of 0°C to 50°C
	1.79	1.8	1.803	V	For a temperature range of -40°C to $+85^{\circ}\text{C}$
Output Impedance			570	$\text{m}\Omega$	LDO and reference enabled; all other AFE blocks disabled; reference loaded with $50\ \mu\text{A}$ on VREF
Temperature Coefficient ²	-52		+90	ppm/ $^{\circ}\text{C}$	For a temperature range of -40°C to $+85^{\circ}\text{C}$, maximum value from -40°C to $+25^{\circ}\text{C}$, and from $+25^{\circ}\text{C}$ to $+85^{\circ}\text{C}$ specified
	-45		+48	ppm/ $^{\circ}\text{C}$	For a temperature range of 0°C to 50°C , maximum value from -40°C to $+25^{\circ}\text{C}$, and from 25°C to 85°C specified
VREF Thermal Hysteresis		50		ppm	
REF_EXCITE Switching Load	1.789	1.793	1.797	V	$I_{LOAD} = 200\ \mu\text{A}$; internal ADC measurement
Line Regulation		50		$\mu\text{V/V}$	$V_{CCM1} = 2.5\text{ V}$, $V_{CCM2} = 3.6\text{ V}$; reference loaded with $300\ \mu\text{A}$
Short-Circuit Current to Ground		10		mA	Current limit off
DAC V_{REF}					
Reference Voltage	1.77	1.8	1.83	V	
VBIAS					
VBIAS Voltage	1.095	1.1	1.102	V	Measured with a $C_{LOAD} = 0.47\ \mu\text{F}$; no current load

¹ Reference voltage is trimmed unloaded. Measured with $C_{LOAD} = 4.7\ \mu\text{F}$. Measured at 25°C .

² Guaranteed by design and/or characterization.

DAC/RCF/PGA Specifications**Table 3. DAC/PGA/RCF Specifications**

Parameter ¹	Min	Typ	Max	Unit	Test Conditions/Comments
DAC					
Output Range	-600		+600	mV	As seen by sensor
Resolution			12	Bits	
Integral Nonlinearity (INL)		±0.85		LSB	Measured at an output of the excitation loop, using gain = 1 and default DAC clock (16 MHz ÷ 49 DAC clock speed)
Differential Nonlinearity (DNL)	-1		+1	LSB	Measured at an output of the excitation loop, using gain = 1 and default DAC clock (16 MHz ÷ 49 DAC clock speed)
Full-Scale Error		±0.2		% FSR	PGA (gain = 1), measured at an output of the excitation loop, DAC code = 0xE00
		±1		% FSR	PGA (gain = 0.025), measured at an output of the excitation loop, DAC code = 0xE00
Negative		±0.2		% FSR	PGA (gain = 1), measured at an output of the excitation loop, DAC code = 0x200
		±1		% FSR	PGA (gain = 0.025), measured at an output of the excitation loop, DAC code = 0x200
Offset Error, Midscale		±1		mV	PGA (gain = 1 or gain = 0.025), measured at an output of the excitation loop across RCAL
Clocking Frequency	280.7	320	380.95	kHz	
PROGRAMMABLE GAIN AMPLIFIER (PGA)					
Gain from PGA in State 0		1			Covered by DAC full-scale error measured on an output of the excitation loop
Gain from PGA in State 1		0.025			Covered by DAC full-scale error measured on an output of the excitation loop
RECONSTRUCTION FILTER (RCF)					
3 dB Corner Frequency		50		kHz	

¹ There may be some system offsets and gain errors that can be calibrated at the system level to improve dc accuracy. Hence, the voltage swing at the output of the DAC is ±800 mV to guarantee ±600 mV swing on the sensor.

SWITCH MATRIX SPECIFICATIONS**Table 4. Switch Matrix Specifications**

Parameter	Min	Typ	Max	Unit	Test Conditions/Comments
R _{ON} ¹					
Current Carrying Switches					
Dx, DR1, Tx, and TR2		40	50	Ω	
IVS		40	75	Ω	
Noncurrent Carrying Switches					
Px, Nx, and NR2	600		900	Ω	
PR1	600		950	Ω	
NL	260		350	Ω	
PL	210		260	Ω	
DC OFF LEAKAGE ²					
T and N Switches		370		pA	Sum value of four T switches and four N switches
P Switches		340		pA	Sum value of four P switches
D Switches		350		pA	Sum value of four D switches

Parameter	Min	Typ	Max	Unit	Test Conditions/Comments
DC ON LEAKAGE ²					
T, N, and P Switches		530		pA	Sum value for 25 switches, including NL
D Switches		340		pA	Sum value for eight switches

¹ R_{ON} characterized with a voltage sweep from 0 V to V_{CCM}. Production tested at 1.8 V.

² See Figure 38 as a reference. The AFE x pin is driven to 0.2 V.

TRANSIMPEDANCE AMPLIFIER SPECIFICATIONS

Table 5. Transimpedance Amplifier Specifications

Parameter	Min	Typ	Max	Unit	Test Conditions/Comments
TRANSIMPEDANCE AMPLIFIER					
Maximum Current Sink/Source		±5		mA	Ensure an R _{TIA} selection to generate ±750 mV swing for optimal linearity performance
Short-Circuit Protection Functionality		10		mA	

ADC SPECIFICATIONS

Table 6. ADC Specifications¹

Parameter	Min	Typ	Max	Unit	Test Conditions/Comments
ADC					
Input Range	0.35		1.85	V	Internal reference
No Missing Codes		16		Bits	
DNL		±0.9		LSB	
INL		±0.7		LSB	@ 160 kSPS with respect to an optimal voltage range of ±750 mV, from 0°C to 50°C
		±1		LSB	@ 160 kSPS with respect to an optimal voltage range of ±750 mV, from -40°C to +85°C
Sample Rate After Decimation		160		kSPS	
3 dB Bandwidth		54		kHz	

¹ R_{TIA} = 7.5 kΩ, C_{TIA} = 220 pF; ±100 μA current measurement.

TEMPERATURE SENSOR SPECIFICATIONS

Table 7. Temperature Sensor Specifications

Parameter	Min	Typ	Max	Unit	Test Conditions/Comments
TEMPERATURE SENSOR					
Accuracy		±1		°C	0°C to 50°C, trimmed at 25°C
		±2		°C	-40°C to +85°C, trimmed at +25°C

CapTouch

Table 8. CapTouch Specifications

Parameter	Min	Typ	Max	Unit	Test Conditions/Comments
CapTouch™ CHARACTERISTICS					
Core Resolution		14		Bits	
Core SNR	60			dB	1 kHz test tone, input range of ADC = 1.8 V
CAPT_x		±10		nA	GPIO leakage test
Update Rate	7.5		1E6	μs	Programmable, dependent on configuration
Update Rate per Sensor	7.5			μs	No filtering enabled, clock = 16 MHz
CAPT_x Input Range		±8		pF	ΔC _{IN} is register programmable from 0.5 pF to 9.3 pF
CAPT_x Offset (CapDAC) Range		75		pF	

Parameter	Min	Typ	Max	Unit	Test Conditions/Comments
CapDAC Resolution		0.1		pF	
Output Noise					
Peak-to-Peak		8		Codes	
RMS		1.3		Codes	

DFT-BASED IMPEDANCE MEASUREMENTS

Table 9. DFT-Based Impedance Measurements¹

Parameter	Min	Typ	Max	Unit	Test Conditions/Comments
IMPEDANCE					
Accuracy ²					
Magnitude			0.33	%	Standard deviation as a percent of Z
Phase			0.17	Degrees	Standard deviation of Z
Precision ³					
Magnitude			0.17	%	Standard deviation as a percent of Z
Phase			0.08	Degrees	Standard deviation of Z

¹ For a Z of 181 Ω (0.02% tolerant resistor). Excitation frequency = 20 kHz, sine amplitude = 9 mV_{RMS}, R_{CAL} = 1 k Ω , R_{TIA} = 7.5 k Ω , C_{TIA} = 220 pF. Measurements at 25°C. Single DFT measurement.

² Device-to-device repeatability for 1000 devices.

³ Single device, repeatable measurements.

DIGITAL PLATFORM

Digital LDO

Table 10. Digital LDO Specifications

Parameter	Min	Typ	Max	Unit	Test Conditions/Comments
OUTPUT VOLTAGE	1.71	1.8	1.89	V	Measured with a C _{LOAD} = 0.47 μ F, measured with a 10 mA load current on DVDD
DROPOUT		150	200	mV	10 mA load applied, no AFE blocks enabled
REGULATION					
Line		1.4		mV/V	10 mA load current on DVDD
Load		0.41		mV/mA	0 mA to 10 mA load current
POWER-UP TIME		42		μ s	Time taken from LDO enable to when LDO voltage is within specification, C _{LOAD} = 0.47 μ F, regulator unloaded

Low Power LDO

Table 11. Low Power LDO Specifications

Parameter	Min	Typ	Max	Unit	Test Conditions/Comments
OUTPUT VOLTAGE	1.71	1.8	1.89	V	
REGULATION					
Line		0.45		mV/V	VCCM = 2.0 V to 3.6 V
Load		28.5		mV/mA	0 μ A to 100 μ A load

Flash/General-Purpose Flash**Table 12. Flash/General-Purpose Flash Specifications**

Parameter	Min	Typ	Max	Unit	Test Conditions/Comments
FLASH/GP FLASH					
Endurance ¹	20,000			Cycles	
Erase Time		20		ms	@ 1.8 V
Program Time		20		μs	@ 1.8 V
Data Retention ²		100		Years	Below room temperature

¹ Endurance is qualified to 10,000 cycles as per JEDEC Std. 22 Method A117 and measured at -40°C, +25°C, and +125°C. Typical endurance at 25°C is 170,000 cycles.

² Retention lifetime equivalent at junction temperature (T_j) = 85°C as per JEDEC Std. 22 Method A117. Retention lifetime derates with junction temperature.

Digital Inputs/Outputs: Specified

Specified pin supply range from 2.5 V to 3.6 V.

Table 13. Digital Inputs and Outputs¹ Specifications

Parameter	Min	Typ	Max	Unit	Test Conditions/Comments
PIN SUPPLY	2.5	3	3.6	V	
Impedance					
Pull-Down		20		kΩ	I _{SINK} < 10 μA
Pull-Up		15		kΩ	I _{SOURCE} < 10 μA
Internal Pull-Up/Pull-Down Enabled Leakage ²		200		μA	
Digital I/O Leakage Current		.01	1	μA	
Input Capacitance		10		pF	
Input Voltage					
Low (V _{INL})			0.3 × pin supply	V	
High (V _{INH})	0.7 × pin supply			V	
Output Voltage					
Low (V _{OL})			0.4	V	I _{SINK} = 1.0 mA
V _{OL} High Drive		0.4		V	I _{SINK} = 1.6 mA
High (V _{OH}) ³	Pin supply – 0.4			V	I _{SOURCE} = 1.0 mA
V _{OH} High Drive		2.4		V	I _{SOURCE} = 1.6 mA

¹ Includes GPIO, debug, SPI, I²C, PDI, LCD, I²S, and beeper.

² See Table 35 for details regarding bumps/pins that have pull-up resistors.

³ I²C does not drive out a high voltage; it uses external pull-up resistors.

Digital Inputs/Outputs: Functional

Functional pin supply range from 1.65 V to 2.5 V.

Table 14. Digital Inputs/Outputs: Functional Specifications

Parameter	Min	Typ	Max	Unit	Test Conditions/Comments
PIN SUPPLY	1.65		2.5	V	
Input Voltage					
Low (V _{INL})		0.3 × pin supply		V	
High (V _{INH})		0.7 × pin supply		V	
Output Voltage					
Low (V _{OL})		0.45		V	I _{SINK} = 1.0 mA
High (V _{OH}) ¹		Pin supply – 0.5		V	I _{SOURCE} = 1.0 mA

¹ I²C does not drive out a high voltage; it uses external pull-up resistors.

Universal Serial Bus Regulator Specifications**Table 15. Universal Serial Bus Regulator Specifications**

Parameter	Min	Typ	Max	Unit	Test Conditions/Comments
SERIAL BUS REGULATOR					
Input Voltage Range	3.6		5.25	V	40 mA continuous current 4.5 V to 5.5 V @ 5 V, 220 nF ceramic decoupling capacitor
Regulated Output Voltage	3.2		3.4	V	
Dropout		440		mV	
Regulation					
Line		0.0043		%/V	
Load		0.0093		%/mA	
Power-Up Time		37		μs	

Universal Serial Bus DC Specifications**Table 16. Universal Serial Bus DC Specifications**

Parameter	Min	Typ	Max	Unit	Test Conditions/Comments
RECEIVER					
Single-Ended Input Voltage (Driven)					V(USB DP) – V(USB DM)
High	2.0			V	
Low			0.8	V	
Differential Receiver Input					
Common Mode	0.8		2.5	V	
Sensitivity	0.2			V	
TRANSMITTER					
Output Voltage					Pull-up resistor asserted on the USB pin, USB DP, R _{PU} to AVDD Pull-down resistor asserted on USB DP and USB DM (15 kΩ to GND) R _{DRIVER} + R _{SERIES} Termination voltage = USB regulator voltage Termination voltage = USB regulator voltage
Low (V _{OL})	0		0.3	V	
High (V _{OH})	2.8		3.6	V	
Driver Output Impedance	28		44	Ω	
Term Series Resistor		40		Ω	
Pull-Up Resistor (D+ High)	1.425	1.5	3.095	kΩ	
Pull-Up Resistor (D+ Low)	0.9		1.575	kΩ	
Pull-Down Resistors	14.25	15	24.8	kΩ	

Universal Serial Bus AC Specifications

Meeting USB 2.0 compliance electrical tests.

Table 17. Universal Serial Bus AC Specifications

Parameter	Min	Typ	Max	Unit	Test Conditions/Comments
FULL SPEED DRIVER TIMING					
Signaling Rate	11.988	12		MHz	C _{LOAD} = 50 pF
Output Time					
Rise	4		20	ns	V _{OH} – V _{OL} (10% to 90%), C _{LOAD} = 50 pF
Fall	4		20	ns	V _{OH} – V _{OL} (10% to 90%), C _{LOAD} = 50 pF
Rise and Fall Matching	90		111.1	%	Exclude transition from idle
Output Voltage Crossover	1.3		2.0	V	Exclude transition from idle
FULL SPEED JITTER					
Driver Jitter Generated	–2		+2	ns	C _{LOAD} = 50 pF Next transitions
	–1		+1	ns	Paired transitions
Load Capacitance			50	pF	Testing slew rate

LCD, Charge Pump**Table 18. LCD, Charge Pump Specifications**

Parameter	Min	Typ	Max	Unit	Test Conditions/Comments
CAPACITANCE					
Reservoir Capacitance Between VLCDVDD and VLCD_GND	0.47	1		μF	
Flying Capacitance	2.2		4.7	nF	Between VLCD FLY1 and VLCD FLY2
VLCD					
Switching Voltage					
VLCD FLY1	-0.7		VLCD + 0.2	V	Top of flying capacitor
VLCD FLY2	0		VCCM	V	Bottom of flying capacitor
VLCD Charge Pump Switching Frequency		32		kHz	
Minimum VLCD with Respect to VCCM_ANA and VCCM_DIG	2.1			V	When <2.1 V after 62.5 ms elapses indicates fault condition
VLCDVDD					
VLCDVDD Voltage Range	2.4		3.65	V	5-bit programmable in steps of 40 mV
VLCDVDD Pin Leakage		3		nA	To VCCM
		0.2		nA	To GND
VLCDVDD Start-Up Time		5		ms	VLCDVDD = 0 V to 3.6 V, reservoir = 1 μF, flying capacitor = 2.2 nF (minimum) and 4.7 nF (maximum)
VLCDVDD Line Regulation		0.32		%	
V_LCD_xx VOLTAGE RANGE					
V_LCD_13 Voltage Range	VLCD ÷ 3 – 10		VLCD ÷ 3 + 10	mV	
V_LCD_23 Voltage Range	2/3 VLCD – 13		2/3 VLCD + 13	mV	
COMx PINS					
DC Voltage Across Segment and COMx Pins			50	mV	
PIN OUTPUT IMPEDANCE					
Segment		2000		Ω	
Common		130		Ω	

SYSTEM CLOCKS/TIMERS

The following tables document the system clock specifications in the [ADuCM350](#).

Platform External Crystal Oscillator**Table 19. Platform External Crystal Oscillator Specifications**

Parameter	Min	Typ	Max	Unit	Test Conditions/Comments
LOW FREQUENCY					
C _{EXT1} = C _{EXT2}	12	15	18	pF	External capacitor, C1 = C2 (symmetrical load)
Frequency		32,768		Hz	
HIGH FREQUENCY					
C _{EXT1} = C _{EXT2}	10	12	15	pF	External capacitor
Frequency		8 or 16		MHz	

On-Chip RC Oscillators**Table 20. On-Chip RC Oscillators Specifications**

Parameter	Min	Typ	Max	Unit	Test Conditions/Comments
HIGH FREQUENCY RC OSCILLATOR					
Frequency		16		MHz	
Accuracy	-5		+5	%	
Start-Up Time		35		μs	
LOW FREQUENCY RC OSCILLATOR					
Frequency		32,768		Hz	
Accuracy	-20		+20	%	
Start-Up Time		980		μs	

PLLs**Table 21. PLL Specifications**

Parameter	Min	Typ	Max	Unit	Test Conditions/Comments
SYSTEM PLL					
Input Frequency	8	16		MHz	
Output Frequency		16	32	MHz	
Frequency Error			2500	ppm	
RMS Jitter			92	ps	@ 32 MHz, external XTAL
USB PLL					
Input Frequency	8	16		MHz	
Output Frequency	16		60	MHz	16 MHz input
Frequency Error			2500	ppm	
Period Jitter			68	ps	@ 60 MHz, external XTAL

Watchdog, Wake-Up, and General-Purpose Timers**Table 22. Watchdog, Wake-Up, and General-Purpose Timers Specifications**

Parameter ¹	Min	Typ	Max	Unit	Test Conditions/Comments
WATCHDOG TIMERS					
Timeout Period					
Shortest		0.03		ms	32,768 Hz clock, prescaler = 1
Longest		8191		sec	32,768 Hz clock, prescaler = 4096
WAKE-UP TIMERS					
Timeout Period					
Shortest		62.5		ns	16 MHz clock, prescaler = 1
Longest		136		Years	32,768 Hz clock, prescaler = 32,768
GENERAL-PURPOSE TIMER × 3					
Timeout Period					
Shortest		62.5		ns	16 MHz clock, prescaler = 1
Longest		65,535		sec	32,768 Hz clock, prescaler = 32,768
Timer Output PWM Frequency	1		16	MHz	

¹ Guaranteed by design.

POWER MANAGEMENT SPECIFICATIONS

The following tables cover the specifications for the power management section of the [ADuCM350](#).

Power Supplies**Table 23. Power Supplies Specifications**

Parameter	Min	Typ	Max	Unit	Test Conditions/Comments
SUPPLIES					
VCCM_ANA/VCCM_DIG	2		3.6	V	VCCM_x pins connected to the CR2032 battery, main supply for ADuCM350
VCCM_ANA/VCCM_DIG	2.5		3.6	V	Battery operating range
VBACK	1.62		3.6	V	Super capacitor pin, back-up mode supply
VBUS	4.75	5	5.25	V	USB 5 V supply
VDD_IO	1.8		3.6	V	Supply for some digital I/O pads; see Table 35, I/O supply column for details
VLCDVDD	1.8		3.6	V	Supply for LCD I/O

Power Supply Monitoring**Table 24. Power Supply Monitoring Specifications**

Parameter ¹	Min	Typ	Max	Unit	Test Conditions/Comments
VCCM PSM					
Voltage Detection Range			1.7		100 mV step size
Hysteresis			±10	mV	
Trip Point Detection Accuracy				mV	Hysteresis + 70
VRTC PSM					
Voltage Detection Range			1.55		100 mV step size
Hysteresis			±25	mV	
Trip Point Detection Accuracy				mV	Hysteresis + 70
VBACK PSM					
Voltage Detection Range			1.7		100 mV step size
Hysteresis				mV	±100
Trip Point Detection Accuracy				mV	Hysteresis + 70

¹ For details regarding these parameters, see the [UG-587](#) hardware reference manual.

TRICKLE CHARGER**Table 25. Trickle Charger Specifications**

Parameter	Min	Typ	Max	Unit	Test Conditions/Comments
CURRENT					
Charge Current		0.48		mA	Limits load on button cell at power-up
Reverse Current			1	μA	
VOLTAGE					
Forward Voltage		40	120	mV	Where forward current reduces to zero

TIMING CHARACTERISTICS**LCD Segment/Common Timing Specifications**Table 26. LCD Segment/Common Timing Specifications^{1,2}

FRAMESEL[3]	FRAMESEL[2]	FRAMESEL[1]	FRAMESEL[0]	Static Mux		4× Mux	
				f _{LCD} (Hz)	Frame Rate (Hz)	f _{LCD} (Hz)	Frame Rate (Hz)
0	0	0	0	256	128	1024	128
0	0	0	1	204.8	102.4	819.2	102.4
0	0	1	0	170.7	85.3	682.7	85.3
0	0	1	1	146.3	73.1	585.1	73.1
0	1	0	0	128	64	512	64
0	1	0	1	113.8	56.9	455.1	56.9
0	1	1	0	102.4	51.2	409.6	51.2
0	1	1	1	93.1	46.5	372.4	46.5
1	0	0	0	85.3	42.7	341.3	42.7
1	0	0	1	78.8	39.4	315.1	39.4
1	0	1	0	73.1	36.6	292.6	36.6
1	0	1	1	68.3	34.1	273.1	34.1
1	1	0	0	64	32	256	32
1	1	0	1	60.2	30.1	240.9	30.1
1	1	1	0	56.9	28.4	227.6	28.4
1	1	1	1	53.9	26.9	215.6	26.9

¹ f_{LCD} = f_{BCLK} / (FRAMESEL + 4). See the [UG-587](#) hardware reference manual for details

² FRAMESEL[3], FRAMESEL[2], FRAMESEL[1], and FRAMESEL[0] indicate the bit numbers in the LCD_COM register.

I²C Timing

Capacitive load for each of the I²C bus lines (C_B) = 400 pF maximum as per I²C bus specifications; I²C timing is guaranteed by design and not production tested.

Table 27. I²C Timing in Fast Mode (400 kHz)

Parameter	Description	Min	Max	Unit
t _L	Clock low pulse width	1300		ns
t _H	Clock high pulse width	600		ns
t _{SHD}	Start condition hold time	600		ns
t _{DSU}	Data setup time	100		ns
t _{DHD} ¹	Data hold time	0		ns
t _{RSU}	Setup time for repeated start	600		ns
t _{PSU}	Stop condition setup time	600		ns
t _{BUF}	Bus-free time between a stop condition and a start condition	1.3		μs
t _R	Rise time for both clock and data	20 + 0.1 C _B	300	ns
t _F	Fall time for both clock and data	20 + 0.1 C _B	300	ns
t _{SUP}	Pulse width of spike suppressed	0	50	ns

¹ A device must internally provide a hold time of at least 300 ns for the SDA signal (with respect to the V_{NH} (minimum) of the SCL signal) to bridge the undefined region of the falling edge of SCL.

Table 28. I²C Timing in Standard Mode (100 kHz)

Parameter	Description	Min	Max	Unit
t _L	Clock low pulse width	4.7		μs
t _H	Clock high pulse width	4.0		ns
t _{SHD}	Start condition hold time	4.7		μs
t _{DSU}	Data setup time	250		ns
t _{DHD} ¹	Data hold time	0		μs
t _{RSU}	Setup time for repeated start	4.0		μs

Parameter	Description	Min	Max	Unit
t_{PSU}	Stop condition setup time	4.0		μ s
t_{BUF}	Bus-free time between a stop condition and a start condition	4.7		μ s
t_R	Rise time for both clock and data		1	μ s
t_F	Fall time for both clock and data		300	ns

¹ A device must internally provide a hold time of at least 300 ns for the SDA signal (with respect to the V_{INH} (minimum) of the SCL signal) to bridge the undefined region of the falling edge of SCL.

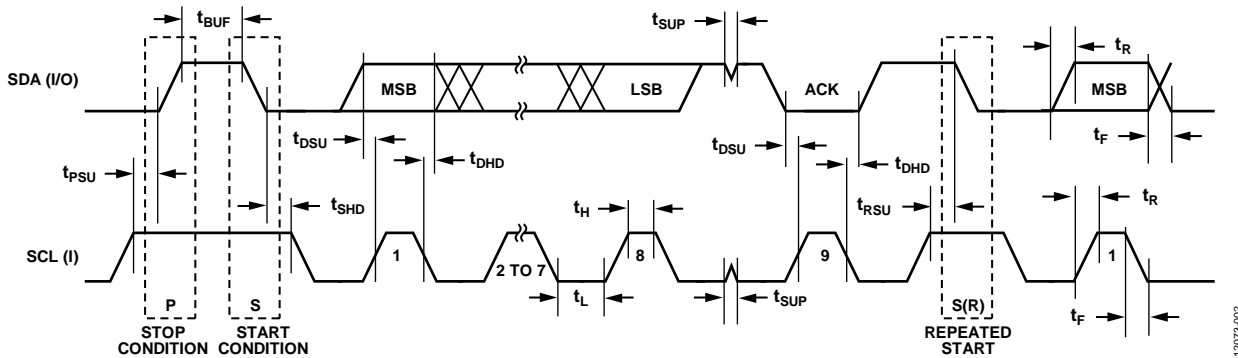

Figure 2. I²C-Compatible Interface Timing

12073-002

I²S Timing Specifications

I²S timing is guaranteed by design and not production tested; timing specifications are given for a standard I²S data rate of 2.5 MHz; the I²S bus is designed to operate up to 25 MHz.

Table 29. I²S Timing: Master Transmitter

Parameter	Symbol	Min	Typ	Max	Unit	Test Conditions/Comments ¹
I²S MASTER TRANSMITTER TIMING						
SCLK Period	T	360	400	440	ns	
Minimum Clock Period	T _{TR}	360			ns	T _{TR} is the minimum allowed clock period for the transmitter, T > T _{TR}
Clock High Period	t _{HC}	160			ns	Minimum > 0.35 × T = 140 ns
Clock Low Period	t _{LC}	160			ns	Minimum > 0.35 × T = 140 ns
Delay	t _{DTR}			300	ns	Minimum < 0.80 × T = 320 ns
Data Hold Time	t _{HTR}	100			ns	Minimum > 0 ns
Clock Rise Time	t _{RC}			60	ns	Minimum > 0.15 × T _{TR} = 54 ns (slave mode only)

¹ T refers to the typical value listed for the SCLK period; therefore, T = 400 ns in this case.

Table 30. I²S Timing: Slave Receiver

Parameter	Symbol	Min	Typ	Max	Unit	Test Conditions/Comments ¹
I²S SLAVE RECEIVER TIMING						
SCLK Period	T	360	400	440	ns	T _{TR} = 360 ns
Clock High Period	t _{HC}	110			ns	Minimum < 0.35 × T = 126 ns
Clock Low Period	t _{LC}	160			ns	Minimum < 0.35 × T = 126 ns
Data Setup Time	t _{SR}			300	ns	Minimum < 0.20 × T = 72 ns
Data Hold Time	t _{HTR}	100			ns	Minimum < 0 ns

¹ T refers to the typical value listed for the SCLK period; therefore, T = 400 ns in this case.

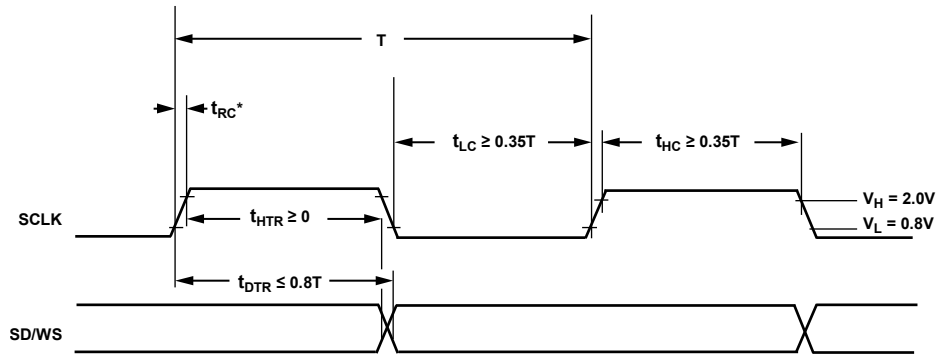

*t_{RC} IS ONLY RELEVANT FOR TRANSMITTERS IN SLAVE MODE.

NOTES

- SD = SERIAL DATA, WS = WORD SELECT, WS = 0: CHANNEL 1 (LEFT), WS = 1: CHANNEL 2 (RIGHT).

Figure 3. I²S-Compatible Interface Transmitter Timing

12073-003

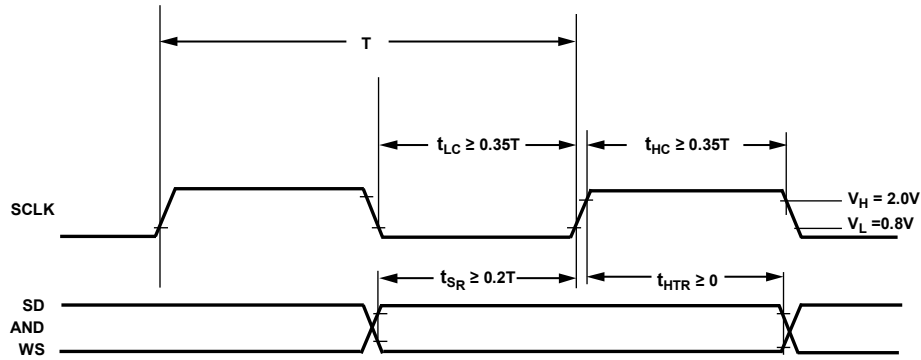

NOTES
1. SD = SERIAL DATA, WS = WORD SELECT, WS = 0: CHANNEL 1 (LEFT), WS = 1: CHANNEL 2 (RIGHT).

Figure 4. I²S-Compatible Interface Receiver Timing

SPI Timing

SPIH can be used for high data rate peripherals.

Table 31. SPI Master Mode Timing¹

Parameter	Description	Min	Typ	Max	Unit
t _{SL}	SCLK low pulse width ²		(SPIXDIV[5:0] + 1) × t _{UCLK}		ns
t _{SH}	SCLK high pulse width ²		(SPIXDIV[5:0] + 1) × t _{UCLK}		ns
t _{DAV}	Data output valid after SCLK edge		0	35.5	ns
t _{DOSU}	Data output setup before SCLK edge ²	(SPIDIV + 1) × t _{UCLK}			ns
t _{DSU}	Data input setup time before SCLK edge	58.7			ns
t _{DHD}	Data input hold time after SCLK edge	16			ns
t _{DF}	Data output fall time		12	35.5	ns
t _{DR}	Data output rise time		12	35.5	ns
t _{SR}	SCLK rise time		12	35.5	ns
t _{SF}	SCLK fall time		12	35.5	ns

¹ Guaranteed by design.

² t_{UCLK} = 62.5 ns. It corresponds to the maximum internal clock frequency before clock dividers.

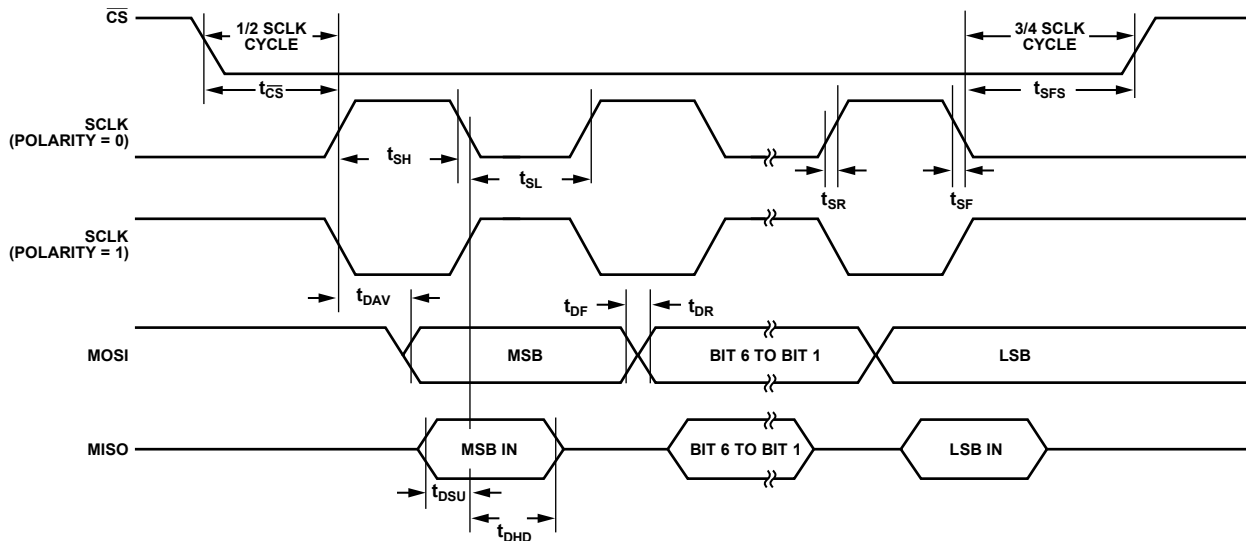

Figure 5. SPI Master Mode Timing (Phase Mode = 1)

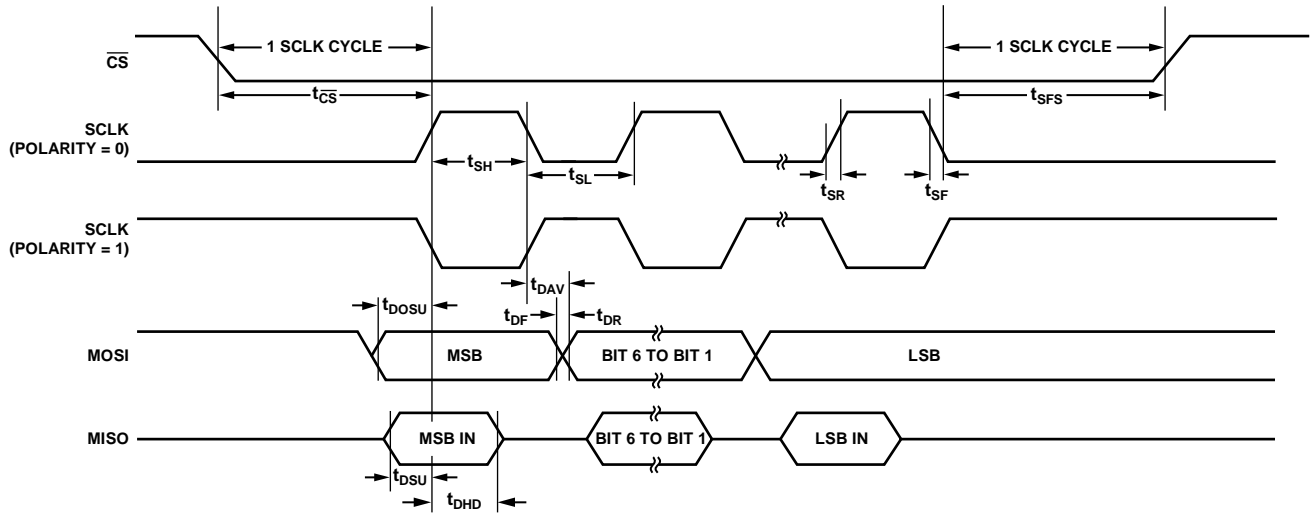

Figure 6. SPI Master Mode Timing (Phase Mode = 0)

12073-006

Table 32. SPI Slave Mode Timing

Parameter	Description	Min	Typ	Max	Unit
$t_{\overline{CS}}$	\overline{CS} to SCLK edge	38			ns
t_{SL}	SCLK low pulse width ¹		$(SPIXDIV[5:0] + 1) \times t_{UCLK}$		ns
t_{SH}	SCLK high pulse width ¹	62.5	$(SPIDIV[5:0] + 1) \times t_{UCLK}$		ns
t_{DAV}	Data output valid after SCLK edge			49.1	ns
t_{DSU}	Data input setup time before SCLK edge	20.2			ns
t_{DHD}	Data input hold time after SCLK edge	10.1			ns
t_{DF}	Data output fall time		12	35.5	ns
t_{DR}	Data output rise time		12	35.5	ns
t_{SR}	SCLK rise time		12	35.5	ns
t_{SF}	SCLK fall time		12	35.5	ns
t_{DOCS}	Data output valid after \overline{CS} edge			25	ns
t_{SFS}	\overline{CS} high after SCLK edge	0			ns

¹ $t_{UCLK} = 62.5$ ns. It corresponds to the maximum internal clock frequency before clock dividers.

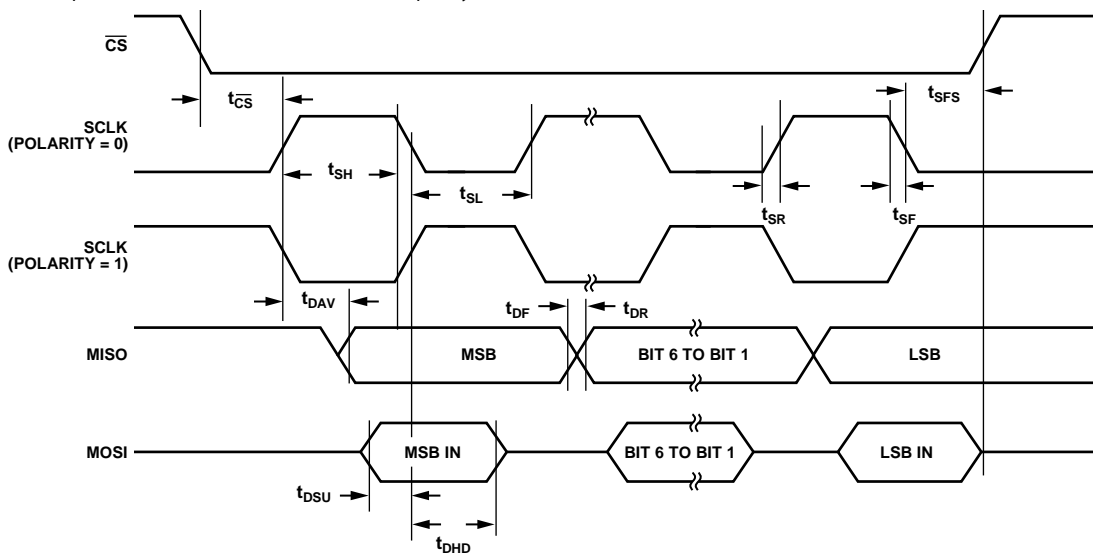

Figure 7. SPI Slave Mode Timing (Phase Mode = 1)

12073-007

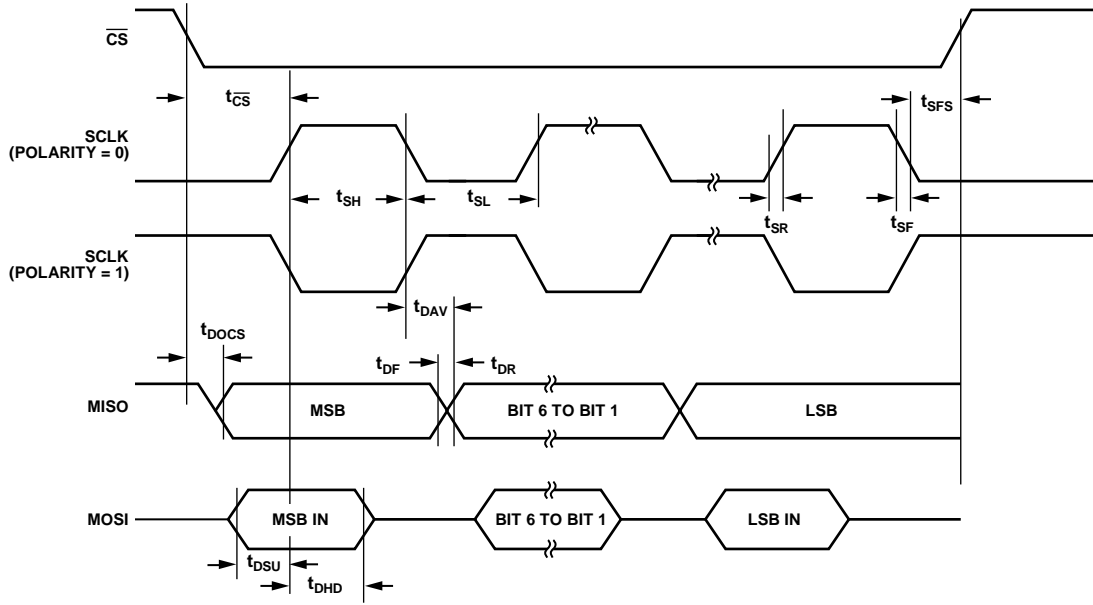

Figure 8. SPI Slave Mode Timing (Phase Mode = 0)

12073-008

ABSOLUTE MAXIMUM RATINGS

$T_A = 25^\circ\text{C}$, unless otherwise noted.

Table 33.

Parameter	Rating
Supplies	
VCCM_ANA, VCCM_DIG, VLCDVDD, VDD_IO, VBACK to AGND_x/DGNDx	-0.3 V to +3.6 V
Decoupling	
DVDD, AVDD_RX/TX, VBIAS, VREF, VUSB	-0.3 V to +2.0 V
Digital Input/Output	
P0.x, P1.x, P2.x, P3.x, P4.x, BOOT, RESETX	-0.3 V to +3.6 V
TRACEx	-0.3 V to +3.6 V
Switch Matrix (RCAL 1, RCAL 2, AFE x)	-0.3 V to +3.6 V
TIA (TIA_I, TIA_O)	-0.3 V to +3.6 V
Analog Inputs (AN_x)	-0.3 V to +3.6 V
REF_EXCITE	-0.3 V to +1.98 V
VLCD FLY1, VLCD FLY2	-0.3 V to +3.6 V
V_LCD_13, V_LCD_23	-0.3 V to +3.6 V
VBUS to DGND	-0.3 V to +5.25 V
USB DM, USB DP to DGND	-0.3 V to +3.6 V
HF_XTALx, LF_XTALx	-0.3 V to +1.98 V
Analog Ground to Digital Ground	
AGND CTOUCH, AGND_RX/TX, AGND_REF to DGND, DGND1, DGND2, DGND USB	-0.3 V to +0.3 V

Stresses at or above those listed under Absolute Maximum Ratings may cause permanent damage to the product. This is a stress rating only; functional operation of the product at these or any other conditions above those indicated in the operational section of this specification is not implied. Operation beyond the maximum operating conditions for extended periods may affect product reliability.

THERMAL RESISTANCE

θ_{JA} is specified for the worst-case conditions, that is, a device soldered in a circuit board for surface-mount packages; assumes use of a JEDEC 4-layer board.

Table 34. Thermal Resistance

Package Type	θ_{JA}	Unit
CSP_BGA	35	$^\circ\text{C}/\text{W}$

ESD CAUTION

ESD (electrostatic discharge) sensitive device. Charged devices and circuit boards can discharge without detection. Although this product features patented or proprietary protection circuitry, damage may occur on devices subjected to high energy ESD. Therefore, proper ESD precautions should be taken to avoid performance degradation or loss of functionality.

PIN CONFIGURATION AND FUNCTION DESCRIPTIONS

	1	2	3	4	5	6	7	8	9	10	11	12	13	14	15	
A	DNC	P2.1/ COM1/ RESX	P2.3/ COM3/ DCX	P2.5/S2/ ECLOCK- WRX	P1.0/S3/ D0/SCL	P1.2/S5/ D2/DIN	P1.4/S7/ D4	P1.6/S9/ D6	P1.8/S11/ D8	P1.10/ S13/D10	P1.12/ S15/D12	P1.14/ S17/D14	P2.10/S23	P2.9/S22	P2.15/S28	
B	V_LCD_23	P2.0/ COM0	P2.2/ COM2/ CSX	P2.4/S1/ RWX-RDX	P1.1/S4/ D1/DOOUT	P1.3/S6/ D3	P1.5/S8/ D5	P1.7/S10/ D7	P1.9/S12/ D9	P1.11/ S14/D11	P1.13/ S16/D13	P1.15/ S18/D15	P2.11/S24	P2.12/S25	P2.8/S21	
C	HF_XTAL2	V_LCD_13												P3.10/S31	P2.7/S20/ TOUTA	
D	HF_XTAL1	VLCDVDD												P2.13/S26	P2.6/ S19/TE	
E	VUSB	VLCD FLY1												P3.11/S32	P2.14/S27	
F	USB DM	VLCD FLY2				DGND USB	DGND2/ LCD_GND	P3.8/S29	P3.9/S30	P3.3/ SPI0_CS				P3.0/ SPI0_SCLK	P3.2/ SPI0_MOSI	
G	USB DP	VBUS				DGND1				P3.4/ I2CSCL/ SPI1_SCLK				P3.1/ SPI0_MISO	P3.6/UTX/ TOUTB/ SPI1_MOSI	
H	TMS- SWDIO/ P0.8	TCK- SWCLK/ P0.9				VCCM_ DIG				P3.5/ I2CSD/ SPI1_MISO				DGND	VDD_IO	
J	TDO-SWO/ P0.6/UTX	TDI/P0.7/ URX				P3.14/ LRCLK				P3.7/URX/ TOUTC/ SPI1_CS				P0.4/ CAPT_E	P0.1/ CAPT_B	
K	DVDD	P0.11				P3.12/ BEEP/ BMCLK	P3.13/ BEEPX/ SDATA	RESETX	AGND_RX/ AGND_TX	AGND_REF					P0.3/ CAPT_D	P0.0/ CAPT_A
L	P4.0/ I2CSCL	P4.1/ I2CSD													P0.5/ CAPT_F	P0.2/ CAPT_C
M	VBACK	P0.15/ SPIH_CS													TRACE0	TRACECLK
N	LF_XTAL2	BOOT													TRACE2	TRACE1
P	LF_XTAL1	P0.13/ SPIH_MISO	P0.14/ SPIH_MOSI	VCCM_ ANA	RCAL 1	AFE 2	AFE 4	AFE 6	AFE 8	VBIAS	TIA_I	AN_A	AN_B	AGND CTOUCH	TRACE3	
R	P4.2/ TOUTB	P0.10/ TOUTC	P0.12/ SPIH_SCLK	AVDD_RX/ AVDD_TX	RCAL 2	AFE 1	AFE 3	AFE 5	AFE 7	VREF	TIA_O	REF EXCITE	AN_C	AN_D	TRST	

Figure 9. Bump Location (Top View Looking Through Device, Bumps Not to Scale)

12073-009

Table 35. Pin Function Descriptions

Pin No.	Mnemonic	I/O ¹	I/O Supply ²	GPIO Pull-Up/Down ²	Description
Power and Ground					
P4	VCCM_ANA	S	VCCM_ANA	N/A	Battery Connection and Analog Circuit Power. Connect VCCM_ANA to the CR2032 battery. VCCM_ANA powers the analog circuits. This pin is connected to VCCM_DIG internally.
H6	VCCM_DIG	S	VCCM_DIG	N/A	Battery Connection and Digital Circuit Power. Connect VCCM_DIG to the CR2032 battery. VCCM_DIG powers the digital circuits. This pin is connected to VCCM_ANA internally.
G2	VBUS	S	VBUS	N/A	5 V USB Supply Voltage.
M1	VBACK	S	VBACK	N/A	RTC Supply. Connect VBACK to the super capacitor.
H15	VDD_IO	S	VDD_IO	N/A	VDD_IO Supply.
E1	VUSB	A	VUSB	N/A	Regulated USB 3.6 V Supply.
R10	VREF	A	N/A	N/A	1.8 V Reference Voltage Decoupling Capacitor Pin.
P10	VBIAS	A	N/A	N/A	1.1 V Bias Voltage Decoupling Capacitor Pin.

Pin No.	Mnemonic	I/O ¹	I/O Supply ²	GPIO Pull-Up/Down ²	Description
K1	DVDD	A	N/A	N/A	1.8V Digital Regulator Decoupling Capacitor Pin.
R4	AVDD_RX/AVDD_TX	A	AVDD TX/RX	N/A	1.8V Analog Regulator Decoupling Capacitor Pin for Receiver (Rx)/Transmitter (Tx) Circuits.
K9	AGND_RX/AGND_TX	G	N/A	N/A	Rx/Tx Analog Ground.
K10	AGND_REF	G	N/A	N/A	Reference Ground.
H14	DGND	G	N/A	N/A	Digital Ground.
G6	DGND1	G	N/A	N/A	Digital Ground.
F7	DGND2/LCD_GND	G	N/A	N/A	Digital Ground/Ground for LCD.
F6	DGND USB	G	N/A	N/A	USB Ground. Connect DGND USB to the digital ground plane.
AFE Pins					
P12	AN_A	A	VCCM_ANA	N/A	ADC Mux Input.
P13	AN_B	A	VCCM_ANA	N/A	ADC Mux Input.
R13	AN_C	A	VCCM_ANA	N/A	ADC Mux Input.
R14	AN_D	A	VCCM_ANA	N/A	ADC Mux Input.
P5	RCAL 1	A	VCCM_ANA	N/A	Terminal A of Calibration Resistor. Connect RCAL 1 to the switch matrix.
R5	RCAL 2	A	VCCM_ANA	N/A	Terminal B of Calibration Resistor. Connect RCAL 2 to the switch matrix.
R6	AFE 1	A	VCCM_ANA	N/A	Uncommitted AFE Pin 1.
P6	AFE 2	A	VCCM_ANA	N/A	Uncommitted AFE Pin 2.
R7	AFE 3	A	VCCM_ANA	N/A	Uncommitted AFE Pin 3.
P7	AFE 4	A	VCCM_ANA	N/A	Uncommitted AFE Pin 4.
R8	AFE 5	A	VCCM_ANA	N/A	Uncommitted AFE Pin 5.
P8	AFE 6	A	VCCM_ANA	N/A	Uncommitted AFE Pin 6.
R9	AFE 7	A	VCCM_ANA	N/A	Uncommitted AFE Pin 7.
P9	AFE 8	A	VCCM_ANA	N/A	Uncommitted AFE Pin 8.
P11	TIA_I	A	VCCM_ANA	N/A	Transimpedance Amplifier Input. Connect the IV resistor to this pin.
R11	TIA_O	A	VCCM_ANA	N/A	Transimpedance Amplifier Output. Connect the IV resistor to this pin.
R12	REF_EXCITE	A	VCCM_ANA	N/A	Gated Precision Reference Voltage.
Debug Interface					
J1	TDO-SWO/P0.6/UTX	I/O	VCCM_DIG	Pull-up	JTAG Serial Data Output or Serial Wire Trace Output/GPIO/UART_TX. This is a multifunction pin.
J2	TDI/P0.7/URX	I/O	VCCM_DIG	Pull-up	JTAG Serial Data Input/GPIO/UART_RX. This is a multifunction pin.
H1	TMS-SWDIO/P0.8	I/O	VCCM_DIG	Pull-up	JTAG Test Mode Select or Serial Wire Data/GPIO. This is a multifunction pin.
H2	TCK-SWCLK/P0.9	I/O	VCCM_DIG	Pull-down	JTAG Test Clock or Serial Wire Clock/GPIO. This is a multifunction pin.
R15	TRST	I	VCCM	N/A	Trace Reset.
M15	TRACECLK	O	VCCM	N/A	Trace Clock.
M14	TRACE0	O	VCCM	N/A	Trace Data 0.
N15	TRACE1	O	VCCM	N/A	Trace Data 1.
N14	TRACE2	O	VCCM	N/A	Trace Data 2.
P15	TRACE3	O	VCCM	N/A	Trace Data 3.

Pin No.	Mnemonic	I/O ¹	I/O Supply ²	GPIO Pull-Up/Down ²	Description
SPI H					
R3	P0.12/SPIH_SCLK	I/O	VCCM_DIG	Pull-up	GPIO/Serial Port H Clock. This is a dual function pin.
P2	P0.13/SPIH_MISO	I/O	VCCM_DIG	Pull-up	GPIO/Serial Port H MISO. This is a dual function pin.
P3	P0.14/SPIH_MOSI	I/O	VCCM_DIG	Pull-up	GPIO/Serial Port H MOSI. This is a dual function pin.
M2	P0.15/SPIH_CS	I/O	VCCM_DIG	Pull-up	GPIO/Serial Port H Chip Select (Active Low). This is a dual function pin.
Other Serial Ports					
F14	P3.0/SPI0_SCLK	I/O	VDD_IO	Pull-up	GPIO/SPI 0 SCLK. This is a dual function pin.
G14	P3.1/SPI0_MISO	I/O	VDD_IO	Pull-up	GPIO/SPI 0 MISO. This is a dual function pin.
F15	P3.2/SPI0_MOSI	I/O	VDD_IO	Pull-up	GPIO/SPI 0 MOSI. This is a dual function pin.
F10	P3.3/SPI0_CS	I/O	VDD_IO	Pull-up	GPIO/SPI 0 Chip Select (Active Low). This is a dual function pin.
G10	P3.4/I2CSCL/SPI1_SCLK	I/O	VDD_IO	Pull-up	GPIO (External Interrupt 7)/I ² C Clock/SPI 1 SCLK. This is a multifunction pin.
H10	P3.5/I2CSD/SPI1_MISO	I/O	VDD_IO	Pull-up	GPIO/I2C Data/SPI 1 MISO. This is a multifunction pin.
G15	P3.6/UTX/TOUTB/SPI1_MOSI	I/O	VDD_IO	Pull-up	GPIO/UART Tx/Timer B Output/SPI 1 MOSI. This is a multifunction pin.
J10	P3.7/URX/TOUTC/SPI1_CS	I/O	VDD_IO	Pull-up	GPIO/UART Rx/Timer C Output/SPI 1 Chip Select (Active Low). This is a multifunction pin.
USB					
F1	USB DM	I/O	VCCM_DIG	N/A	USB Data –.
G1	USB DP	I/O	VCCM_DIG	N/A	USB Data +.
CapTouch Interface					
K15	P0.0/CAPT_A	A	VCCM_DIG	Pull-up	GPIO (External Interrupt 1)/CapTouch A. This is a dual function pin.
J15	P0.1/CAPT_B	A	VCCM_DIG	Pull-up	GPIO (External Interrupt 2)/CapTouch B. This is a dual function pin.
L15	P0.2/CAPT_C	A	VCCM_DIG	Pull-up	GPIO (External Interrupt 3)/CapTouch C. This is a dual function pin.
K14	P0.3/CAPT_D	A	VCCM_DIG	Pull-up	GPIO (External Interrupt 4)/CapTouch D. This is a dual function pin.
J14	P0.4/CAPT_E	A	VCCM_DIG	Pull-up	GPIO (External Interrupt 5)/CapTouch E. This is a dual function pin.
L14	P0.5/CAPT_F	A	VCCM_DIG	Pull-up	GPIO (External Interrupt 6)/CapTouch F. This is a dual function pin.
P14	AGND CTOUCH	G	N/A	N/A	Capacitance to Digital Converter AC Shield.
System Clocks					
P1	LF_XTAL1	A	RTC_VBACK	N/A	32 kHz XTAL Pin.
N1	LF_XTAL2	A	RTC_VBACK	N/A	32 kHz XTAL Pin.
D1	HF_XTAL1	A	DVDD	N/A	16 MHz XTAL Pin.
C1	HF_XTAL2	A	DVDD	N/A	16 MHz XTAL Pin.
Display					
E2	VLCD FLY1	A	VLCD VDD	N/A	LCD Flying Capacitor Top Plate.
F2	VLCD FLY2	A	VLCD VDD	N/A	LCD Flying Capacitor Bottom Plate.
D2	VLCDVDD	S	N/A	N/A	Full-Scale LCD Voltage Output or VLCD Supply.
C2	V_LCD_13	A	VLCD VDD	N/A	One-Third (1/3) LCD Voltage. Leave this pin as no connect.
B1	V_LCD_23	A	VLCD VDD	N/A	Two-Thirds (2/3) LCD Voltage. Leave this pin as no connect.

Pin No.	Mnemonic	I/O ¹	I/O Supply ²	GPIO Pull-Up/Down ²	Description
B2	P2.0/COM0	I/O	VLCD VDD	Pull-up	GPIO/Common Output 0 for LCD Back Plane (COM 0). This is a dual function pin.
A2	P2.1/COM1/RESX	I/O	VLCD VDD	Pull-up	GPIO/COM 1/Parallel Display Interface (PDI) Reset. This is a multifunction pin.
B3	P2.2/COM2/CSX	I/O	VLCD VDD	Pull-up	GPIO/COM 2/PDI Chip Select. This is a multifunction pin.
A3	P2.3/COM3/DCX	I/O	VLCD VDD	Pull-up	GPIO/COM 3/PDI Data Select. This is a multifunction pin.
B4	P2.4/S1/RWX-RDX	I/O	VLCD VDD	Pull-up	GPIO/Segment Driver 1 (SEG 1)/PDI R/WX or RDX. This is a multifunction pin.
A4	P2.5/S2/ECLOCK-WRX	I/O	VLCD VDD	Pull-up	GPIO/SEG 2/PDI E Clock Output (Motorola Bus Mode) or PD Write Select (Intel® Bus Mode). This is a multifunction pin.
A5	P1.0/S3/D0/SCL	I/O	VLCD VDD	Pull-down	GPIO/SEG 3/PDI D0/PDI Serial Port Clock. This is a multifunction pin.
B5	P1.1/S4/D1/DOUT	I/O	VLCD VDD	Pull-down	GPIO/SEG 4/PDI D1/PDI Serial Port Data Output. This is a multifunction pin.
A6	P1.2/S5/D2/DIN	I/O	VLCD VDD	Pull-down	GPIO/SEG 5/PDI D2/PDI Serial Port Data Input. This is a multifunction pin.
B6	P1.3/S6/D3	I/O	VLCD VDD	Pull-down	GPIO/SEG 6/PDI D3. This is a multifunction pin.
A7	P1.4/S7/D4	I/O	VLCD VDD	Pull-down	GPIO/SEG 7/PDI D4. This is a multifunction pin.
B7	P1.5/S8/D5	I/O	VLCD VDD	Pull-down	GPIO/SEG 8/PDI D5. This is a multifunction pin.
A8	P1.6/S9/D6	I/O	VLCD VDD	Pull-down	GPIO/SEG 9/PDI D6. This is a multifunction pin.
B8	P1.7/S10/D7	I/O	VLCD VDD	Pull-down	GPIO/SEG 10/PDI D7/System Clock Output. This is a multifunction pin.
A9	P1.8/S11/D8	I/O	VLCD VDD	Pull-down	GPIO/SEG 11/PDI D8. This is a multifunction pin.
B9	P1.9/S12/D9	I/O	VLCD VDD	Pull-down	GPIO/SEG 12/PDI D9. This is a multifunction pin.
A10	P1.10/S13/D10	I/O	VLCD VDD	Pull-down	GPIO/SEG 13/PDI D10. This is a multifunction pin.
B10	P1.11/S14/D11	I/O	VLCD VDD	Pull-down	GPIO/SEG 14/PDI D11. This is a multifunction pin.
A11	P1.12/S15/D12	I/O	VLCD VDD	Pull-down	GPIO/SEG 15/PDI D12. This is a multifunction pin.
B11	P1.13/S16/D13	I/O	VLCD VDD	Pull-down	GPIO/SEG 16/PDI D13. This is a multifunction pin.
A12	P1.14/S17/D14	I/O	VLCD VDD	Pull-down	GPIO/SEG 17/PDI D14. This is a multifunction pin.
B12	P1.15/S18/D15	I/O	VLCD VDD	Pull-down	GPIO/SEG 18/PDI D15. This is a multifunction pin.
D15	P2.6/S19/TE	I/O	VLCD VDD	Pull-down	GPIO/SEG 19/TE. This is a multifunction pin.
C15	P2.7/S20/TOUTA	I/O	VLCD VDD	Pull-down	GPIO/SEG 20/Timer A Output. This is a multifunction pin.
B15	P2.8/S21	I/O	VLCD VDD	Pull-down	GPIO/SEG 21. This is a dual function pin.
A14	P2.9/S22	I/O	VLCD VDD	Pull-down	GPIO/SEG 22. This is a dual function pin.
A13	P2.10/S23	I/O	VLCD VDD	Pull-down	GPIO/SEG 23. This is a dual function pin.
B13	P2.11/S24	I/O	VLCD VDD	Pull-down	GPIO/SEG 24. This is a dual function pin.
B14	P2.12/S25	I/O	VLCD VDD	Pull-up	GPIO/SEG 25. This is a dual function pin.
D14	P2.13/S26	I/O	VLCD VDD	Pull-up	GPIO/SEG 26. This is a dual function pin.
E15	P2.14/S27	I/O	VLCD VDD	Pull-up	GPIO/SEG 27. This is a dual function pin.
A15	P2.15/S28	I/O	VLCD VDD	Pull-up	GPIO/SEG 28. This is a dual function pin.
F8	P3.8/S29	I/O	VLCD VDD	Pull-up	GPIO/SEG 29. This is a dual function pin.
F9	P3.9/S30	I/O	VLCD VDD	Pull-up	GPIO/SEG 30. This is a dual function pin.
C14	P3.10/S31	I/O	VLCD VDD	Pull-up	GPIO/SEG 31. This is a dual function pin.
E14	P3.11/S32	I/O	VLCD VDD	Pull-up	GPIO/SEG 32. This is a dual function pin.

Pin No.	Mnemonic	I/O ¹	I/O Supply ²	GPIO Pull-Up/Down ²	Description
Miscellaneous Digital Input/Output					
K8	RESETX	I	VCCM_DIG	Pull-up	Reset Pin (Active Low).
L1	P4.0/I2CSCL	I/O	VCCM_DIG	Pull-up	GPIO (External Interrupt 0)/I ² C Clock. This is a dual function pin.
L2	P4.1/I2CSD	I/O	VCCM_DIG	Pull-up	GPIO/I ² C Data. This is a dual function pin.
R1	P4.2/TOUTB	I/O	VCCM_DIG	Pull-up	GPIO/Timer B Output. This is a dual function pin.
R2	P0.10/TOUTC	I/O	VCCM_DIG	Pull-up	GPIO (External Interrupt 8)/Timer C Output. This is a dual function pin.
K2	P0.11	I/O	VCCM_DIG	Pull-up	GPIO (External Clock Input Pin).
N2	BOOT	I	VCCM_DIG	Pull-down	The device enters serial download mode if this pin is held high during, and for a short time after, a reset. It executes user code after any reset event or if the pin is low.
A1	DNC		N/A	N/A	Do Not Connect. Leave this pin floating.
Audio					
K6	P3.12/BEEP/BMCLK	I/O	VCCM_DIG	Pull-down	GPIO/Beeper Output Positive/I ² S Bit Clock. This is a multifunction pin.
K7	P3.13/BEEPX/SDATA	I/O	VCCM_DIG	Pull-down	GPIO/Beeper Output Negative/I ² S Serial Data Output. This is a multifunction pin.
J6	P3.14/LRCLK	I/O	VCCM_DIG	Pull-down	GPIO/I ² S Frame Clock. This is a dual function pin.

¹ S is supply, A is analog input, I is digital input, O is digital output, I/O is digital input/output, and G is ground.

² N/A means not applicable.

TYPICAL PERFORMANCE CHARACTERISTICS

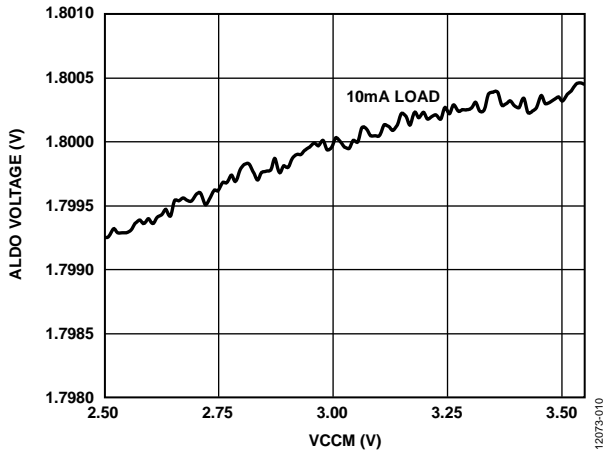

Figure 10. ALDO Line Regulation

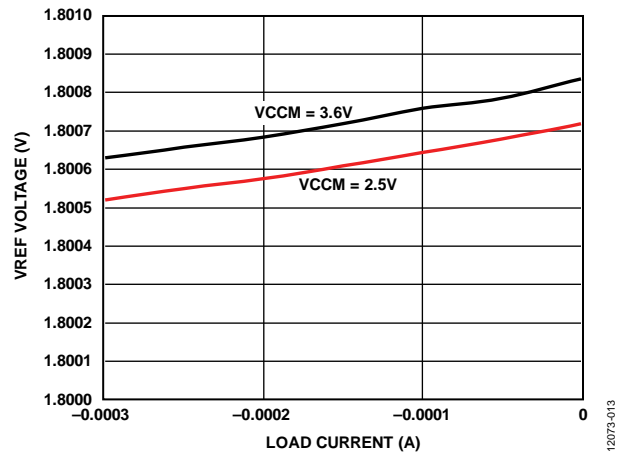

Figure 13. VREF Load Regulation

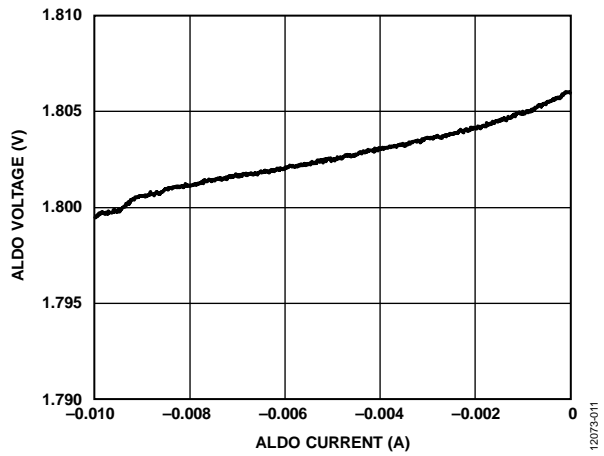

Figure 11. ALDO Load Regulation

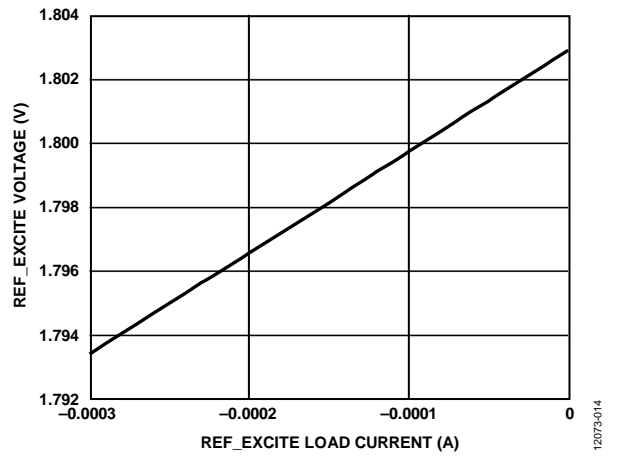

Figure 14. REF_EXCITE Load Regulation

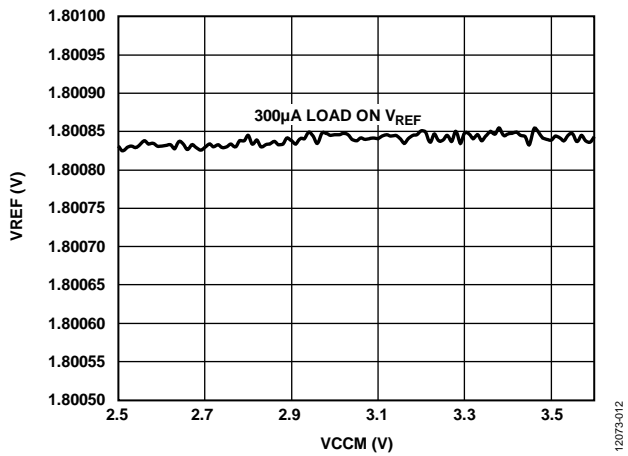

Figure 12. VREF Line Regulation

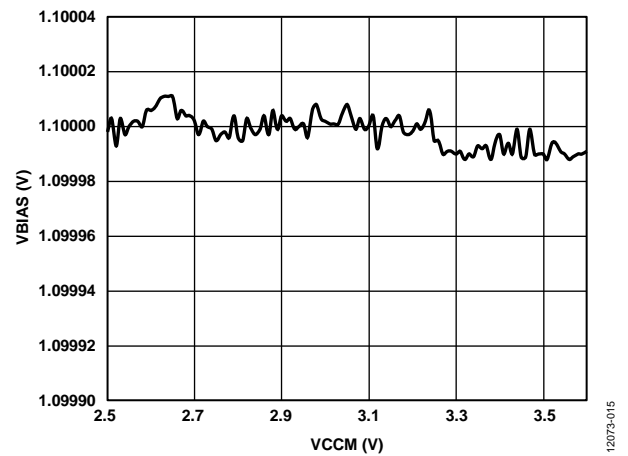

Figure 15. VBIAS Line Regulation

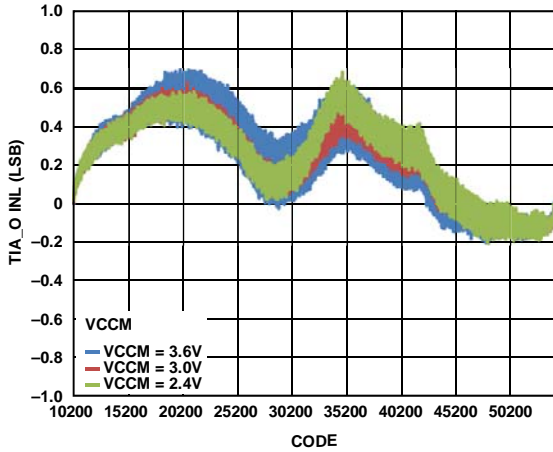

Figure 16. ADC TIA_O INL (16-Bit) vs. Code ($\pm 150 \mu A$)

12073-016

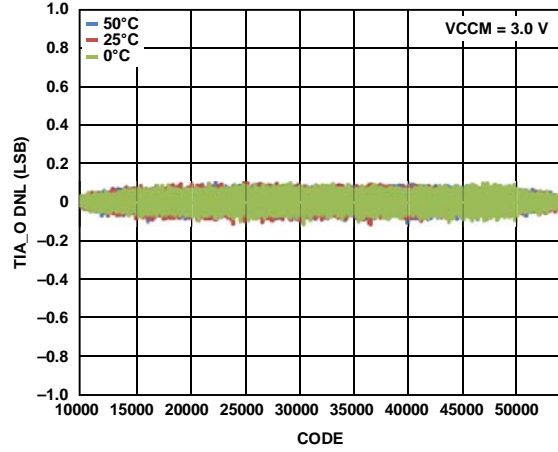

Figure 19. ADC TIA_O DNL (16-Bit) vs. Code (Temperature)

12073-019

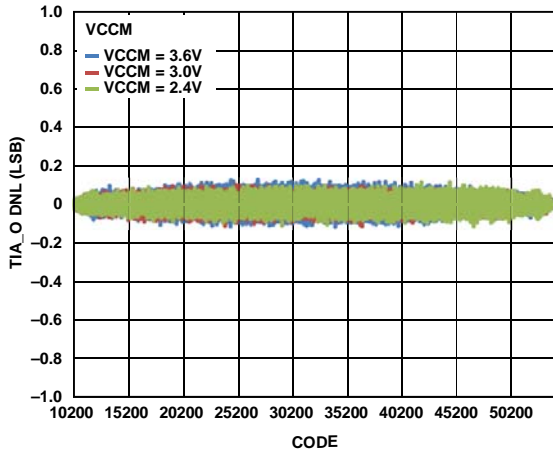

Figure 17. ADC ADC TIA_O DNL (16-Bit) vs. Code

12073-017

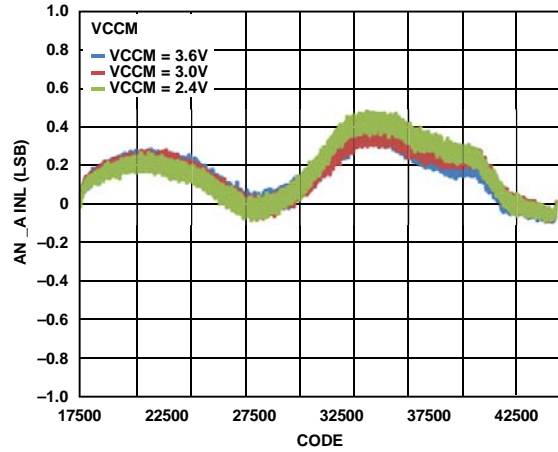

Figure 20. ADC AN_A INL (16-Bit) vs. Code

12073-020

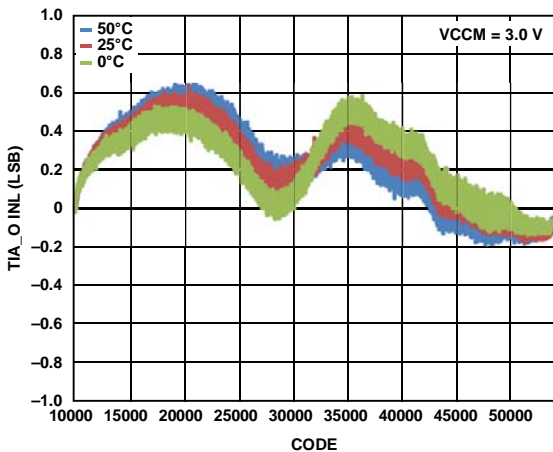

Figure 18. ADC ADC TIA_O INL (16-Bit) vs. Code (Temperature)

12073-018

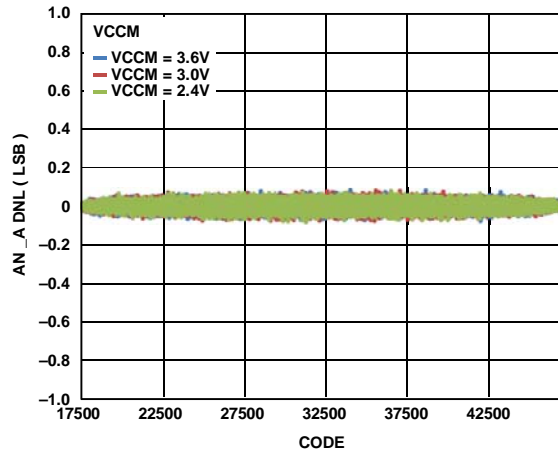

Figure 21. ADC AN_A DNL (16-Bit) vs. Code

12073-021

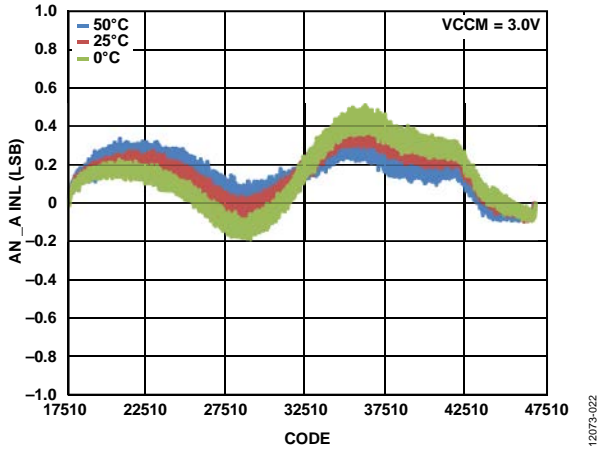

Figure 22. ADC AN_A INL (16-Bit) vs. Code (Temperature)

12073-022

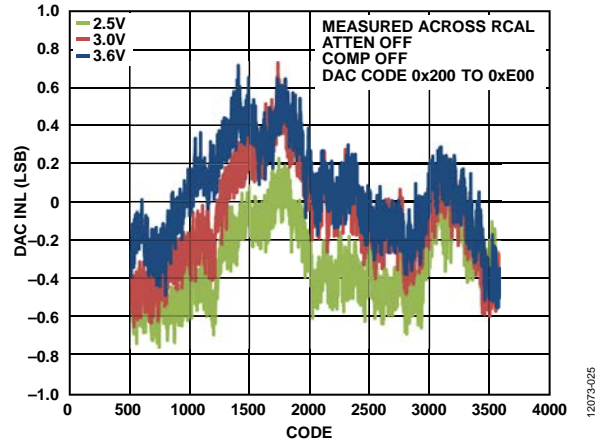

Figure 25. DAC INL (12-Bit) vs. Code

12073-025

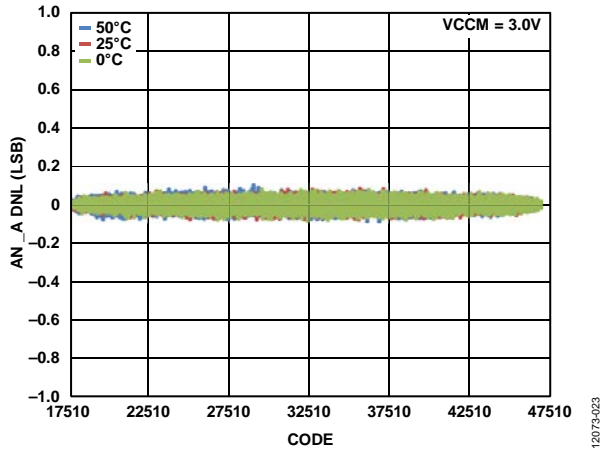

Figure 23. ADC AN_A DNL (16-Bit) vs. Code (Temperature)

12073-023

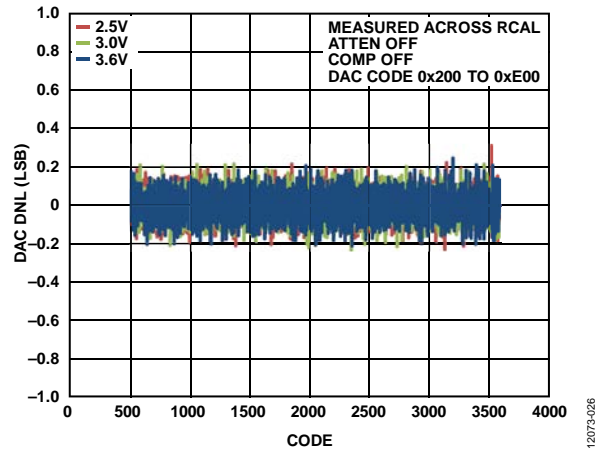

Figure 26. DAC DNL (12-Bit) vs. Code

12073-026

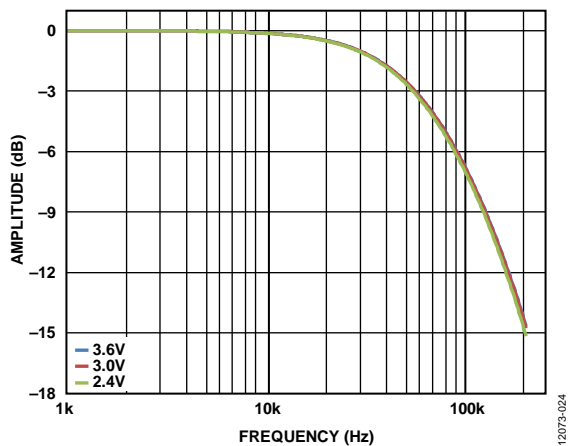

Figure 24. Receive Channel Antialias Filter Roll-Off

12073-024

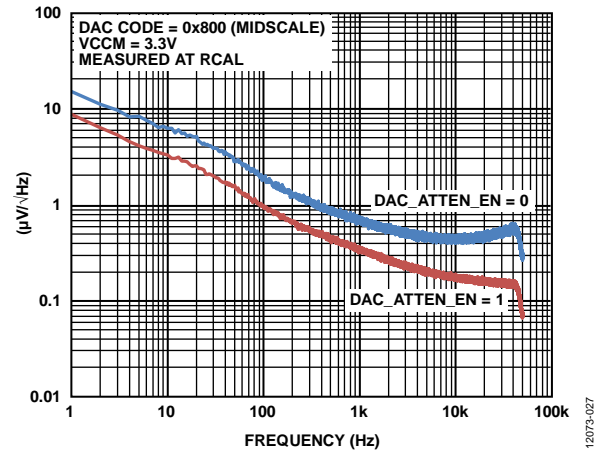

Figure 27. Noise Spectral Density

12073-027

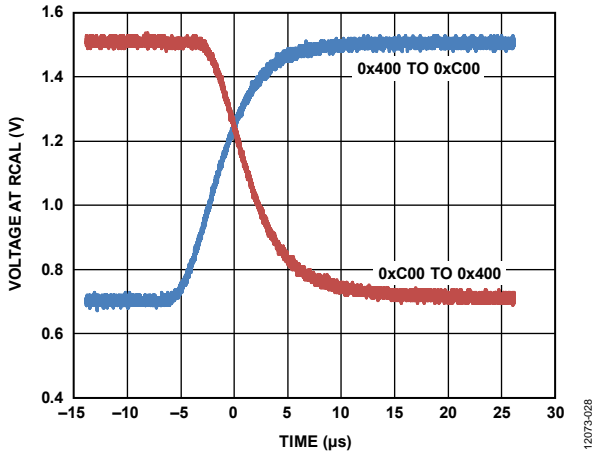

Figure 28. Settling Time of the DAC at RCAL

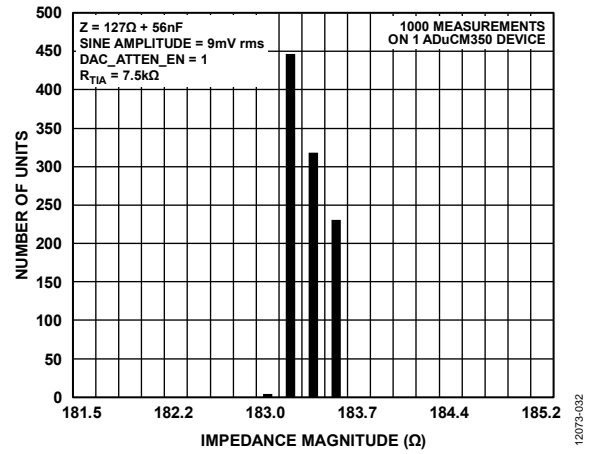

Figure 31. Impedance Measurement Magnitude Precision

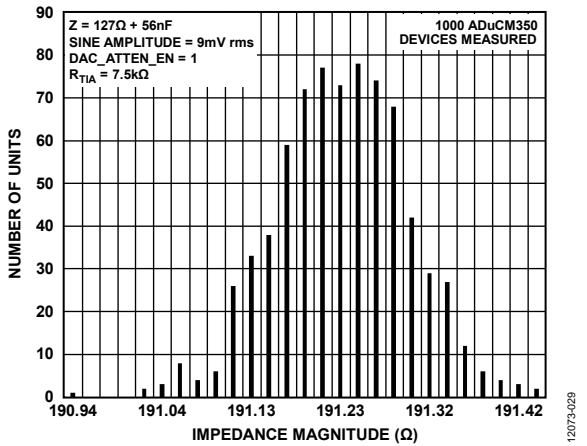

Figure 29. Impedance Measurement Magnitude Accuracy

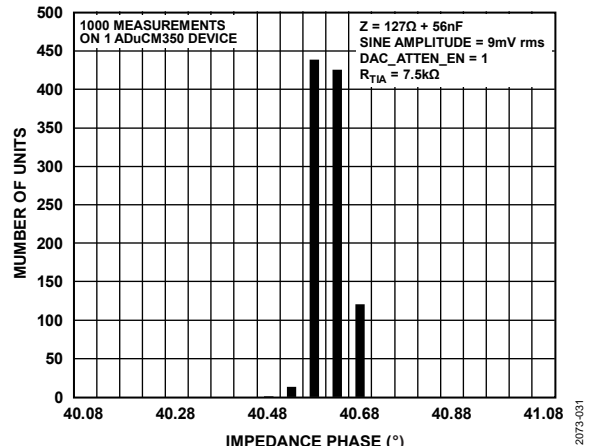

Figure 32. Impedance Measurement Phase Precision

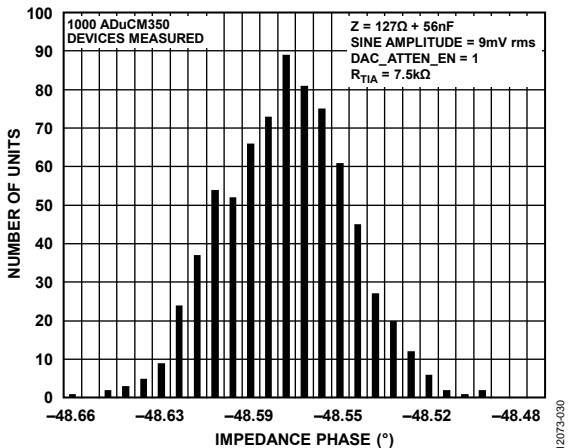

Figure 30. Impedance Measurement Phase Accuracy

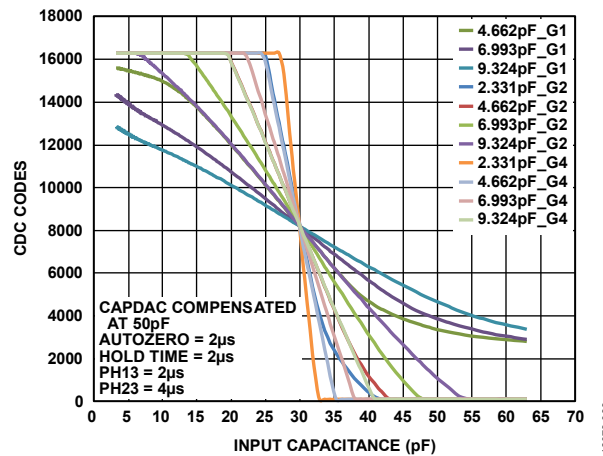

Figure 33. CapTouch Linearity

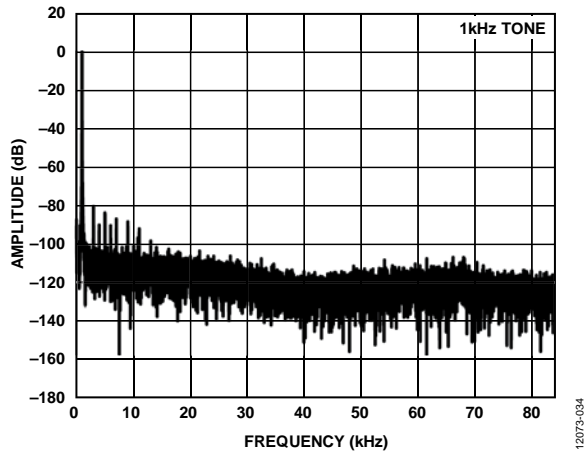

Figure 34. CapTouch SNR

12073-034

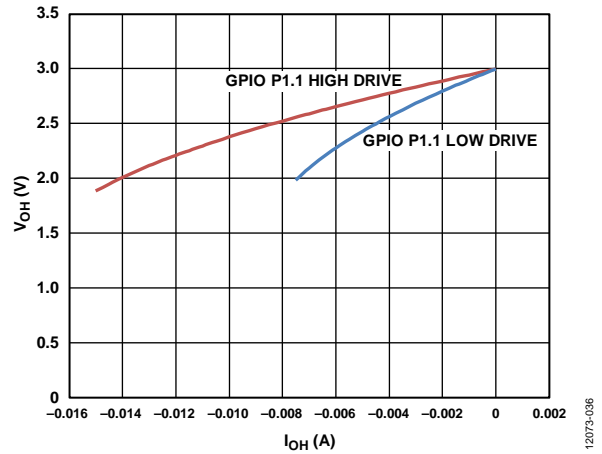

Figure 36. GPIO V_{OH} vs. I_{OH}

12073-036

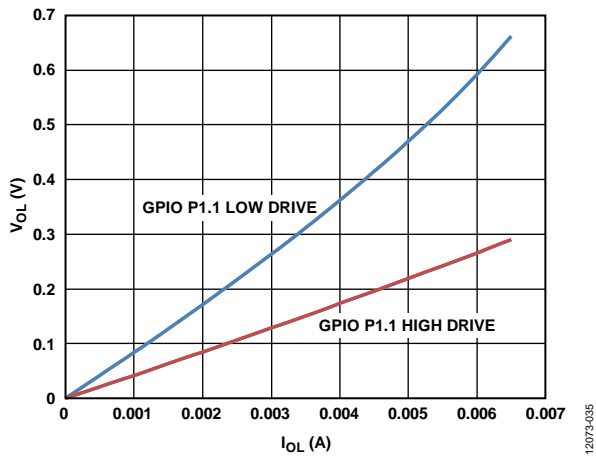

Figure 35. GPIO V_{OL} vs. I_{OL}

12073-035

ANALOG FRONT END

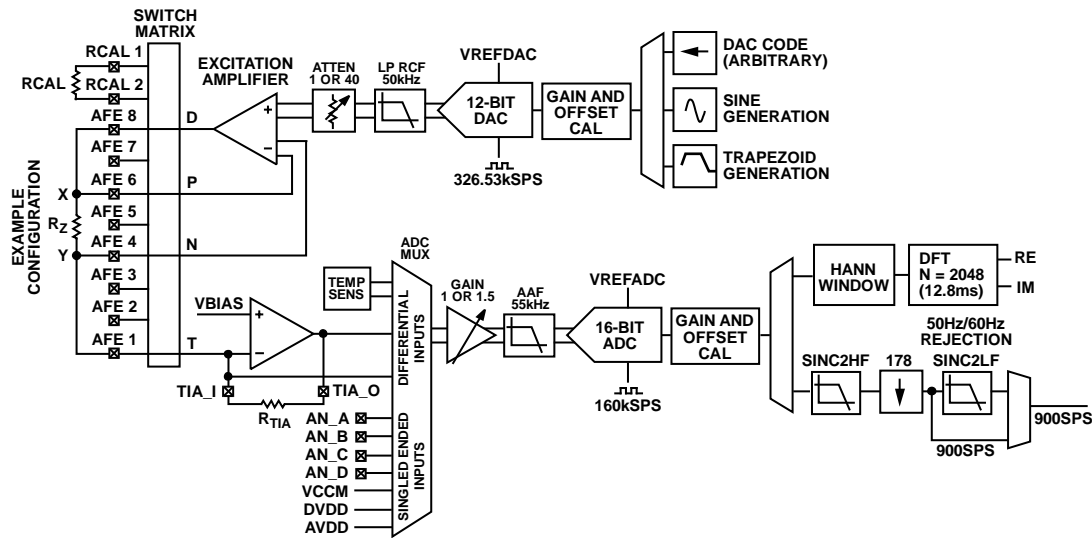

Figure 37. AFE System Block Diagram

For full details on the [ADuCM350](#), refer to the [UG-587](#) hardware reference manual.

The [ADuCM350](#) is a high accuracy, configurable, AFE with a low power, peripheral rich, microcontroller subsystem.

EXCITATION STAGE

The excitation/transmit stage consists of a 12-bit DAC with an excitation buffer and an instrumentation amplifier in a feedback path to the DAC, which forces an accurate voltage across the impedance to be measured, thereby removing parasitics from the measurement system.

All measurements are referenced to a precision external resistor, which is used in the internal calibration loop to ensure no dc bias across an unknown impedance.

A large range of impedances can be measured, depending on the application. Users can optimize the calibration resistor (RCAL), ac amplitude of the excitation waveform, and the current-to-voltage (IV) resistor to tailor fit the system to the application demands. Impedances can be measured from 80 Hz to ~75 kHz.

The switch matrix offers the user full configurability with 34 user selectable switches. The current carrying switches on both excitation buffer output and the transimpedance input are optimally sized for current loads. The switch matrix allows the device to measure and store offset and gain results. The [ADuCM350](#) can self calibrate Rx offset and gain, Tx offset and gain, and switch leakage. This off loads the requirement for an extensive factory calibration routine and removes temperature and aging induced errors from measurements.

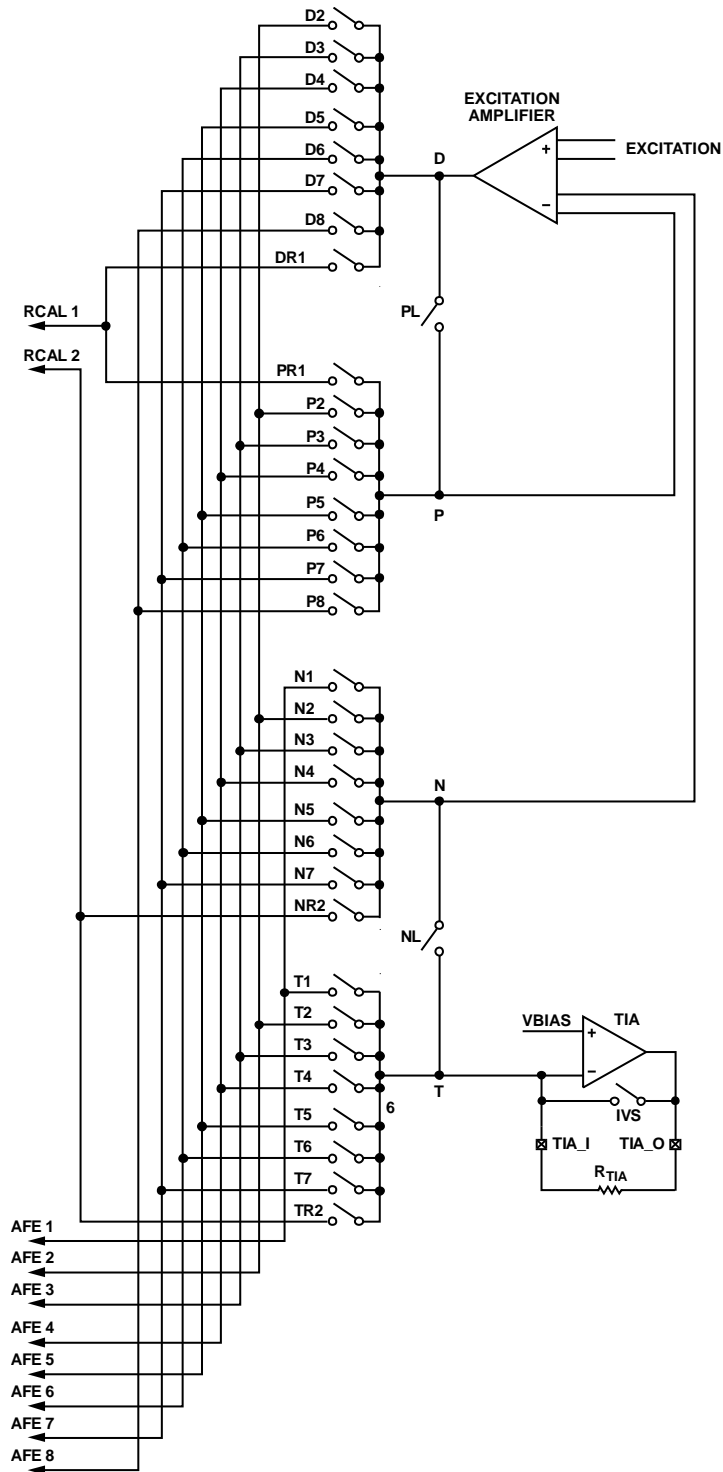

Figure 38. Switch Matrix

12073-038

MEASUREMENT STAGE

The AFE consists of a multiplexed input, 160 kSPS, 16-bit ADC with four dedicated voltage measurement channels and up to eight multiplexed current measurement channels using the on-chip transimpedance amplifier. The multiplexed channels are filtered and differentially buffered prior to data conversion.

The ADC data can be interrogated using three methods.

- By raw data at 160 kSPS.
- At the output of a 50 Hz/60 Hz filter at 900 SPS.
- Through a discrete Fourier transform (DFT) engine.

The power line filter is optimized for fast settling, just 36.6 ms settling. Data at 900 SPS can be further decimated by the user without requiring additional filtering.

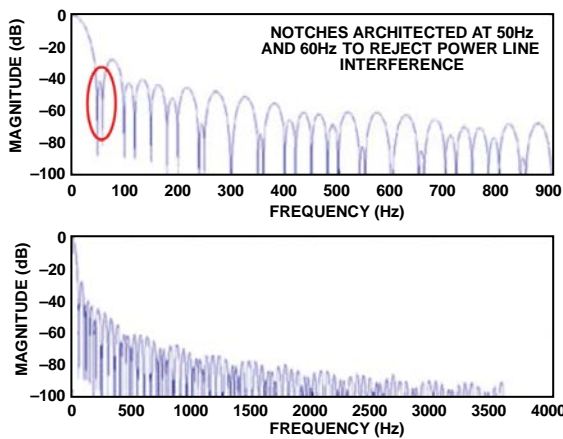

Figure 39. Power Line Rejection Modeling

The DFT engine performs a 2048-point single frequency discrete Fourier transform. It takes the 16-bit ADC output and converts it to complex impedance with real and imaginary components. As the ADC samples at 160 kSPS, this allows for a 79.5 Hz signal energy bandwidth, which gives excellent rejection of interferers.

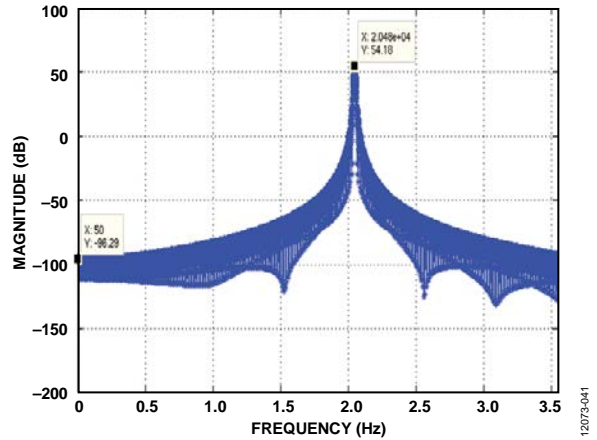

Figure 40. Frequency Response, 2048-Point DFT at 20 kHz

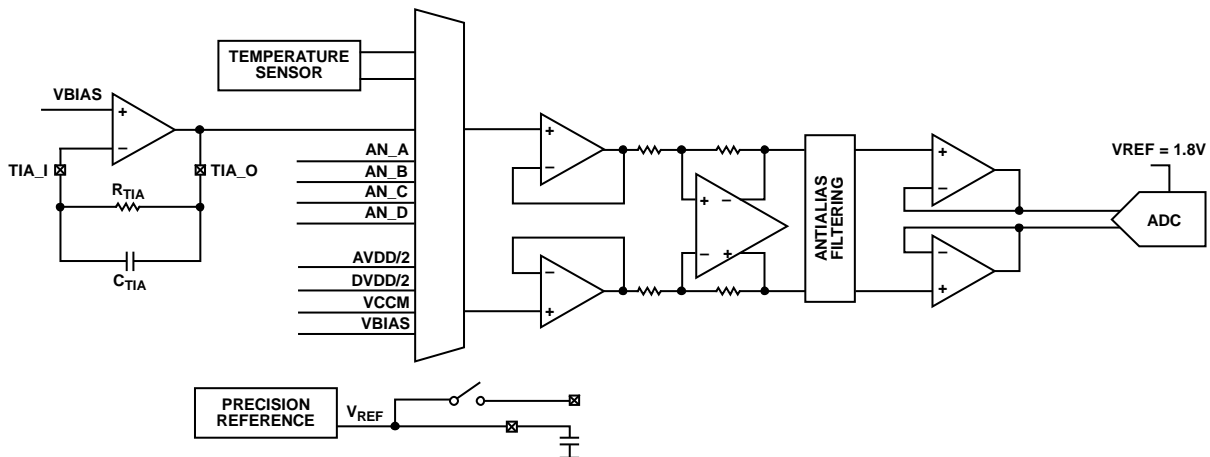

Figure 41. Rx Stage

AFE CONTROL

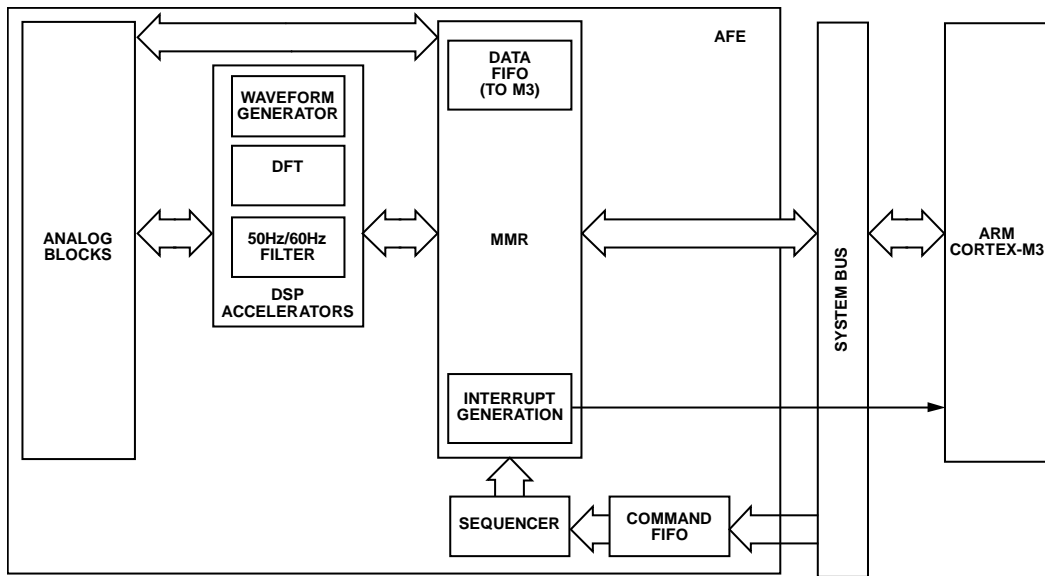

Figure 42. AFE Control

The AFE can be controlled by the ARM Cortex-M3 via MMRs. All blocks within the AFE are fully controllable and observable using the MMR registers. Access the MMRs through an AHB bus or indirectly through a programmable sequencer. There are two dedicated DMA channels to remove burden from the ARM Cortex-M3 to manage data and control FIFOs.

The sequencer handles low level AFE operations and allows the AFE to perform its functions independently. It performs cycle accurate precision AFE measurements asynchronously of the core.

The sequencer allows the user to create parameterized waveforms using the waveform generator block. The waveforms can be trapezoids or sinusoids. Arbitrary waveforms are possible using the AFE sequencer and DMA transfers.

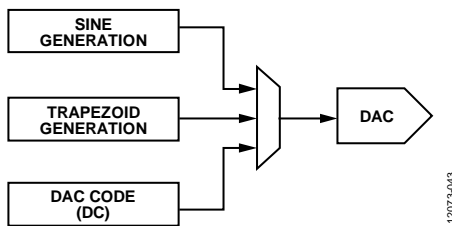

Figure 43. Waveform Generation

CAPTUCH FEATURES

The ADuCM350 incorporates a capacitive touch subsystem that interfaces with up to six capacitive touch channels in self capacitance mode and incorporates high performance capacitance sensing circuitry without external components.

The sensor input configuration is very flexible and uses several techniques to ensure that there are no false touches (that is, no registering touches caused by a changing environment) on the external sensors. To minimize noise pickup from the system, the ADuCM350 CapTouch core includes several algorithms, such as median and averaging filtering measurements, as well as configurable excitation frequency and duty cycle. The subsystem includes a self timer and touch-and-release routines to optimize the power consumption and reduce the computing workload in the ARM Cortex-M3.

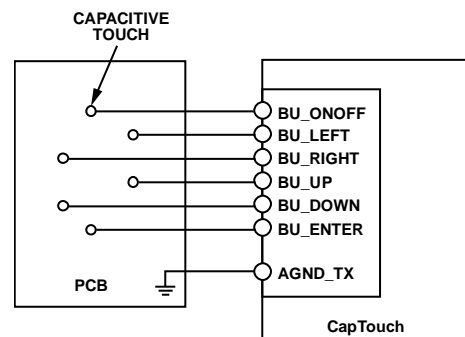

Figure 44. CapTouch External Interface

MICROSUBSYSTEM

MEMORIES

The memory offerings for the [ADuCM350](#) are as follows:

- 384 kB flash.
- 16 kB of flash configured for EEPROM emulation.
- 2 kB user information.
- 32 kB SRAM.
- 2 kB dedicated SRAM for USB endpoint.

Flash

The [ADuCM350](#) includes 384 kB of embedded flash memory, accessed using the flash controller. The flash controller is connected to the bus matrix as a slave device for core and DMA access, as well as the 32-bit AHB for MMR access.

The flash controller supports 384 kB of user space and 2 kB of information space. Read and write to flash are executed via AHB only. The 384 kB flash memory comprises one 256 kB flash array and one 128 kB flash array. The 256 kB flash memory array and 128 kB flash array are controlled by two separate flash controllers with separate register controls.

With respect to flash integrity, the device supports

- Automatic signature check of information space at reset
- User signature for application code
- Parity checking on a per access basis
- 20,000 cycle endurance with 20 ms erase and 20 μ s program
- 100-year data retention at room temperature

General-Purpose Flash

The device contains 16 kB of embedded flash memory for general purpose, such as EEPROM emulation.

SRAM

There is 32 kB of SRAM on chip of which 16 kB is retained during hibernate mode and an optional 16 kB can be retained during hibernate for reduced leakage current.

DEBUG CAPABILITY

The [ADuCM350](#) supports two types of debug host interface: 4-wire JTAG debug (JTAG) interface and a serial 2-wire debug (SWD) interface.

The [ADuCM350](#) incorporates the complete embedded trace of the ARM Cortex-M3 features to maximize code analysis, system profiling, and debugging capabilities.

PROGRAMMABLE GPIOs

The [ADuCM350](#) has 66 GPIO pins, most of which have multiple, configurable functions defined by user code. They can be configured as an input/output and have programmable pull-up or pull-down resistors. All I/O pins are functional over the full supply range (VBAT = 1.8 V to 3.6 V).

In power saving mode, GPIO pins retain state; they tristate on reset to prevent any bus irritation. GPIOs of note are as follows:

- 32 pins multiplexed with LCD segment common pins
- Six pins multiplexed with CapTouch
- Nine pins on a dedicated VDDIO for ease of interfacing to peripherals

TIMERS

General-Purpose Timers

[ADuCM350](#) has three identical general-purpose timers, each with a 16-bit count-up/count-down counter. The count-up/count-down counter can be clocked from one of four user selectable clock sources. Any selected clock source can be scaled down using a prescaler of 16, 256, or 32,768.

Watch Dog Timer (WDT)

The watchdog timer is a 16-bit count-down timer with a programmable prescaler. The prescaler source is selectable and can be scaled by a factor of 1, 16, 256, or 4096. The watchdog timer is clocked either by the 32 kHz crystal oscillator (LFXTAL) or by the 32 kHz on-chip oscillator (LFOSC). The watchdog timer (WDT) is used to recover from an illegal software state. After the WUT is enabled by user code, it requires periodic servicing to prevent it from forcing a reset or interrupt of the processor. A WDT timeout can generate a reset or an interrupt.

Wake-Up Timer

The wake-up timer (WUT) consists of a 32-bit counter clocked from the 32 kHz external crystal (LFXTAL), 32 kHz internal oscillator (LFOSC), or peripheral clock (PCLK). The selected clock source can be scaled

USB

The USB port on the [ADuCM350](#) is a USB 2.0 full speed compliant port. The module consists of the USB controller, USB PHY, USB RAM, and a 2-channel DMA. An integrated regulator powered by VBUS supplies the USB PHY. A dedicated PLL with 60 MHz clock capability is available for clock generation.

The USB supports bulk, isochronous, interrupt, and control modes. It has seven hardware endpoint and a dedicated 2-channel DMA. It supports suspend and wakeup.

The controller hardware is supplemented by a complete set of USB device class drivers to provide complete USB functionality using a defined Micrium stack. The USB stack has a requirement for an RTOS to be on the system. Analog Devices, Inc., has developed its system using the Micrium μ C/OS-II.

POWER MANAGEMENT AND CLOCKING

Power Modes

The PMU provides control of the [ADuCM350](#) power modes and allows the ARM Cortex-M3 to control the clocks and power gating to reduce the dynamic power and hibernate power.

There are four power modes available; each mode provides an additional low power benefit with a corresponding reduction in functionality.

- Active mode—all peripherals can be enabled. Active power is managed by optimized clock management.
- Core sleep—the core is clock gated but the remainder of the system is active. No instructions can be executed in this mode, but DMA transfers can continue between peripherals and memory.
- System sleep—in system sleep, most peripherals are clock gated and are no longer user programmable; the interrupt controller remains active and the NVIC processes wake-up events for a limited number of sources.
- Hibernate mode—some limited state retention, limited number of wake-up interrupts, and the RTC is active.

The device also has a backup mode that supplies minimum power to the RTC and associated circuitry from a super capacitor. The RTC can run for >12 hours with an 80 mF capacitor.

Power Management

The [ADuCM350](#) has an integrated power management system to optimize performance and extend battery life of the device. See the [UG-587](#) hardware reference manual for additional details.

The power management system consists of

- Integrated analog and digital LDOs regulated to 1.8 V.
- Hibernate mode from 2.0 V to 3.6 V.
- High performance AFE measurement from 2.5 V to 3.6 V.
- Integrated power switches for low standby current in hibernate mode.
- Integrated smart diode trickle charger for a super capacitor for use in backup mode.
- Dedicated VDDIO voltage via nine GPIO pins for peripheral interoperability.
- Dedicated regulator for USB transceiver and bus supplied from the VUSB pin.
- Dedicated supervisory circuits for fail safe operation, including power supply monitors of DVDD during flash read/writes, PSM of VCCM to monitor supply during AFE measurements, and PSM on the LFXTAL block to monitor the clock source for RTC.

Clocking

Two on-chip oscillators and driver circuitry for two external crystals are available on the [ADuCM350](#): LFOSC is a 32 kHz

internal oscillator, HFOSC is a 16 MHz internal oscillator, and LFXTAL is a 32 kHz external crystal oscillator, and HFXTAL is a 16 MHz external crystal oscillator.

The [ADuCM350](#) supports either 8 MHz or 16 MHz resonant circuits. The HF RC oscillator has an accuracy of $\pm 5\%$. A low jitter clock source is used for accurate AFE measurements.

The USB has a frequency accuracy requirement of ± 200 ppm. The USB control logic must be clocked at >30 MHz. A USBPHYCLK for clocking the USB PHY is also available and must use a 60 MHz clock.

The low frequency clocking is optimized for ultralow power applications. The RTC requires that the 32.768 kHz XTAL be activated to run for 12 hours off a fully charged 0.08 F super capacitor.

Real Time Clock

The RTC contains a low power crystal oscillation circuit that operates in conjunction with a 32,768 Hz external crystal. It achieves 25 ppm performance in keeping time at 25°C when used with a 10 ppm crystal class load capacitors.

Features of the RTC include

- A 32-bit count register of the time in seconds from a known reference point.
- A prescaler that divides down the 32,768 Hz crystal input to 1 Hz to advance the seconds count.
- RTC alarm and interrupt flags.
- Digital trim capability to allow a positive or negative adjustment to the RTC count at fixed intervals.

DISPLAY OPTIONS

LCD Segment Display Driver and Controller

The [ADuCM350](#) contains an on-chip LCD controller capable of directly driving an LCD panel. For LCD functionality, 36 pins are available on the device.

The LCD controller supports driving up to 128 segments, as well as selectable multiplex option. The static option consists of one backplane \times 32 frontplanes and the 4 \times mux option consists of four backplanes \times 32 frontplanes. The LCD controller also supports LCD waveform voltages that are generated using internal charge pump circuitry and support levels from 2.4 V up to 3.6 V LCDs, programmable frame rates, interrupt generation at the frame boundary (for updating LCD data), and the LCD frame clock (generated by using the on-board 32 kHz crystal).

LCD Display Controller Options

The LCD controller also has the ability to drive external LCD display modules. It has 25 pins for the display interface, which support data transfers of up to 16 bits.

Display controller supports Type A, Type B, and Type C of the MIPI DBI Specification Version 2.0. Specifically, both Fixed-E mode and Clocked-E mode options of the Type A interface are supported, as well as all bus width options (8-/9-/16-bit data) for

Type A and Type B, and 9-bit (Option 1) and 8-bit (Option 3) serial interfaces for Type C.

By using the display controller, the depth on various interfaces is as follows:

- 8-bit interface is 8, 12, or 16 bits per pixel (not 18 or 24).
- 9-bit interface is 18 bits per pixel (not 8, 12, 16, or 24).
- 16-bit interface is 8, 12, or 16 bits per pixel (not 18 or 24).

AUDIO OPTIONS

The [ADuCM350](#) has an integrated audio driver for beeper and an integrated I²S port.

Beeper

The beeper driver module in the [ADuCM350](#) generates a differential square wave of programmable frequency. It drives an external piezoelectric sound component whose two terminals connect to the differential square wave output.

The beeper driver consists of a module that can deliver frequencies from 8 kHz to ~0.25 kHz. It operates on a fixed independent 32 kHz (32,768 Hz) clock source that is unaffected by changes in system clocks.

A timer allows for programmable tone durations from 4 ms to 1.02 sec in 4 ms increments. Single-tone (pulse) and multitone (sequence) modes provide versatile playback options.

In sequence mode, the beeper can be programmed to play any number of tone pairs from 1 to 254 (2 to 508 tones) or be programmed to play forever (until stopped by the user). Interrupts are available to indicate the start or end of any beep, the end of a sequence, or that the sequence is nearing completion.

I²S

The device supports I²S. The purpose of the I²S port is to provide audio data to an amplifier, which drives a small speaker. The I²S features available on the [ADuCM350](#) include the following:

- Data samples of up to 24 bits.
- Frame clocks from 8 kHz to 192 kHz.
- Master/slave mode.
- 8-deep Tx FIFOs.
- DMA mode with address autoincrement.
- Interrupt mode.
- Downsampling transfers.

DEVELOPMENT SUPPORT

DOCUMENTATION

The [ADuCM350](#) hardware reference manual details the functionality of each block on the [ADuCM350](#). It includes power management, clocking, memories, peripherals, and the AFE.

HARDWARE

The EVAL-ADuCM350EBZ evaluation kit is available to prototype a user's sensor configuration with the [ADuCM350](#). A selection of daughter cards are available to interrogate peripheral performance, including CapTouch, PDI, LCD segment, beeper, and I²S.

SOFTWARE

The EVAL-ADuCM350EBZ includes a complete development and debug environment for the [ADuCM350](#). The software

development kit (SDK) for the [ADuCM350](#) uses the IAR Embedded Workbench for ARM as its development environment.

The SDK consists of full working AFE examples of power-up sequences, calibration sequences, and measurement routines. These AFE example routines are documented in the [UG-587](#) hardware reference manual with supporting timing diagrams.

The SDK also includes operating system (OS) aware drivers and example code for all the peripherals on the device, including SPI, I²C, CapTouch, PDI, and so forth.

Also available in the support package is the [ADuCM350](#) AFE development GUI that operates from the National Instruments LabVIEW® environment. This GUI allows the user to rapidly prototype different sensors with the [ADuCM350](#) AFE to evaluate its high precision performance.

PACKAGING AND ORDERING INFORMATION

OUTLINE DIMENSIONS

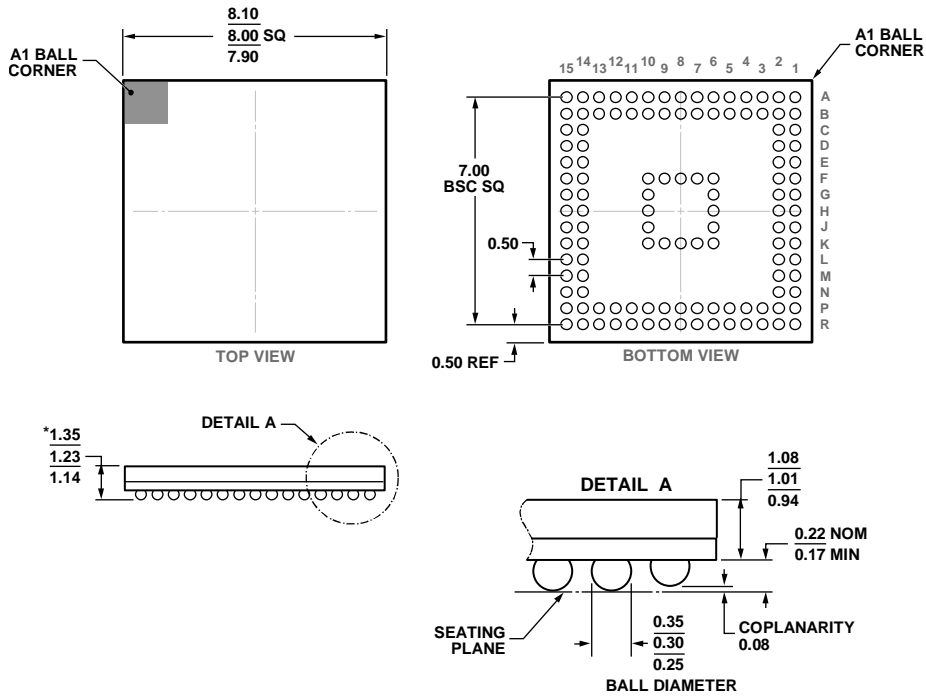

*COMPLIANT TO JEDEC STANDARDS MO-275-CCCE-1 WITH EXCEPTION TO PACKAGE HEIGHT.

04-02-2015-A

Figure 45. 120-Ball Chip Scale Package Ball Grid Array [CSP_BGA] (BC-120-3)
Dimensions shown in millimeters

ORDERING GUIDE

Model ¹	Temperature Range	Package Description	Package Option
ADuCM350BBCZ	-40°C to +85°C	120-Ball Chip Scale Package Ball Grid Array [CSP_BGA]	BC-120-3
ADuCM350BBCZ-RL	-40°C to +85°C	120-Ball Chip Scale Package Ball Grid Array [CSP_BGA]	BC-120-3

¹ Z = RoHS Compliant Part.

NOTES

NOTES

I²C refers to a communications protocol originally developed by Philips Semiconductors (now NXP Semiconductors).