

HTx2-600

$$V_{\text{DRM}} = 600 \text{ V}$$

$$I_{\text{T(RMS)}} = 2.0 \text{ A}$$

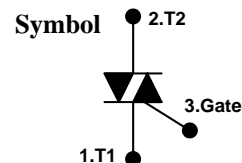

FEATURES

- Repetitive Peak Off-State Voltage: 600V
- R.M.S On-state Current ($I_{\text{T(RMS)}}=2\text{A}$)
- High Commutation dv/dt

1.T1 2. T2 3. Gate

TO-126



HTC2-600

TO-126ML



HTM2-600

General Description

The Triac HTx2-600 is suitable for AC switching application, phase control application such as heater control, motor control, lighting control, and static switching relay.

Absolute Maximum Ratings $(T_a=25^\circ\text{C})$

Symbol	Parameter	Value	Units
V_{DRM}	Repetitive Peak Off-State Voltage	600	V
$I_{\text{T(RMS)}}$	R.M.S On-State Current ($T_a = 66^\circ\text{C}$)	1.5	A
I_{TSM}	Surge On-State Current (One Cycle, 50/60Hz, Peak, Non Repetitive)	13/15	A
V_{GM}	Peak Gate Voltage	6	V
I_{GM}	Peak Gate Current	0.5	A
P_{GM}	Peak Gate Power Dissipation	1	W
T_{STG}	Storage Temperature Range	-40 to +125	$^\circ\text{C}$
T_j	Operating Temperature Range	-40 to +125	$^\circ\text{C}$

Electrical Characteristics ($T_a=25^\circ\text{C}$)

Symbol	Parameter	Test Conditions		Min	Typ	Max	Units
I_{GT}	Gate Trigger Current	$V_D=6V, R_L=10\Omega$	1+, 1-, 3-			20	mA
V_{GT}	Gate Trigger Voltage	$V_D=6V, R_L=10\Omega$	1+, 1-, 3-			1.5	V
V_{GD}	Non Trigger Gate Voltage	$T_j=125^\circ\text{C}, V_D=1/2V_{DRM}$		0.2			V
$(dv/dt)_c$	Critical Rate of Rise of Off-State Voltage at Communication	$T_j=125^\circ\text{C}, V_D=2/3V_{DRM}$ $(di/dt)_c=-0.75A/ms$		5			V/ μs
I_H	Holding Current				5		mA
I_{DRM}	Repetitive Peak Off-State Current	$V_D=V_{DRM}$, Single Phase, Half Wave, $T_j=125^\circ\text{C}$				0.5	mA
V_{TM}	Peak On-State Voltage	$I_T=6A$, Inst, Measurement				1.6	V

Thermal Characteristics

Symbol	Parameter	Test Conditions	Min	Typ	Max	Units
$R_{TH(J-C)}$	Thermal Resistance	Junction to Case			6.25	$^\circ\text{C}/\text{W}$

Performance Curves

Fig 1. Gate Characteristics

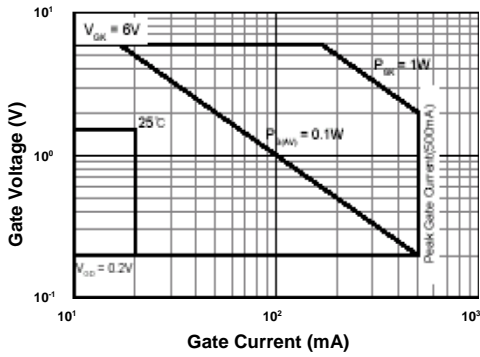

Fig 2. On-State Voltage

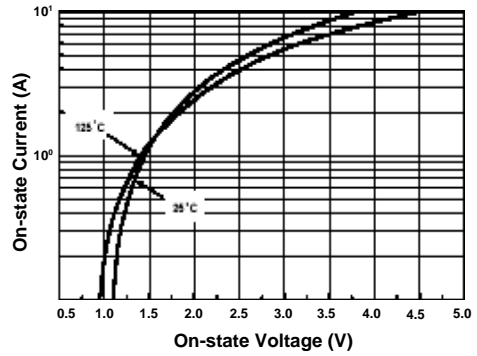

Fig 3. Gate Trigger Voltage vs. Junction Temperature

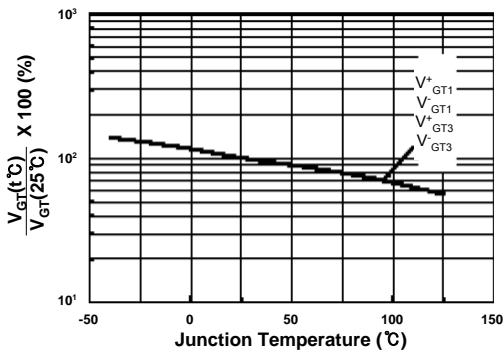

Fig 4. On State Current vs. Maximum Power Dissipation

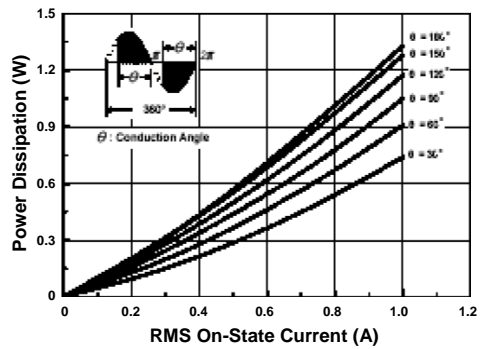

Fig 5. On State Current vs. Allowable Case Temperature

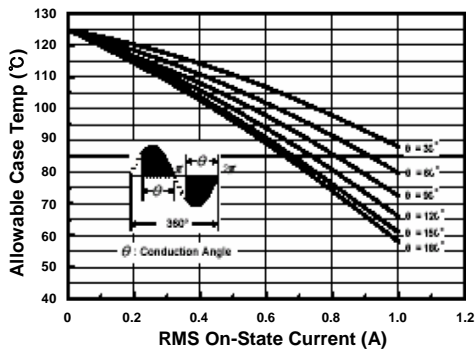

Fig 6. Surge On-State Current Rating (Non-Repetitive)

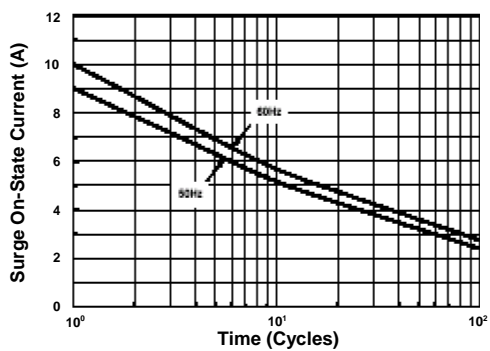

Fig 7. Gate Trigger Current vs. Junction Temperature

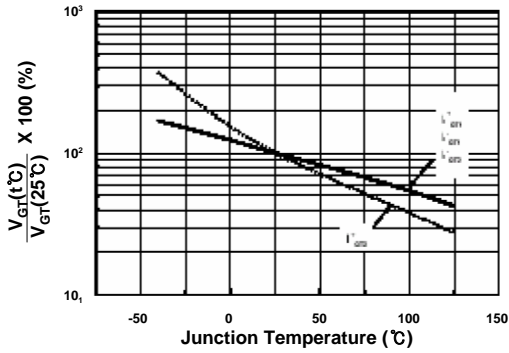

Fig8. Transient Thermal Impedance

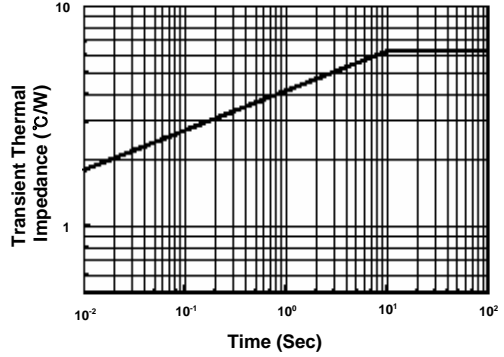
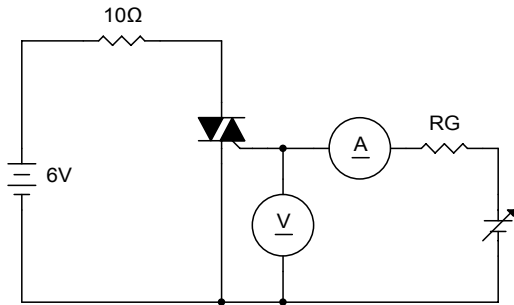
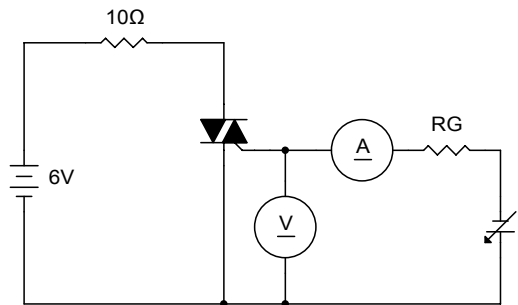

Fig 7. Gate Trigger Characteristics Test Circuit



Test Procedure I



Test Procedure II

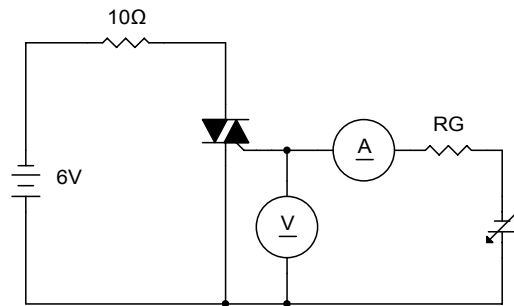

Test Procedure III

Package Dimension

HTC2-600
(TO-126)

DIM	Millimeters
A	8.5max
B	12.0max
C	13.0min
D	3.8±0.2
G	0.78±0.08
G1	1.2
H	2.8max
H3	1.27
K	2.5±0.2
L	2.3max
φ	3.20±0.2

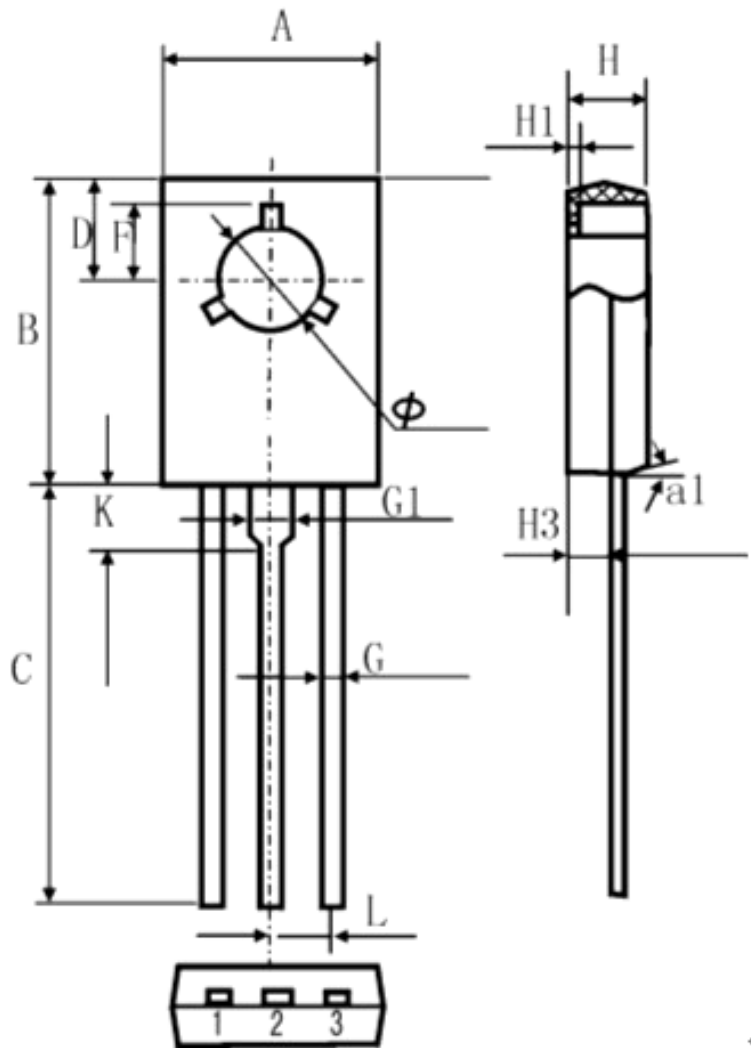

Dimensions in Millimeters

Package Dimension

**HTM2-600
(TO-126ML)**

corresponding symbol	measurement
A(mm)	7.99 ± 0.25
B(mm)	11.12 ± 0.25
C(mm)	14.5 ± 0.5
E(mm)	3.625 ± 0.125
F(mm)	1.4 ± 0.12
G(mm)	0.76 ± 0.08
G1(mm)	1.3 ± 0.12
H(mm)	3.57 ± 0.13
H3(mm)	2.01 ± 0.13
I(mm)	2.99 ± 0.38
K(mm)	1.0 ± 0.12
L(mm)	2.3MAX
$\phi 1$ (mm)	3.0 ± 0.12

