



ISA-WELD® // PRECISION RESISTORS

BKW



Features

- Independent from temperature because of lowest TCR-values
- Extremely good long-term stability, thus the energy meters do not require any recalibration
- Permanent current up to 100 A (0.3 mOhm)
- Qualified for 20 A-, 40 A-, 60 A- and 80 A-energy-meters
- Massive copper terminals
- Very high reproducibility of R-value and TCR
- Mounting: Screwed on terminals of kWh-meter



Applications

- Ideal for single and three phase energy meters
- Battery current sensing

Technical data

Resistance values	mOhm	0.3 / 0.4 / 0.5
Tolerance	%	5
Temperature coefficient (20-60 °C)	ppm/K	<20
Applicable temperature range	°C	-55 to +140
Power rating	W	3
Internal heat resistance (R_{thi})	K/W	<10
Inductance	nH	<3
Stability (Nominal load) deviation after 2,000 h T_k = Terminal temperature		<0.5% ($T_k = 110\text{ °C}$)

Ordering code

BKW - M - R0003 - 5.0

.....	Tolerance
.....	Resistance value [Ohm] / „R“ represents decimal point
.....	Material (MANGANIN®)
.....	Type

Packaging Information

500 pcs. sealed in plastic bags evacuated and refilled with dry nitrogen



BKW

Mechanical dimensions [mm]

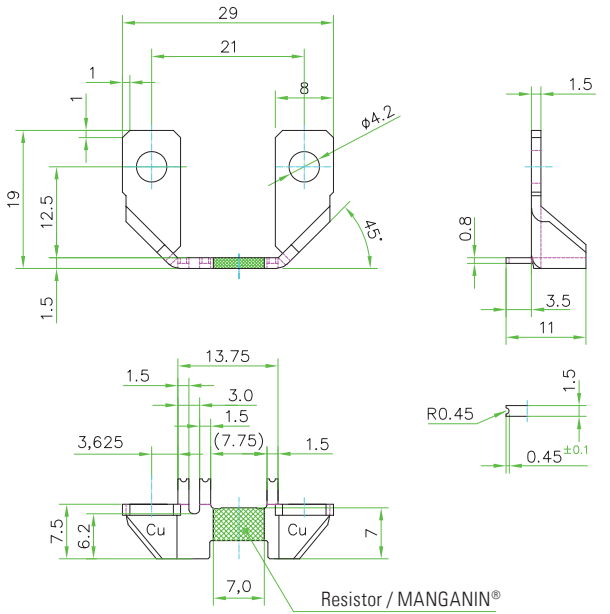

Connection diagram

Connection diagram for sense leads

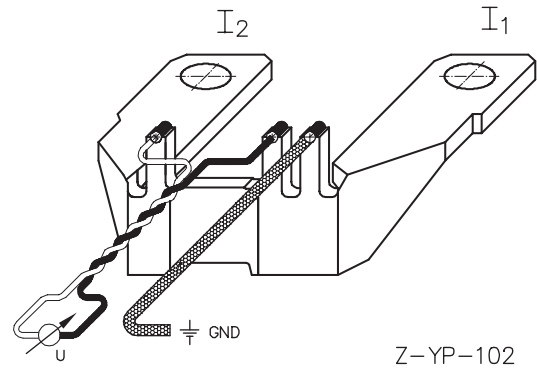

Connection diagram

Sense terminal connection on pc-board (bottom view)

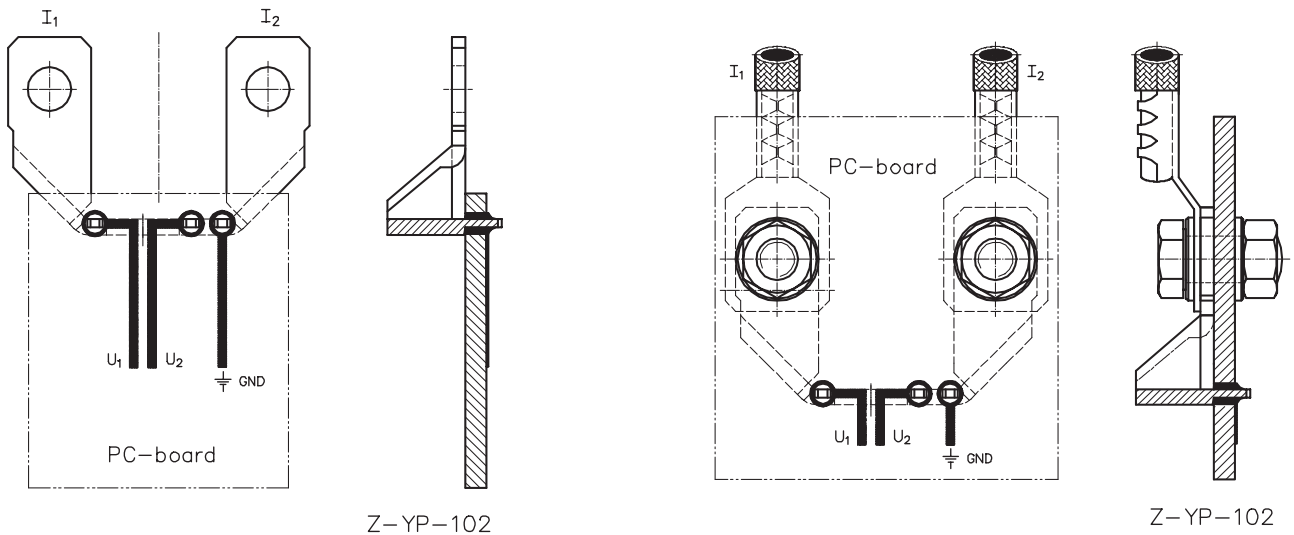

Recommended solder profile

Reflow-, IR-soldering, wave-soldering upon request

Temperature [°C]	260	255	217
Time [s]	Peak	40	90



BKW

Temperature dependence of the electrical resistance

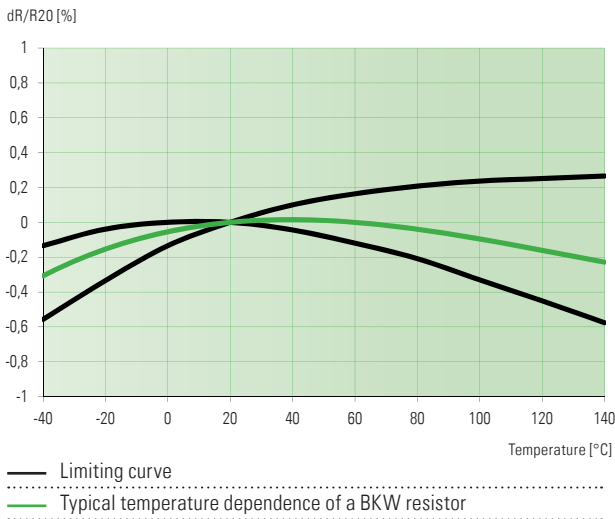

Power derating curve

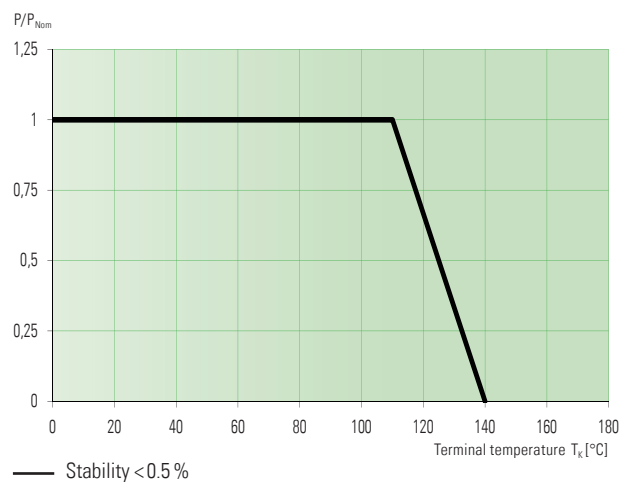

Maximum pulse energy respectively pulse power for permanent operation

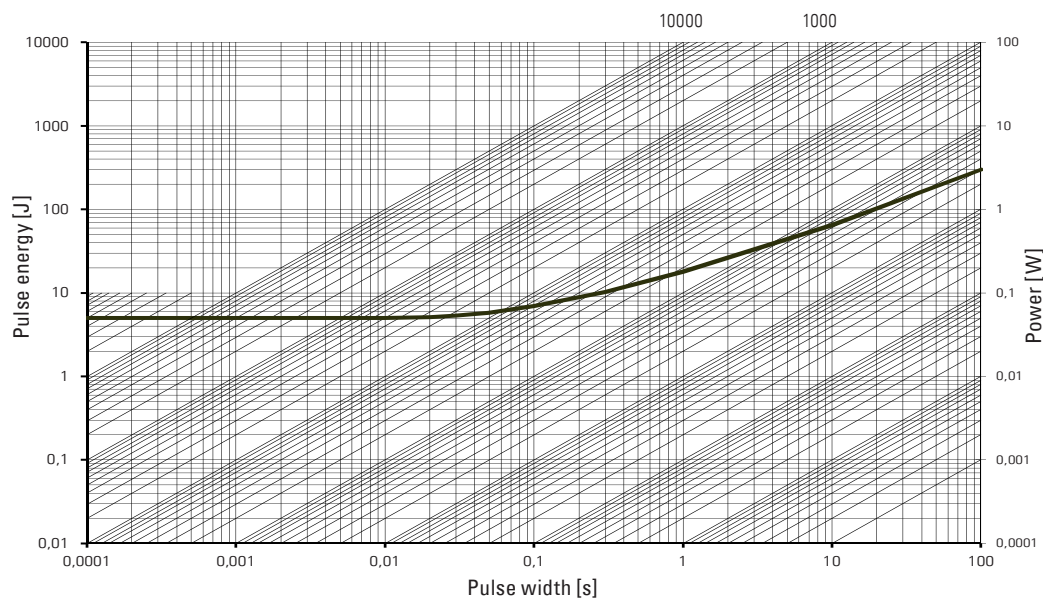

This curve is only valid for the resistance value R0003. The progression of the curve in the lower range could be different for other resistance values. Therefore a separate qualification should be made in thresholds.

Disclaimer // All products, product specifications and data are subject to change without notice.

The product specifications do not expand or otherwise modify Isabellenhütte's terms and conditions of sale, including but not limited to, the warranty expressed therein. Isabellenhütte makes no warranty, representation or guarantee other than as set forth in its terms and conditions of sale. Information provided in datasheets and/or specifications may vary from actual results in different applications. Any statements made by Isabellenhütte regarding the suitability of products for certain types of applications are based on its knowledge of typical requirements that are often placed on its products. It is the customer's responsibility to validate that a particular product with the properties described in the product specification is suitable for use in the application intended.

No license, express or implied, or otherwise, to any intellectual property rights is granted by this document.

Any and all liability arising out of the application or use of any product shall be as set forth in Isabellenhütte's terms and conditions of sale.

