

Silicon Schottky Diodes

BAT 15- ... D

- Beam lead technology
- Low dimension
- High performance
- Low barrier

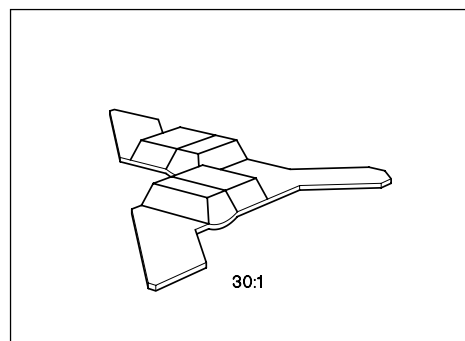

ESD: Electrostatic discharge sensitive device, observe handling precautions!

Type	Marking	Ordering Code	Pin Configuration	Package ¹⁾
BAT 15-020 D	–	Q62702-D1263		D
BAT 15-050 D		Q62702-D3450		
BAT 15-090 D		Q62702-D1280		
BAT 15-110 D		Q62702-D1289		

Maximum Ratings

Parameter	Symbol	Values		Unit
		BAT 15-020 D BAT 15-050 D	BAT 15-090 D BAT 15-110 D	
Reverse voltage	V_R	4	4	V
Forward current	I_F	100	50	mA
Junction temperature	T_j	175		°C
Storage temperature range	T_{stg}	– 65 ... + 150		
Operating temperature range	T_{op}	– 65 ... + 150		

¹⁾ For detailed information see chapter Package Outlines.

Electrical Characteristics

at $T_A = 25\text{ °C}$, unless otherwise specified.

Parameter	Symbol	Values			Unit
		min.	typ.	max.	

DC Characteristics

Breakdown voltage $I_R = 10\text{ }\mu\text{A}$	$V_{(BR)}$	4	–	–	V
Diode capacitance $V_R = 0, f = 1\text{ MHz}$	C_T				pF
BAT 15-020 D		–	0.30	0.35	
BAT 15-050 D		–	0.20	0.25	
BAT 15-090 D		–	0.14	0.15	
BAT 15-110 D		–	0.10	0.12	
Forward voltage $I_F = 1\text{ mA}$	V_F				V
BAT 15-020 D		–	0.26	–	
BAT 15-050 D		–	0.28	–	
BAT 15-090 D		–	0.30	–	
BAT 15-110 D		–	0.31	–	
$I_F = 10\text{ mA}$					
BAT 15-020 D		–	0.35	–	
BAT 15-050 D		–	0.39	–	
BAT 15-090 D		–	0.44	–	
BAT 15-110 D		–	0.45	–	
Single sideband noise figure $F_{IF} = 1.5\text{ dB}, P_{LO} = 0\text{ dBm}, f_{IF} = 10.7\text{ MHz}$	F_{SSB}				dB
$f = 3.0\text{ GHz}$		–	6.0	–	
$f = 6.0\text{ GHz}$		–	6.5	–	
$f = 9.3\text{ GHz}$		–	6.5	–	
$f = 16\text{ GHz}$		–	7.0	–	
Differential forward resistance $I_F = 10\text{ mA}$	r_f				Ω
BAT 15-020 D		–	3.5	–	
BAT 15-050 D		–	4.0	–	
$I_F = 50\text{ mA}$					
BAT 15-090 D		–	7.0	–	
BAT 15-110 D		–	10.0	–	