

AZ763

12 A SPDT MINIATURE POWER RELAY

FEATURES

- Dielectric strength 5000 Vrms
- Low height: 15.7 mm
- Epoxy sealed version available
- 12 Amp switching
- AC and DC coils
- Isolation spacing greater than 10 mm
- Proof tracking index (PTI/CTI) 250
- Reinforced insulation, EN 60730-1 (VDE 0631, part 1) EN 60335-1 (VDE 0700, part 1)
- UL, CUR file E43203
- VDE certificate 40012572



CONTACTS

Arrangement	SPDT (1 Form C) SPST (1 Form A)
Ratings	Resistive load: Max. switched power: 360 W or 3000 VA Max. switched current: 12 A Max. switched voltage: 300 VDC* or 400 VAC * Note: If switching voltage is greater than 30 VDC, special precautions must be taken. Please contact the factory.
Rated Load UL, CUR VDE	12 A at 250 VAC, General use [1][2] 1 Form A - DC coil 12 A at 250 VAC, 50k cycles, 85°C [1] 12 A at 250 VAC, 10k cycles, 85°C [2] 1 Form A - AC coil 12 A at 250 VAC, 60k cycles, 70°C [1][2] 1 Form C - DC coil 12 A at 250 VAC, 50k cycles, 85°C [1] 12 A at 250 VAC, 10k cycles, 85°C [2] 1 Form C - AC coil 12 A at 250 VAC, 60k cycles, 70°C [1] 12 A at 250 VAC, 10k cycles, 70°C [2]
Material	Silver nickel [1], silver tin oxide [2] gold plating available
Resistance	< 100 milliohms initially

COIL

Power	
At Pickup Voltage (typical)	200 mW (DC coil) .422 VA (AC coil)
Max. Continuous Dissipation	1.7 W at 20°C (68°F) ambient 1.7 VA at 20°C (68°F) ambient
Temperature Rise	26°C (47°F) at nominal coil voltage
Max. Temperature	155°C (311°F) Class F

GENERAL DATA

Life Expectancy Mechanical Electrical	Minimum operations 3 x 10 ⁷ 1 x 10 ⁵ at 12 A 250 VAC res.
Operate Time (typical)	7 ms at nominal coil voltage
Release Time (typical)	3 ms at nominal coil voltage (with no coil suppression)
Dielectric Strength (at sea level for 1 min.)	5000 Vrms coil to contact 1000 Vrms between open contacts
Insulation Resistance	10 ⁵ megohms min. at 500 VDC, 20°C, 50% RH
Insulation (according to DIN VDE 0110, IEC 60664-1)	B250 at 1 Form C, flux proof version C250 at other relay versions Overvoltage category: III Pollution degree: 3 Nominal voltage: 250 VAC
Dropout DC coils AC coils	Greater than 10% of nominal coil voltage Greater than 15% of nominal coil voltage
Ambient Temperature Operating	At nominal coil voltage -40°C (-40°F) to 85°C (185°F) - DC coils -40°C (-40°F) to 70°C (158°F) - AC coils
Vibration	Break contacts: 5 g at 20...500 Hz Make contacts: 20 g at 30...500 Hz
Shock	20 g
Enclosure	P.B.T. polyester, UL-94 : V0
Terminals	Tinned copper alloy, P.C.
Max. Solder Temp.	270°C (518°F)
Max. Solder Time	5 seconds
Max. Solvent Temp.	80°C (176°F)
Max. Immersion Time	30 seconds
Weight	14 grams
Packing unit in pcs	20 per carton tube / 1000 per carton box

NOTES

1. All values at 20°C (68°F).
2. Relay may pull in with less than "Must Operate" value.
3. Specifications subject to change without notice.

ZETTLER electronics GmbH

Junkersstr. 3, D-82178 Puchheim, Germany

phone: +49 89 800 97-0 office@ZETTLERelectronics.com
fax: +49 89 800 97-200 www.ZETTLERelectronics.com

This product specification to be used only together with the application notes which can be downloaded from <http://www.ZETTLERelectronics.com/pdfs/relais/ApplicationNotes.pdf>

2013-02-26

AZ763

RELAY ORDERING DATA

COIL SPECIFICATIONS - DC COIL				ORDER NUMBER*	
Nominal Coil VDC	Must Operate VDC	Max. Continuous VDC	Coil Resistance Ohm $\pm 10\%$	3.5 mm STD	5 mm Left
3	2.1	7.6	22	AZ763-1C-3D	AZ763L-1C-3D
5	3.5	12.7	60	AZ763-1C-5D	AZ763L-1C-5D
6	4.2	15.3	90	AZ763-1C-6D	AZ763L-1C-6D
9	6.3	22.9	200	AZ763-1C-9D	AZ763L-1C-9D
12	8.4	30.6	360	AZ763-1C-12D	AZ763L-1C-12D
18	12.6	45.9	710	AZ763-1C-18D	AZ763L-1C-18D
24	16.8	61.2	1,440	AZ763-1C-24D	AZ763L-1C-24D
36	25.2	92.0	3,140	AZ763-1C-36D	AZ763L-1C-36D
48	33.6	122.0	5,700	AZ763-1C-48D	AZ763L-1C-48D
60	42.0	153.0	7,500	AZ763-1C-60D	AZ763L-1C-60D
110	77.0	280.0	25,200	AZ763-1C-110D	AZ763L-1C-110D

COIL SPECIFICATIONS - AC COIL					ORDER NUMBER*	
Nominal Coil VAC	Must Operate VAC	Max. Continuous VAC	Nominal Current mA $\pm 10\%$	Coil Resistance Ohm $\pm 10\%$	3.5 mm STD	5 mm Left
12	9.0	18.0	63.0	100	AZ763-1C-12A	AZ763L-1C-12A
24	18.0	36.0	31.3	400	AZ763-1C-24A	AZ763L-1C-24A
48	36.0	72.0	15.6	1,550	AZ763-1C-48A	AZ763L-1C-48A
60	45.0	90.0	12.5	2,600	AZ763-1C-60A	AZ763L-1C-60A
110	82.5	165.0	6.8	8,900	AZ763-1C-110A	AZ763L-1C-110A
115	86.3	172.5	6.5	9,600	AZ763-1C-115A	AZ763L-1C-115A
120	90.0	180.0	6.3	10,200	AZ763-1C-120A	AZ763L-1C-120A
220	165.0	330.0	3.4	35,500	AZ763-1C-220A	AZ763L-1C-220A
230	172.5	345.0	3.3	38,500	AZ763-1C-230A	AZ763L-1C-230A
240	180.0	360.0	3.1	42,500	AZ763-1C-240A	AZ763L-1C-240A

* For right spacing substitute "AZ763R" for "AZ763L". Substitute "1A" for "1C" for 1 Form A contacts. "1A" or "1C" denote silver nickel contacts. Add "G" to "1A" or "1C" for gold plated silver nickel contacts. Add "E" to "1A" or "1C" for silver tin oxide contacts. Add suffix "E" at the end of order number for sealed version.

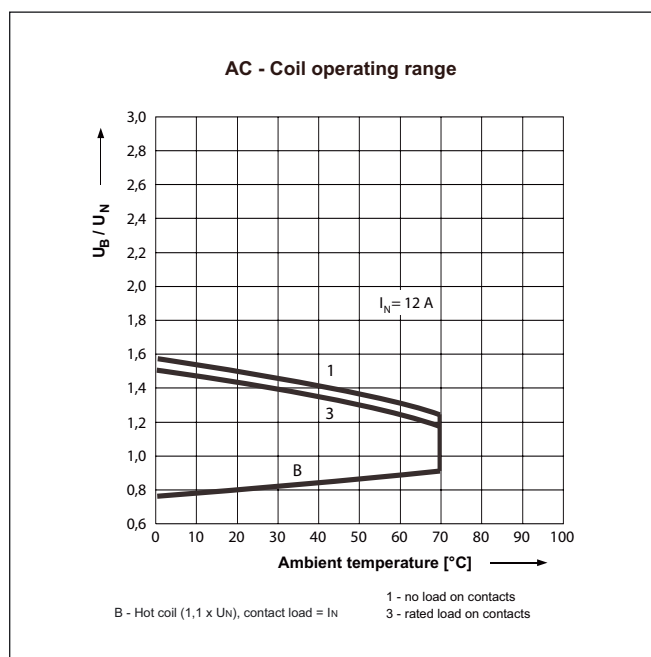
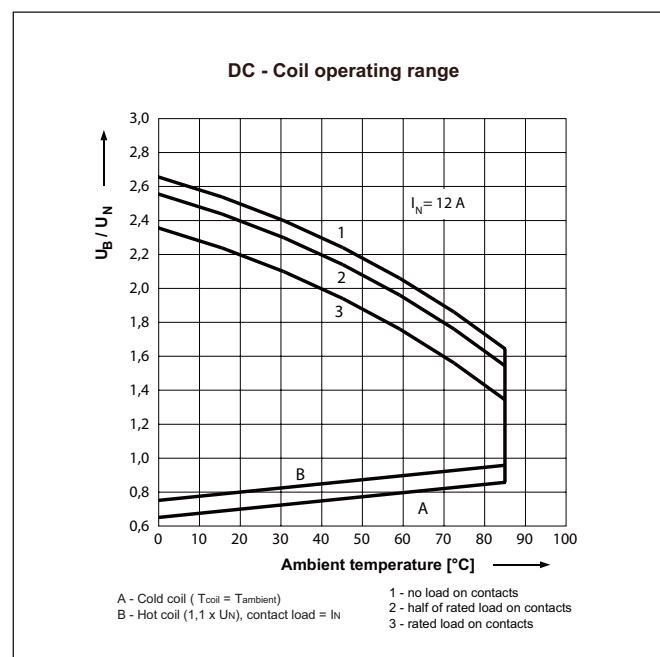

ZETTLER electronics GmbH

Junkersstr. 3, D-82178 Puchheim, Germany

phone: +49 89 800 97-0 office@ZETTLERelectronics.com

fax: +49 89 800 97-200 www.ZETTLERelectronics.com

This product specification to be used only together with the application notes which can be downloaded from <http://www.ZETTLERelectronics.com/pdfs/relais/ApplicationNotes.pdf>

2013-02-26

AZ763

MECHANICAL DATA

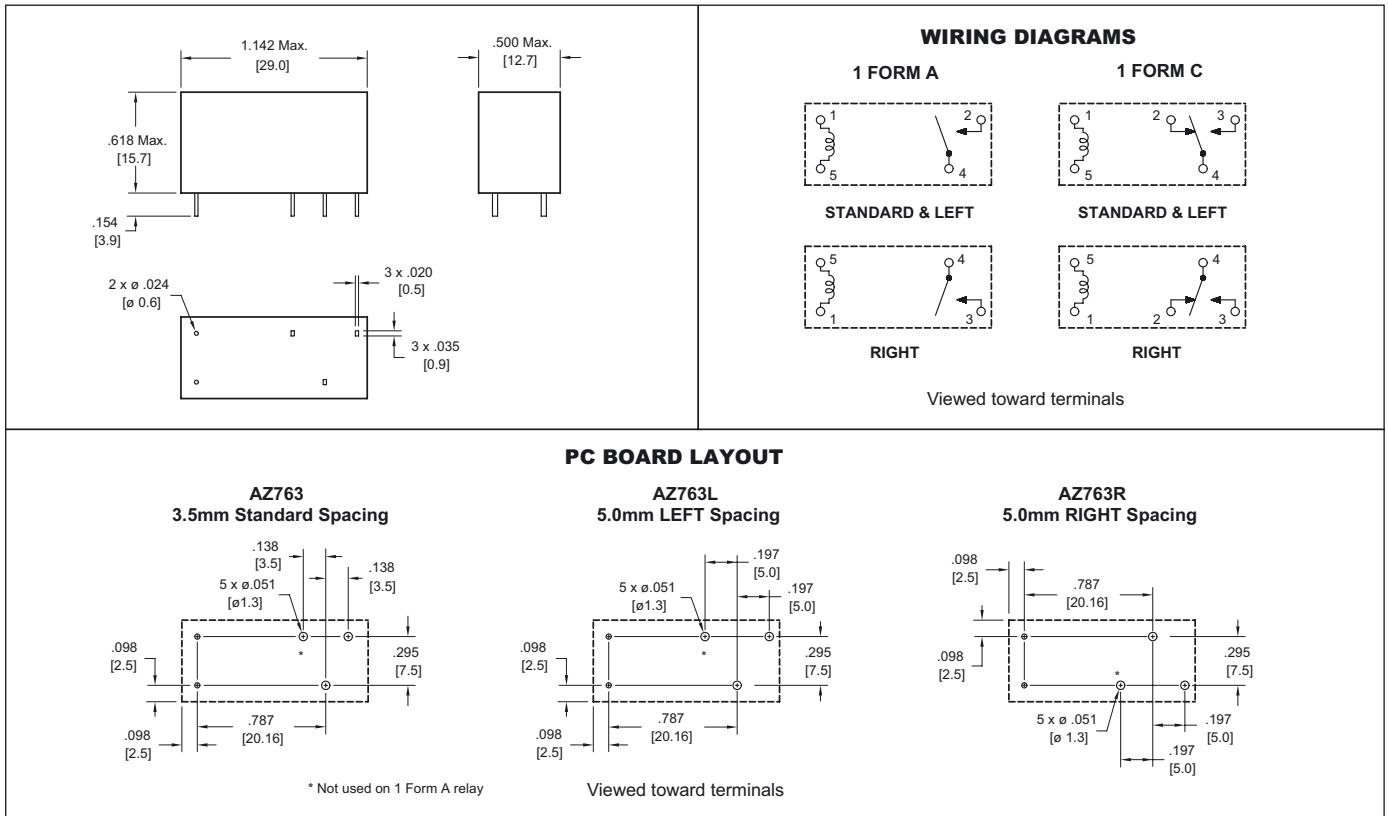

Dimensions in inches with metric equivalents in parentheses. Tolerance: $\pm .010''$

ACCESSORIES

For P.C.B. mount: Socket EC 35 (EC 50 for R and L)
Retaining Clip MP 16 / MH 16



For DIN rail mount: Socket ES 35 (ES 50 for R and L)
Retaining Clip MS 16

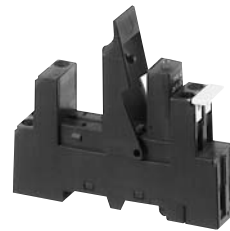

MECHANICAL DATA

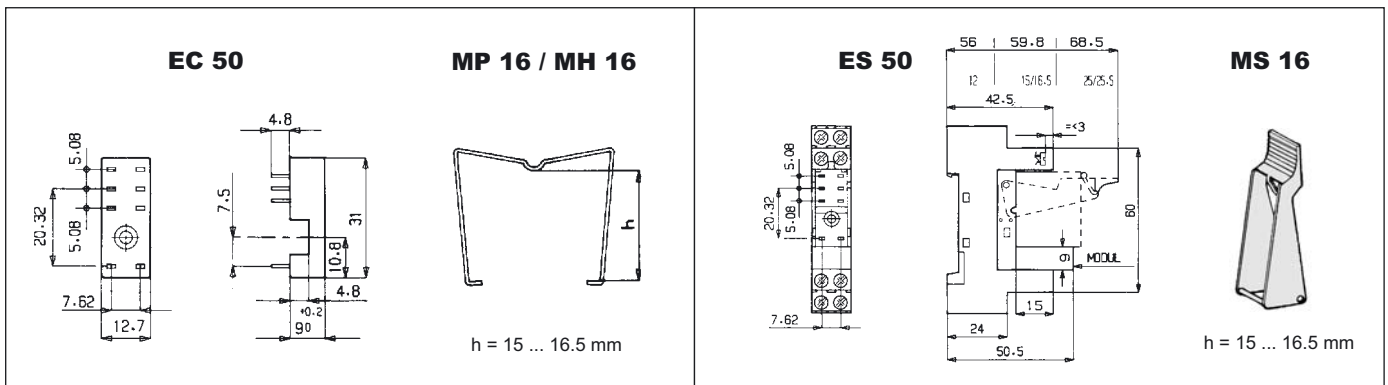

ZETTLER electronics GmbH

Junkersstr. 3, D-82178 Puchheim, Germany

phone: +49 89 800 97-0 office@ZETTLERelectronics.com

fax: +49 89 800 97-200 www.ZETTLERelectronics.com

This product specification to be used only together with the application notes which can be downloaded from <http://www.ZETTLERelectronics.com/pdfs/relais/ApplicationNotes.pdf>

2013-02-26

Electrical life at 250 VAC, resistive load

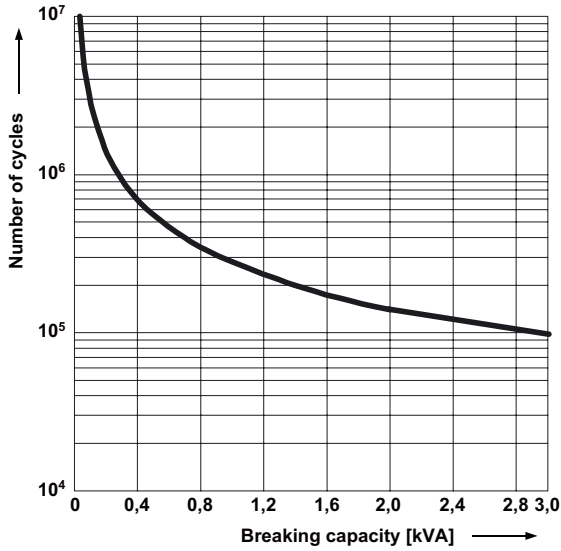

Electrical life reduction factor at inductive AC load

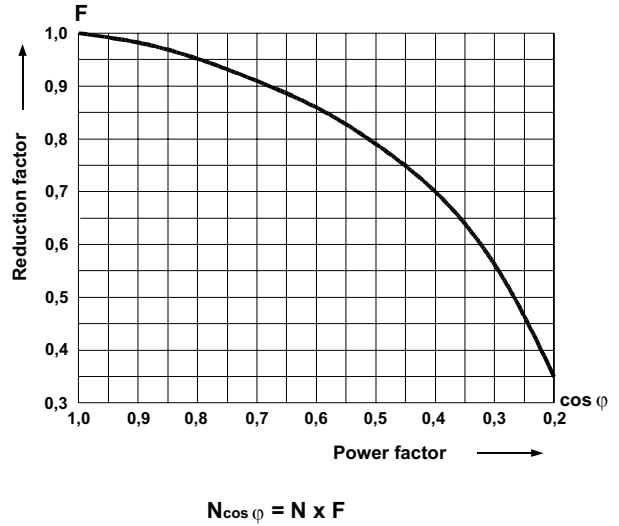

Max. DC resistive load breaking capacity

