

9325812 UNITED MICROELECTRONICS

92D 00697

D T-99-15-02



# UM3273

ADVANCED PRODUCT DESCRIPTION

## 3 1/2 -Digit Multiplexed LCD Alarm Clock

### Features

- 3 1/2-digit 2-function clock in hour and minute
- Alarm clock in hour and minute
- Snooze function
- Direct 1/2-duty multiplexed LCD drive capability
- Single 1.5V battery operation
- Voltage doubler
- Alarm sound demonstration capability
- 7 switches (with pull-down resistors)
- Low power dissipation
- 32.768KHz crystal controlled operation
- Push-pull driving buffer for buzzer
- Special trigger output for switch control
- Power-on reset
- Colon flash or freeze by mask option

### General Description

UM3273 is a low threshold voltage, metal-gate CMOS IC that provides all signals needed to drive a 1/2-duty multiplexed LCD clock of 3 1/2 digits.

The circuit time base is a 32.768KHz crystal controlled oscillator, oscillator RC network components are included in the circuit, the UM3273 operates on a single 1.5V battery.

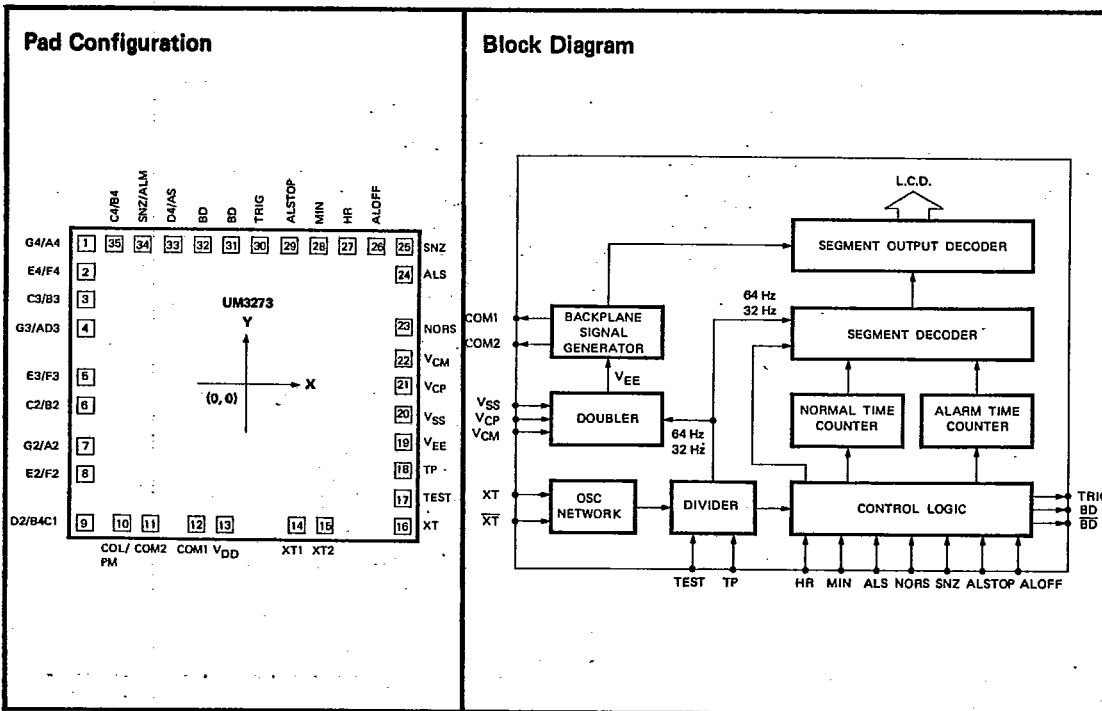

9325812 UNITED MICROELECTRONICS

92D 00698

DT-49-15-02



UM3273

**Absolute Maximum Ratings\***

DC Supply Voltage ..... -0.3V to 5.0V  
 Input/Output Voltage .....  $V_{SS} - 0.2V$  to  $V_{DD} + 0.2V$   
 Operating Ambient Temperature .....  $-10^{\circ}C$  to  $60^{\circ}C$   
 Storage Temperature .....  $-55^{\circ}C$  to  $125^{\circ}C$

**\*Comments**

Stress above those listed under "Absolute Maximum Ratings" may cause permanent damage to the device. These are stress ratings only. Functional operation of this device at these or any other conditions above those indicated in the operational sections of this specification is not implied and exposure to absolute maximum rating conditions for extended periods may affect device reliability.

**Electrical Characteristics**

( $V_{SS} = 0V$ ,  $V_{DD} = 1.5V$ ,  $F_{OSC} = 32.768$  KHz,  $T_A = 25^{\circ}C$ , unless otherwise specified.)

| Parameter                       | Symbol       | Limits |                      |      | Unit    | Test Condition                    |
|---------------------------------|--------------|--------|----------------------|------|---------|-----------------------------------|
|                                 |              | Min.   | Typ.                 | Max. |         |                                   |
| Supply Voltage                  | $V_{DD}$     | 1.2    | 1.5                  | 1.65 | V       |                                   |
| Supply Current                  | $I_{DD}$     | -      | -                    | 3    | $\mu A$ | LCD Unload<br>BD, BD, TRIG Open   |
| Voltage Doubler Supply          | $V_{EE}$     | -1.1   | -1.44                | -    | V       |                                   |
| Oscillator Starting Time        | $T_{OSC}$    | -      | -                    | 1.0  | S       | $V_{DD} = 1.45V$                  |
| Alarm Output Drive Current      | $I_{BD}$     | 200    | -                    | -    | $\mu A$ | $V_{BD} = 1V$                     |
| Frequency Stability             | $\Delta F/F$ | -      | -                    | 1    | ppm     | $V_{DD} = 1.35 \sim 1.65V$        |
| Trigger Current                 | $I_{TR}$     | 200    | 250                  | -    | $\mu A$ | $V_{DD} = 1.5V$ , $V_{OH} = 1.2V$ |
| LCD Drive Current               | $I_{LCD}$    | 0.1    | -                    | -    | $\mu A$ |                                   |
| Switch Chatter Time             | $T_{ct}$     | -      | -                    | 60   | ms      |                                   |
| Oscillator Built-in Capacitance | $C_D$        | -      | 20                   | -    | PF      |                                   |
| Alarm Output Frequency          | $F_{BD}$     | -      | 4096x8x1<br>4096x8x½ | -    | Hz      |                                   |

9325812 UNITED MICROELECTRONICS

92D 00699

DT-49-15-02



UM3273

Pad Description

| Pad No. | Designation     | Description                            |
|---------|-----------------|--|
| 1       | G4/A4           | LCD Segment Drive                      |
| 2       | E4/F4           |  |
| 3       | C3/B3           |  |
| 4       | G3/AD3          |  |
| 5       | E3/F3           |  |
| 6       | C2/B2           |  |
| 7       | G2/A2           |  |
| 8       | E2/F2           |  |
| 9       | D2/BC1          |  |
| 10      | COL/PM          |  |
| 11      | COM2            | Backplane Common 2                     |
| 12      | COM1            | Backplane Common 1                     |
| 13      | V <sub>DD</sub> | Positive Power Supply                  |
| 14      | XT <sub>1</sub> | Oscillator Input Pin                   |
| 15      | XT <sub>2</sub> | Oscillator Input Pin                   |
| 16      | XT              | Built-in Capacitance Pin               |
| 17      | TEST            | Test Pin                               |
| 18      | TP              | Test Pin                               |
| 19      | V <sub>EE</sub> | Voltage Doubler Supply                 |
| 20      | V <sub>SS</sub> | Ground                                 |
| 21      | V <sub>CP</sub> | Voltage Doubler Capacitor Positive Pin |
| 22      | V <sub>CM</sub> | Voltage Doubler Capacitor Negative Pin |
| 23      | NORS            | Normal Time Mode Set Pin               |
| 24      | ALS             | Alarm Time Mode Set Pin                |
| 25      | SNZ             | Snooze Operation Pin                   |
| 26      | ALOFF           | Alarm Off Pin                          |
| 27      | HR              | Hour Digit Set Pin                     |
| 28      | MIN             | Minute Digit Set Pin                   |
| 29      | ALSTOP          | Alarm Stop Pin                         |
| 30      | TRIG            | Alarm Trigger Pin for Switch Control   |
| 31      | BD              | Piezo Buzzer Driving Pin               |
| 32      | BD              | Piezo Buzzer Driving Pin               |
| 33      | D4/AS           | LCD segment Drive                      |
| 34      | SNZ/ALM         |  |
| 35      | C4/B4           |  |

9325812 UNITED MICROELECTRONICS

92D 00700

DT-49-15-02



UM3273

Function Description

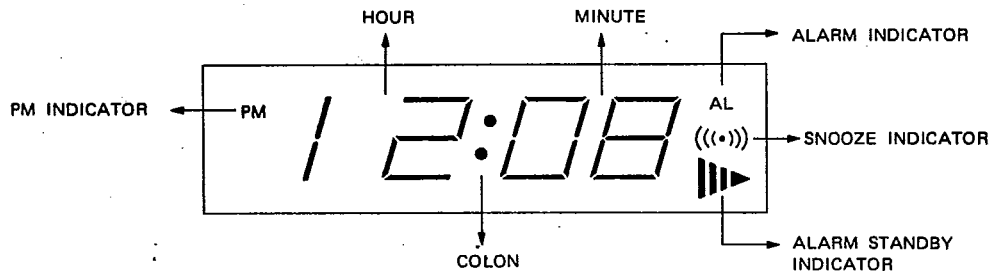

- PM indicator on from 12:00 PM to 11:59 PM off from 12:00 AM to 11:59 AM
- Colon on in alarm time mode, and 0.5 sec on 0.5 sec off normal time mode
- Alarm time indicator on in alarm time mode off in normal time mode
- Snooze indicator on in snooze stand-by mod 0.5 sec on 0.5 sec off in snooze mode, and off in alarm off mode
- Alarm indicator on in alarm on mode, off in alarm off mode
- In setting mode, hour digit advances by + 1 when HR switch is depressed
- In setting mode, minute digit advances by + 1 when MIN switch is depressed
- In setting mode, digit (hour or minute) advances automatically at 4 Hz rate by keeping HR switch or MIN switch depressed more than 2 seconds

(1) Mode Select

Alarm time is displayed while HR or MIN switch is depressed, setting mode is selected by depressing either NORS or ALS switch, alarm is selected by depressing

ALMOFF and SNZ switch, test mode is entered by TEST and TP pin.

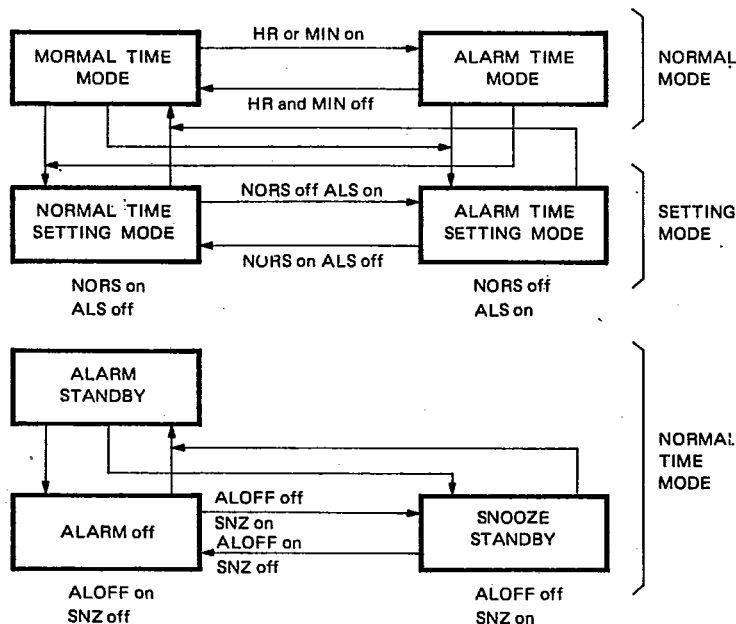

Timekeeping



**(2) Alarm Function**

Alarm buzzer sounds for 1 minute in either alarm standby or snooze standby mode when normal time corresponds to set alarm time when alarm sounds. A momentary closure of alstop, or changing any mode switches, will

stop the alarm buzzer sound.

Alarm function can be operated in all modes except alarm off mode.

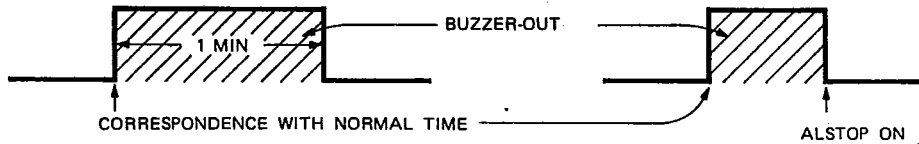

WAVEFORM OF ALARM SOUND  
4096 x 8 x 1 Hz

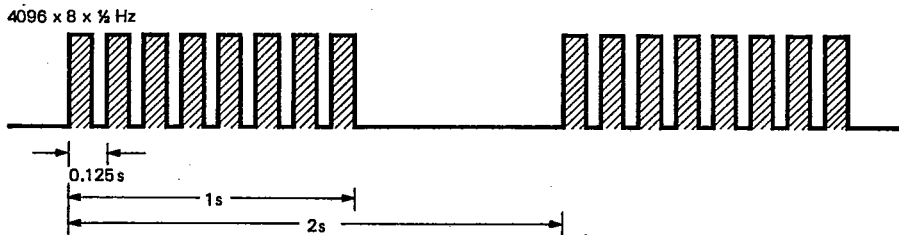
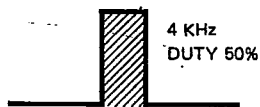
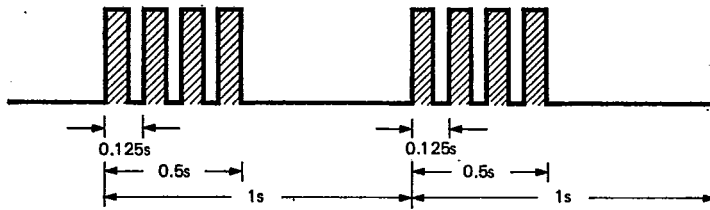

**(3) Snooze Function**

Snooze function can be operated in alarm time mode, alarm time setting mode, and normal time setting mode, when snooze standby mode is selected and normal time corresponds to alarm time, buzzer sound will be output and snooze indicator will flash at 1 Hz rate, 0.5 SEC. on 0.5 SEC off, and snooze function will operate.

start output 4 minutes later and will continue.

If alstop switch is not turned on while buzzer is sounding, buzzer sound will stop after 1 minute and snooze operation will be released and return to snooze standby mode.

If alstop switch is turned on while buzzer is sounding, alarm sound will be suspended once, but buzzer sound will

Snooze function can be also cancelled by changing any mode switches.

9325812 UNITED MICROELECTRONICS

92D 00702

D 7-49-15-02



UM3273

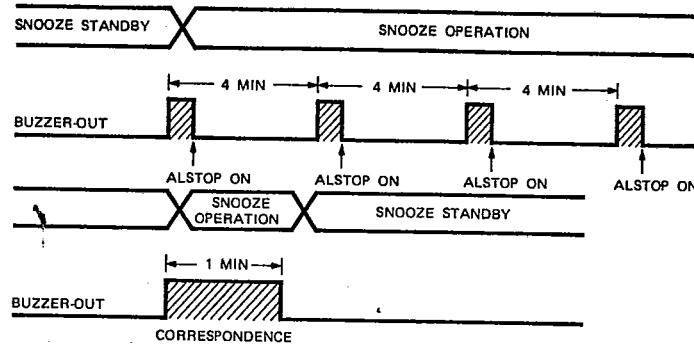

(4) Trigger Function

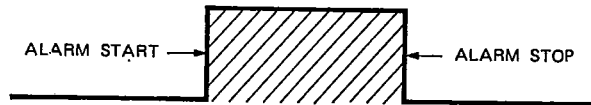

(5) LCD Layout

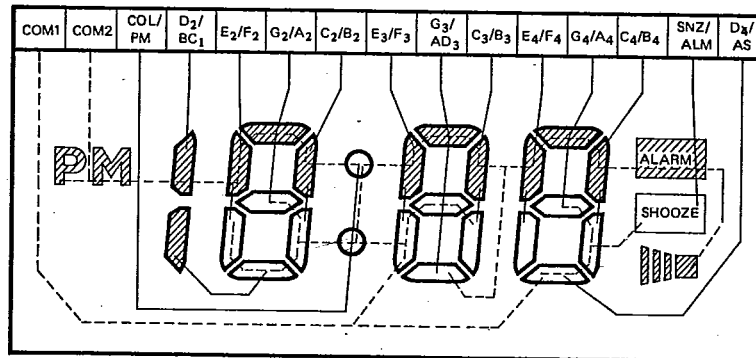

Display Format

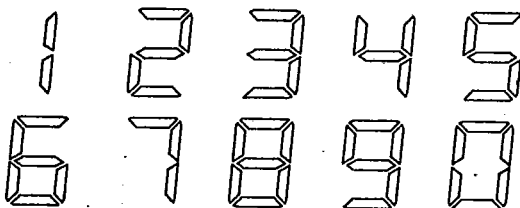

(6) Built-In Oscillator

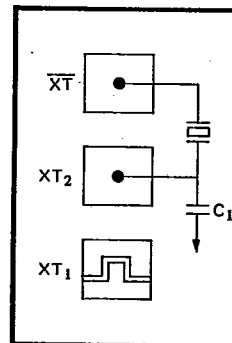

a) With Trimmer

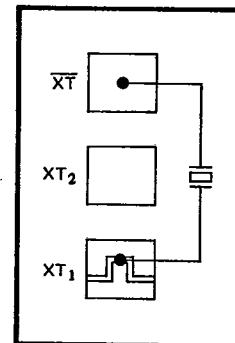

b) Without Trimmer



Operation Flow Chart

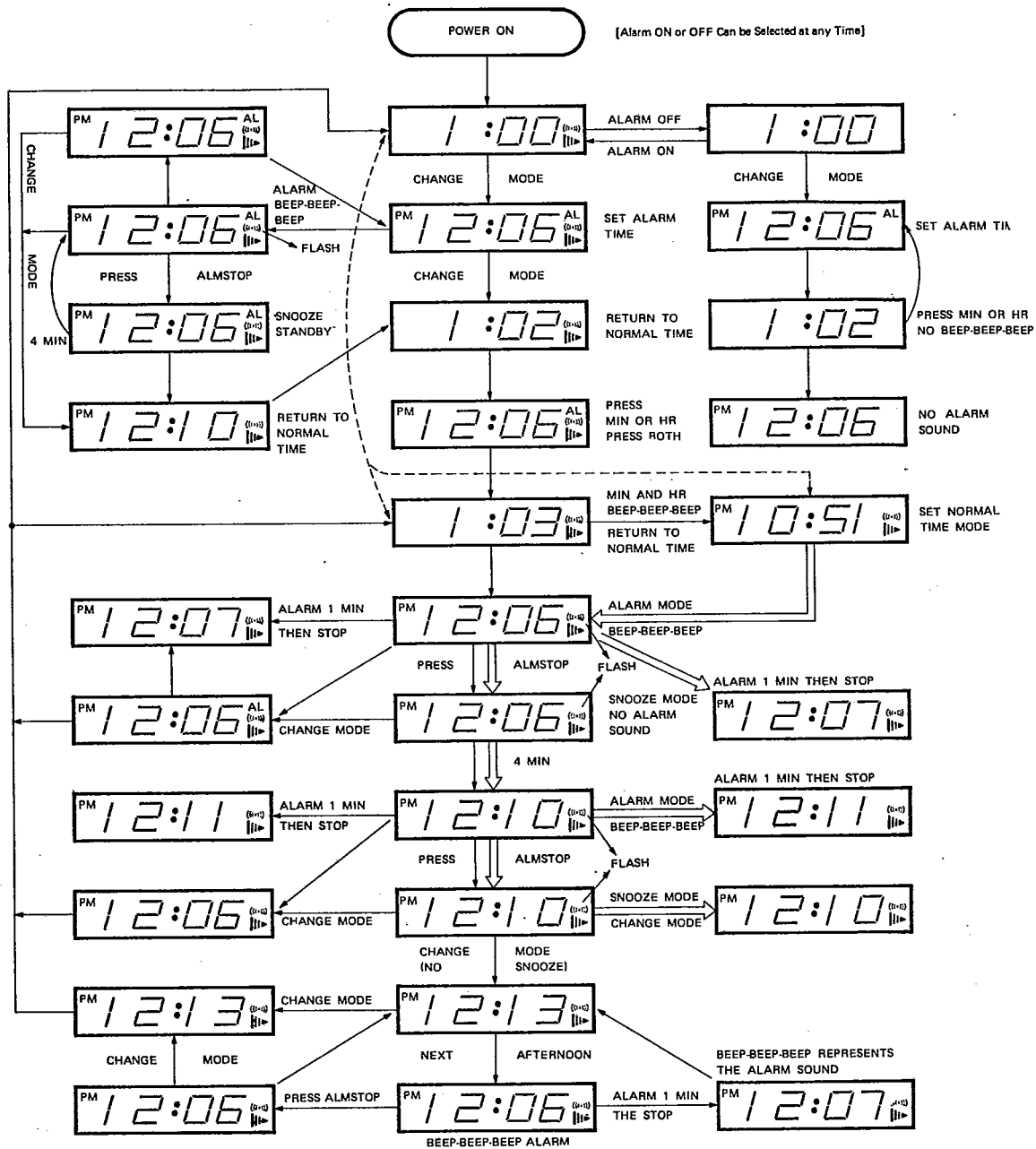

9325812 UNITED MICROELECTRONICS

92D 00704

D7-49-15-02



UM3273

Bonding Diagram

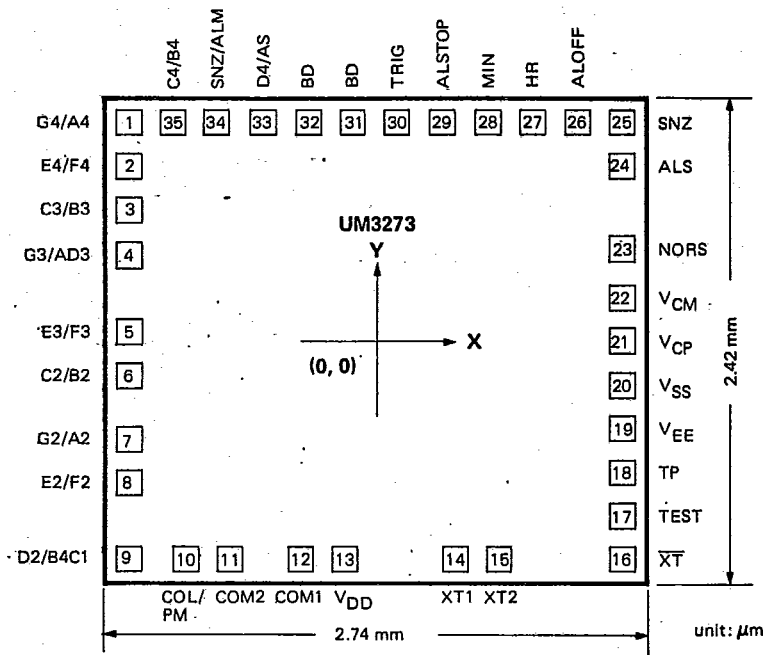

| Pad No. | Designation | X     | Y     | Pad No. | Designation | X     | Y    |
|---------|-------------|-------|-------|---------|-------------|-------|------|
| 1       | G4/A4       | -1204 | 1005  | 19      | VEE         | 1158  | -401 |
| 2       | E4/F4       | -1204 | 803   | 20      | VSS         | 1204  | -202 |
| 3       | C3/B3       | -1204 | 549   | 21      | VCP         | 1204  | -1   |
| 4       | G3/AD3      | -1204 | 349   | 22      | VCM         | 1204  | 199  |
| 5       | E3/F3       | -1204 | 27    | 23      | NORS        | 1204  | 398  |
| 6       | C2/B2       | -1204 | -73   | 24      | ALS         | 1204  | 687  |
| 7       | G2/A2       | -1201 | -491  | 25      | SNZ         | 1204  | 942  |
| 8       | E2/F2       | -1202 | -691  | 26      | ALOFF       | 980   | 955  |
| 9       | D2/BC1      | -1202 | -1011 | 27      | HR          | 752   | 975  |
| 10      | COL/PM      | -944  | -1011 | 28      | MIN         | 462   | 1012 |
| 11      | COM2        | -744  | -1012 | 29      | ALSTOP      | 244   | 1018 |
| 12      | COM1        | -416  | -1011 | 30      | TRIG        | -4    | 983  |
| 13      | VDD         | -277  | -1012 | 31      | BD          | -204  | 983  |
| 14      | XT1         | 316   | -1012 | 32      | BD          | -404  | 983  |
| 15      | XT2         | 502   | -1011 | 33      | D4/AS       | -604  | 1005 |
| 16      | XT          | 1204  | -1012 | 34      | SNZ/ALM     | -804  | 1005 |
| 17      | TEST        | 1204  | -801  | 35      | C4/B4       | -1004 | 1005 |
| 18      | TP          | 1204  | -601  |         |             |       |      |

Ordering Information

| Part No. | Items | Alarm Output    |                   | LCD Colon |        |
|----------|-------|-----------------|-------------------|-----------|--------|
|          |       | 2048 x 8 x 1 Hz | 2048 x 8 x 1/2 Hz | Flash     | Freeze |
| UM3273   |       | ✓               |                   | ✓         |        |
| UM3273-1 |       | ✓               |                   |           | ✓      |
| UM3273-2 |       |                 | ✓                 | ✓         |        |
| UM3273-3 |       |                 | ✓                 |           | ✓      |

Timekeeping

9325812 UNITED MICROELECTRONICS

92D 00705

DT-49-15-02-



UM3273

Typical Application Circuit

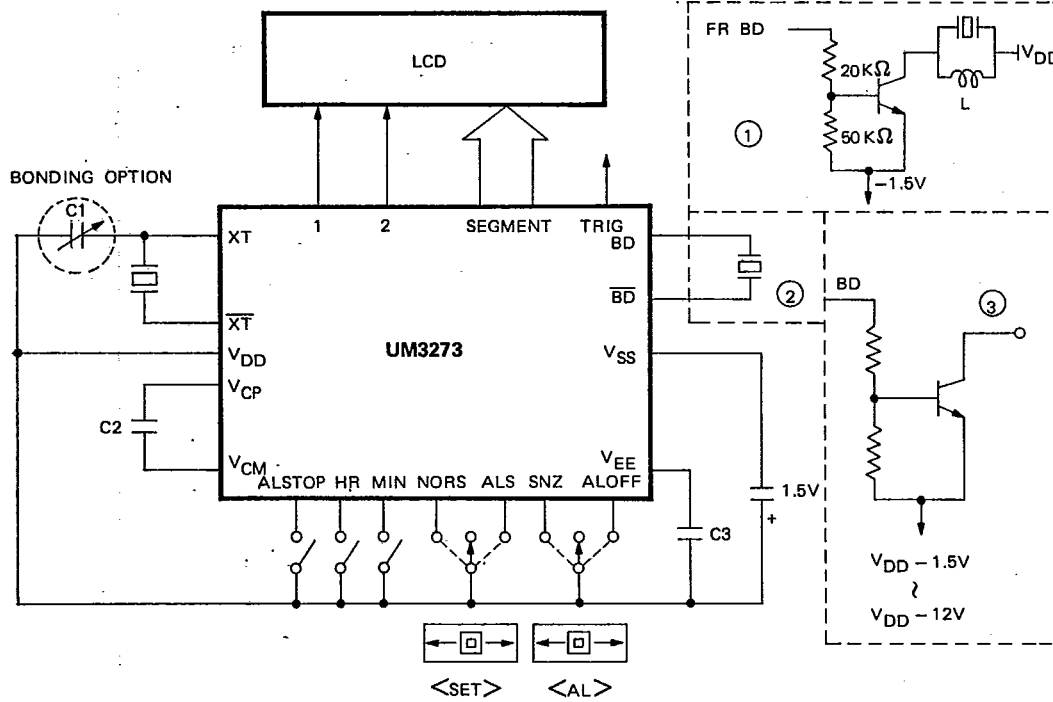

C1 = 5 ~ 35 PF

C2, C3 ~ 0.1μF

\*There is a bonding option capacitance (20 PF) that can replace C1.

There are three types of buzzer application circuits, as indicated by the areas boxed by dotted lines.