

Features

- 29.5 dB Gain at 900 MHz
- 33 dBm P1dB at 900 MHz
- 48 dBm Output IP3 at 900 MHz
- MTTF > 100 Years
- Two Power Supplies

Description

The ASX620, a power amplifier MMIC, has a high linearity, high gain, and high efficiency over a wide range of frequency, being suitable for use in both receiver and transmitter of telecommunication systems up to 3 GHz. The amplifier is available in an SOIC-8 package and passes through the stringent DC, RF, and reliability tests.



Package Style: SOIC-8

Typical Performance*

Parameters	Units	Typical
Frequency	MHz	900
Gain	dB	29.5
S11	dB	-15
S22	dB	-8
Output IP3 ¹⁾	dBm	48
Noise Figure	dB	6.7
Output P1dB	dBm	33
Current	mA	950
Device Voltage	V	5

* Performance tested at 50 Ω system and a room temperature.

1) OIP3 measured with two tones at an output power of +15 dBm/tone separated by 1 MHz.

Product Specifications*

Parameters	Units	Min	Typ	Max
Testing Frequency	MHz		900	
Gain	dB	28.5	29.5	
S11	dB		-15	
S22	dB		-8	
Output IP3	dBm	46	48	
Noise Figure	dB		6.7	7.0
Output P1dB	dBm	31	33	
Current	mA	900	950	1000
Device Voltage	V		5	

* 100% in-house DC & RF testing is done on packaged products before taping.

Absolute Maximum Ratings

Parameters	Rating
Operating Case Temperature	-40 to +85°C
Storage Temperature	-40 to +150°C
Device Voltage	+6 V
Operating Junction Temperature	+150°C
Input RF Power (CW, 50ohm matched)*	25 dBm

* Please find the max. input power data from http://www.asb.co.kr/pdf/Maximum_Input_Power_Analysis.pdf

Application Circuit

- 196 ~ 216 MHz
- CDMA
- GSM
- RFID(USA)

Pin Configuration

Pin No.	Function
1	2nd stage RF IN
2	1st stage RF OUT
3,5,8	GND
4	1st stage RF IN
6,7	2nd stage RF OUT

Outline Drawing

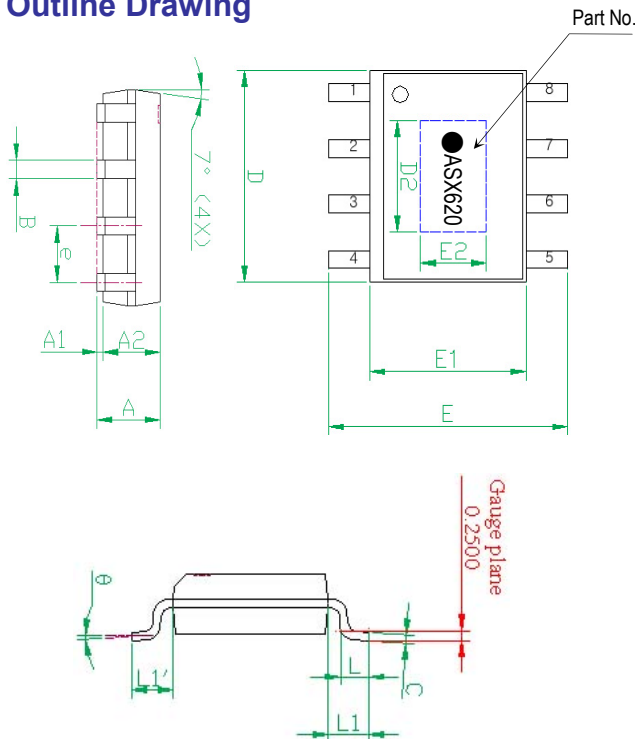

Symbols	Dimensions (In mm)		
	MIN	NOM	MAX
A	1.40	1.50	1.60
A1	0.00	---	0.10
A2	---	1.45	---
B	0.33	---	0.51
C	0.19	---	0.25
D	4.80	---	5.00
D2	3.20	3.30	3.40
E	5.80	6.00	6.20
E1	3.80	3.90	4.00
E2	2.30	2.40	2.50
e	---	1.27	---
L	0.40	---	1.27
y	---	---	0.10
θ	0°	---	8°
L1-L1'	---	---	0.12
L1	1.04REF		

Pin No.	Function	Pin No.	Function.
1	2nd stage RF IN	5	GND
2	1st stage RF OUT	6	2nd stage RF OUT
3	GND	7	2nd stage RF OUT
4	1st stage RF IN	8	GND

Note: 1. Backside metal paddle is RF and DC ground.

Mounting Recommendation (in mm)

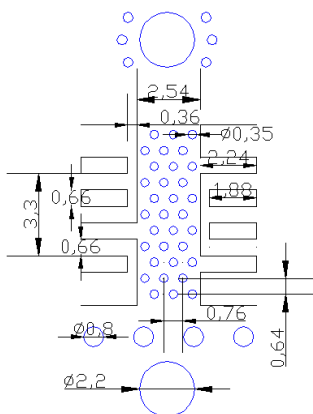

- Note:**
1. Add as much copper as possible to inner and outer layers near the part to ensure optimal thermal performance.
 2. To ensure reliable operation, device ground paddle-to-ground pad soldering is critical.
 3. Add mounting screws near the part to fasten the board to a heat sink. Ensure that the ground / thermal via region contacts the heat sink.
 4. A proper heat dissipation path underneath the area of the PCB for the mounted device is strictly required for proper thermal operation. Damage to the device can result from inappropriate heat dissipation.

ESD Classification

HBM	Class 1B
	Voltage Level: 500 V~1000 V
MM	Class A
	Voltage Level: <200 V

CAUTION: ESD-sensitive device!

Moisture Sensitivity Level (MSL)

Level 3 at 260°C reflow

APPLICATION CIRCUIT

196 ~ 216 MHz

+5 V

Frequency (MHz)	196	216
Magnitude S21 (dB)	38	38
Magnitude S11 (dB)	-13	-14
Magnitude S22 (dB)	-9	-9
Output P1dB (dBm)	33.0	32.5
Output IP3 ¹⁾ (dBm)	46.0	44.5
Noise Figure (dB)	6.7	6.7
Device Voltage (V)	5	5
Current (mA)	950	950

1) OIP3 is measured with two tones at an output power of +15 dBm/tone separated by 1 MHz.

Schematic

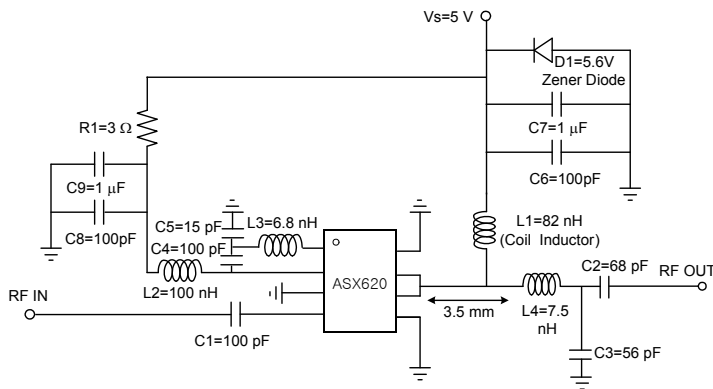

Board Layout (FR4, 40x40 mm², 0.8T)

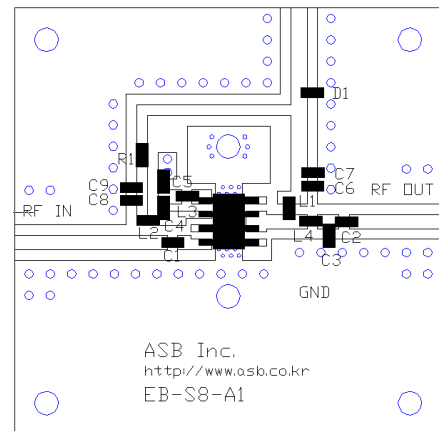

S-parameters & K-factor

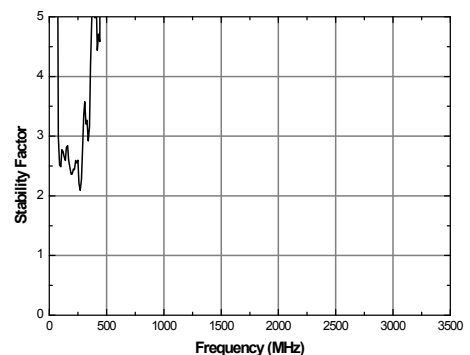
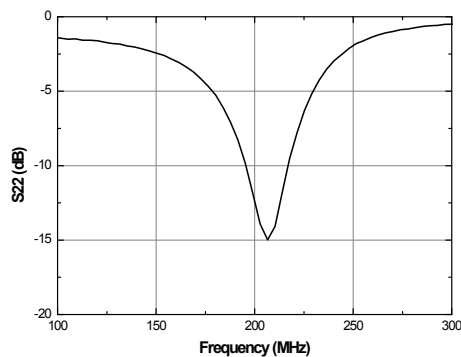
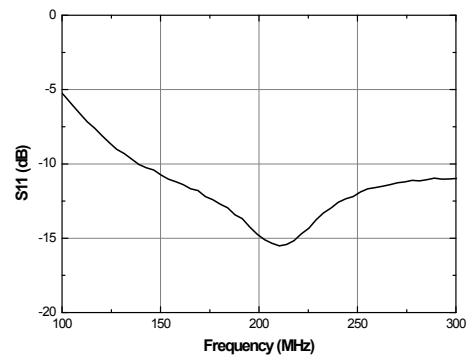
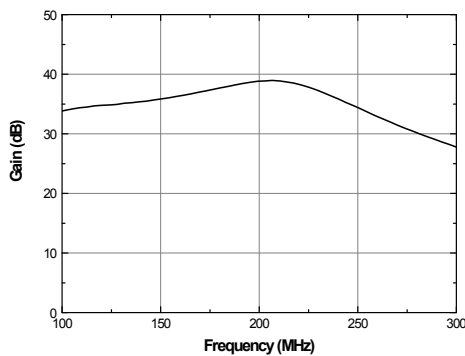

APPLICATION CIRCUIT

CDMA Rx
824 ~ 849 MHz
+5 V

Frequency (MHz)	824~849
Magnitude S21 (dB)	31.5
Magnitude S11 (dB)	-15
Magnitude S22 (dB)	-8
Output P1dB (dBm)	32.5
Output IP3 ¹⁾ (dBm)	48
Noise Figure (dB)	6.7
Device Voltage (V)	5
Current (mA)	950

1) OIP3 is measured with two tones at an output power of +15 dBm/tone separated by 1 MHz.

Schematic

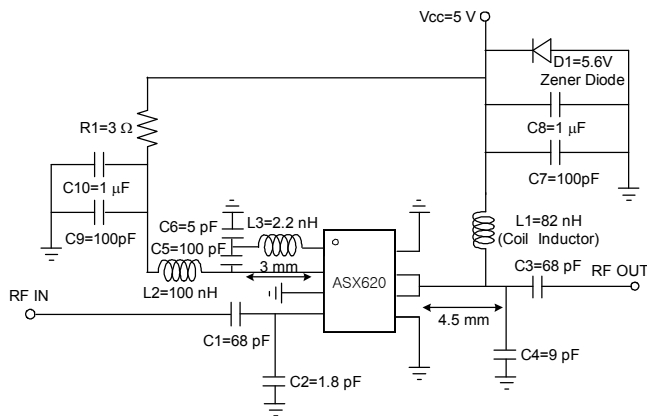

Board Layout (FR4, 40x40 mm², 0.8T)

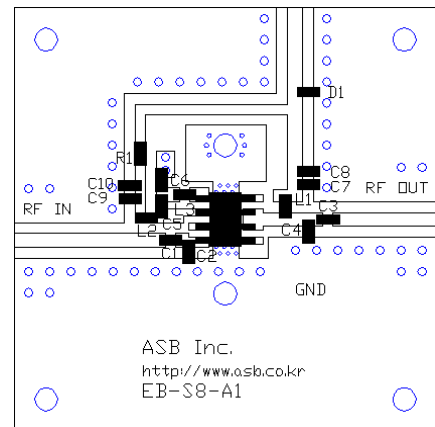

S-parameters & K-factor

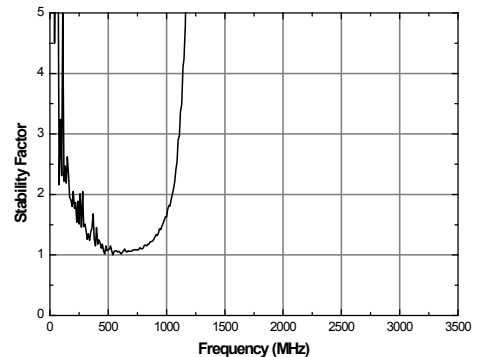
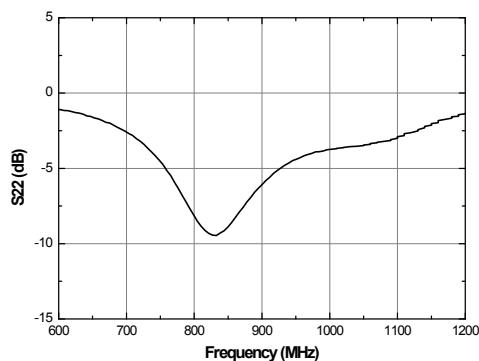
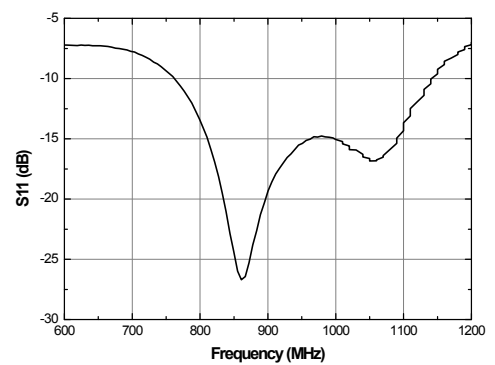
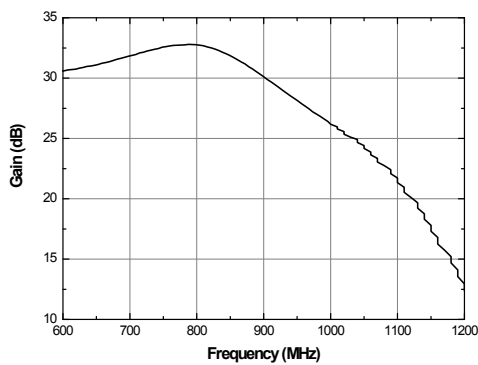

APPLICATION CIRCUIT

CDMA Tx, GSM Rx

869 ~ 915 MHz

+5 V

Frequency (MHz)	869~894	890~915
Magnitude S21 (dB)	30	29.5
Magnitude S11 (dB)	-15	-15
Magnitude S22 (dB)	-10	-8
Output P1dB (dBm)	33	33
Output IP3 ¹⁾ (dBm)	48	48
Noise Figure (dB)	7.5	6.7
Device Voltage (V)	5	5
Current (mA)	950	950

1) OIP3 is measured with two tones at an output power of +15 dBm/tone separated by 1 MHz.

Schematic

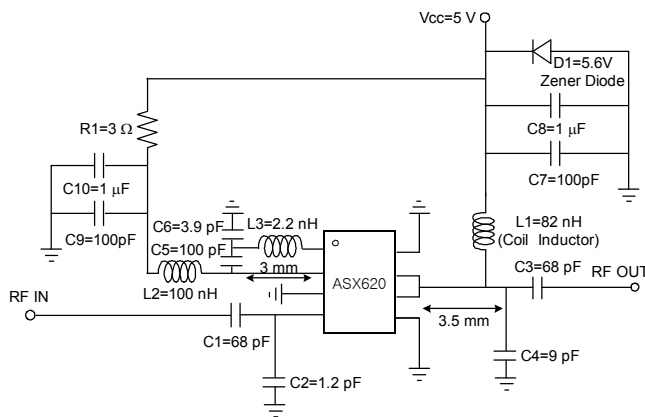

Board Layout (FR4, 40x40 mm², 0.8T)

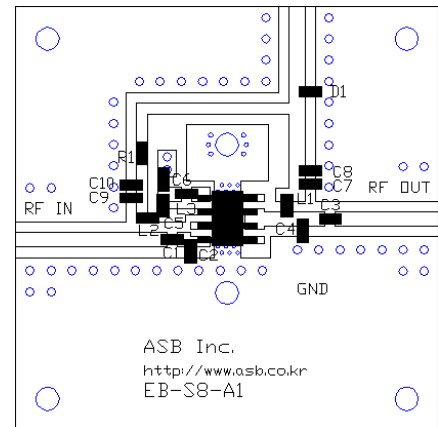

S-parameters & K-factor

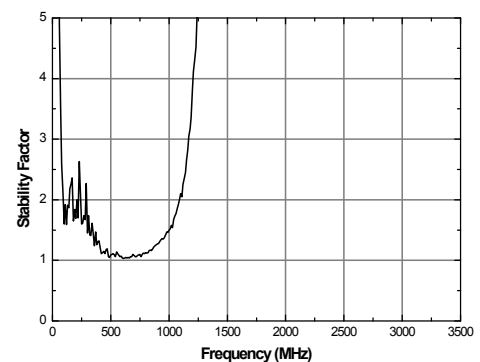
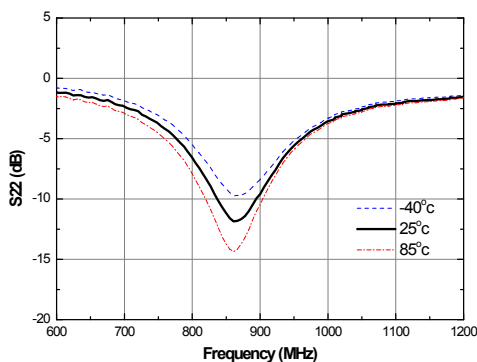
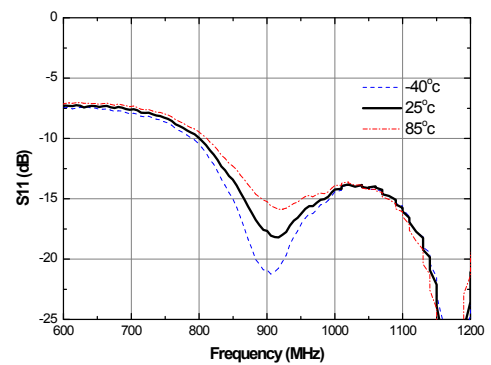
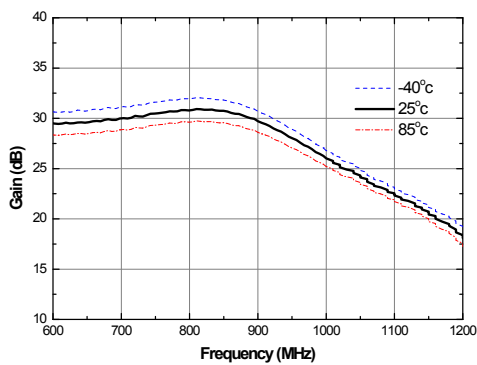

Current vs. Temperature

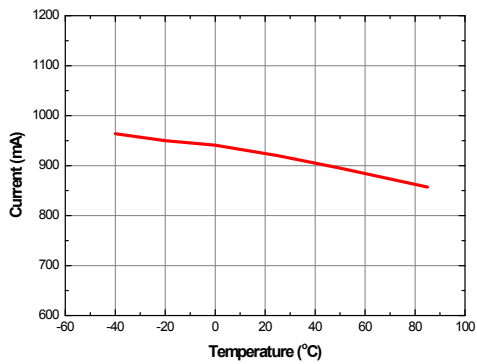

Gain vs. Temperature

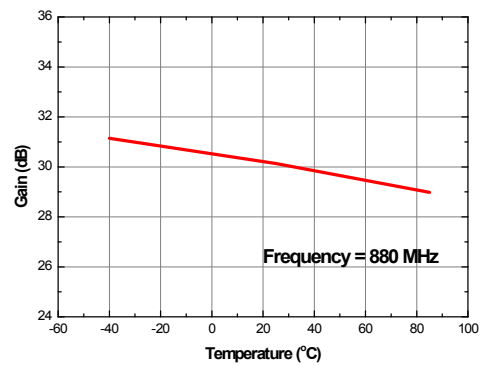

P1dB vs. Temperature

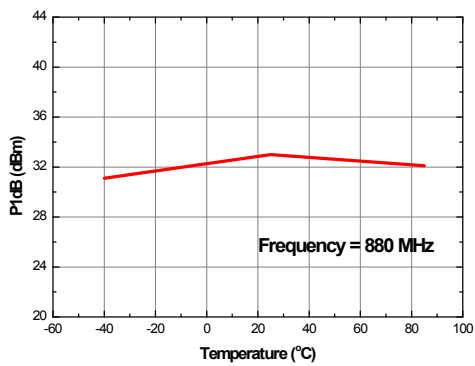

Output IP3 vs. Tone Power (Frequency = 880 MHz)

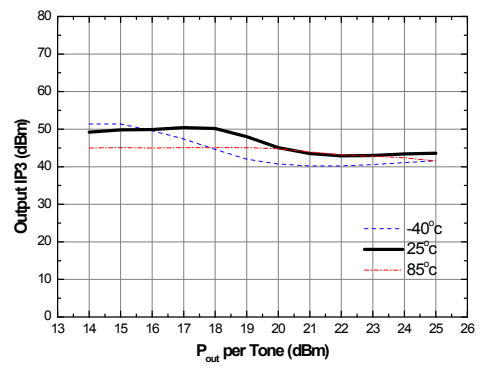

APPLICATION CIRCUIT

GSM Tx

935 ~ 960 MHz

+5 V

Frequency (MHz)	935~960
Magnitude S21 (dB)	29
Magnitude S11 (dB)	-15
Magnitude S22 (dB)	-8
Output P1dB (dBm)	33
Output IP3 ¹⁾ (dBm)	48
Noise Figure (dB)	6.8
Device Voltage (V)	5
Current (mA)	950

1) OIP3 is measured with two tones at an output power of +15 dBm/tone separated by 1 MHz.

Schematic

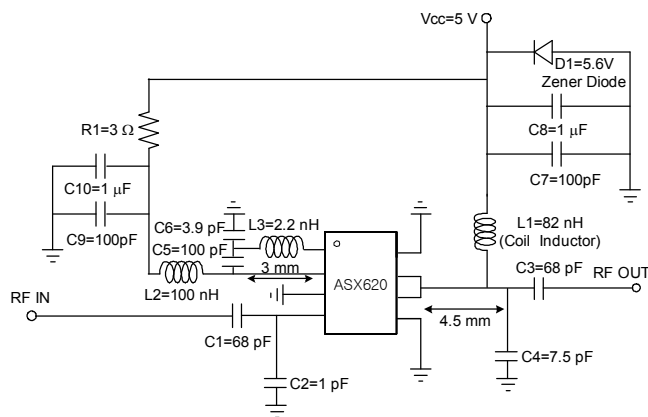

Board Layout (FR4, 40x40 mm², 0.8T)

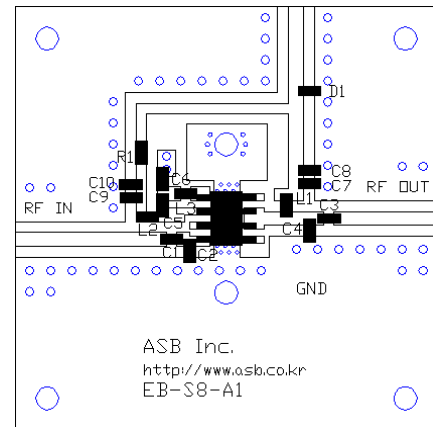

S-parameters & K-factor

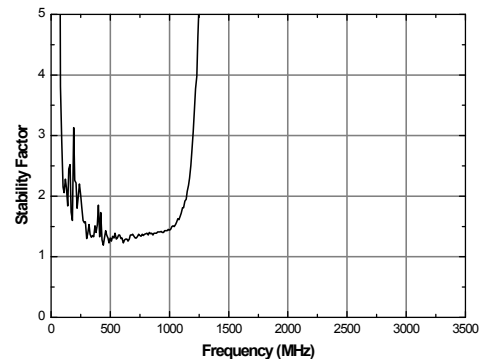
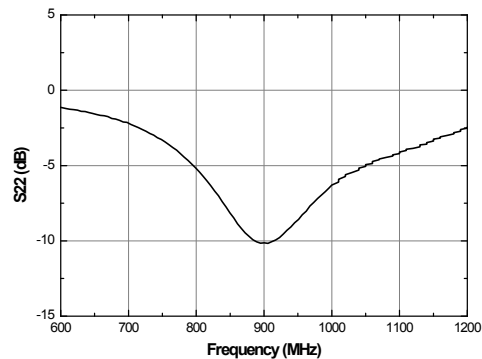
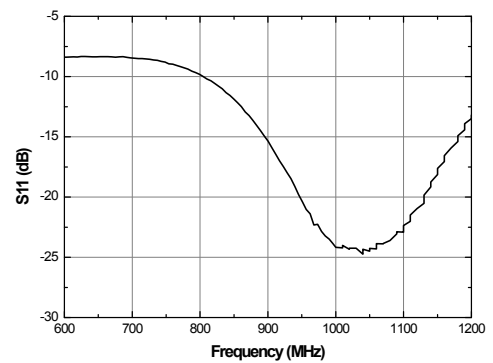
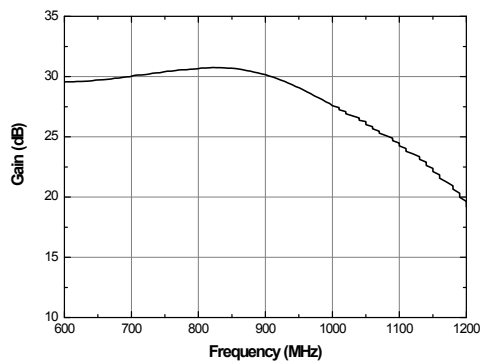

APPLICATION CIRCUIT

RFID(USA)
902 ~ 928 MHz
+5 V

Country	EU ²⁾	USA	Korea ²⁾	Japan ²⁾
Frequency (MHz)	865.6~867.6	902~928	910~914	950~956
Magnitude S21 (dB)	30.5	29	29.5	29
Magnitude S11 (dB)	-15	-15	-15	-15
Magnitude S22 (dB)	-12	-7.5	-8	-8
Output P1dB (dBm)	33	33	33	33
Output IP3 ¹⁾ (dBm)	47.5	48	48	48
Noise Figure (dB)	7.0	6.9	6.7	6.8
Device Voltage (V)	5	5	5	5
Current (mA)	950	950	950	950

1) OIP3 is measured with two tones at an output power of +15 dBm/tone separated by 1 MHz.
 2) Test Results are measured by CDMA Tx(EU), GSM Rx(Korea), GSM Tx(Japan) Application circuits.

Schematic

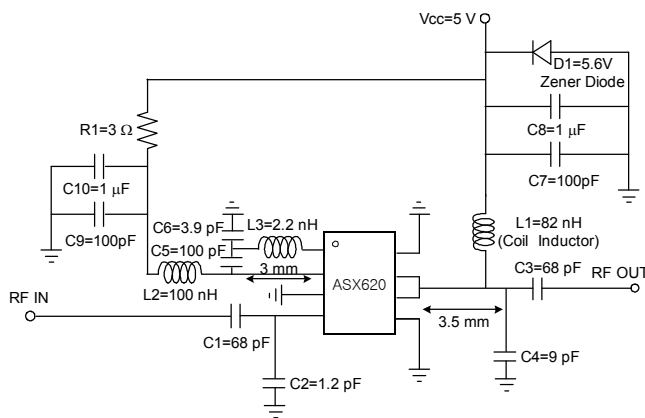

Board Layout (FR4, 40x40 mm², 0.8T)

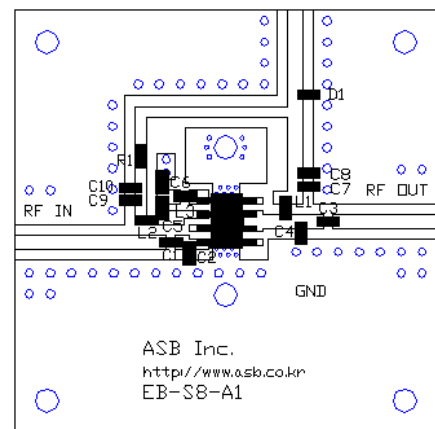

S-parameters & K-factor

