

Data Sheet

Features

- For Wireless LAN applications
- Usable bandwidth 9 MHz
- High attenuation
- Single-ended operation
- Ceramic Surface Mount Package (SMP)
- Hermetic
- RoHS compliant (2002/95/EC), Pb-free 

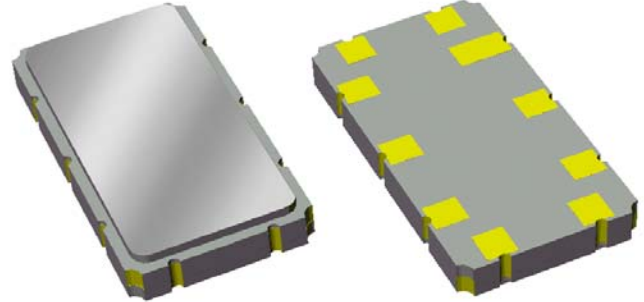

Package

Surface Mount 9.10 x 4.80 x 1.24 mm

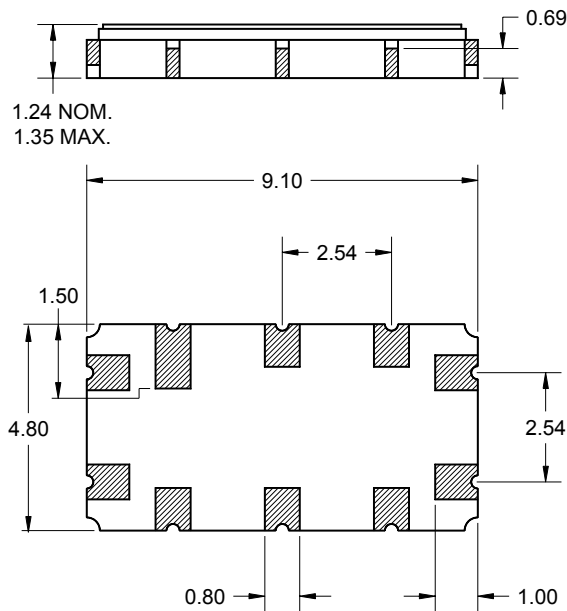

Dimensions shown are nominal in millimeters
 All tolerances are ± 0.15 mm except overall
 length and width $+0.10$ mm/ -0.10 mm

Body: Al_2O_3 ceramic
 Lid: Kovar, Ni plated
 Terminations: Au plating 0.5 - 1.0 μ m,
 over a 2 - 6 μ m Ni plating

Pin Configuration

Bottom View

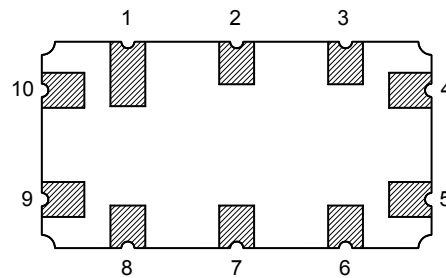

Pin No.	Description
4	RF Output
9	RF Input
1,2,3,5	Case Ground
6,7,8,10	Case Ground

Data Sheet

Electrical Specifications ⁽¹⁾

Operating Temperature Range: ⁽²⁾ -40 to +85 °C

Parameter ⁽³⁾	Minimum	Typical	Maximum	Unit
Center Frequency ⁽⁴⁾	969.20	970.06	970.80	MHz
Maximum Insertion Loss at 970 MHz	-	24	27	dB
Lower 3 dB Bandedge ⁽⁵⁾	-	964.4	965.5	MHz
Upper 3 dB Bandedge	974.5	975.3	-	MHz
Lower 35 dB Bandedge ⁽⁵⁾	961.5	963.0	-	MHz
Upper 35 dB Bandedge	-	977.4	978.5	MHz
Passband Ripple (over 3 dB bandwidth)	-	0.41	1.0	dB p-p
Passband Ripple (over any 300 kHz bandwidth)	-	0.23	0.3	dB p-p
Passband Amplitude Tilt	-	0.22	1.0	dB
Phase Ripple (over 3 dB bandwidth)	-	4.3	8.0	deg
Phase Ripple (over any 300 kHz bandwidth)	-	0.5	3.0	deg
Group Delay	-	0.84	1.0	µsec
Group Delay Variation (over 3 dB bandwidth)	-	34	130	nsec
Relative Attenuation ⁽⁵⁾				
10 - 945 MHz	35	40	-	dB
995 - 1400 MHz	35	40	-	dB
Adjacent Channel Rejection (Integrated Power) ⁽⁵⁾				
955.8 - 964.2 MHz	10	18	-	dB
975.8 - 984.2 MHz	10	18	-	dB
Optimal Source Impedance ⁽⁶⁾	-	50	-	Ω
Optimal Load Impedance ⁽⁶⁾	-	50	-	Ω

Notes:

1. All specifications are based on the test circuit shown below
2. In production, devices will be tested at room temperature to a guardbanded specification to ensure electrical compliance over temperature
3. Electrical margin has been built into the design to account for the variations due to temperature drift and manufacturing tolerances
4. Evaluated as the mean of the 3dB frequencies relative to minimum insertion loss
5. Referenced to minimum insertion loss
6. This is the optimum impedance in order to achieve the performance shown

Test Circuit:

Actual matching values may vary due to PCB layout and parasitics

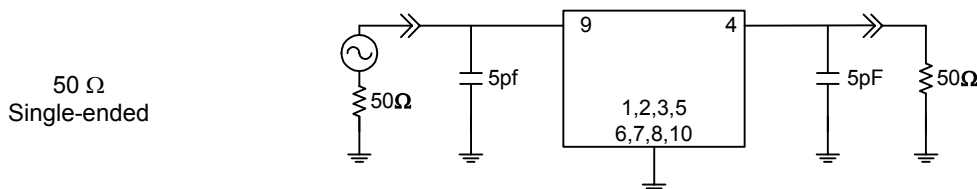

Data Sheet

Typical Performance (at +25°C)

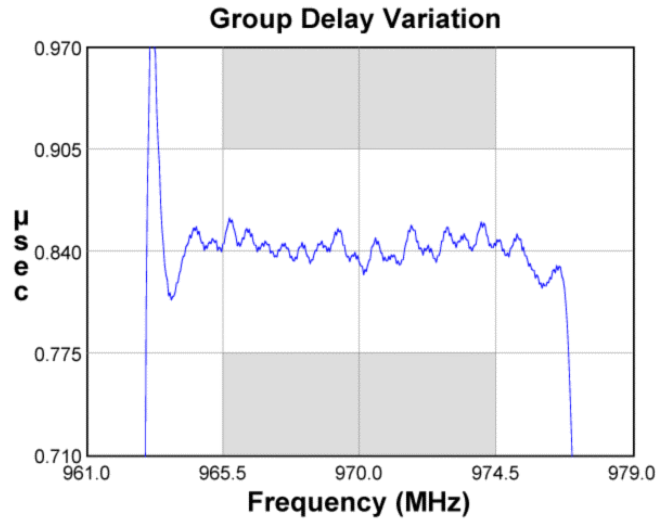
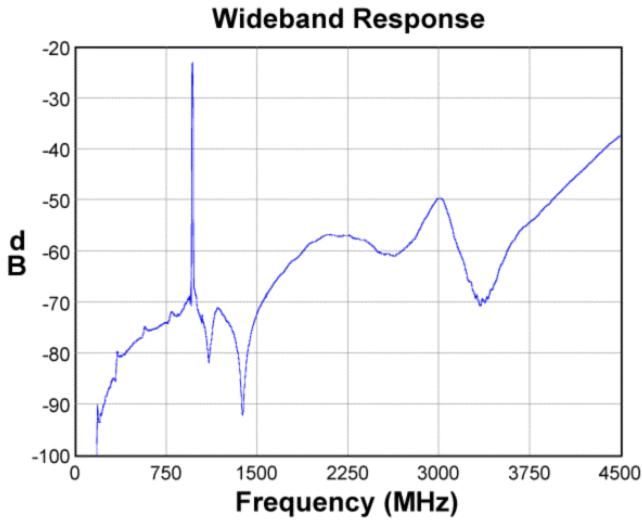
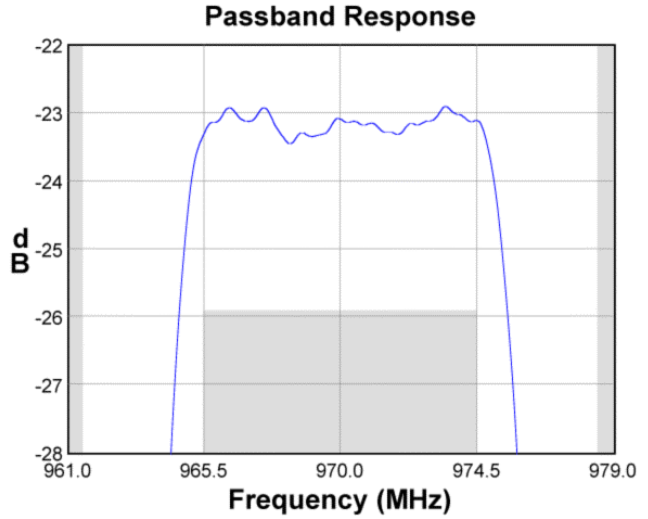
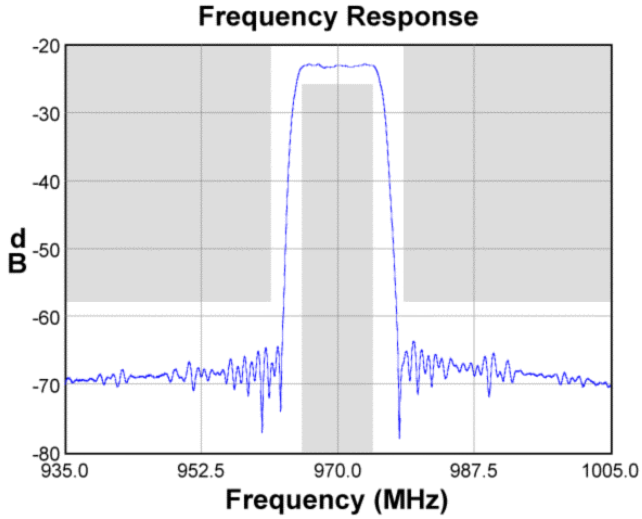

Input Smith Chart

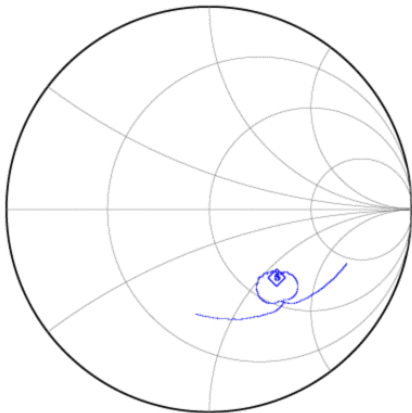

Output Smith Chart

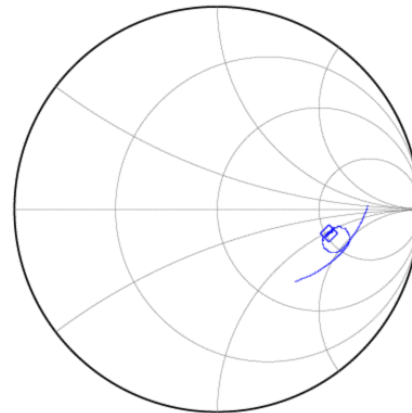

Data Sheet

Matching Schematics

Actual matching values may vary due to PCB layout and parasitics

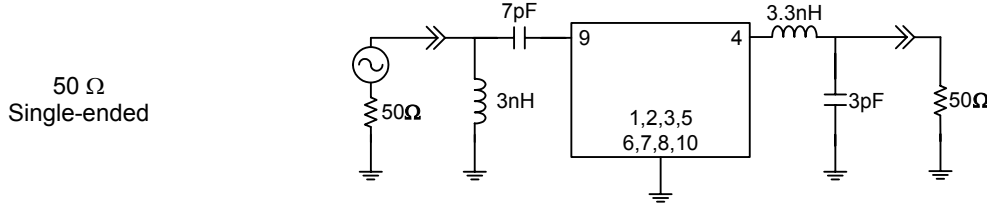

Marking

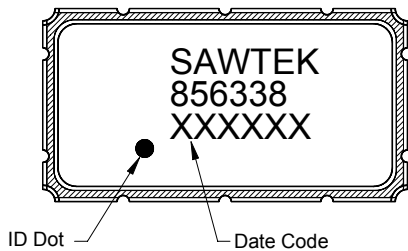

The date code consists of: day of the current year (Julian, 3 digits), last digit of the year (1 digit) and hour (2 digits)

PCB Footprint

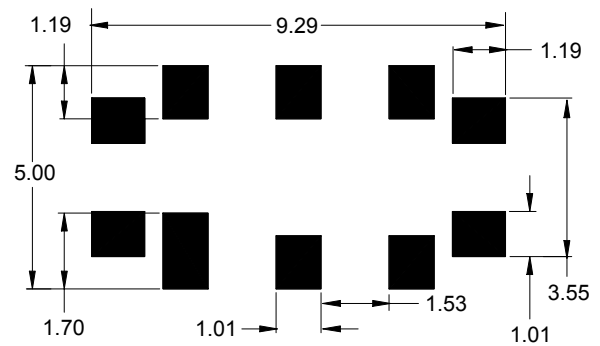

This footprint represents a recommendation only
Dimensions shown are nominal in millimeters

Tape and Reel

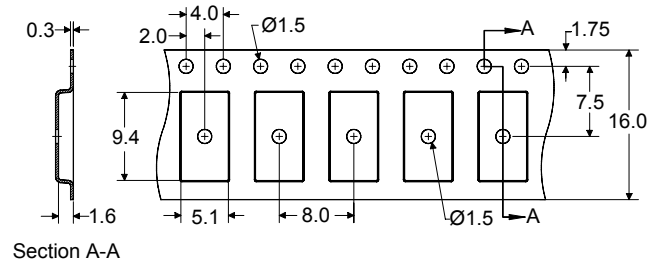
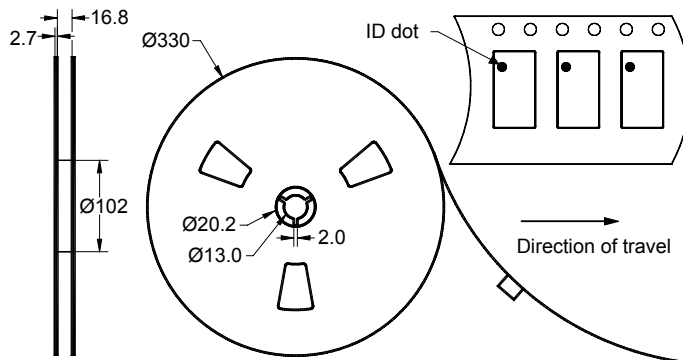

Dimensions shown are nominal in millimeters
Packaging quantity: 4000 units/reel

Data Sheet

Maximum Ratings

Parameter	Symbol	Minimum	Maximum	Unit
Operating Temperature Range	T	-40	+85	°C
Storage Temperature Range	T _{stg}	-55	+85	°C

Important Notes

Warnings

- Electrostatic Sensitive Device (ESD) 
- Avoid ultrasonic exposure

RoHS Compliance

- This product complies with EU directive 2002/95/EC (RoHS) 

Solderability

- Compatible with JEDEC J-STD-020C **Pb**-free process, **260°C** peak reflow temperature ([see soldering profile](#))

Links to Additional Technical Information

[PCB Layout Tips](#)

[Qualification Flowchart](#)

[Soldering Profile](#)

[S-Parameters](#)

[RoHS information](#)

[Other Technical Information](#)

Sawtek's liability is limited only to the Surface Acoustic Wave (SAW) component(s) described in this data sheet. Sawtek does not accept any liability for applications, processes, circuits or assemblies, which are implemented using any Sawtek component described in this data sheet.

Contact Information



PO Box 609501
 Orlando, FL 32860-9501
 USA

Phone: +1 (407) 886-8860
 Fax: +1 (407) 886-7061
 Email: custservice@sawtek.com
 Web: www.sawtek.com

Or contact one of our worldwide
 Network of [sales offices](#),
[representatives or distributors](#)