

**PLEASE CHECK WWW.MOLEX.COM FOR LATEST PART INFORMATION**

**Part Number:** **0191640309**  
**Status:** **Active**  
**Description:** Perma-Seal™ Ring Tongue Terminal for 14-16 AWG Wire, Stud Size 5/16, Mylar Tape Carrier

**Documents:**

[Drawing \(PDF\)](#) [RoHS Certificate of Compliance \(PDF\)](#)

**Agency Certification**

CSA LR18689  
 UL E32244

**General**

Product Family Ring and Spade Terminals  
 Series 19164  
 Crimp Quality Equipment Yes  
 Mil-Spec N/A  
 Product Name Perma-Seal™  
 Type Ring

**Physical**

Barrel Type Closed  
 Flammability 94V-2  
 Insulation NiAc™  
 Material - Plating Mating Tin  
 Packaging Type Adhesive Tape on Reel  
 Stud Size 5/16" (M8)  
 Wire Insulation Diameter 5.97mm (.235")  
 Wire Size AWG 14, 16  
 Wire Size mm² 1.23 - 1.94

**Material Info**

Old Part Number SB-225-56T

**Reference - Drawing Numbers**

Sales Drawing SD-19164-026

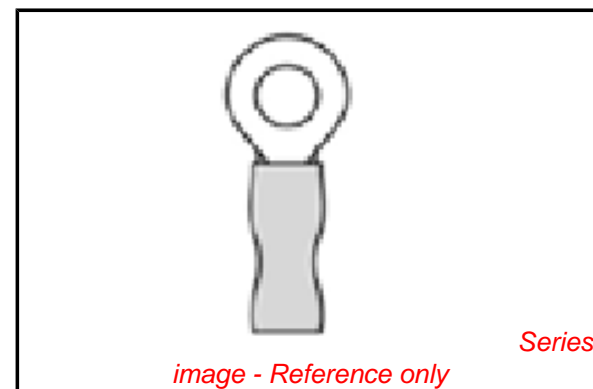

*image - Reference only*

**EU RoHS**

**ELV and RoHS Compliant**  
**REACH SVHC**  
 Not Reviewed  
**Halogen-Free Status**  
**Not Reviewed**

**China RoHS**



**Need more information on product environmental compliance?**

Email [productcompliance@molex.com](mailto:productcompliance@molex.com)  
 For a multiple part number RoHS Certificate of Compliance, [click here](#)

Please visit the [Contact Us](#) section for any non-product compliance questions.

**Search Parts in this Series**

[19164Series](#)

**Application Tooling | [FAQ](#)**

*Tooling specifications and manuals are found by selecting the products below. Crimp Height Specifications are then contained in the Application Tooling Specification document.*

**Global**

Description	Product #
Power Crimp Tool Head for Prema-Seal™ Terminals 10-22 AWG	<a href="#">0640057400</a>
ATP Perishable Tool Kit Used in ATP Presses that Process Product on Tape	<a href="#">0198082012</a>
Hand Crimp Tool, UL Approved	<a href="#">0640017400</a>

**PLEASE CHECK [WWW.MOLEX.COM](http://WWW.MOLEX.COM) FOR LATEST PART INFORMATION**

	13	12	11	10	9	8	7	6	5	4	3	2	1
	MATERIAL NUMBER	ENGINEERING NUMBER	MATERIAL NUMBER ON TAPE	ENGINEERING NUMBER ON TAPE	STUD SIZE	"S" ±.005/0.03	"D" MAX	"H" ±.010/0.25	"L" MAX	ID MIN			
J	191640031	SB-237-04	191640941	SB-237-04T	#4	.119/3.02	.320/8.17	.527/13.39	1.45/36.8	.082/2.08			
	191640032	SB-237-06	191640310	SB-237-06T	#6	.146/3.71	.320/8.17	.527/13.39	1.45/36.8	.082/2.08			
	191640033	SB-237-08	191640311	SB-237-08T	#8	.173/4.39	.320/8.17	.527/13.39	1.45/36.8	.082/2.08			
	191640034	SB-237-10	191640312	SB-237-10T	#10	.198/5.03	.320/8.17	.527/13.39	1.45/36.8	.082/2.08			
I	191640025	SB-225-10	191640940	SB-225-10T	#10	.198/5.03	.475/12.07	.338/8.59	1.63/41.4	.153/3.89			
	191640026	SB-225-14	191640308	SB-225-14T	1/4	.265/6.73	.475/12.07	.338/8.59	1.63/41.4	.153/3.89			
	191640027	SB-225-56	191640309	SB-225-56T	5/16	.328/8.33	.475/12.07	.338/8.59	1.63/41.4	.153/3.89			
	191640020	SB-218-38	191640307	SB-218-38T	3/8	.390/9.91	.475/12.07	.340/8.64	1.63/41.4	.153/3.89			

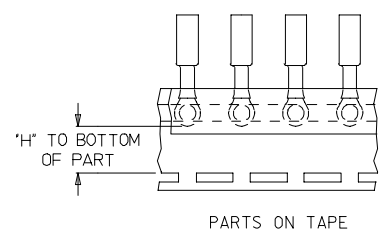
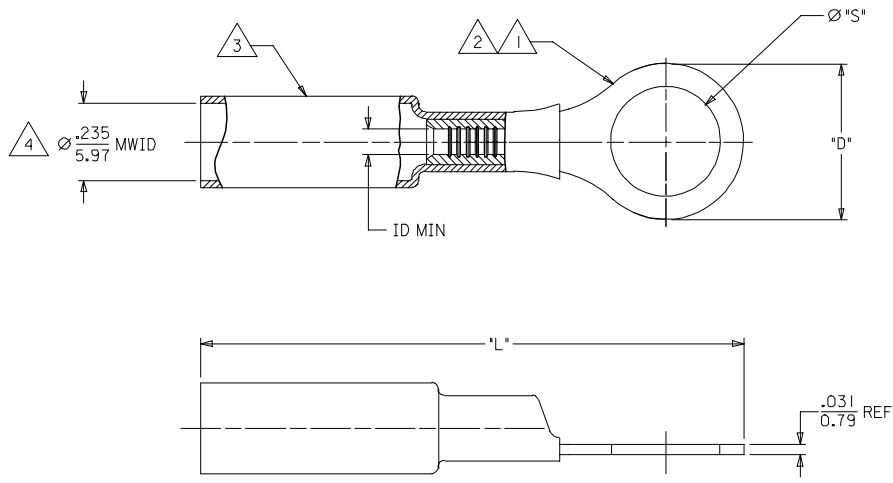

NOTE:

- 1. TERMINAL MATERIAL: COPPER ALLOY
- 2. FINISH: ELECTRO TIN PLATE.
- 3. INSULATION MATERIAL: HEAT SHRINKABLE TUBING WITH HOTMELT ADHESIVE INNER LINER. COLOR: BLUE
- 4. MWID = MAXIMUM WIRE INSULATION DIAMETER.

# SALES DRAWING

<b>REVISED TITLE BLOCK</b> EC NO: ETC2006-0017 DRW: SHADECK 2005/07/25 CHK: RDEROSS 2005/07/26 APPR: RDEROSS 2005/07/27 REVISIONS DESCRIPTION	QUALITY SYMBOLS	GENERAL TOLERANCES (UNLESS SPECIFIED)	DIMENSION STYLE	SCALE	DESIGN UNITS	THIRD ANGLE PROJECTION															
	$\nabla=0$ $\nabla=0$	<table border="1"> <thead> <tr> <th></th> <th>mm</th> <th>INCH</th> </tr> </thead> <tbody> <tr> <td>4 PLACES</td> <td>± ---</td> <td>± ---</td> </tr> <tr> <td>3 PLACES</td> <td>± ---</td> <td>± ---</td> </tr> <tr> <td>2 PLACES</td> <td>± ---</td> <td>± ---</td> </tr> <tr> <td>1 PLACE</td> <td>± ---</td> <td>± ---</td> </tr> </tbody> </table>		mm	INCH	4 PLACES	± ---	± ---	3 PLACES	± ---	± ---	2 PLACES	± ---	± ---	1 PLACE	± ---	± ---	IN/MM	---	INCH	
		mm	INCH																		
	4 PLACES	± ---	± ---																		
3 PLACES	± ---	± ---																			
2 PLACES	± ---	± ---																			
1 PLACE	± ---	± ---																			
		DRAWN BY: BENDERLE CHECKED BY: HBEITZEL APPROVED BY: RDEROSS MATERIAL NO.	DATE: 2002/08/26 DATE: 2002/08/26 DATE: 2002/08/26	TITLE: RING TONGUE TERMINAL PERMA-SEAL NIAC 16-14 AWG MOLEX INCORPORATED	SHEET NO. 1 OF 1																
		DRAFT WHERE APPLICABLE MUST REMAIN WITHIN DIMENSIONS	SEE CHART		SD-19164-026																