

FEATURES

Evaluation Board featuring the ADF4208 synthesizer.
 Requires only RF and IF VCO's and Loop Filters for dual PLL.
 Complete with SMA connectors, battery, and on board 10MHz Crystal.
 Programmable via a serial interface.
 Accompanying Software allows complete control of synthesizer functions from PC using Windows 95/98/NT
 Battery Operated: Choice of 3V or 5V supplies
 On Board Monitoring of Current and Voltage.

GENERAL DESCRIPTION

This board is designed to allow the user to evaluate the performance of the ADF4208 Dual Frequency Synthesizer for PLL's (Phase Locked Loops). The block diagram of the board is shown below. It contains the ADF4208 synthesizer, a pc connector, and SMA connections for reference input, power supplies and RF and IF output. The board only requires an RF VCO and loop filter and an IF VCO and loop filter. A cable is included with the board to connect to a pc printer port.

The package also contains windows software to allow easy programming of the synthesizer.

BLOCK DIAGRAM

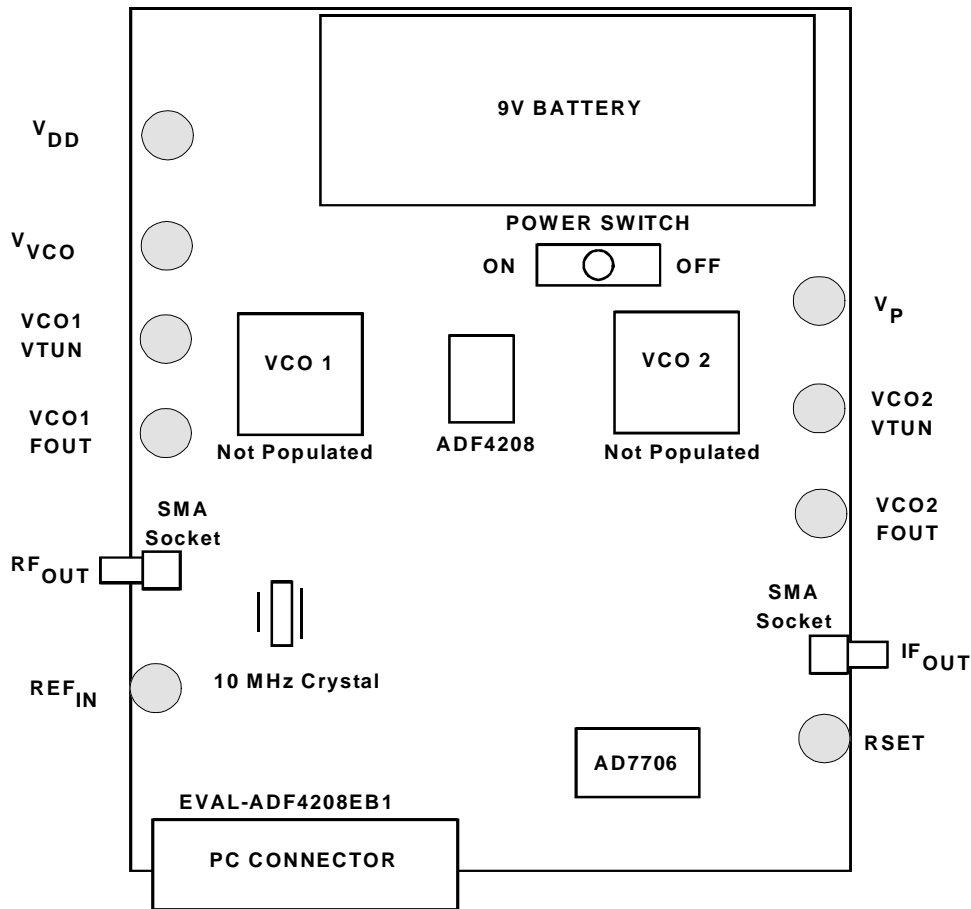

REV.PrA 02/00

© Analog Devices, Inc., 1999

Information furnished by Analog Devices is believed to be accurate and reliable. However, no responsibility is assumed by Analog Devices for its use, nor for any infringements of patents or other rights of third parties which may result from its use. No license is granted by implication or otherwise under any patent or patent rights of Analog Devices.

One Technology Way, P.O. Box 9106, Norwood, MA 02062-9106, U.S.A.
 Tel: 781-329-4700 Fax: 781-326-8703

Hardware Description

The evaluation board comes with a cable for connecting to the printer port of a PC. The silk screen and cable diagram for the evaluation board are shown below. The board schematic is shown on pages 3 and 4.

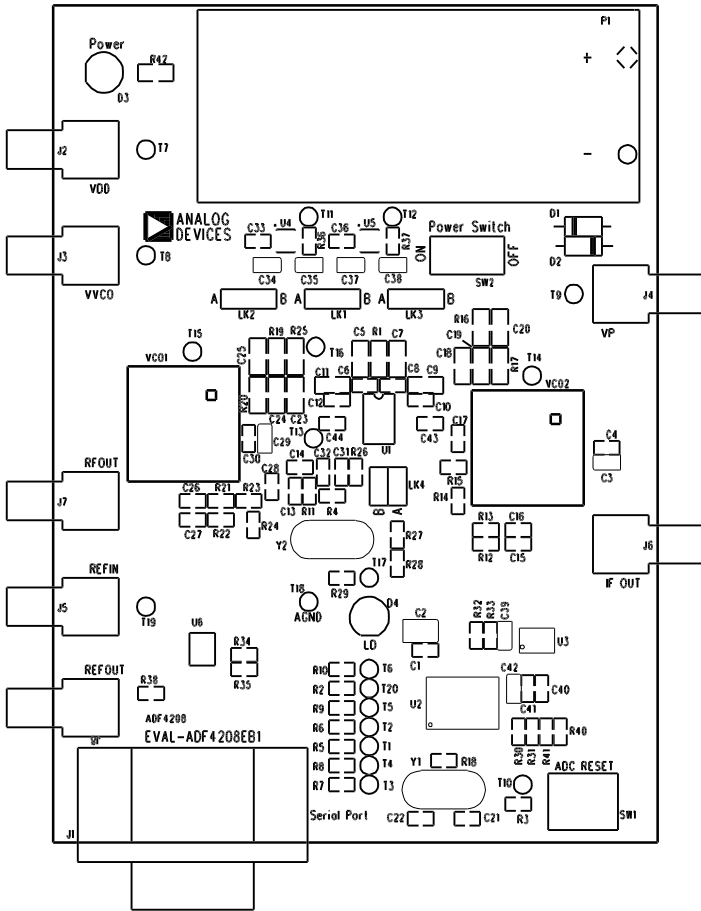

Figure 1. Evaluation Board Silkscreen

The board is powered from a single 9V battery. The power supply circuitry allows the user to choose either 3V or 5V for the ADF4208 V_{DD} and V_P , and for the VCO supply. The default settings are 3V for the ADF4208 V_{DD} and 5V for the ADF4208 V_P and for the VCO supply. **It is very important to note that the ADF4208 V_{DD} should never exceed the ADF4208 V_P . This can damage the device.**

All components necessary for LO generation are catered for on-board. The crystal oscillator circuit provides the necessary 10MHz reference frequency. The addition of an SMA connector allows an external reference to be used (Please consult circuit diagram to see what components are needed to be added or removed for this). The PLL requires a loop filter and VCO for both the IF and RF sides to complete the dual PLL. The output is available at RF OUT and IF OUT through standard SMA

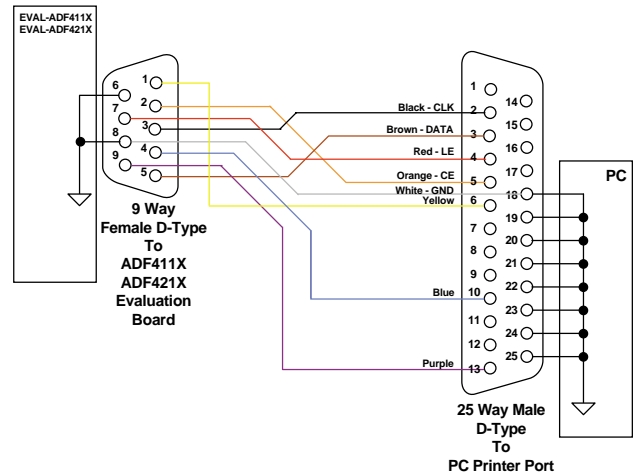
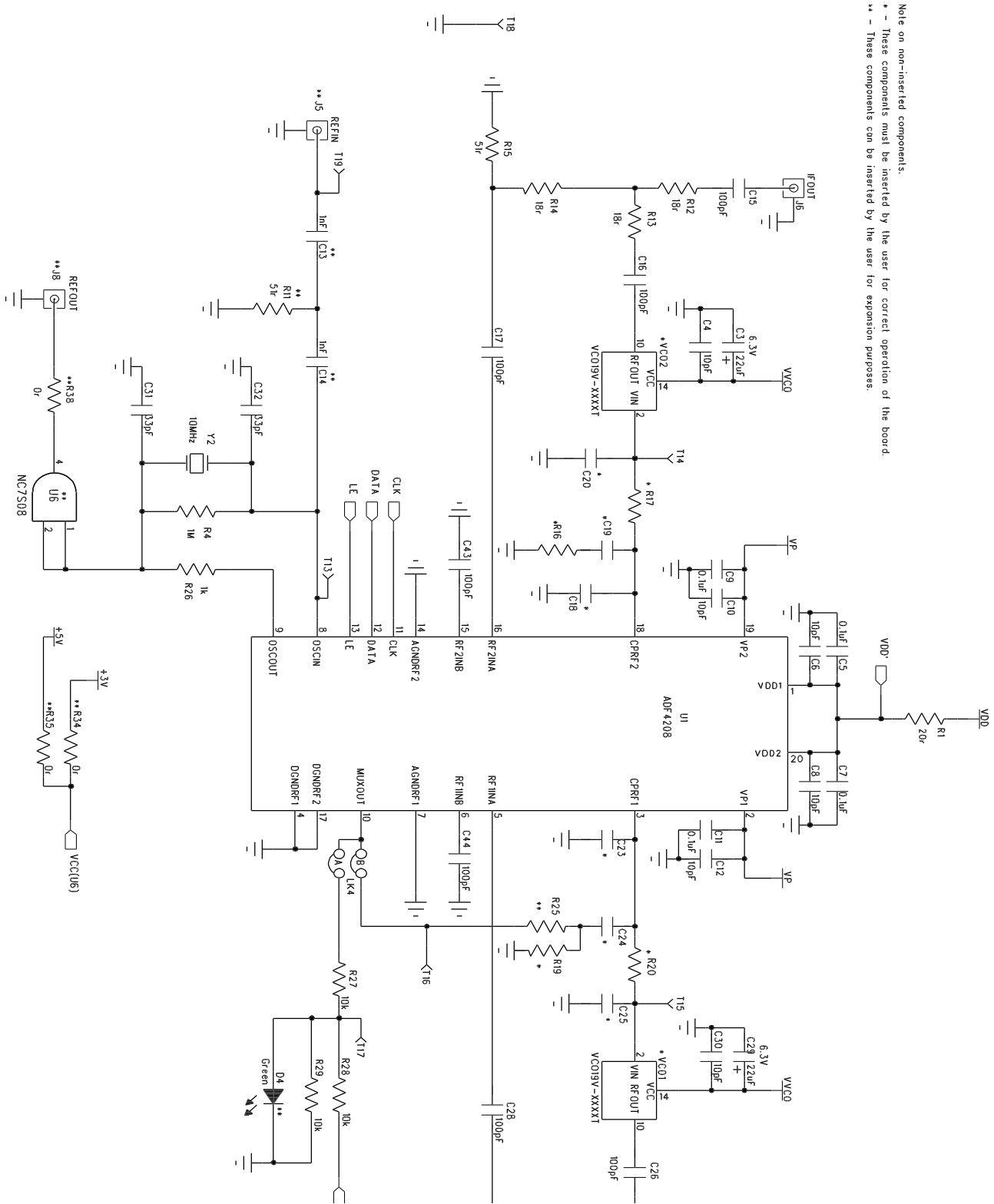

Figure 2. PC Cable Diagram

connectors. If the user wishes they may use their own power supplies and use the reference output. In this case, they need to insert SMA connectors to as shown on the silkscreen and block diagram. The AD7706 A/D converter is used to monitor the power supply voltage and current consumption of the ADF4208. This helps the user pick the optimum synthesizer settings for power consumption and also provides an alert if the battery voltage is too low to sustain the required 3V or 5V for the board supply.



Note on non-inserted components:
 * - These components must be inserted by the user for correct operation of the board.
 ** - These components can be inserted by the user for expansion purposes.

Figure 3. Evaluation Board Circuit Diagram (Page 1)

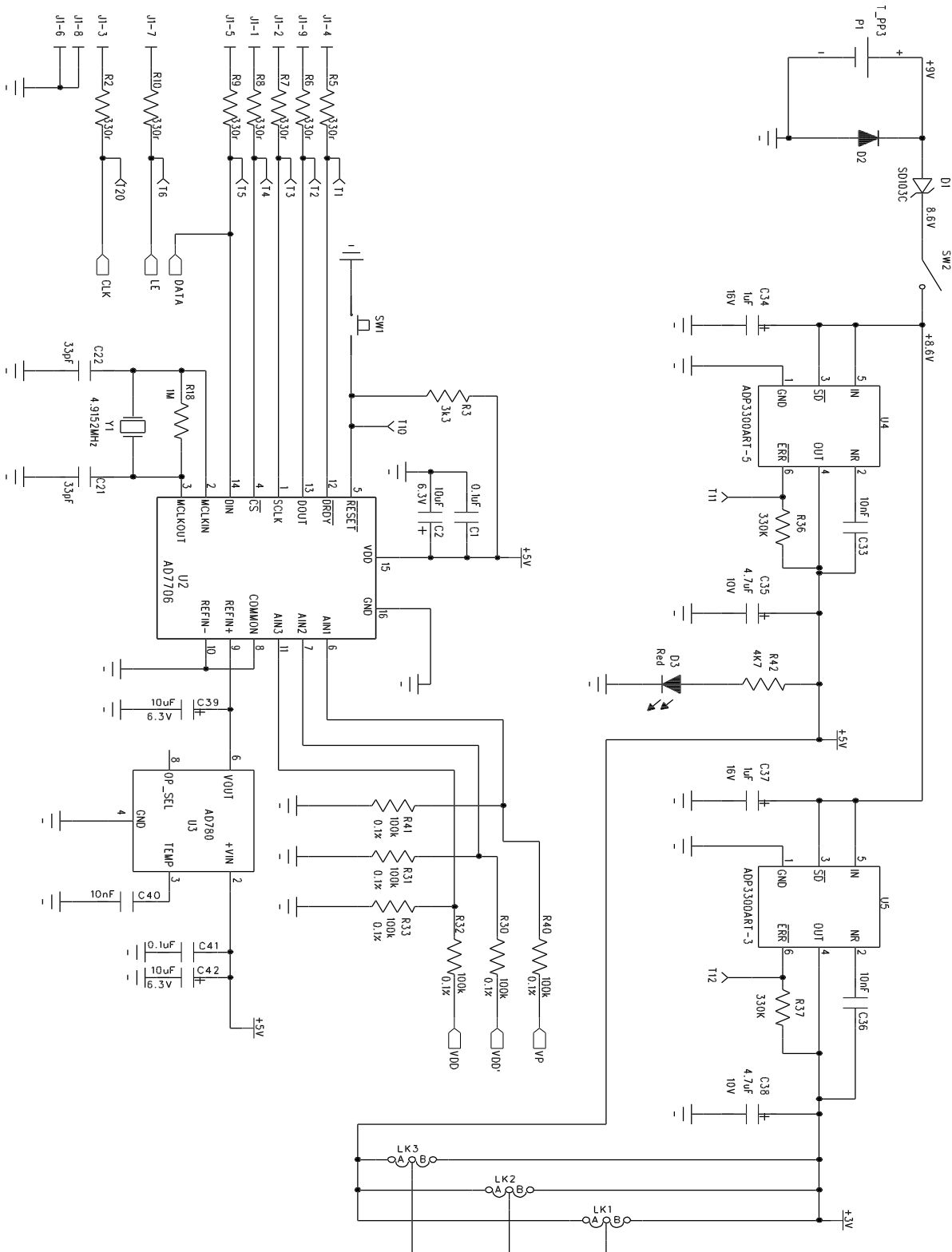

Figure 4. Evaluation Board Circuit Diagram (Page 2)

Software Description

The software comes on a CD. If the user runs "ADF4XXXEvaluationSoftware.exe" on the CD, then the install wizard installs the software. Follow the on-screen directions. The software will be installed in a default directory called "C:\Program Files\Analog Devices\ADF4xxx Evaluation Software". To run the software, simply double click on "ADF4XXX Eval Software.exe".

The front panel of the evaluation board software is shown below.

When the device window appears, choose the ADF4208 and click OK. The main software screen now appears.

Follow the steps below for initial setup to interface to the part.

Click on Choose Port, and the Port Connector window will appear. Choose the port that the cable is connected to on the PC and click OK. (Normally LPT1)

Click on REF IN Frequency, and the REF IN Frequency window will appear. Enter the reference frequency being used and click OK. This will be 10MHz with the Crystal. Click on RF VCO Output Frequency, and the Output Frequency window will appear. Enter the output frequency and PFD reference frequency, and click OK. Repeat this for the IF side.

Click On Prescaler, and the Prescaler window will appear. Grab the pointer, and choose the desired prescaler value. Click OK.

Click on the RF PD Polarity button to set the RF PD Polarity bit High.

Click on Charge Pump Current Setting 2 or Charge Pump Current Setting 1 and the Current Setting window will appear. Grab the pointer to set the Charge Pump Current Setting. Click OK.

The data is now set up, and other features can now be examined by the user.

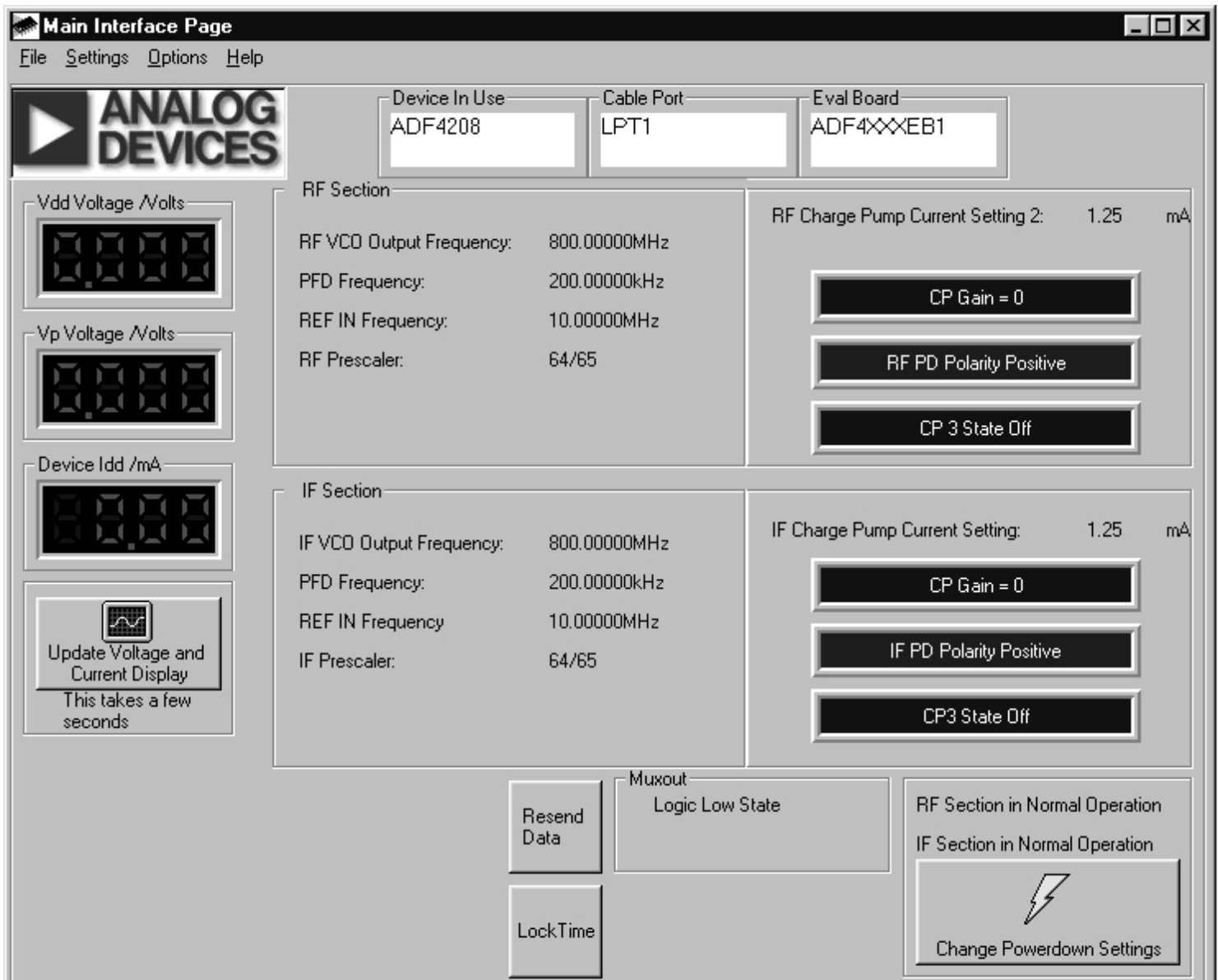

Figure 5. Software Front Panel

Table 1. Bill of Materials for the EVAL-ADF4208EB1

Qty	Reference	Description	Manufacturer	PCB DECAL	VALUE
1	U1	ADF4208BRU	ADI	TSSOP-20	ADF4208BRU
1	U2	AD7706BR	ADI	SO16WB	AD7706BR
1	U3	AD780AR	ADI	SO8NB	AD780AR
1	U4	ADP3300ART-5	ADI	SOT23-6	ADP3300ART-5
1	U5	ADP3300ART-3	ADI	SOT23-6	ADP3300ART-3
1	U6	Do Not Insert	Fairchild	SOT23-5	NC7SM508
1	VCO1	Do Not Insert	Vari-L		
1	VCO2	Do Not Insert	Vari-L		
1	Y1	4.9152MHz Crystal	Vectron International	HC49 low profile	VXA4-1011
1	Y2	10MHz Crystal	Vectron International	HC49 low profile	VXA4-1B2-10M00
1	D1	SD103C Schottky Diode	General Semiconductor	DO35	SD103C
1	D2	IN4001		D035	FEC 365-117
1	D3	Red Low Power LED	Vishay	LED	FEC 657-130
1	D4	Green Low Power LED (Do Not Insert)	Vishay	LED	FEC 657-141
6	C1 C5 C7 C9 C11 C41	Multi Layer Ceramic Capacitor	Murata	Case 0603	0.1uF
1	C2	Tantalum Capacitor	AVX	CAP\TAJ_B	10uF 6.3V
2	C3 C29	Tantalum Capacitor	AVX	CAP\TAJ_A	22uF 6.3V
6	C4 C6 C8 C10 C12 C30	Multi Layer Ceramic Capacitor	Murata	Case 0603	10pF
2	C13-14	Do Not Insert	Murata	Case 0603	1nF
8	C15-17 C26-28 C43-44	Multi Layer Ceramic Capacitor	Murata	Case 0603	100pF
1	C18	Do Not Insert	Murata	Case 0805	
1	C19	Do Not Insert	Murata	Case 0805	
1	C20	Do Not Insert	Murata	Case 0805	
4	C21-22 C31-32	Multi Layer Ceramic Capacitor	Murata	Case 0603	33pF
1	C23	Do Not Insert	Murata	Case 0805	
1	C24	Do Not Insert	Murata	Case 0805	
1	C25	Do Not Insert	Murata	Case 0805	
3	C33 C36 C40	Multi Layer Ceramic Capacitor	Murata	Case 0603	10nF
2	C34 C37	Tantalum Capacitor	AVX	CAP\TAJ_A	1uF 16V
2	C35 C38	Tantalum Capacitor	AVX	CAP\TAJ_A	4.7uF 10V
2	C39 C42	Tantalum Capacitor	AVX	CAP\TAJ_A	10uF 6.3V
1	R1	Resistor (Surface Mount)	Bourns	Case 0805	20r 1.0%
7	R2 R5-10	Resistor (Surface Mount)	Bourns	Case 0603	330r 1.0%
1	R3	Resistor (Surface Mount)	Bourns	Case 0603	3k3 1.0%
2	R4 R18	Resistor (Surface Mount)	Bourns	Case 0603	1M 1.0%
1	R11	Do Not Insert	Bourns	Case 0603	51r 1.0%
6	R12-14 R21-23	Resistor (Surface Mount)	Bourns	Case 0603	18r 1.0%
2	R15 R24	Resistor (Surface Mount)	Bourns	Case 0603	51r 1.0%
1	R16	Do Not Insert		Case 0805	
1	R17	Do Not Insert		Case 0805	
1	R19	Do Not Insert		Case 0805	
1	R20	Do Not Insert		Case 0805	
1	R25	Do Not Insert		Case 0805	
1	R26	Resistor (Surface Mount)	Bourns	Case 0603	1k 1.0%
3	R27-29	Resistor (Surface Mount)	Bourns	Case 0603	10k 1.0%
6	R30-33 R40-41	Resistor (Surface Mount)	Meggitt	Case 0603	100k 0.1%
3	R34-35 R38	Do Not Insert		Case 0603	0r 1.0%
2	R36 R37	Resistor (Surface Mount)	Bourns	Case 0603	330k 1.0%
1	R42	Resistor (Surface Mount)	Bourns	Case 0603	4k7 1.0%
1	SW1	Push Button Switch	Omron	SW\PB-SMALL	FEC 176-986
1	SW2	SPDT Switch - (Washable)	Apem	SW_SIP-3P	FEC 150-559
20	T1-20	Red Testpoint	W Hughes	TESTPOINT	FEC-240-345
1	J1	9 PIN D-TYPE MALE (HORIZ)	McMurdo	DCON9M	FEC 150-750
5	J2 J3 J4 J5 J8	Do Not Insert		SMA	
2	J6 J7	GOLD 50Ω SMA SOCKET	Pasternack	SMA	PE4118
3	LK1 LK2 LK3	3 pin header	Harwin	SIP-3P	FEC 512-047
1	LK4	4 pin header (2x2)	Harwin		FEC 512-035
4	LK1-4	Shorting Shunt	Harwin		FEC 150-410
4	Each Corner	Rubber Stick-On Feet	3M		FEC 148-922
2	P1	Pair PCB snap-on battery connector	Keystone	BATT_PP3	FEC 723-988
1	P1	9V PP3 Battery	Duracell		FEC 908-526
1	PCB	EVAL-ADF4208EB1			