



3.5mm Male to 3.5mm Male Test Cable 150 CM
Length Using PE-P160 Coax, RoHS

RF Cable Assemblies Technical Data Sheet

PE369-150CM

Configuration

- Connector 1: 3.5mm Male
- Connector 2: 3.5mm Male
- Cable Type: PE-P160

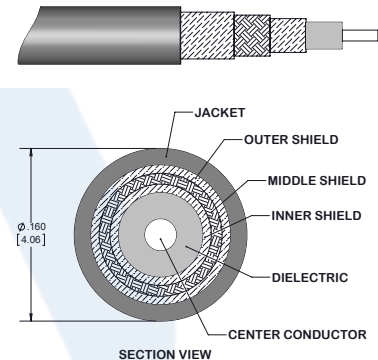

Electrical Specifications

Description	Minimum	Typical	Maximum	Units
Frequency Range	DC		34	GHz
VSWR			1.4:1	
Velocity of Propagation		78		%
RF Shielding	90			dB
Capacitance		26 [85.3]		pF/ft [pF/m]
Inductance		66 [216.54]		uH/ft [uH/m]

Specifications by Frequency

Description	F1	F2	F3	F4	F5	Units
Frequency	2.5	5	10	18	34	GHz
Insertion Loss (Max.)	1.17	1.68	2.5	3.36	5	dB
Insertion Loss (Typ.)	0.97	1.48	2.19	3.07	4.55	dB

Mechanical Specifications

Cable Assembly

Length* 59.055 in [150 cm]
Diameter 0.33 in [8.38 mm]

Click the following link (or enter part number in "SEARCH" on website) to obtain additional part information including price, inventory and certifications: [3.5mm Male to 3.5mm Male Test Cable 150 CM Length Using PE-P160 Coax, RoHS PE369-150CM](#)





3.5mm Male to 3.5mm Male Test Cable 150 CM Length Using PE-P160 Coax, RoHS

RF Cable Assemblies Technical Data Sheet

PE369-150CM

Weight 0.18 lbs [81.65 g]

Cable

Cable Type PE-P160
 Impedance 50 Ohms
 Inner Conductor Type Solid
 Inner Conductor Material and Plating Copper, Silver
 Dielectric Type PTFE
 Number of Shields 3
 Shield Layer 1 Silver Plated Copper
 Shield Layer 2 Aluminum Tape
 Shield Layer 3 Silver Plated Copper
 Jacket Material ETFE, Gray
 Jacket Diameter 0.16 in [4.06 mm]

One Time Minimum Bend Radius 0.8 in [20.32 mm]
 Typical Flex Cycles 10,000

Connectors

Description	Connector 1	Connector 2
Type	3.5mm Male	3.5mm Male
Impedance	50 Ohms	50 Ohms
Contact Material and Plating	Beryllium Copper, Gold	Beryllium Copper, Gold
Contact Plating Specification	ASTM-B488 50µ In. Minimum	ASTM-B488 50µ In. Minimum
Dielectric Type	PCTFE	PCTFE
Body Material and Plating	Passivated Stainless Steel	Passivated Stainless Steel
Body Plating Specification	SAE-AMS-2700	SAE-AMS-2700
Coupling Nut Material and Plating	Passivated Stainless Steel	Passivated Stainless Steel
Coupling Nut Plating Specification	SAE-AMS-2700	SAE-AMS-2700
Hex Size	5/16 Inch	5/16 Inch
Torque	8 in-lbs [0.9 Nm]	8 in-lbs [0.9 Nm]

Mechanical Specification Notes:

*All cable assemblies have a length tolerance of 1.5% or ± 3/8", whichever is greater.

Environmental Specifications

Temperature

Operating Range -45 to +125 deg C

Click the following link (or enter part number in "SEARCH" on website) to obtain additional part information including price, inventory and certifications: [3.5mm Male to 3.5mm Male Test Cable 150 CM Length Using PE-P160 Coax, RoHS PE369-150CM](#)



3.5mm Male to 3.5mm Male Test Cable 150 CM Length Using PE-P160 Coax, RoHS

RF Cable Assemblies Technical Data Sheet

PE369-150CM

Compliance Certifications (see [product page](#) for current document)

Plotted and Other Data

Notes:

- Values at 25°C, sea level.

How to Order

Part Number Configuration:

PE369 - xx uu

Unit of Measure:
cm = Centimeters
<blank> = Inches
Length
Base Number

Example: PE369-12 = 12 inches long cable
PE369-100cm = 100 cm long cable

3.5mm Male to 3.5mm Male Test Cable 150 CM Length Using PE-P160 Coax, RoHS from Pasternack Enterprises has same day shipment for domestic and International orders. Our RF, microwave and millimeter wave products maintain a 99.4% availability and are part of the broadest selection in the industry.

Click the following link (or enter part number in "SEARCH" on website) to obtain additional part information including price, inventory and certifications: [3.5mm Male to 3.5mm Male Test Cable 150 CM Length Using PE-P160 Coax, RoHS PE369-150CM](#)

URL: <https://www.pasternack.com/3.5mm-male-3.5mm-male-pe-p160-cable-assembly-pe369-150cm-p.aspx>

The information contained in this document is accurate to the best of our knowledge and representative of the part described herein. It may be necessary to make modifications to the part and/or the documentation of the part, in order to implement improvements. Pasternack reserves the right to make such changes as required. Unless otherwise stated, all specifications are nominal. Pasternack does not make any representation or warranty regarding the suitability of the part described herein for any particular purpose, and Pasternack does not assume any liability arising out of the use of any part or documentation.

PE369-150CM CAD Drawing

3.5mm Male to 3.5mm Male Test Cable 150 CM Length Using PE-P160 Coax, RoHS

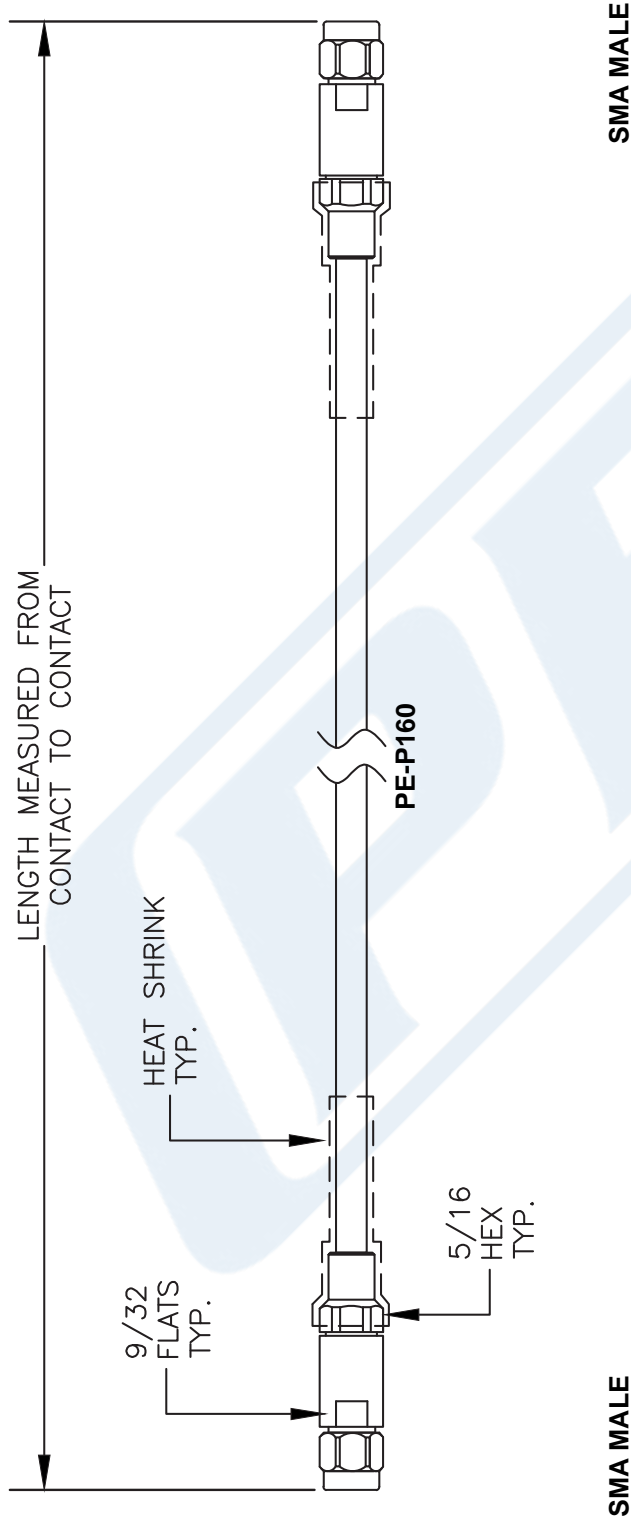

Part Number Configuration		How To Order	
PE3	zzz yy - xx uu	Part # Ext.	Length In Inches
00 - 99999		-12	12"
LF = RoHS Compliant		-24	24"
< Blank > = Standard		-36	36"
Note: LF applies only to RF cables		-48	48"
		-60	60"
		-xx	Custom Length
		Part # Ext.	Length In Centimeters
		-25CM	25Cm
		-50CM	50Cm
		-75CM	75Cm
		-100CM	100Cm
		-125CM	125Cm
		-xxCM	Custom Length

NOTES:
 1. UNLESS OTHERWISE SPECIFIED ALL DIMENSIONS ARE NOMINAL.
 2. ALL SPECIFICATIONS ARE SUBJECT TO CHANGE WITHOUT NOTICE AT ANY TIME.
 3. DIMENSIONS ARE IN INCHES [mm].
 4. LENGTH TOLERANCE IS ± 1.5% OR 3/8", WHICHEVER IS GREATER.

DWG TITLE
PE369

PE PASTERNAK
 Pasternack Enterprises, Inc.
 P.O. Box 16759 | Irvine | CA | 92623
 Phone: (949) 261-1920 | Fax: (949) 261-7451
 Website: www.pasternack.com | E-Mail: sales@pasternack.com

FSCM NO. 53919	CAD FILE 061213	SCALE N/A	SIZE A	2233
----------------	-----------------	-----------	--------	------