

**Huck
Fasteners**

From Cordant Technologies

NOSE ASSEMBLY DATA SHEET

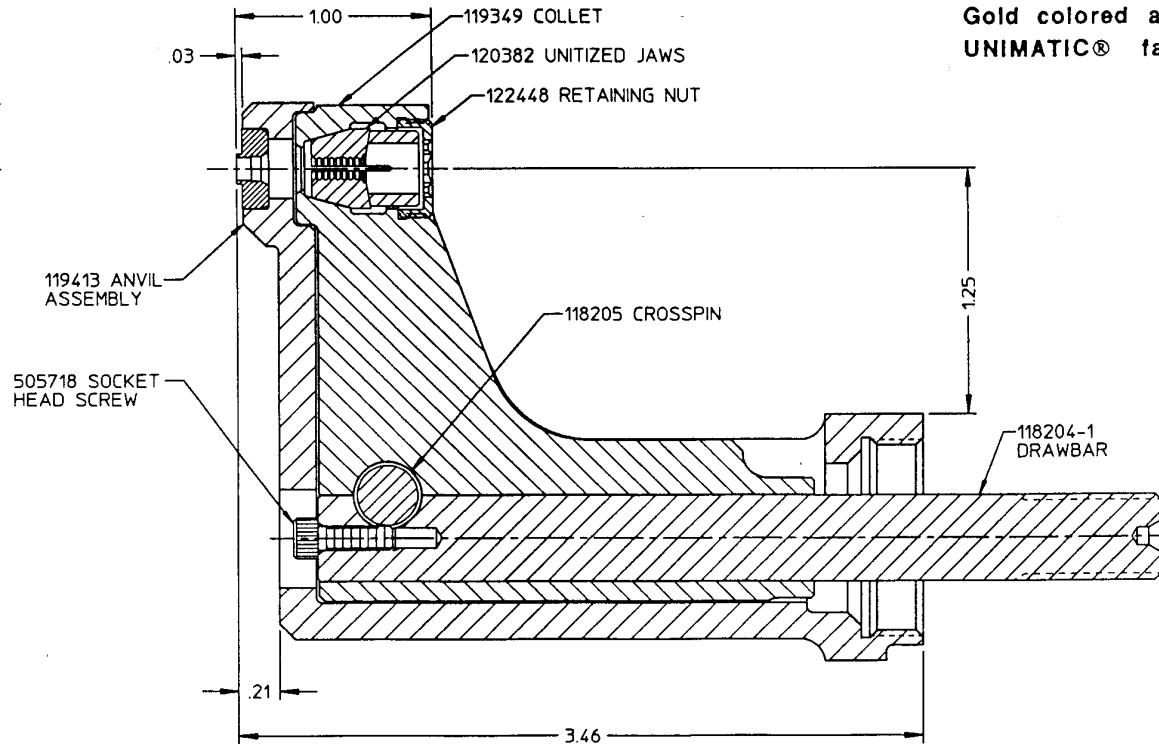
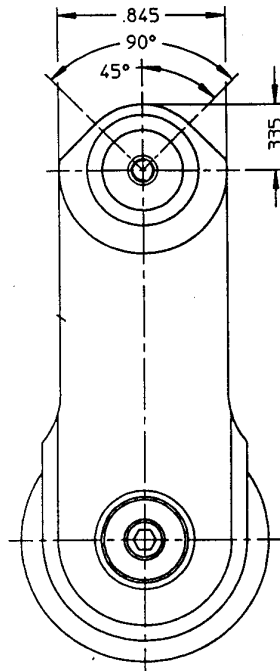

Gold colored anvil for UNIMATIC® fasteners.

©Huck International, Inc. 1995
 ©Registered Trademark of Huck International, Inc., Irvine, CA
 ™Trademark of Huck International, Inc., Irvine, CA

- 1 MAXIMUM RECOMMENDED STROKE: .500
- 2 FOR USE WITH THE 225/245 TOOL, USE ATTACHMENT P/N 119400 AND STROKE LIMITER 118362.
- 3 FOR USE WITH THE 2500 TOOL, USE ATTACHMENT P/N 119400 AND STROKE LIMITER KIT 119888.
- 4 FOR OTHER TOOLS AND/OR OTHER TOOL AND STROKE COMBINATIONS, CONSULT ENGINEERING DEPARTMENT.
- 5 OPTIONAL DEFLECTOR KIT P/N 122911 AVAILABLE FOR THIS NOSE ASSEMBLY.
- 6 OPTIONAL LOOSE CHUCK JAW KIT P/N 123487 AVAILABLE FOR THIS NOSE ASSEMBLY CONSISTS OF:
 122746 CHUCK JAWS
 118207 FOLLOWER
 505717 SPRING
 122449 LOCATER
 122448 RETAINING NUT

U.S. Patent No. 4,796,455

U.S. Patent No. 4,347,728

99-1716-1	NOSE ASSEMBLY	Huck International, Inc. Installation System Division 1 Corporate Drive - Kingston, NY 12401	
		TYPE: UNIMATIC, Blind Bolt, Offset FOR: -05, NAS1919 & NAS1921 TOOL: 206-1; 206-375	
OTHER		ISSUED:	9-89
		REVISED:	1-95

Nose Assembly Maintenance

1. Prepare tool per manual.

WARNING

Before maintenance or adjustments POWERIG Hydraulic Unit must be disconnected from electrical or air supply. If not disconnected, severe personal injury and/or damage may result.

Disconnect POWERIG Hydraulic Unit's power source. Connect tool's hoses and controls to unit. Reconnect power source. Depress trigger for 30 seconds piston stops completely forward. Disconnect controls and **RETURN** hose **tool piston must be remain completely forward.**

2. **Disassembly/assembly as applies:** Remove parts of nose assembly for inspection and maintenance.

Anvil:

Pressed in anvil insert is pressed out with drift and arbor press press new insert in squarely to prevent cracking.

Collet/drawbar:

Assemble collet as shown. Use 7/32, 1/4, 5/16 or 3/8 hex key (tighten wrench-tight) or 0100 TRUARC pliers. Slide drawbar into collet. Push crosspin through collet and drawbar. With LOCKTITE on threads, lock collet to drawbar with tightly installed socket head screw as applicable, use either 3/32 or 9/64 hex key.

3. Attaching to tool:

While holding front of collet against back of anvil, screw assembly onto/into tool. When assembly stops turning, collet should still be against back of anvil.

4. Checking nose assembly:

See **WARNING** connect controls and **RETURN** hose. Reconnect hydraulic unit to power source. Install fasteners in test plate of correct thickness with proper size holes inspect installed fasteners.

Notes

1. To extend jaw life: Disassemble nose assembly periodically; clean and inspect components use a pick to clean jaw grooves. **CAUTION:** Wash parts in **mineral spirits or isopropyl alcohol** only dry Orings; urethane jaw assemblies **immediately** after cleaning as prolonged contact with solvent causes swelling dry other parts.

2. Replacements as applicable: Anvil inserts; jaws; springs; retaining rings.

3. Service items as required: 3/32 hex key, 502293; 9/64 hex key, 502655; 7/32 hex key, 502297; 1/4 hex key, 502445; 5/16 hex key, 502446; 3/8 hex key, 502651; LOCTITE, 503657; VIBRA-TITE, 502125; TRUARC (0100) pliers, 502857; NYLON brushes: 105805 (05 & 06), 105806 (08), 107070 (10 & 12)