

Tous droits strictement reserves. Reproduction ou communication a des tiers interdite sous quelque forme que ce soit sans autorisation écrite du propriétaire. Propriete de c FCI. Droits de reproduction FCI.

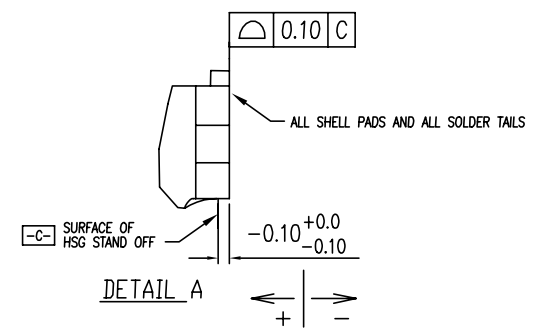

All rights strictly reserved. Reproduction or issue to third parties in any form whatever is not permitted without written authority from the proprietor. Property of FCI. Copyright FCI.

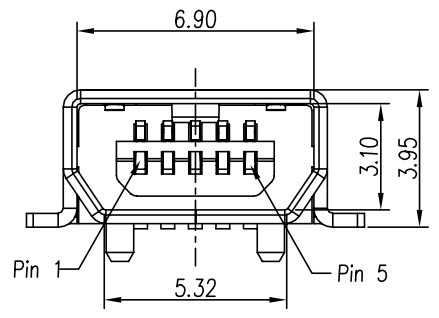
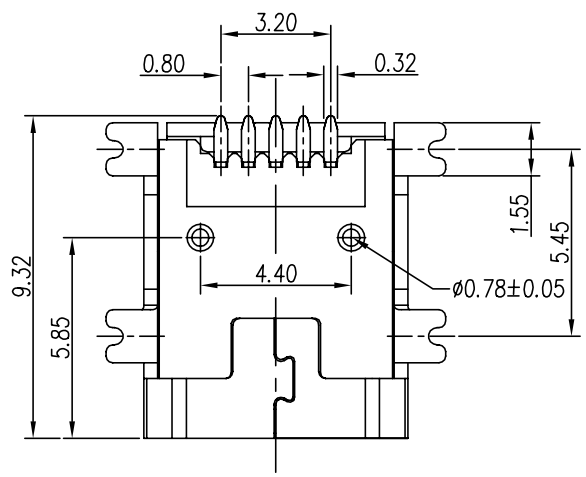
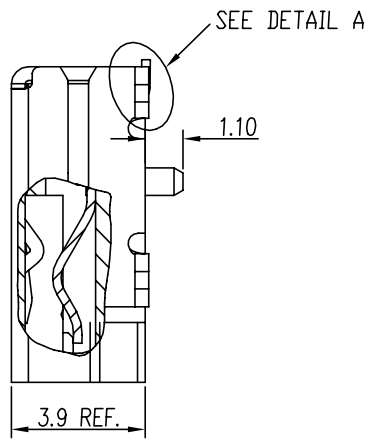
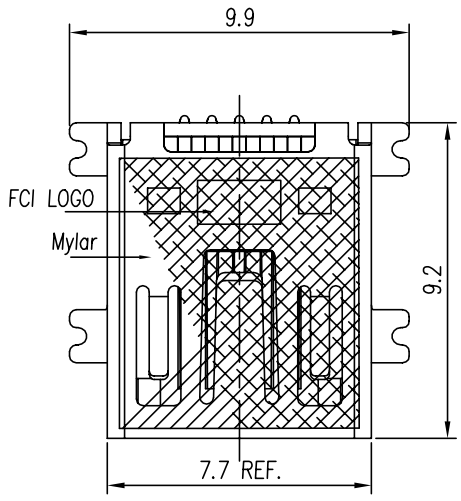

|             |                |      |            |                                       |               |         |       |               |   |                           |       |
|-------------|----------------|------|------------|---------------------------------------|---------------|---------|-------|---------------|---|---------------------------|-------|
| mat'l. code |                |      |            | tolerances unless otherwise specified |               |         |       | CUSTOMER COPY |   | FCI<br>www.fciconnect.com |       |
| ltr         | ecn no         | dr   | date       | linear                                | .X ± 0.30     |         |       | projection    | title   |                           |       |
| F           | T06-0074       | A.C  | 04/10/2006 |                                       | .XX ± 0.20    |         |       |               | MINI USB AB TYPE RECEPTACLE CONNECTOR, R/A SMT TYPE |                           |       |
| G           | T06-0201       | A.C  | 12/14/2006 |                                       | .XXX ± 0.10   |         |       |               |   |                           |       |
| H           | T09-1090       | J.H  | 06/22/2009 | angles                                | 0° ± 3°       |         |       | MM            | product family 511                                  |                           | code  |
| J           | T10-0095       | J.H  | 12/27/2010 | dr                                    | JASMINE CHANG | 9/09/03 | scale |               | size dwg no   |                           | NT    |
| K           | T-004677       | J.H  | 07/27/2011 | engr                                  | ALLEN CHANG   | 6/16/08 |       |               | 10033527  |                           | sheet |
| L           | ELX-N-007323   | A.ZH | 10/25/2011 | chr                                   | ROGER LIN     | 6/16/08 |       |               |   | 1 of 2                    |       |
|             |                |      |            | appd                                  | JAMES HSU     | 6/16/08 | N/A   |               |   |                           |       |
| sheet index | revision sheet | L    | 1~2        |                                       |               |         |       |               |   |                           |       |



PROD NO  
SEE NOTES

NOTES:

- MATERIAL:  
HOUSING: HIGH TEMP THERMOPLASTIC, GLASS FIBER FILLED.  
UL 94V-0 RATED, COLOR IN BLACK.  
CONTACT: COPPER ALLOY.  
SHELL: COPPER ALLOY.
- FINISH:  
CONTACT: UNDERPLATED 50u" MIN. NICKEL OVER ALL  
100u" MIN. MATTE TIN PLATED IN SOLDERING AREA FOR LEAD FREE VERSION.  
SELECTIVE GOLD PLATED IN CONTACT AREA.  
SHIELD: N: NICKEL 40u"~120u" PLATED OVERALL.  
T: SELECTIVE 60u" MIN. MATTE TIN ON LEGS OVER 40u"~120u" NICKEL.
- 10033527-X3212XL: THE HOUSING WILL WITHSTAND EXPOSURE TO 260° PEAK TEMPERATURE FOR 10 SECONDS IN A IR REFLOW APPLICATION. AND THIS PRODCUT MEETS EUROPEAN UNION DIRECTIVES AND OTHER COUNTRY REGULATIONS AS DESCRIBED IN GS-22-008.
- PRODUCT SPEC: GS-12-174; PACKAGE SPEC: GS-14-873
- PART NUMBER 10033527N3112LF TO BE EQUAL TO 10033527-T3112LF WITH Ni+Sn PLATING.  
PART NUMBER 10033527N3212LF TO BE EQUAL TO 10033527-T3212LF WITH Ni+Sn PLATING.
- PRODUCT ORDERING DATA :

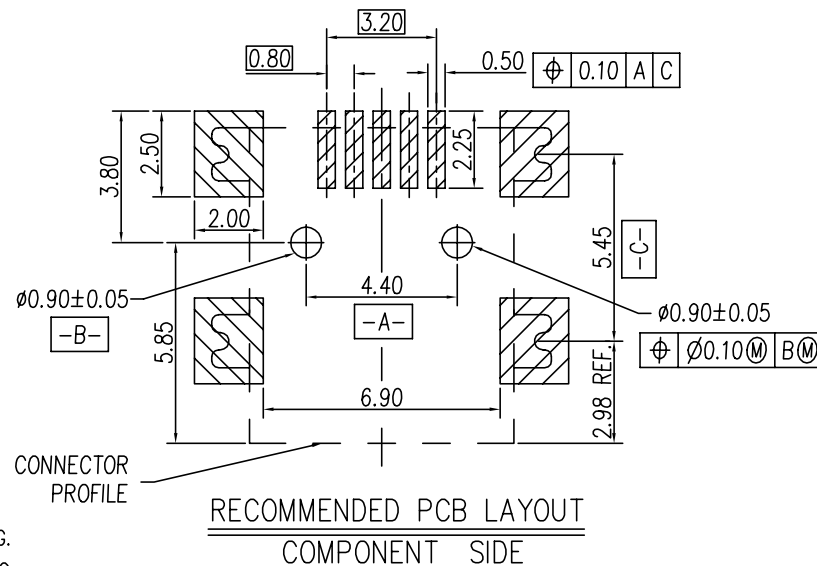

10033527 - X X X X X M LF

SEE NOTE 5 FOR THE SPECIFIC P/N ASSIGNMENT FOR SPECIFIC CUSTOMER

- LF: LEAD FREE PLATING
- M: WITH MYLAR
- BLANK: WITHOUT MYLAR
- PACKAGING METHOD:  
2: TAPE & REEL PACKAGING.
- POST OPTION:  
1 : WITH PLASTIC POST.
- HSG MATERIAL:  
1 OR 2: HIGH TEMP THERMOPLASTIC.
- PLATING IN CONTACT AREA:  
3 : 30u" Au.
- N: NICKEL FOR SHIELD.
- T: SELECTIVE TIN ON LEGS.

|             |                |    |      |                                       |               |         |            |   |              |                           |  |
|-------------|----------------|----|------|---------------------------------------|---------------|---------|------------|---|--------------|---------------------------|--|
| mat'l. code |                |    |      | tolerances unless otherwise specified |               |         |            | CUSTOMER COPY                                       |              | FCI<br>www.fciconnect.com |  |
| ltr         | ecn no         | dr | date | linear                                | .X ± 0.30     |         | projection | title   |              |                           |  |
| L           |                |    |      |                                       | .XX ± 0.20    |         |            | MINI USB AB TYPE RECEPTACLE CONNECTOR, R/A SMT TYPE |              |                           |  |
|             |                |    |      |                                       | .XXX ± 0.10   |         |            | product family 511 code NT                          |              |                           |  |
|             |                |    |      | angles                                | 0° ± 3°       |         | MM         |   | size dwg no  |                           |  |
|             |                |    |      | dr                                    | JASMINE CHANG | 9/09/03 | scale      |   | 10033527     |                           |  |
|             |                |    |      | enr                                   | ALLEN CHANG   | 6/16/08 | N/A        |   | sheet 2 of 2 |                           |  |
|             |                |    |      | chr                                   | ROGER LIN     | 6/16/08 |            |   |              |                           |  |
|             |                |    |      | appd                                  | JAMES HSU     | 6/16/08 |            |   |              |                           |  |
| sheet index | revision sheet |    |      |                                       |               |         |            |   | cage code    |                           |  |