



**Size:**  
2.0 x 1.0 x 0.597 inches  
50.80 x 25.40 x 15.16 mm

**Weight:**  
1.06oz (30g)

**FEATURES**

- Isolation Class II
- RoHS Compliant
- 5 Watts Output Power
- Single Outputs
- Fully Encapsulated Plastic Case
- UL/cUL, CE, and CB Safety Approvals
- PCB Mountable Switching Power Supply
- -25°C to +70°C Operating Temperature Range
- Optional -40°C~+70°C Operating Temperature Range
- Universal Input Range: 90-264VAC (120-370VDC)
- Short Circuit, Over Power, and Over Voltage Protection
- Screw Terminal Mechanical Options Available

**DESCRIPTION**

The PSAHC series of AC/DC switching power supplies provides up to 5.5 Watts of output power in a 2.0" x 1.0" x 0.597" encapsulated PCB mountable package. This series consists of single output models with a universal input range of 90-264VAC (120-370VDC). Some features include low ripple and noise, -25°C to +70°C operating temperature range, and over power, over voltage, and short circuit protection. The PSAHC series also has two types of screw terminal mechanical options and an extended operating temperature option available. All models are RoHS compliant and have UL/cUL, CB, and CE safety approvals.

**MODEL SELECTION TABLE**

Model Number	Input Voltage Range	Output Voltage	Output Current		Output Power	Efficiency	Maximum Capacitive Load
			Min Load	Max Load			
PSAHC-3.3S	90~264 VAC (120~370 VDC)	3.3 VDC	0%	1250mA	4W	68%	13,800µF
PSAHC-5S		5 VDC	0%	1000mA	5W	71%	6000µF
PSAHC-12S		12 VDC	0%	420mA	5W	75%	1400µF
PSAHC-15S		15 VDC	0%	333mA	5W	75%	1000µF
PSAHC-24S		24 VDC	0%	230mA	5.5W	77%	170µF

**NOTES**  
 1. For -40°C to +70°C extended operating temperature range please add the suffix -E1 to the model number (Ex: PSAHC-12S-E1).  
 2. Screw terminal mechanical options available (see page 4). Please call factory for ordering details.

**BLOCK DIAGRAM**

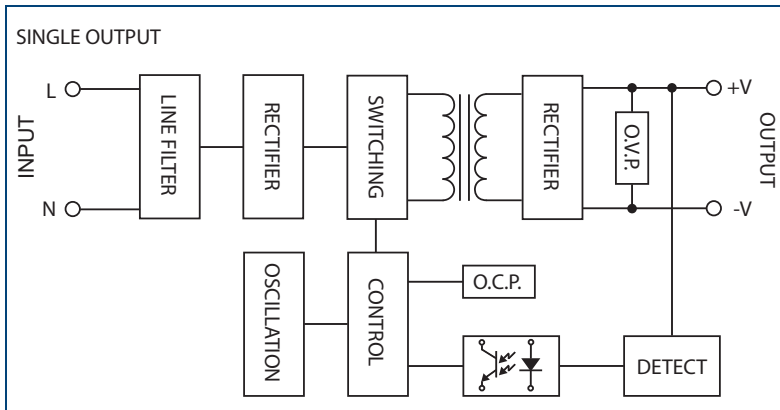

**RIPPLE & NOISE SETUP**

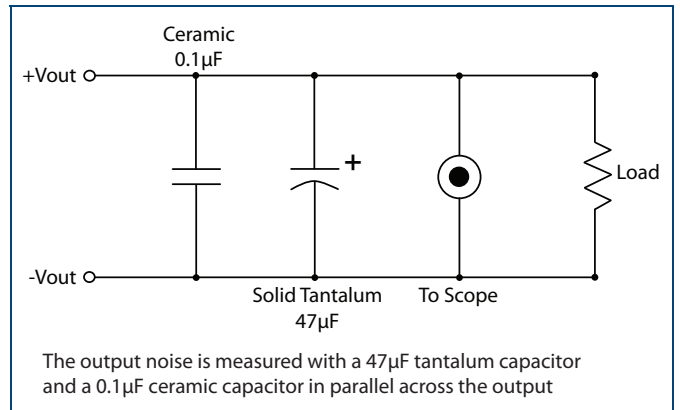

**SPECIFICATIONS: PSAHC SERIES**

All specifications are based on 25°C, Nominal Input Voltage, and Maximum Output Current unless otherwise noted.  
 We reserve the right to change specifications based on technological advances.

SPECIFICATION		TEST CONDITIONS	Min	Typ	Max	Unit
<b>INPUT SPECIFICATIONS</b>						
Input Voltage	AC input voltage range		90		264	VAC
	DC input voltage range		120		370	VDC
Input Frequency			47		440	Hz
Input Current	At 115VAC and full load				110	mA
	At 230VAC and full load				70	
Inrush Current (< 2ms)	Standard Models	At 115VAC			10	A
		At 230VAC			20	
	"-E1" Suffix Models	At 115VAC			23	A
		At 230VAC			46	
External Fuse (recommended)			1.5A slow blow type			
<b>OUTPUT SPECIFICATIONS</b>						
Output Voltage			See Table			
Voltage Accuracy			-2		+2	%
Line Regulation	Low line to high line		-0.3		+0.3	%
Load Regulation	10% - 100% load		-0.5		+0.5	%
Output Power			See Table			
Output Current			See Table			
Minimum Load			0			%
Ripple & Noise	Ripple	Measured at 20MHz BW and with a 47µF tantalum capacitor and a 0.1µF ceramic capacitor in parallel across the output. (See page 1)	< 0.2% Vout + 40mV max			Vp-p
	Noise		< 0.5% Vout +50mV max.			
Maximum Capacitive Load			See Table			
Hold-Up Time			15			ms
Temperature Coefficient			-0.02		+0.02	%/°C
<b>PROTECTION</b>						
Short Circuit Protection			Hiccup mode, indefinite (auto-recovery)			
Over Voltage Protection			Zener diode clamp			
Over Power Protection			Hiccup technique, auto-recovery			
<b>GENERAL SPECIFICATIONS</b>						
Efficiency			See Table			
Switching Frequency				132		KHz
Isolation Voltage	Input to Output		3000			VAC
Leakage Current					0.75	mA
<b>ENVIRONMENTAL SPECIFICATIONS</b>						
Operating Temperature	Standard Models		-25		+70	°C
	"-E1" Suffix Models		-40		+70	
Storage Temperature			-40		+85	°C
Humidity					95	% RH
Cooling			Free air convection			
MTBF	25°C (MIL-HDBK-217F)		360,000			hours
<b>PHYSICAL SPECIFICATIONS</b>						
Weight			1.06oz (30g)			
Case Material			Plastic resin with fiberglass (Flammability to UL 94V-0)			
Dimensions (L x W x H)			2.0 x 1.0 x 0.597 inches (50.8 x 25.4 x 15.16 mm)			
<b>SAFETY &amp; EMC</b>						
Safety Approvals			CE, UL/cUL, CB			
EMC	EMI (Conducted and Radiated Emissions)		EN 55022 Class B			
	EMS (Noise Immunity)		EN 55024			

**DERATING**

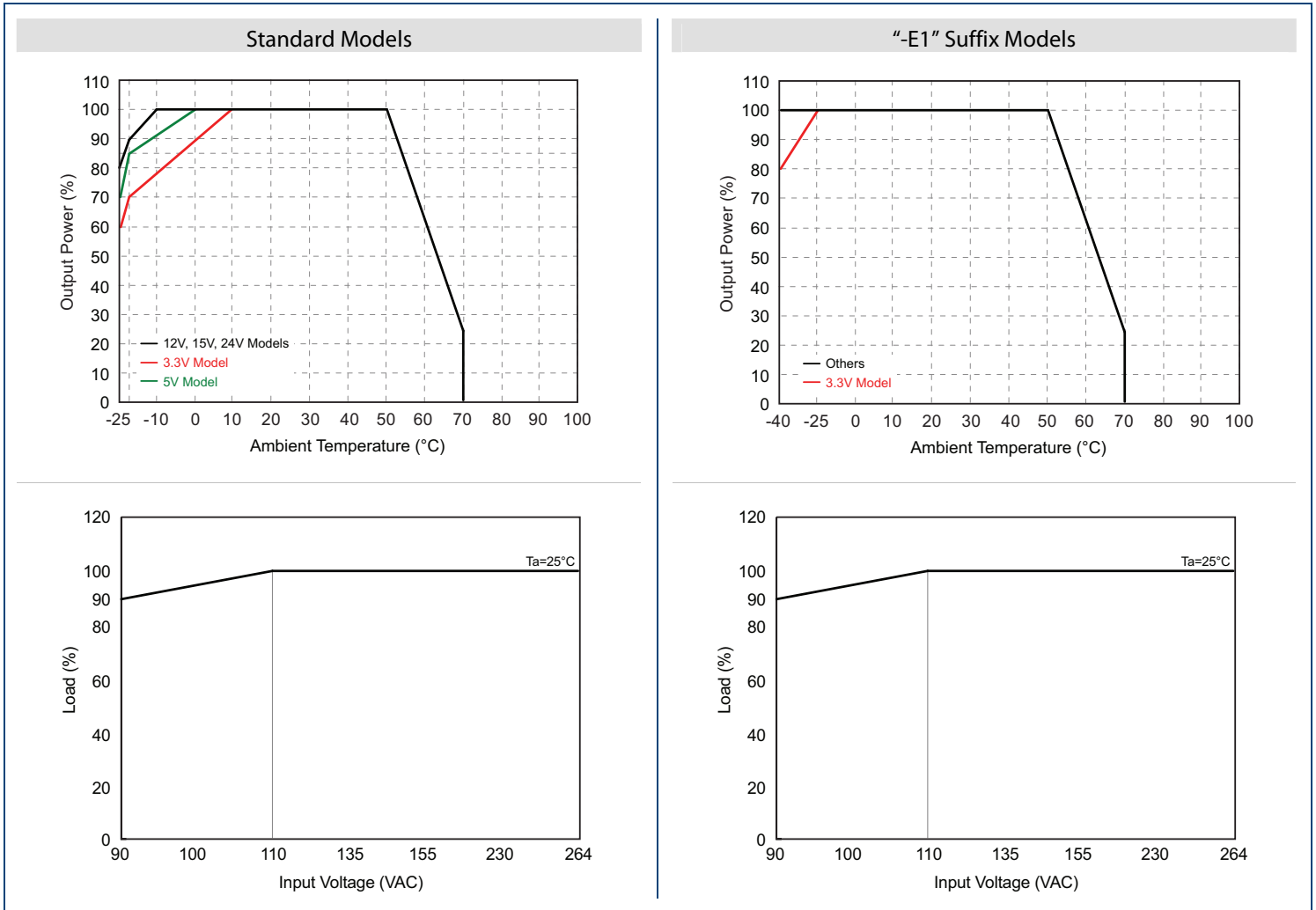

**MECHANICAL DRAWING**

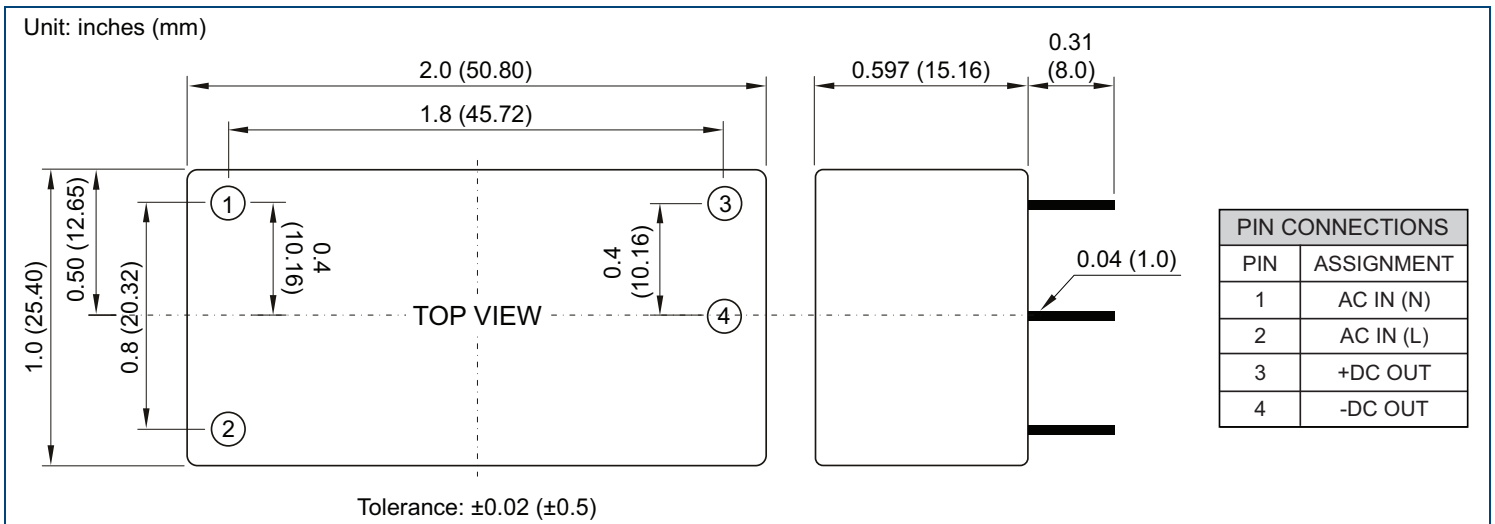

SCREW TERMINAL OPTIONS

PSAHC-A2



PIN CONNECTIONS	
PIN	ASSIGNMENT
1	NO CONNECT
2	AC IN (N)
3	AC IN (L)
4	NO CONNECT
5	+DC OUT
6	-DC OUT
7	NO CONNECT
8	NO CONNECT

Unit: inches (mm)

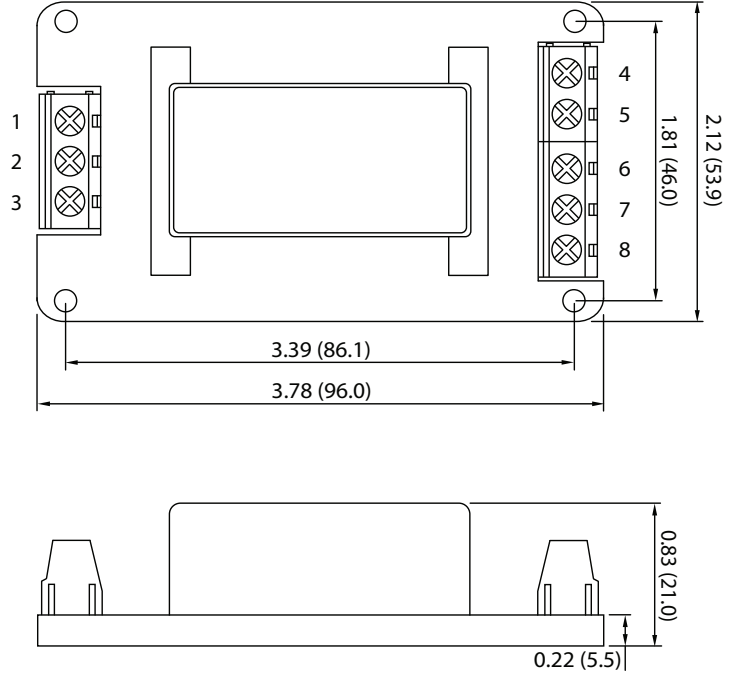

PSAHC-A5



PIN CONNECTIONS	
PIN	ASSIGNMENT
1	NO CONNECT
2	AC IN (N)
3	AC IN (L)
4	NO CONNECT
5	+DC OUT
6	-DC OUT
7	NO CONNECT
8	NO CONNECT

Unit: inches (mm)

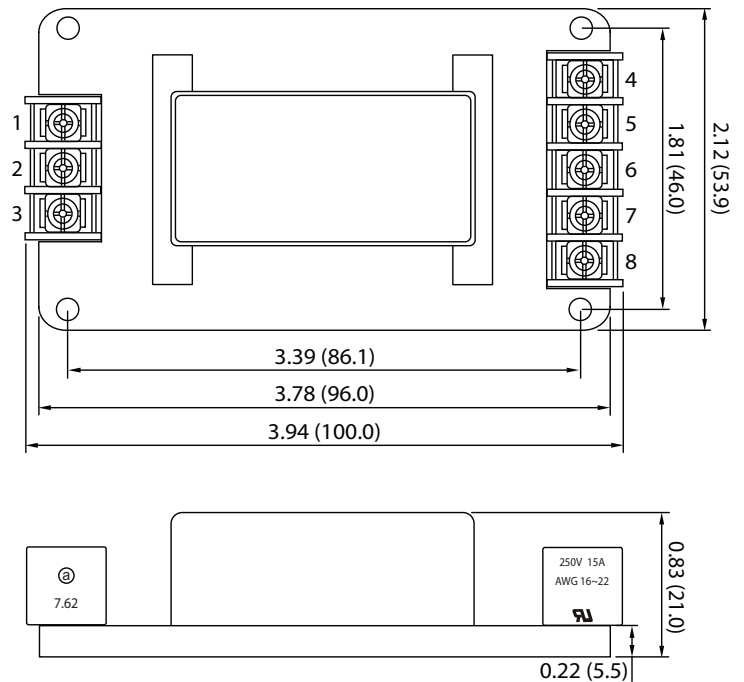

## COMPANY INFORMATION

---

Wall Industries, Inc. has created custom and modified units for over 50 years. Our in-house research and development engineers will provide a solution that exceeds your performance requirements on-time and on budget. Our ISO9001-2008 certification is just one example of our commitment to producing a high quality, well-documented product for our customers.

Our past projects demonstrate our commitment to you, our customer. Wall Industries, Inc. has a reputation for working closely with its customers to ensure each solution meets or exceeds form, fit and function requirements. We will continue to provide ongoing support for your project above and beyond the design and production phases. Give us a call today to discuss your future projects.

Contact **Wall Industries** for further information:

Phone: ☎ (603)778-2300  
Toll Free: ☎ (888)597-9255  
Fax: ☎ (603)778-9797  
E-mail: [sales@wallindustries.com](mailto:sales@wallindustries.com)  
Web: [www.wallindustries.com](http://www.wallindustries.com)  
Address: 5 Watson Brook Rd.  
Exeter, NH 03833