



The Future of Analog IC Technology®

EV3304DD-00A

1.3A Fixed Frequency White LED Driver Evaluation Board

DESCRIPTION

The EV3304DD-00A is an evaluation board for the MP3304CDD, a monolithic step-up converter designed for driving arrays of WLEDs from 5V input or a single cell Lithium Ion battery. The EV board is optimized for the load of 3 white LEDs in series, 10 strings panel.

The MP3304 uses current mode, fixed frequency architecture to regulate the LED current, which is measured through an external current sense resistor. Its low 200mV feedback voltage reduces power loss and improves efficiency.

The MP3304 features up to 50kHz true PWM dimming, which allows the flexible control of the backlighting luminance under wide range of the ambient brightness, and also avoids the possibility of PWM dimming audible noise.

The MP3304 is turned off if an over-voltage condition is present due to an open circuit condition. MP3304 also includes under-voltage lockout, current limiting and thermal overload protection preventing damage in the event of an output overload.

The MP3304 is available in small 8-pin QFN (2mm x 3mm) package.

FEATURES

- 5V Input Voltage Range
- Drives up to 30 White LEDs
- Up to 88% Efficiency
- Open Load Shutdown
- Fully Assembled and Tested

APPLICATIONS

- Cell Phones
- Handheld Computers and PDAs
- Digital Still Cameras
- Small LCD Displays

ELECTRICAL SPECIFICATIONS

Parameter	Symbol	Value	Units
Input Voltage	V_{IN}	5	V
# of WLEDs		30(3 in series, 10 strings paralleled)	
LED Current	I_{LED}	200	mA

"MPS" and "The Future of Analog IC Technology" are Registered Trademarks of Monolithic Power Systems, Inc.

EV3304DD-00A EVALUATION BOARD



(L x W x H) 1.8" x 1.8" x 0.4"
4.6cm x 4.6cm x 1.0cm

Board Number	MPS IC Number
EV3304DD-00A	MP3304CDD

V_{IN} vs. Efficiency

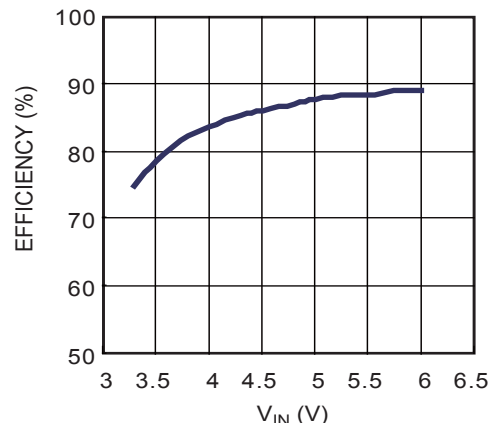

EVALUATION BOARD SCHEMATIC

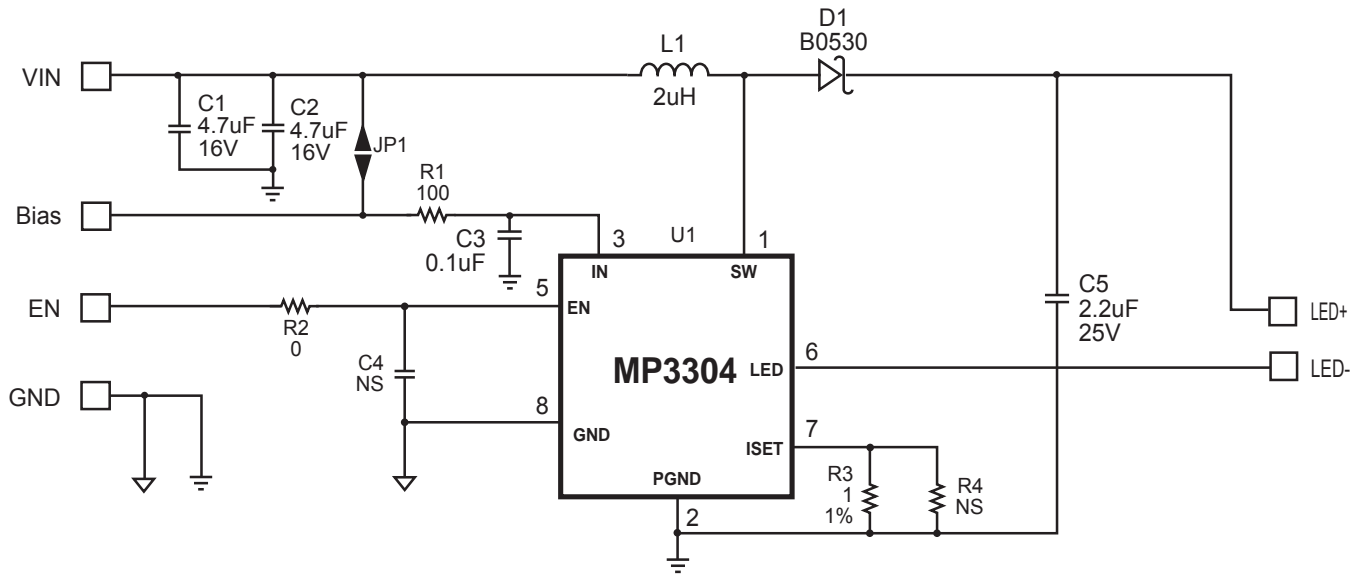

EV3304DD-00A BILL OF MATERIALS

Qty	Ref	Value	Description	Package	Manufacturer	Part Number
2	C1, C2	4.7uF	Ceramic Capacitor, 16V, X5R	0805	muRata	GRM21BR61C475KA88
1	C3	0.1uF	Ceramic Capacitor, 16V, X7R	0603	muRata	GRM188R71C104KA01D
1	C4	NS	Not Stuffed			
1	C5	2.2uF	Ceramic Capacitor, 25V, X7R	0805	muRata	GRM21BR71E225KA73L
1	D1	B0530	Diode Schottky	SOD-123	Diodes Inc.	B0530W
1	L1	2uH	Inductor 2.8A	D53LC	TOKO	D53LC-#A915AY-2R0M
1	R1	100Ω	5%	0603	Any	
1	R2	0Ω	5%	0603	Any	
1	R3	1Ω	1%	0805	Yageo	RC0805FR-071RL
1	R4	NS	Not Stuffed			
1	U1	MP3304CDD	MPS WLED Driver	QFN8(2x3mm)	MPS	MP3304CDD-LF-Z

PRINTED CIRCUIT BOARD LAYOUT

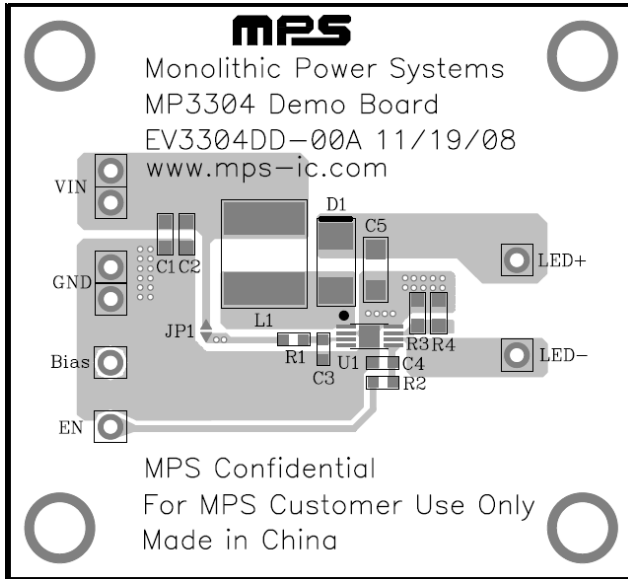

Figure 1—Top Layer

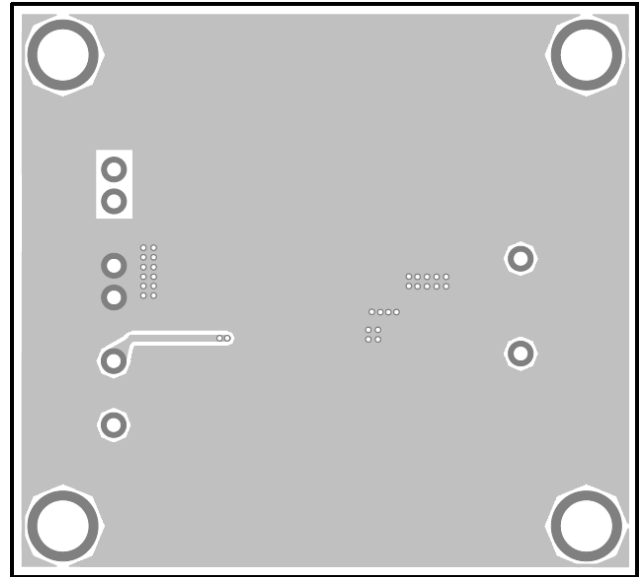

Figure 2—Bottom Layer

QUICK START GUIDE

1. Connect the positive and negative terminals of the load panel (3 white LEDs in series, 10 strings paralleled, each string have a 43ohm droop resistor) to the LED+ and LED- pins on the EV board, respectively.
2. Connect the positive and negative terminals of the power supply (5V) to the VIN and GND pins on the EV board, respectively. Turn the power supply on.
3. Drive EN pin high ($V_{EN} > 2V$) to enable the MP3304.
4. For PWM dimming mode, apply a PWM rectangular waveform with a minimum voltage less than 0.5V and a maximum greater than 2V on EN pin. The frequency of the PWM signal is recommended between 250Hz to 50kHz.

NOTICE: The information in this document is subject to change without notice. Users should warrant and guarantee that third party Intellectual Property rights are not infringed upon when integrating MPS products into any application. MPS will not assume any legal responsibility for any said applications.