

Express-KL2

COM Express Basic Size Type 2 Module with Mobile 7th Gen Intel® Xeon®, and Core™ Processors

Features

- PICMG COM.0 Type 2 compliant module with mainstream processor
- Dual channel DDR4 ECC/non-ECC memory in dual stacked SODIMM sockets
- Single/dual channel 18/24-bit LVDS and VGA
- Six PCIe x1, one PCI, one PCIe x16 (muxed with DDI channel)
- Three SATA, one PATA, eight USB 2.0 and GbE
- Extreme Rugged operating temperature: -40°C to +85°C (selected SKUs)

Specifications

• Core System

CPU

Mobile 7th Generation Intel® Xeon®, and Core™ Processors - 14nm (formerly "Kaby Lake-H")

- Xeon® E3-1505M v6 3.0/4.0GHz (Turbo), 45W(35W cTDP) (4C/GT2)
- Xeon® E3-1505L v6 2.2/3.0GHz (Turbo), 25W (4C/GT2)
- Core™ i7-7820EQ 3.0/3.7GHz (Turbo), 45W(35W cTDP) (4C/GT2)
- Core™ i5-7440EQ 2.9/3.6GHz (Turbo), 45W(35W cTDP) (4C/GT2)
- Core™ i5-7442EQ 2.1/2.9GHz (Turbo), 25W (4C/GT2)
- Core™ i3-7100E 2.9GHz (no Turbo), 35W (2C/GT2)
- Core™ i3-7102E 2.1GHz (no Turbo), 25W (2C/GT2)

Supports: Intel® VT, Intel® TXT, Intel® SSE4.2, Intel® HT Technology, Intel® 64 Architecture, Execute Disable Bit, Intel® Turbo Boost Technology 2.0, Intel® AVX2, Intel® AES-NI, PCLMULQDQ Instruction, Intel® Device Protection Technology with Intel® Secure Key, Intel® TSXNI

Note: Availability of features may vary between processor SKUs.

Memory

2400 MHz DDR4 memory in dual stacked SODIMM sockets

Note: Xeon® with CM236 supports both ECC and non-ECC memory
(Core™ i3 available with MOQ)

Embedded BIOS

AMI EFI with CMOS backup in 16MB SPI BIOS with Intel® AMT 11 support (depends on CPU/PCH)

Cache

8MB for Xeon®/Core™ i7, 6MB for Core™ i5, 3MB for Core™ i3 and 2MB for Celeron®

PCH

CM238 (supports ECC and non-ECC memory and Intel® AMT)
QM175 (supports Intel® AMT)
HM175 (no Intel® AMT support)

Expansion Busses

PCIe x16 or 2 PCIe x8 or 1 PCIe x8 with 2 PCIe x4 (Gen3, muxed with DDI channel, build option)
6 PCI Express x1 (Gen3); AB connector, Lanes 0/1/2/3/4/5, supports x4, x2, x1 configurations
1 PCI bus
LPC bus, SMBus (system), I²C (user)

SEMA Board Controller

Supports: Voltage/current monitoring, power sequence debug support, AT/ATX mode control, logistics and forensic information, flat panel control, general purpose I2C, failsafe BIOS (dual BIOS), watchdog timer and fan control

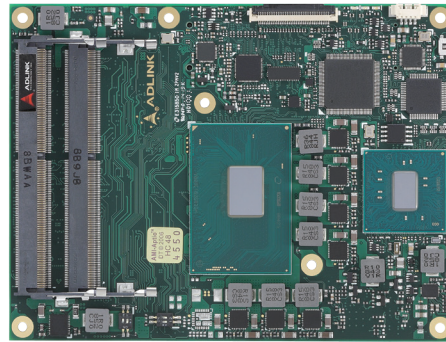

Debug Headers

40-pin multipurpose flat cable connector for use with DB-40 debug module providing BIOS POST code LED, BMC access, SPI BIOS flashing, power testpoints, debug LEDs

• Video

GPU Feature Support

Intel® Generation 9 Graphics Core Architecture, supporting 3 independent and simultaneous display combinations of VGA, LVDS (or optional eDP), optional DisplayPort/HDMI outputs (DisplayPort/HDMI from DDI channel muxed with PEG port)

- Encode/transcode HD content
- Playback of high definition content including Blu-ray Disc
- Playback of Blu-ray Disc 3D content using HDMI (1.4a spec compliant with 3D)
- DirectX Video Acceleration (DXVA) support for accelerated video processing
- HEVC/H.265, H.264, M/JPEG, MPEG2, VC1, WMV9, VP8/VP9 HW decode
- HEVC/H.265, M/JPEG, MPEG2 HW encode
- Advanced Scheduler 2.0, 1.0, XPDM support
- DirectX 12, DirectX 11.3, DirectX 11, DirectX 10.1, DirectX 10, DirectX 9 support
- OpenGL up to 4.4, OpenCL up to 2.1 support

Digital Display Interface

DDI1/2 are muxed with PEG port, build option feature, supporting DisplayPort 1.2, HDMI 1.4, DVI

Notes:

DP1.2: max. resolution 4096x2304 @ 60Hz, 24bpp

HDMI 1.4: max. resolution 4096x2160 @ 24Hz, 24bpp

VGA

VGA support from DP-to-VGA IC

LVDS

Single/dual channel 18/24-bit LVDS from eDP-to-LVDS IC (max. resolution 1920x1200@60Hz in dual mode)

eDP

4 lane support optional, in place of LVDS (build option, max. resolution 4096x2304 @ 60Hz, 24bpp)

Specifications

• Audio

Chipset

Intel® HD Audio integrated in chipset

Audio Codec

Located on carrier Express-BASE

• Ethernet

Integrated MAC

MAC integrated in QM170/HM170/CM236 Chipset

Intel® PHY

Intel® I219LM/V with AMT 11.0 support (only LM version supports AMT)

Interface

10/100/1000 GbE connection

• Multi I/O and Storage

USB: 8x USB 2.0 (USB 0-7)

SATA: 3x SATA 6Gb/s (SATA 0,1,2) Max. 4x SATA without PATA feature, build option

IDE (PATA): SATA-to-PATA IC on SATA port 3, Master only

GPIO/SD: 4x GPO and 4x GPI (GPI with interrupt)

• Super I/O

Supported on carrier if needed (standard support for W83627DHG-P)

• TPM

Chipset: Infineon

Type: TPM 2.0

• Power

Standard Input: ATX 12V±5% / 5Vsb ±5% or AT 12V±5%

Wide Input: ATX 8.5-20 V / 5Vsb ±5% or AT 8.5-20V

Management: ACPI 5.0 compliant, Smart Battery support

Power States: C1-C6, S0, S3, S4, S5, S5 ECO mode (Wake-on-USB S3/S4, WOL S3/S4/S5)

ECO mode: Supports deep S5 mode for power saving

• Mechanical and Environmental

Form Factor: PICMG COM.0, Rev 2.1 Type 2

Dimension: Basic size: 125 mm x 95 mm

Operating Temperature

Standard: 0°C to 60°C

Extreme Rugged: -40°C to 85°C (selected SKUs, by project basis)

Humidity

5-90% RH operating, non-condensing

5-95% RH storage (and operating with conformal coating)

Shock and Vibration

IEC 60068-2-64 and IEC-60068-2-27

MIL-STD-202F, Method 213B, Table 213-I, Condition A and Method 214A, Table 214-I, Condition D

HALT

Thermal Stress, Vibration Stress, Thermal Shock and Combined Test

• Operating Systems

Standard Support

Windows 10 (64-bit), Linux (64-bit), VxWorks

Extended Support (BSP)

Linux 64-bit, VxWorks

Functional Diagram

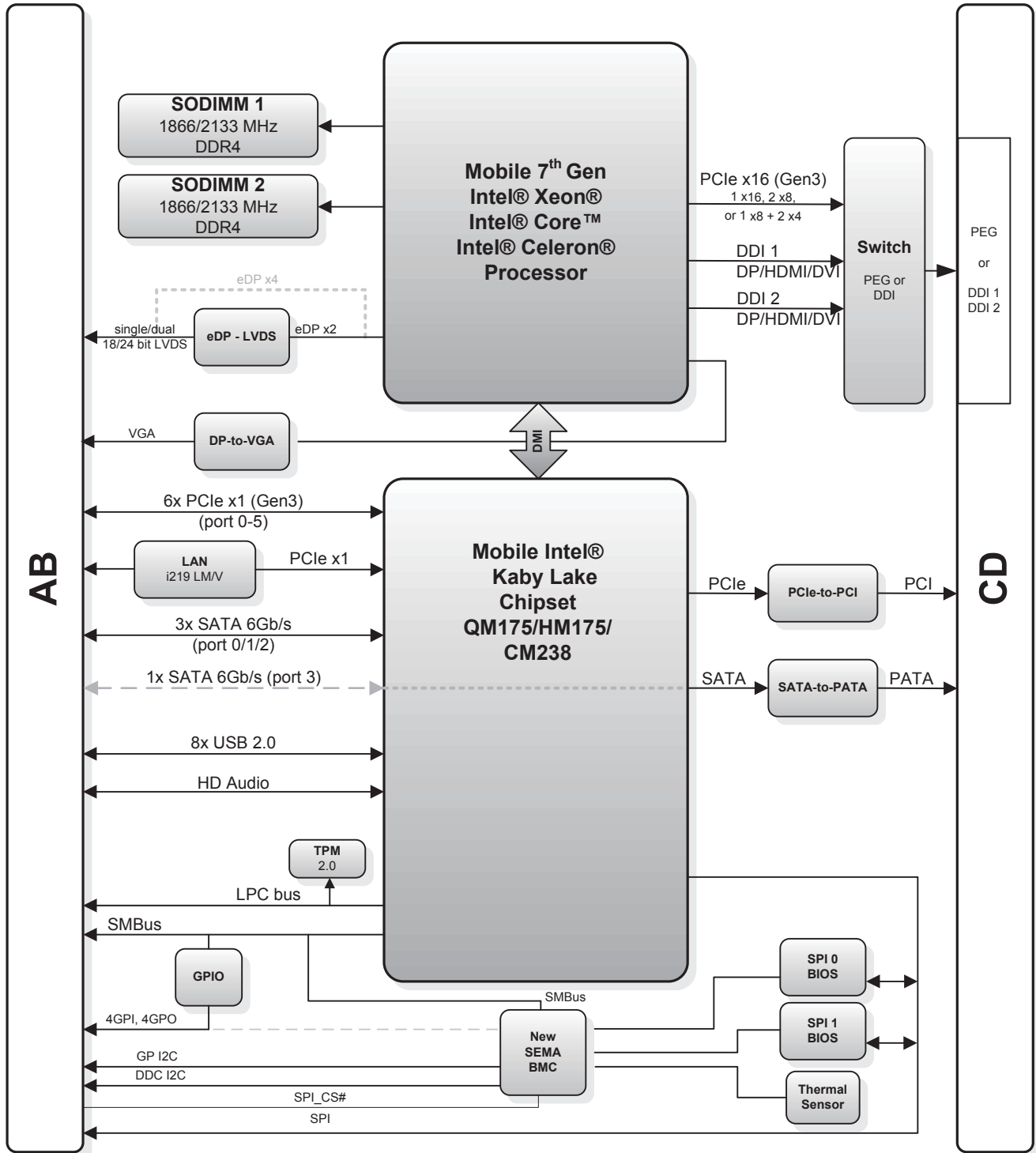

Ordering Information

- **Express-KL2-i7-7820EQ**
Basic Size COM Express® Type 2 module with Intel® Core™ i7-7820EQ and GT2 level graphics, QM175 chipset
- **Express-KL2-i5-7440EQ**
Basic Size COM Express® Type 2 module with Intel® Core™ i5-7440EQ and GT2 level graphics, QM175 chipset
- **Express-KL2-i3-7100E**
Basic Size COM Express® Type 2 module with Intel® Core™ i3-7100E and GT2 level graphics, HM175 chipset

Accessories

Heat Spreaders

- **HTS-SL2-B**
Heatspreader for Express-SL2 with threaded standoffs for bottom mounting

Passive Heatsinks

- **THS-SL2-B**
Low profile heatsink for Express-SL2 with threaded standoffs for bottom mounting
- **THSH-SL2-B**
High profile heatsink for Express-SL2 with threaded standoffs for bottom mounting

Active Heatsink

- **THSF-SL2-B**
High profile heatsink for Express-SL2 with threaded standoffs for top mounting

Notes: Express-SL2, Express-KL2 share the same thermal solutions

Starter Kit

COM Express Type 2

- **Starter Kit Plus**
Starter kit for COM Express Type 2

Notes:

- * All specifications are subject to change without further notice.
- * For CPU and chipset combinations not listed, please contact your ADLINK representative for availability.