

Remote I/O R7I4D Series

EtherCAT I/O MODULE

(high-speed DC voltage input, 8 points, non-isolated, e-CON connector)

Functions & Features

- 8 points high-speed DC voltage input module for EtherCAT
- Easy parameter setting of individual channels with M-System's configurator software

EtherCAT® is a registered trademark and patented technology, licensed by Beckhoff Automation GmbH, Germany.

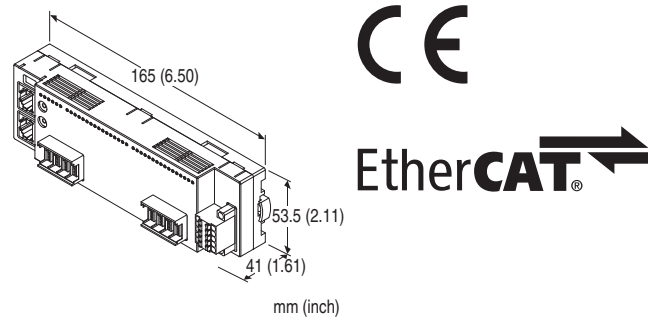

MODEL: R7I4DECT-1-SVF8N-R[1]

ORDERING INFORMATION

- Code number: R7I4DECT-1-SVF8N-R[1]
- Specify a code from below for [1].
(e.g. R7I4DECT-1-SVF8N-R/Q)
- Specify the specification for option code /Q
(e.g. /C01/SET)

TERMINAL BLOCK

- 1: Tension clamp terminal block for power supply
 RJ-45 Modular jack for communication
 e-CON connector for I/O

I/O TYPE

SVF8N: DC voltage input, high-speed, 8 points (non-isolated)

POWER INPUT

DC Power

R: 24 V DC

(Operational voltage range 24 V ±10 %, ripple 10 %p-p max.)

[1] OPTIONS

blank: none

/Q: With options (specify the specification)

SPECIFICATIONS OF OPTION: Q (multiple selections)

COATING (For the detail, refer to M-System's web site.)

/C01: Silicone coating

/C02: Polyurethane coating

/C03: Rubber coating

EX-FACTORY SETTING

/SET: Preset according to the Ordering Information Sheet
(No. ESU-7779-SVF8N)

RELATED PRODUCTS

- PC configurator software (model: R7CFG)
- ESI file

The configurator software and ESI files are downloadable at M-System's web site.

Use a commercially available Mini-B USB cable to connect the unit to a PC.

GENERAL SPECIFICATIONS

Connection

EtherCAT: RJ-45 Modular Jack

Power: Separable screwless spring terminal

Input: e-CON connector

Housing material: Flame-resistant resin (gray)

Isolation: Input to EtherCAT or FE to power

Zero adjustments: Configurable via R7CFG

Span adjustments: Configurable via R7CFG

Input range: Configurable via R7CFG

Number of times of averaging: Configurable via R7CFG

Status indicator LED: PWR, RUN, ERR, L/A IN, L/A OUT

(Refer to the instruction manual.)

EtherCAT COMMUNICATION

Standard: IEEE 802.3u

Transmission type: 100BASE-TX

Transmission speed: Full-duplex 100 Mbps

Transmission media: 100BASE-TX (STP cable; Category 5e)

Maximum internode length: 100 meters

Fixed address: Set with rotary switches

(The master must support MDP.)

INPUT SPECIFICATIONS

Input resistance: ≥ 1 MΩ

Input range: -10 - +10 V DC, -5 - +5 V DC, 0 - 10 V DC,
0 - 5 V DC, 1 - 5 V DC

INSTALLATION

Current consumption: Approx. 40 mA (rated current 8 A)
Operating temperature: -10 to +55°C (14 to 131°F)
Storage temperature: -20 to +65°C (-4 to +149°F)
Operating humidity: 30 to 90 %RH (non-condensing)
Atmosphere: No corrosive gas or heavy dust
Mounting: Surface or DIN rail (35 mm rail)
Weight: 170 g (0.37 lb)

PERFORMANCE

Conversion accuracy: $\pm 0.1\%$
Conversion rate: 2.5 msec. / 8 channels
Data range: 0 - 10000 of the input range
Temp. coefficient: $\pm 0.015\%/^{\circ}\text{C}$ ($\pm 0.008\%/^{\circ}\text{F}$)
Input delay time: ≤ 10 msec. (0 - 90 %)
Insulation resistance: $\geq 100\ \text{M}\Omega$ with 500 V DC
Dielectric strength: 1500 V AC @ 1 minute
 (input to EtherCAT or FE to power)

STANDARDS & APPROVALS

EU conformity:

EMC Directive
 EMI EN 61000-6-4
 EMS EN 61000-6-2
 RoHS Directive
 EN 50581

PC CONFIGURATOR

The following parameters can be set with using PC Configurator Software (model: R7CFG)
 Refer to the users manual for the R7CFG for detailed operation of the software program.

■ CHANNEL INDIVIDUAL SETTING

PARAMETER	SETTING RANGE	DEFAULT
Unused setting	CH enable, CH disable	CH enable
Input range	-10 to +10 V DC -5 to +5 V DC 0 to 10 V DC 0 to 5 V DC 1 to 5 V DC	-10 to +10 V DC
Bias setting	-320.00 to +320.00 (%)	0.00 (%)
Gain setting	-3.2000 to +3.2000	1.0000
Zero scaling value	-32000 to +32000	0
Full scaling value	-32000 to +32000	10000

■ CHANNEL BATCH SETTING

PARAMETER	SETTING RANGE	DEFAULT
No. of moving average	1, 2, 4, 8, 16, 32, 64, 128	1

EXTERNAL VIEW

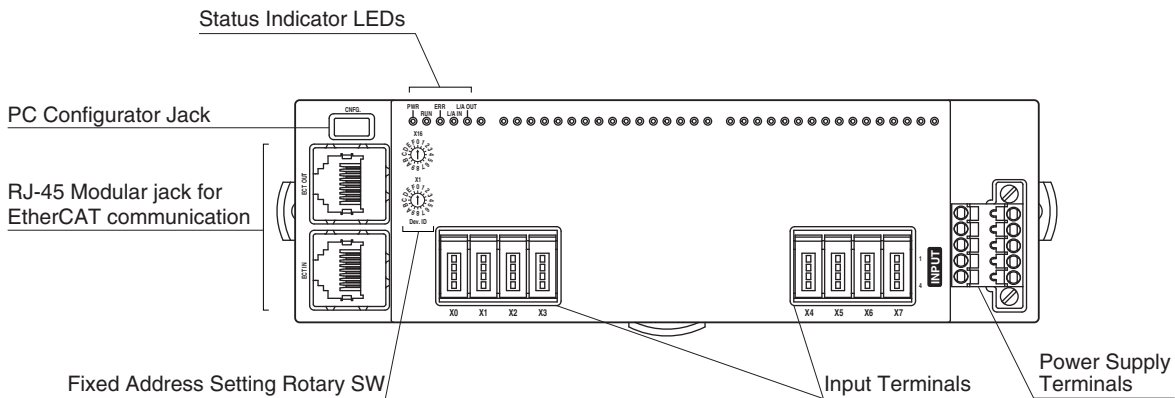

TERMINAL ASSIGNMENTS

■ INPUT TERMINAL ASSIGNMENT

• e-CON connector

Recommended cable connector: 37104-()-000FL (3M Company)

(The cable connector is not included in the package.)

Specify wire size instead of (); refer to the specifications of the product.)

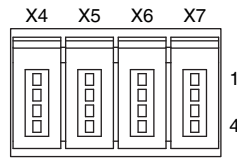
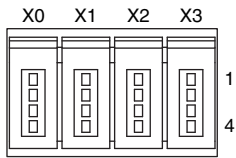

PIN No.	ID	FUNCTION	PIN No.	ID	FUNCTION
X0	1	NC	X4	1	NC
	2	COM		2	COM
	3	NC		3	NC
	4	VH0		4	VH4
X1	1	NC	X5	1	NC
	2	COM		2	COM
	3	NC		3	NC
	4	VH1		4	VH5
X2	1	NC	X6	1	NC
	2	COM		2	COM
	3	NC		3	NC
	4	VH2		4	VH6
X3	1	NC	X7	1	NC
	2	COM		2	COM
	3	NC		3	NC
	4	VH3		4	VH7

■ POWER SUPPLY

Cable connector: TFMC1,5 / 5-STF-3,5
(Phoenix Contact) (included in the package)

Applicable wire size: 0.2 – 1.5 mm²; stripped length 10 mm

Recommended solderless terminal

- AI0,25–10YE 0.25 mm² (Phoenix Contact)
- AI0,34–10TQ 0.34 mm² (Phoenix Contact)
- AI0,5–10WH 0.5 mm² (Phoenix Contact)
- AI0,75–10GY 0.75 mm² (Phoenix Contact)
- A1–10 1.0 mm² (Phoenix Contact)
- A1,5–10 1.5 mm² (Phoenix Contact)

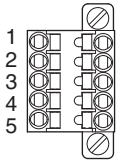

- | | |
|---------|------------------|
| 1. PWR+ | Power Supply |
| 2. PWR- | Power Supply |
| 3. FE | Functional earth |
| 4. NC | Unused |
| 5. NC | Unused |

Note: The numbers marked on the connector have no relationship to the pin number of the unit.
Wire according to the instruction manual of the unit.

RESPONSE TIME

- Input module

Response time is time from when a step (0 to 100%) input signal is applied to the input module (slave) until when output from its communication CPU reaches 90% of the final value.

T_{COM} : EtherCAT communication cycle set by the host device (master)
(The cycle is determined in accordance with the system configuration and settings.)

T_{INP} : Input module response time \leq Delay time of input circuit (T_a) + Conversion speed^{*1} (T_b) + Input internal processing time (T_c) (Communication cycle x 2)

*1. Conversion speed x No. of moving averages (1 to 128)

ex.) When No. of moving averages: 1 and EtherCAT communication cycle: 1 msec.,
Input module response time (T_{INP}): Delay time of input circuit (10 msec.) + Conversion speed (2.5 msec.) x No. of moving averages (1) + Input internal processing time (1 msec. x 2) = 14.5 [msec.]

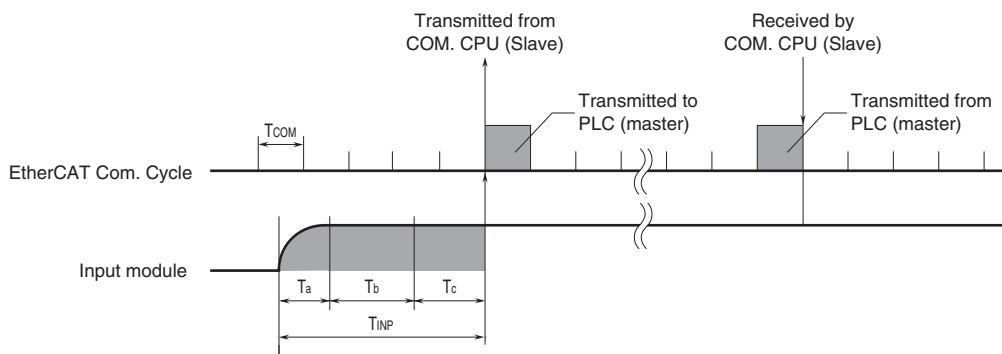

I/O DATA DESCRIPTIONS

Scaling of analog input module is configurable with the configurator software (model: R7CFG). Refer to the software manual for details.

ANALOG INPUT MODULE

Input Area Objects



16 bit binary data

Negative values are represented by 2's complements.

STATUS (Input Area Object)

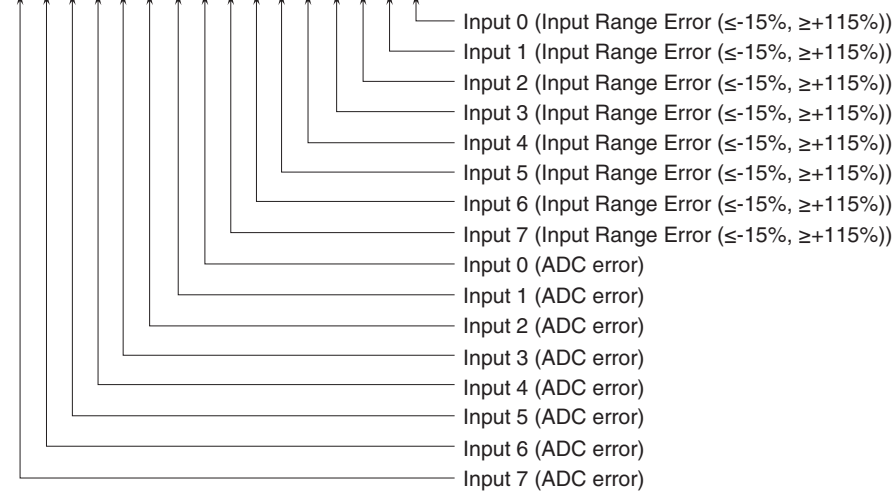

Input Range Error

0 : Normal 1 : Error

ADC error (no response from ADC)

0 : Normal 1 : Error

EXTERNAL DIMENSIONS unit: mm (inch)

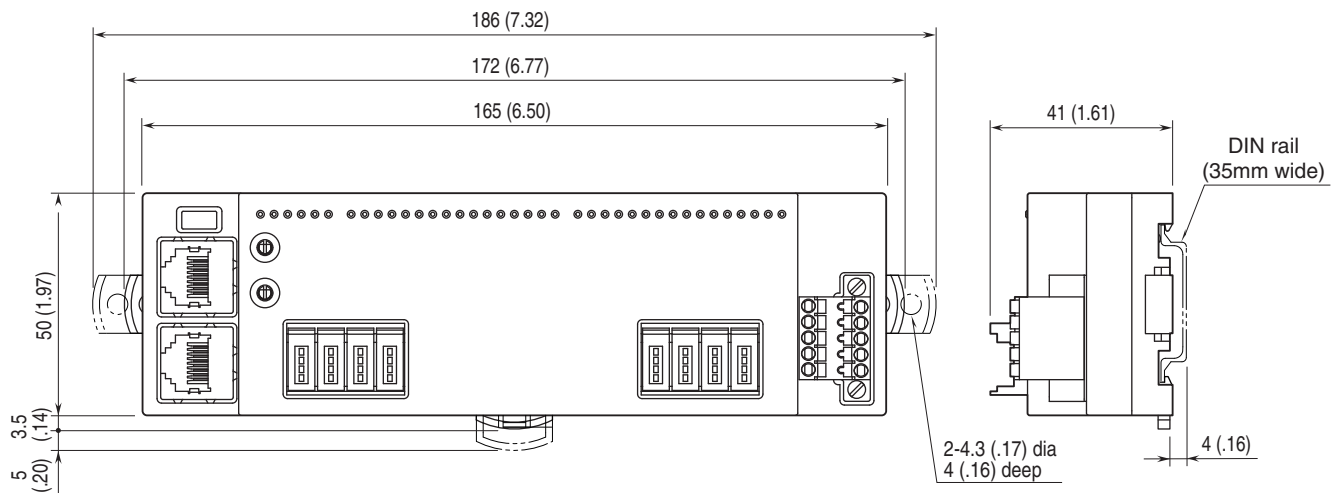

MOUNTING REQUIREMENTS unit: mm (inch)

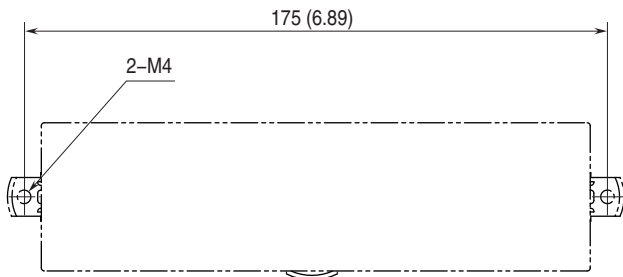

SCHEMATIC CIRCUITRY & CONNECTION DIAGRAM

Note: In order to improve EMC performance, bond the FE terminal to ground.

Caution: FE terminal is NOT a protective conductor terminal.

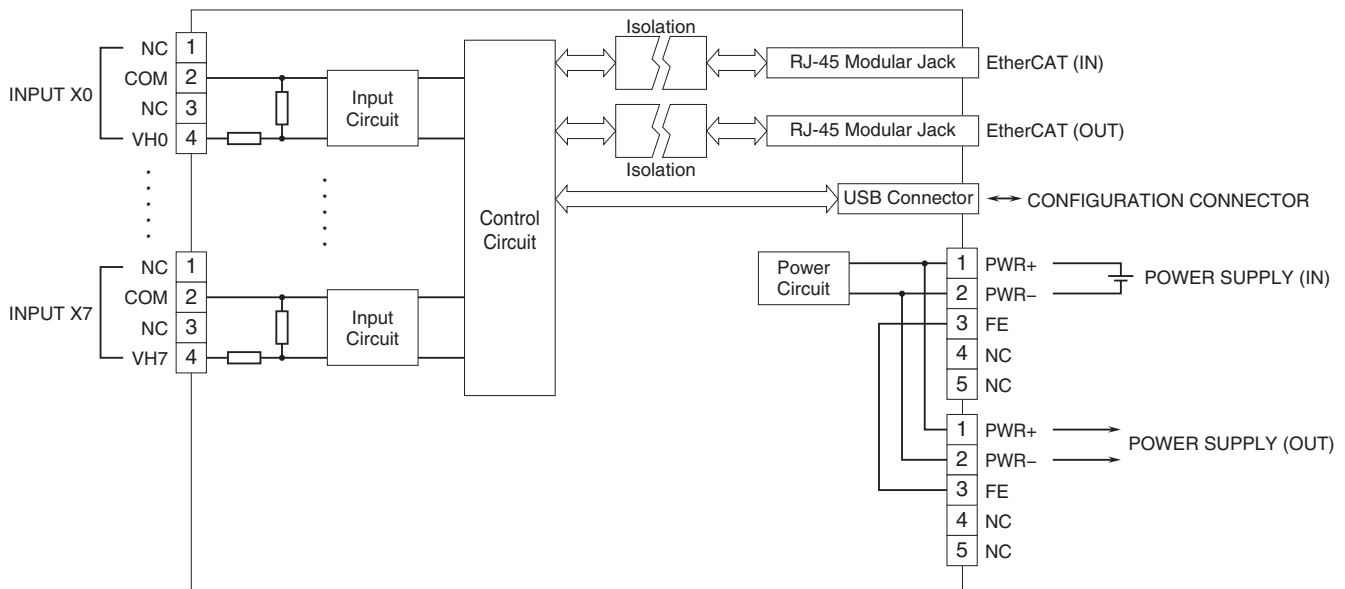

Specifications are subject to change without notice.