

Mobile Multimedia CODEC with Dual-Mode Class AB/D Speaker Driver

DESCRIPTION

The WM8991 is a highly integrated ultra-low power hi-fi codec designed for handsets rich in multimedia features such as mobile TV, digital audio playback and gaming. Ultra-low power and low noise interfaces to many other audio components in the system are provided.

A powerful 1W speaker driver can operate in class D or AB modes, providing total flexibility to the system designer. Low leakage, high PSRR and pop/click suppression enable direct battery connection for the speaker supply.

A very highly flexible input configuration supports multiple microphone or line inputs (mono or stereo, single-ended or differential).

Four headphone drivers support fully differential headset drive, providing excellent crosstalk performance and bass response, maximising stereo effects, and allowing the removal of large and expensive headphone capacitors.

Stereo 24-bit sigma-delta ADCs and DACs provide hi-fi quality audio record and playback, with a flexible digital audio interface supporting most commonly-used clocking schemes. An integrated low power PLL, an alternative DAC interface and TDM support provide additional flexibility.

The WM8991 is supplied in very small and thin 5x5mm 65-ball BGA package, ideal for use in portable systems.

FEATURES

DAC SNR 99dB ('A' weighted), THD -84dB at 48kHz, 3.3V
 ADC SNR 94dB ('A' weighted), THD -82dB at 48kHz, 3.3V
 Microphone interface (Up to four differential microphones)

1W Speaker driver

- 1W into 8Ω BTL speaker at <0.1% THD
- 80dB PSRR @217Hz
- <1uA leakage with direct battery connection
- Software-selectable class D or AB mode
- Filterless connection supported
- Pop/Click suppression

Headphone / ear speaker drivers

- 40mW output power into 16Ω at 3.3V
- Fully differential and capless modes supported
- Pop/Click suppression

4 Mono or stereo differential line outputs

Powerful GPIO functions

Ultra-low power consumption

- 8.3mW analogue voice call
- 13.7mW DAC playback to headphones

On-chip PLL provides flexible clocking scheme

Sample rates: 8, 11.025, 12, 16, 22.05, 24, 32, 44.1, 48kHz

65-ball 5x5mm BGA package

APPLICATIONS

Multimedia phones
 GPS

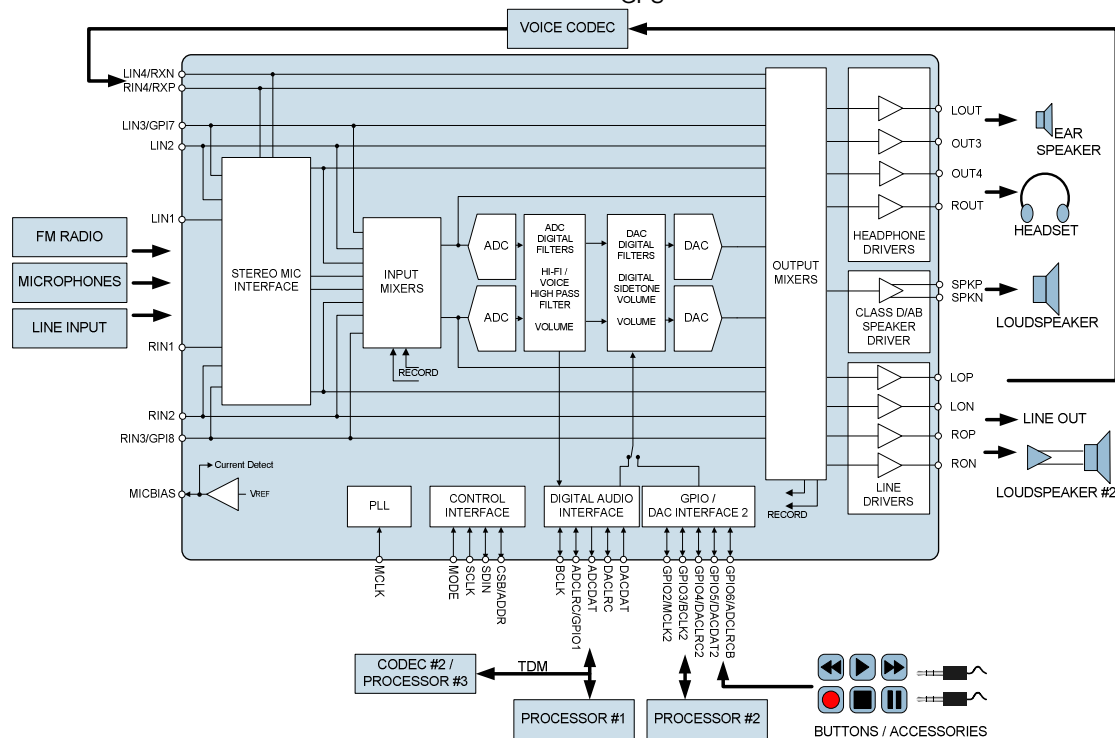
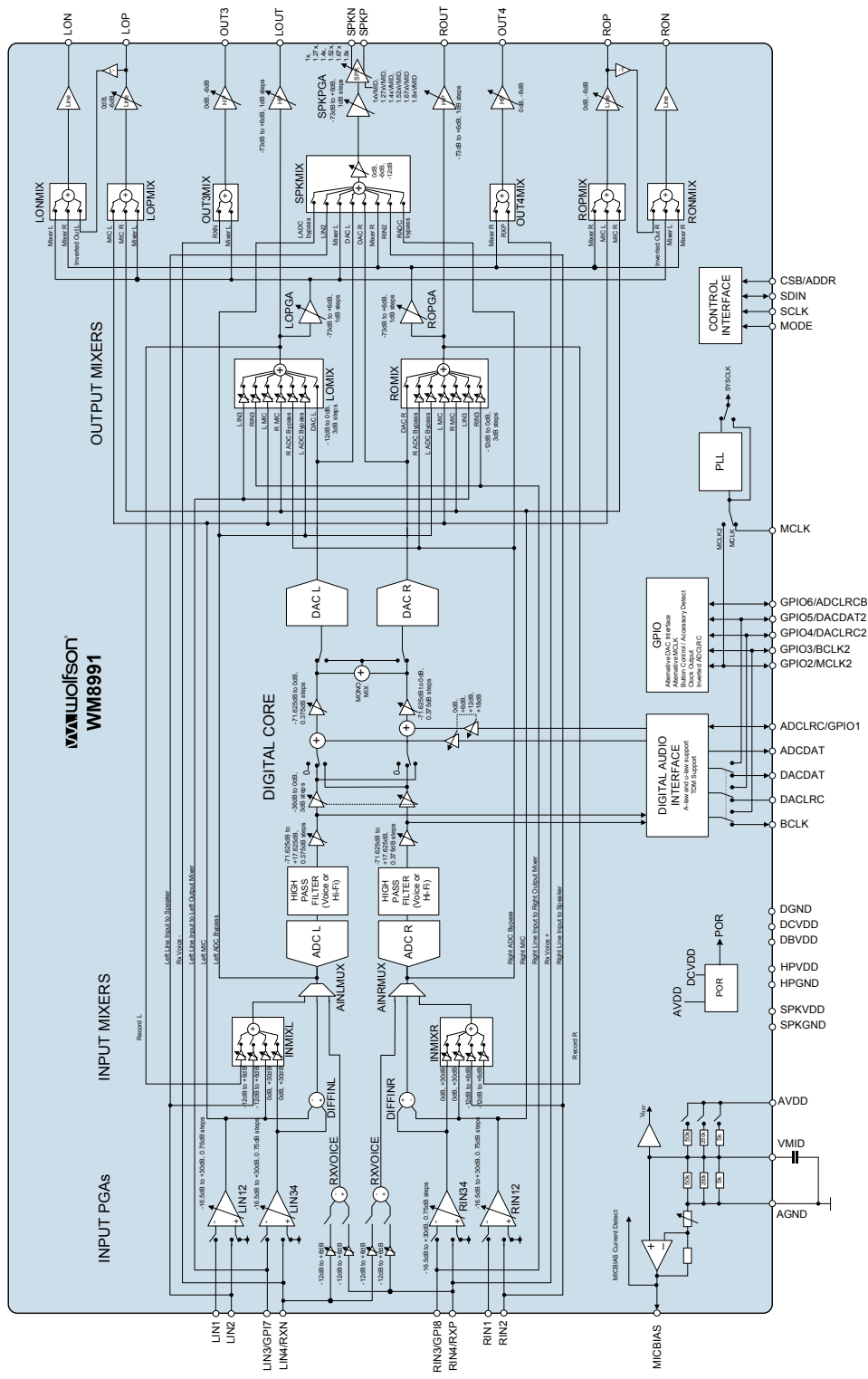

TABLE OF CONTENTS

DESCRIPTION	1
FEATURES.....	1
APPLICATIONS	1
TABLE OF CONTENTS	2
BLOCK DIAGRAM	4
PIN CONFIGURATION.....	5
ORDERING INFORMATION	5
PIN DESCRIPTION	6
ABSOLUTE MAXIMUM RATINGS.....	8
RECOMMENDED OPERATING CONDITIONS	8
SPEAKER POWER DE-RATING CURVE.....	10
ELECTRICAL CHARACTERISTICS	12
TYPICAL POWER CONSUMPTION	24
SPEAKER DRIVER PERFORMANCE	25
HEADPHONE DRIVER PERFORMANCE.....	25
PSRR PERFORMANCE.....	26
AUDIO SIGNAL PATHS.....	28
SIGNAL TIMING REQUIREMENTS	29
SYSTEM CLOCK TIMING.....	29
TEST CONDITIONS	29
AUDIO INTERFACE TIMING – MASTER MODE.....	30
AUDIO INTERFACE TIMING – SLAVE MODE	31
AUDIO INTERFACE TIMING – TDM MODE	32
CONTROL INTERFACE TIMING – 2-WIRE MODE.....	33
CONTROL INTERFACE TIMING – 3-WIRE MODE.....	34
CONTROL INTERFACE TIMING – 4-WIRE MODE.....	35
INTERNAL POWER ON RESET CIRCUIT	36
DEVICE DESCRIPTION	38
INTRODUCTION.....	38
INPUT SIGNAL PATH.....	39
ANALOGUE TO DIGITAL CONVERTER (ADC)	54
DIGITAL MIXING	57
DIGITAL TO ANALOGUE CONVERTER (DAC)	61
OUTPUT SIGNAL PATH.....	65
ANALOGUE OUTPUTS	76
THERMAL SHUTDOWN.....	81
GENERAL PURPOSE INPUT/OUTPUT	82
DIGITAL AUDIO INTERFACE.....	101
DIGITAL AUDIO INTERFACE CONTROL	113
CLOCKING AND SAMPLE RATES	119
CONTROL INTERFACE	127
POWER MANAGEMENT	131
POP SUPPRESSION CONTROL.....	134
POWER DOMAINS.....	139
REGISTER MAP.....	140
REGISTER BITS BY ADDRESS.....	142
DIGITAL FILTER CHARACTERISTICS	166
ADC FILTER RESPONSES	167

ADC HIGH PASS FILTER RESPONSES	167
DAC FILTER RESPONSES	168
DE-EMPHASIS FILTER RESPONSES	169
APPLICATIONS INFORMATION	170
RECOMMENDED EXTERNAL COMPONENTS.....	170
PACKAGE DIMENSIONS	173
IMPORTANT NOTICE	174
ADDRESS:.....	174

BLOCK DIAGRAM



PIN CONFIGURATION

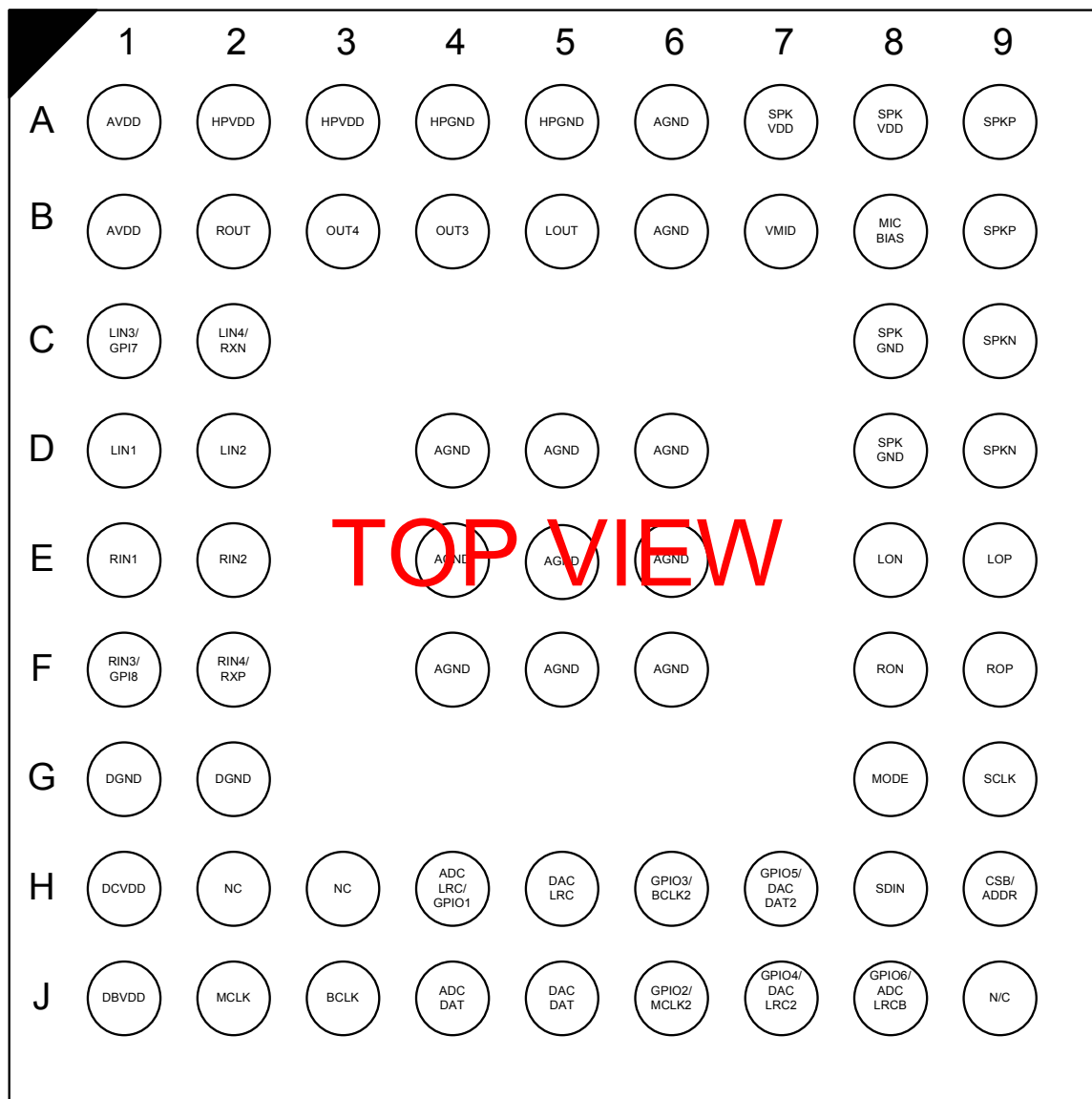

ORDERING INFORMATION

ORDER CODE	TEMPERATURE RANGE	PACKAGE	MOISTURE SENSITIVITY LEVEL	PEAK SOLDERING TEMPERATURE
WM8991GEB/V	-40°C to +85°C	65-ball BGA (Pb-free)	MSL3	260°C
WM8991GEB/RV	-40°C to +85°C	65-ball BGA (Pb-free, Tape and reel)	MSL3	260°C

Note:

Reel quantity = 3500

PIN DESCRIPTION

PIN NO	NAME	TYPE	DESCRIPTION
B8	MICBIAS	Analogue Output	Microphone bias
D1	LIN1	Analogue Input	Left channel single-ended MIC input / Left channel negative differential MIC input
D2	LIN2	Analogue Input	Left channel line input / Left channel positive differential MIC input
C1	LIN3 / GPI7	Analogue Input / Digital Input	Left channel line input / Left channel negative differential MIC input / Accessory or button detect input pin
C2	LIN4 / RXN	Analogue Input	Left channel line input / Left channel positive differential MIC input / Mono differential negative input (Rx voice -)
E1	RIN1	Analogue Input	Right channel single-ended MIC input / Right channel negative differential MIC input
E2	RIN2	Analogue Input	Right channel line input / Right channel positive differential MIC input
F1	RIN3 / GPI8	Analogue Input / Digital Input	Right channel line input / Right channel negative differential MIC input / Accessory or button detect input pin
F2	RIN4 / RXP	Analogue Input	Left channel line input / Left channel positive differential MIC input / Mono differential positive input (Rx voice +)
H1	DCVDD	Supply	Digital core supply
G1	DGND	Supply	Digital ground (Return path for both DCVDD and DBVDD)
G2			
J1	DBVDD	Supply	Digital buffer (I/O) supply
A1	AVDD	Supply	Analogue supply
B1			
A6	AGND	Supply	Analogue ground (Return path for AVDD)
B6			
D4			Note: D4 to F6 are GND_PADDLES for thermal conduction and must be connected on the PCB for thermal reasons.
D5			
D6			
E4			
E5			
E6			
F4			
F5			
F6			
A2	HPVDD	Supply	Headphone supply
A3			
A4	HPGND	Supply	Headphone ground (Return path for HPVDD)
A5			
A7	SPKVDD	Supply	Supply for speaker driver
A8			
C8	SPKGND	Supply	Ground for speaker driver (Return path from SPKVDD)
D8			
J2	MCLK	Digital Input	Master clock
J3	BCLK	Digital Input / Output	Audio interface bit clock
H5	DACLRC	Digital Input / Output	Audio interface DAC left / right clock
J5	DACDAT	Digital Input	DAC digital audio data
H4	ADCLRC / GPIO1	Digital Input / Output	Audio interface ADC left / right clock / GPIO1 pin
J4	ADCDAT	Digital Output	ADC digital audio data

PIN NO	NAME	TYPE	DESCRIPTION
G8	MODE	Digital Input	Selects 2-wire or 3/4 -wire control
H9	CSB / ADDR	Digital Input	3/4 -wire chip select or 2-wire address select
G9	SCLK	Digital Input	Control interface clock input
H8	SDIN	Digital Input / Output	Control interface data input / 2-wire acknowledge output
A9 B9	SPKP	Analogue Output	Speaker positive output
C9 D9	SPKN	Analogue Output	Speaker negative output
B5	LOUT	Analogue Output	Left headphone output
B2	ROUT	Analogue Output	Right headphone output
B4	OUT3	Analogue Output	Inverted left headphone output / Mono inverted output
B3	OUT4	Analogue Output	Inverted right headphone output / Mono non-inverted output
E8	LON	Analogue Output	Negative left line output / Positive right line output
E9	LOP	Analogue Output	Positive left line output
F8	RON	Analogue Output	Negative right line output / Positive left line output
F9	ROP	Analogue Output	Positive right line output
B7	VMID	Analogue Output	Mid-rail voltage decoupling capacitor
J6	GPIO2 / MCLK2	Digital Input / Output	Alternative MCLK / GPIO pin
H6	GPIO3 / BCLK2	Digital Input / Output	Alternative BCLK / GPIO pin
J7	GPIO4 / DACLR2	Digital Input / Output	Alternative DACLR / GPIO pin
H7	GPIO5 / DACDAT2	Digital Input / Output	Alternative DACDAT / GPIO pin
J8	GPIO6 / ADCLRCB	Digital Input / Output	Inverted ADCLR / GPIO pin
H2 H3 J9	NC	Not connected	

ABSOLUTE MAXIMUM RATINGS

Absolute Maximum Ratings are stress ratings only. Permanent damage to the device may be caused by continuously operating at or beyond these limits. Device functional operating limits and guaranteed performance specifications are given under Electrical Characteristics at the test conditions specified.



ESD Sensitive Device. This device is manufactured on a CMOS process. It is therefore generically susceptible to damage from excessive static voltages. Proper ESD precautions must be taken during handling and storage of this device.

Wolfson tests its package types according to IPC/JEDEC J-STD-020B for Moisture Sensitivity to determine acceptable storage conditions prior to surface mount assembly. These levels are:

MSL1 = unlimited floor life at <30°C / 85% Relative Humidity. Not normally stored in moisture barrier bag.

MSL2 = out of bag storage for 1 year at <30°C / 60% Relative Humidity. Supplied in moisture barrier bag.

MSL3 = out of bag storage for 168 hours at <30°C / 60% Relative Humidity. Supplied in moisture barrier bag.

The Moisture Sensitivity Level for each package type is specified in Ordering Information.

CONDITION	MIN	MAX
Supply voltages (excluding SPKVDD)	-0.3V	+4.5V
SPKVDD	-0.3V	+7V
Voltage range digital inputs	DGND -0.3V	DBVDD +0.3V
Voltage range analogue inputs	AGND -0.3V	AVDD +0.3V
Operating temperature range, T _A	-40°C	+85°C
Junction temperature, T _{JMAX}	-40°C	+150°C
Storage temperature after soldering	-65°C	+150°C

RECOMMENDED OPERATING CONDITIONS

PARAMETER	SYMBOL	MIN	TYP	MAX	UNIT
Digital supply range (Core)	DCVDD	1.71		3.6	V
Digital supply range (Buffer)	DBVDD	1.71		3.6	V
Analogue supplies range	AVDD, HPVDD	2.7		3.6	V
Speaker supply range	SPKVDD	2.7		5.5	V
Ground	DGND, AGND, HPGND, SPKGND		0		V

Notes

- Analogue, digital and speaker grounds must always be within 0.3V of each other.
- All digital and analogue supplies are completely independent from each other (i.e. not internally connected).
- DCVDD must be less than or equal to AVDD.
- DCVDD must be less than or equal to DBVDD.
- AVDD must be less than or equal to SPKVDD.
- SPKVDD must be high enough to support the peak output voltage when using DCGAIN and ACGAIN functions, to avoid output waveform clipping. Peak output voltage is $AVDD \cdot (DCGAIN + ACGAIN) / 2$.
- HPVDD must be equal to AVDD

THERMAL PERFORMANCE

Thermal analysis should be performed in the intended application to prevent the WM8991 from exceeding maximum junction temperature. Several contributing factors affect thermal performance most notably the physical properties of the mechanical enclosure, location of the device on the PCB in relation to surrounding components and the number of PCB layers. Connecting the GND balls through thermal vias and into a large ground plane will aid heat extraction.

Three main heat transfer paths exist to surrounding air as illustrated below in Figure 1:

- Package top to air (radiation).
- Package bottom to PCB (radiation).
- Package balls to PCB (conduction).

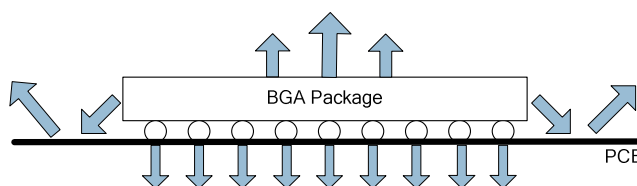

Figure 1 Heat Transfer Paths

The temperature rise T_R is given by $T_R = P_D * \Theta_{JA}$

- P_D is the power dissipated in the device.
- Θ_{JA} is the thermal resistance from the junction of the die to the ambient temperature and is therefore a measure of heat transfer from the die to surrounding air. Θ_{JA} is determined with reference to JEDEC standard JESD51-9.

The junction temperature T_J is given by $T_J = T_A + T_R$, where T_A is the ambient temperature.

PARAMETER	SYMBOL	MIN	TYP	MAX	UNIT
Operating temperature range	T_A	-40		85	°C
Operating junction temperature	T_J	-40		100	°C
Thermal Resistance	Θ_{JA}		57		°C/W

SPEAKER POWER DE-RATING CURVE

The speaker driver has been designed to drive a maximum of 1W into 8Ω with a 5V supply. However, thermal restrictions defined by the BGA package Θ_{JA} limit the amount of power that can be safely dissipated in the device without exceeding the maximum operating junction temperature. Power dissipated in the device correlates directly with speaker efficiency, hence there are separate de-rating curves for class D and class AB operation.

Under no circumstances should the recommended maximum powers be exceeded.

CLASS D DE-RATING CURVES

The de-rating curves shown in Figure 2 are based on a full scale sinusoidal input.

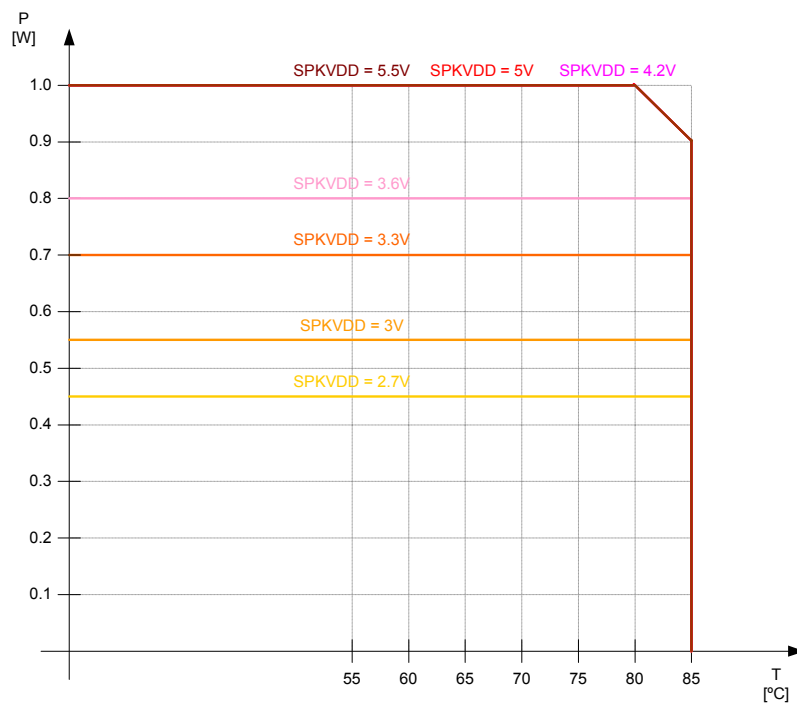

Figure 2 Class D Speaker Power De-Rating Curve

CLASS AB DE-RATING CURVE

The de-rating curves shown in Figure 3 are based on a full scale sinusoidal input

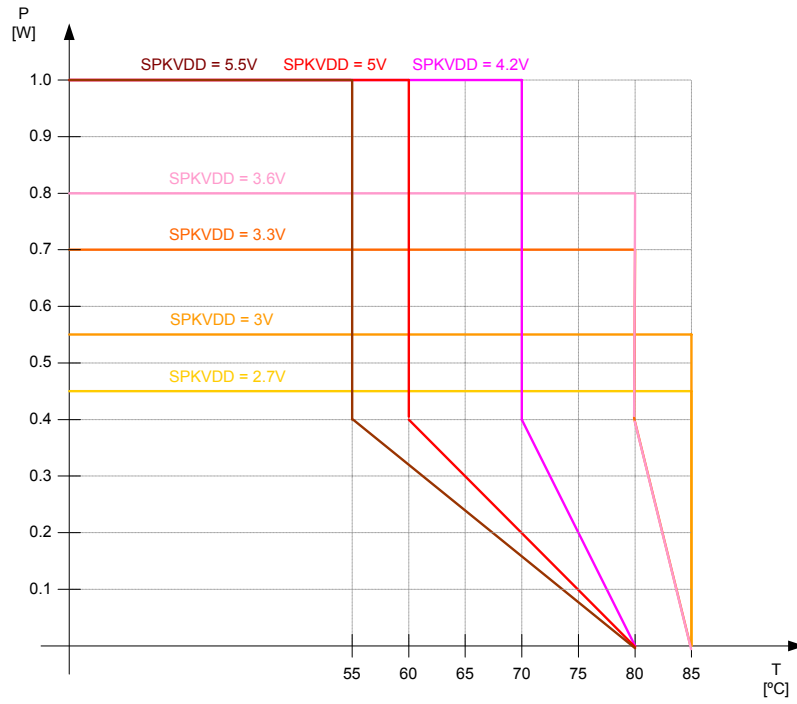

Figure 3 Class AB Speaker Power De-Rating Curve

ELECTRICAL CHARACTERISTICS

Test Conditions

DCVDD = 1.8V, DBVDD = 3.3V, AVDD = HPVDD = 3.3V, SPKVDD = 5V, T_A = +25°C, 1kHz signal, fs = 48kHz, PGA gain = 0dB, 24-bit audio data unless otherwise stated.

PARAMETER	TEST CONDITIONS	MIN	TYP	MAX	UNIT	
Analogue Input Pin Maximum Signal Levels (LIN1, LIN2, LIN3, LIN4, RIN1, RIN2, RIN3, RIN4)						
A1	Maximum Full-Scale PGA Input Signal Level	Single-ended PGA input on LIN1, LIN3, RIN1 or RIN3, output to INMIXL or INMIXR		1.0	0	Vrms dBV
	Note 1: This changes in proportion to AVDD (AVDD/3.3).	Differential PGA input on LIN1/LIN2, LIN3/LIN4, RIN1/RIN2 or RIN3/RIN4, output to INMIXL or INMIXR		1.0	0	Vrms dBV
	Note 2: When mixing input PGA outputs and line inputs the total signal must not exceed 1Vrms (0dBV). Note 3: A 1.0Vrms differential signal equates to 0.5Vrms/-6dBV per input.	Differential input to two single-ended PGA inputs on LIN1/LIN3 or RIN1/RIN3, output to DIFFINL or DIFFINR		1.0	0	Vrms dBV
A2	Maximum Full-Scale Line Input Signal Level	Line input on LIN2, LIN4, RIN2 or RIN4 to INMIXL or INMIXR		1.0	0	Vrms dBV
	Note 1: This changes in proportion to AVDD (AVDD/3.3).	Line input on LIN2 or RIN2 to SPKMIX		1.0	0	Vrms dBV
	Note 2: When mixing line inputs, input PGA outputs and DAC outputs the total signal must not exceed 1Vrms (0dBV).	Line input on LIN3 or RIN3 to LOMIX or ROMIX		1.0	0	Vrms dBV
	Note 3: A 1.0Vrms differential signal equates to 0.5Vrms/-6dBV per input.	Differential mono line input on RXP/RXN to RXVOICE		1.0	0	Vrms dBV
		Differential mono line input on RXP/RXN to differential output on OUT3/OUT4		1.0	0	Vrms dBV

Test Conditions

DCVDD = 1.8V, DBVDD = 3.3V, AVDD = HPVDD = 3.3V, SPKVDD = 5V, T_A = +25°C, 1kHz signal, f_s = 48kHz, PGA gain = 0dB, 24-bit audio data unless otherwise stated.

PARAMETER	TEST CONDITIONS	MIN	TYP	MAX	UNIT	
Analogue Input Pin Impedances (LIN1, LIN2, LIN3, LIN4, RIN1, RIN2, RIN3, RIN4)						
B1	PGA Input Resistance Note: this will be seen in parallel with the resistance of other enabled input paths from the same pin	LIN1, LIN3, RIN1 or RIN3 (PGA Gain = -16.5dB)			57	kΩ
		LIN1, LIN3, RIN1 or RIN3 (PGA Gain = 0dB)			33	kΩ
		LIN1, LIN3, RIN1 or RIN3 (PGA Gain = +30dB)			2	kΩ
		LIN2, LIN4, RIN2 or RIN4 (Constant for all gains)			65	kΩ
B2	Line Input Resistance Note: this will be seen in parallel with the resistance of other enabled input paths from the same pin	LIN2 or RIN2 to INMIXL or INMIXR (-12dB)			60	kΩ
		LIN2 or RIN2 to INMIXL or INMIXR (0dB)			15	kΩ
		LIN2 or RIN2 to INMIXL or INMIXR (+6dB)			7.5	kΩ
		LIN2 or RIN2 to SPKMIX (SPKATTN = 0dB)			20	kΩ
		LIN2 or RIN2 to SPKMIX (SPKATTN = -12dB)			20	kΩ
		LIN3 or RIN3 to LOMIX or ROMIX (0dB)			20	kΩ
		LIN3 or RIN3 to LOMIX or ROMIX (-21dB)			224	kΩ
		RXP and RXN via RXVOICE to AINLMUX or AINRMUX (Gain = +6dB)			7.5	kΩ
		RXP and RXN via RXVOICE to AINLMUX or AINRMUX (Gain = 0dB)			15	kΩ
		RXP and RXN via RXVOICE to AINLMUX or AINRMUX (Gain = -12dB)			45	kΩ
		RXP and RXN via RXVOICE to AINLMUX and AINRMUX (Gain = +6dB)			3.8	kΩ
		RXP and RXN via RXVOICE to AINLMUX and AINRMUX (Gain = 0dB)			7.5	kΩ
		RXP and RXN via RXVOICE to AINLMUX and AINRMUX (Gain = -12dB)			25	kΩ
		LIN4 to OUT3 or RIN4 to OUT4 (Gain = -6dB)			20	kΩ
LIN4 to OUT3 or RIN4 to OUT4 (Gain = 0dB)			20	kΩ		
B3	Input Capacitance	All analogue input pins		10	pF	

Test Conditions

DCVDD = 1.8V, DBVDD = 3.3V, AVDD = HPVDD = 3.3V, SPKVDD = 5V, T_A = +25°C, 1kHz signal, fs = 48kHz,
PGA gain = 0dB, 24-bit audio data unless otherwise stated.

PARAMETER		TEST CONDITIONS	MIN	TYP	MAX	UNIT
Input Programmable Gain Amplifiers (PGAs) LIN12, LIN34, RIN12 and RIN34						
C1	Minimum Programmable Gain			-16.5		dB
C2	Maximum Programmable Gain			30		dB
C3	Programmable Gain Step Size	Guaranteed monotonic		1.5		dB
C4	Mute Attenuation	Inputs disconnected		90		dB
C5	Common Mode Rejection Ratio (1kHz input)	Single PGA in differential mode, gain = +30dB		60		dB
		Single PGA in differential mode, gain = 0dB		50		
		Single PGA in differential mode, gain = -16.5dB		50		
		Differential input to DIFFINL or DIFFINR via LIN1/LIN3 or RIN1/RIN3, gain = 0dB		45		
Received Voice (RXP-RXN) Differential to Single-Ended Converter RXVOICE						
C6	Minimum Programmable Gain	AINLMODE = 01 or AINRMODE = 01		-12		dB
C7	Maximum Programmable Gain	AINLMODE = 01 or AINRMODE = 01		+6		dB
C8	Programmable Gain Step Size	AINLMODE = 01 or AINRMODE = 01		3		dB
C9	Mute Attenuation	AINLMODE = 01 or AINRMODE = 01		95		dB
PGA Output Differential to Single Ended Converters DIFFINL and DIFFINR						
C10	Fixed Gain	AINLMODE = 10 or AINRMODE = 10		0		dB
C11	Mute Attenuation	AINLMODE = 10 or AINRMODE = 10		95		dB
Input Mixers INMIXL and INMIXR						
C12	Minimum Programmable Gain	PGA Outputs to INMIXL and INMIXR		0		dB
C13	Maximum Programmable Gain	PGA Outputs to INMIXL and INMIXR		+30		dB
C14	Programmable Gain Step Size	PGA Outputs to INMIXL and INMIXR		30		dB
C15	Minimum Programmable Gain	Line Inputs and Record path to INMIXL and INMIXR		-12		dB
C16	Maximum Programmable Gain	Line Inputs and Record path to INMIXL and INMIXR		+6		dB
C17	Programmable Gain Step Size	Line Inputs and Record path to INMIXL and INMIXR		3		dB
C18	Mute attenuation			95		dB
Output Programmable Gain Amplifiers (PGAs) SPKPGA, LOPGA, ROPGA, LOU and ROUT						
C19	Minimum Programmable Gain			-73		dB
C20	Maximum Programmable Gain			+6		dB
C21	Programmable Gain Step Size	Guaranteed monotonic		1		dB
C22	Mute attenuation	LOU and ROUT		80		dB
		SPKPGA, LOPGA and ROPGA		70		dB
Output Programmable Gain Amplifiers (PGAs) OUT3, OUT4, LOP and ROP						
C23	Minimum Programmable Gain			-6		dB
C24	Maximum Programmable Gain			0		dB
C25	Programmable Gain Step Size			6		dB
C26	Mute attenuation	OUT3 and OUT4		80		dB
		LOP and ROP (also applies to LON and RON)		100		dB
Speaker Attenuation (SPKATTN)						
C27	Minimum Programmable Gain			-12		dB
C28	Maximum Programmable Gain			0		dB
C29	Programmable Gain Step Size			6		dB
C30	Mute attenuation			80		dB

Test Conditions

DCVDD = 1.8V, DBVDD = 3.3V, AVDD = HPVDD = 3.3V, SPKVDD = 5V, T_A = +25°C, 1kHz signal, f_s = 48kHz, PGA gain = 0dB, 24-bit audio data unless otherwise stated.

PARAMETER		TEST CONDITIONS	MIN	TYP	MAX	UNIT	
ADC Input Path Performance							
D1	SNR (A-weighted)	Line inputs to ADC via INMIXL and INMIXR, AVDD = 3.3V		85	94		dB
	THD (-1dBFS input)			-84	-75		dB
	THD+N (-1dBFS input)			-82	-73		dB
	Crosstalk (L/R)			-100			dB
	AVDD PSRR (217Hz)			45			dB
	DCVDD PSRR (217Hz)			80			dB
	SNR (A-weighted)	Line inputs to ADC via INMIXL and INMIXR, AVDD = 2.7V		93			dB
	THD (-1dBFS input)			-78			dB
	THD+N (-1dBFS input)			-76			dB
	Crosstalk (L/R)			-95			dB
D2	SNR (A-weighted)	Record path (DACs to ADCs via INMIXL and INMIXR), AVDD = 3.3V		93			dB
	THD (-1dBFS input)			-83			dB
	THD+N (-1dBFS input)			-81			dB
	Crosstalk (L/R)	-95			dB		
	SNR (A-weighted)	Record path (DACs to ADCs via INMIXL and INMIXR), AVDD = 2.7V		92			dB
	THD (-1dBFS input)			-78			dB
THD+N (-1dBFS input)	-76					dB	
D3	SNR (A-weighted)	Input PGAs to ADC via INMIXL or INMIXR, AVDD = 3.3V		85	94		dB
	THD (-1dBFS input)			-84	-75		dB
	THD+N (-1dBFS input)			-82	-73		dB
	Crosstalk (L/R)			-100			dB
	AVDD PSRR (217Hz)	45			dB		
	SNR (A-weighted)	Input PGAs to ADC via INMIXL or INMIXR, AVDD = 2.7V		92			dB
	THD (-1dBFS input)			-78			dB
	THD+N (-1dBFS input)			-76			dB
Crosstalk (L/R)	-95					dB	
D4	SNR (A-weighted)	Input PGAs to ADC via DIFFINL or DIFFINR, AVDD = 3.3V		85	94		dB
	THD (-1dBFS input)			-82	-75		dB
	THD+N (-1dBFS input)			-80	-73		dB
	Crosstalk (L/R)	-100			dB		
	SNR (A-weighted)	Input PGAs to ADC via DIFFINL or DIFFINR, AVDD = 2.7V		92			dB
	THD (-1dBFS input)			-73			dB
THD+N (-1dBFS input)	-71					dB	
D5	SNR (A-weighted)	RXP-RXN to one ADC via RXVOICE, AVDD = 3.3V		94			dB
	THD (-1dBFS input)			-81			dB
	THD+N (-1dBFS input)			-79			dB
	SNR (A-weighted)	RXP-RXN to one ADC via RXVOICE, AVDD = 2.7V		92			dB
	THD (-1dBFS input)			-78			dB
	THD+N (-1dBFS input)			-76			dB

Test Conditions

DCVDD = 1.8V, DBVDD = 3.3V, AVDD = HPVDD = 3.3V, SPKVDD = 5V, T_A = +25°C, 1kHz signal, f_s = 48kHz, PGA gain = 0dB, 24-bit audio data unless otherwise stated.

PARAMETER		TEST CONDITIONS	MIN	TYP	MAX	UNIT	
DAC Output Path (Line Outputs 10kΩ / 50pF Load, Headphone Outputs 16Ω Load, Speaker Output 8Ω BTL Load)							
E1	SNR (A-weighted)	DAC to single-ended line out, 0dBFS input, AVDD = 3.3V		99		dB	
	THD			-86		dB	
	THD+N			-84		dB	
	Crosstalk (L/R)			-100		dB	
	AVDD PSRR (217Hz)			45		dB	
	SNR (A-weighted)	DAC to single-ended line out, 0dBFS input, AVDD = 2.7V		97		dB	
	THD			-89		dB	
	THD+N			-87		dB	
E2	SNR (A-weighted)	DAC to differential line out, 0dBFS input, AVDD = 3.3V		99		dB	
	THD			-86		dB	
	THD+N			-84		dB	
	Crosstalk (L/R)			-100		dB	
	AVDD PSRR (217Hz)			60		dB	
	DC Offset at Load			5		mV	
	SNR (A-weighted)	DAC to differential line out, 0dBFS input, AVDD = 2.7V		97		dB	
	THD			-90		dB	
THD+N	-88			dB			
E3	Minimum Line Out Resistance	LOP, LON, ROP, RON	2			kΩ	
E4	Maximum Line Out Capacitance	LOP, LON, ROP, RON			10	nF	
E5	SNR (A-weighted)	DAC to LOUT or ROUT, R _L =32Ω, AVDD=HPVDD= 3.3V		32Ω AC-Coupled Headphone Outputs			
	THD (P _O =20mW)			99		dB	
	THD+N (P _O =20mW)			-81		dB	
	THD (P _O =5mW)			-79		dB	
	THD+N (P _O =5mW)			-77		dB	
	Crosstalk (L/R)			-75		dB	
	AVDD PSRR (217Hz)			-100		dB	
	HPVDD PSRR (217Hz)			45		dB	
	SNR (A-weighted)			85		dB	
E6	SNR (A-weighted)	DAC to LOUT or ROUT, R _L =16Ω, AVDD=HPVDD= 3.3V		16Ω AC-Coupled Headphone Outputs			
	THD (P _O =20mW)			90	99		dB
	THD+N (P _O =20mW)			-77	-72		dB
	THD (P _O =5mW)			-75	-70		dB
	THD+N (P _O =5mW)			-73			dB
	Crosstalk (L/R)			-71			dB
	AVDD PSRR (217Hz)			-100			dB
	HPVDD PSRR (217Hz)	45				dB	
	SNR (A-weighted)	85				dB	
	SNR (A-weighted)	DAC to LOUT, or ROUT, R _L =16Ω, AVDD=HPVDD= 2.7V		97			dB
	THD (P _O =20mW)			-74			dB
	THD+N (P _O =20mW)			-72			dB
	THD (P _O =5mW)			-72			dB
THD+N (P _O =5mW)	-70				dB		

Test Conditions

DCVDD = 1.8V, DBVDD = 3.3V, AVDD = HPVDD = 3.3V, SPKVDD = 5V, T_A = +25°C, 1kHz signal, f_s = 48kHz, PGA gain = 0dB, 24-bit audio data unless otherwise stated.

PARAMETER		TEST CONDITIONS	MIN	TYP	MAX	UNIT				
E7	SNR (A-weighted)	DAC to LOUT/OUT3 or ROUT/OUT4, R _L =16Ω, AVDD=HPVDD=3.3V					99		dB	
	THD (P _O =20mW)						-71		dB	
	THD+N (P _O =20mW)						-69		dB	
	THD (P _O =5mW)						-67		dB	
	THD+N (P _O =5mW)						-65		dB	
	Crosstalk (L/R)						-100		dB	
	AVDD PSRR (217Hz)						60		dB	
	HPVDD PSRR (217Hz)	85		dB						
	DC Offset at Load		5		mV					
	SNR (A-weighted)	DAC to LOUT/OUT3 or ROUT/OUT4, R _L =16Ω, AVDD=HPVDD=2.7V	98		dB					
	THD (P _O =20mW)		-70		dB					
	THD+N (P _O =20mW)		-68		dB					
	THD (P _O =5mW)		-66		dB					
	THD+N (P _O =5mW)		-64		dB					
E8			DAC to LOUT or ROUT Capless (OUT3 or 4 as pseudo GND), R _L =16Ω, AVDD=HPVDD=3.3V					99		dB
THD (P _O =20mW)	-73								dB	
THD+N (P _O =20mW)	-71							dB		
THD (P _O =5mW)	-69							dB		
THD+N (P _O =5mW)	-67							dB		
Crosstalk (L/R)	-45							dB		
AVDD PSRR (217Hz)	45							dB		
HPVDD PSRR (217Hz)	85		dB							
SNR (A-weighted)	DAC to LOUT, or ROUT Capless (OUT3 or 4 as pseudo GND), R _L =16Ω, AVDD=HPVDD=2.7V	97		dB						
THD (P _O =20mW)		-70		dB						
THD+N (P _O =20mW)		-68		dB						
THD (P _O =5mW)		-67		dB						
THD+N (P _O =5mW)		-65		dB						
E9	Minimum Headphone Resistance	LOUT, ROUT, OUT3, OUT4	15			Ω				
E10	SPKVDD Leakage Current	SPKVDD=5.0V,		1		uA				
E11	SNR (A-weighted)	DAC to Speaker Output (Direct) AVDD=3.3V, SPKVDD=5V, class D, P _O controlled using DAC volume, ACGAIN=DCGAIN IN=1.52					93		dB	
	THD (P _O =0.5W)						-87		dB	
	THD+N (P _O =0.5W)						-85		dB	
	THD (P _O =1.0W)						-76		dB	
	THD+N (P _O =1.0W)						-74		dB	
	SPKVDD PSRR(217Hz)						75		dB	
	SNR (A-weighted)						DAC to Speaker Output (Direct) AVDD=3.3V, SPKVDD=5V, class AB, P _O controlled using DAC volume	97		dB
	THD (P _O =0.5W)	-78	-70	dB						
	THD+N (P _O =0.5W)	-76	-68	dB						
	THD (P _O =1.0W)	-76	-66	dB						
	THD+N (P _O =1.0W)	-74	-64	dB						
	SPKVDD PSRR(217Hz)	75		dB						
	DC Offset at Load		5		mV					

Test Conditions

DCVDD = 1.8V, DBVDD = 3.3V, AVDD = HPVDD = 3.3V, SPKVDD = 5V, T_A = +25°C, 1kHz signal, f_s = 48kHz, PGA gain = 0dB, 24-bit audio data unless otherwise stated.

PARAMETER		TEST CONDITIONS	MIN	TYP	MAX	UNIT
Bypass Path Performance (Line Outputs 10kΩ / 50pF load, Headphone Outputs 16Ω load, Speaker Output 8Ω BTL load)						
F1	SNR (A-weighted)	Differential Input on RXP/RXN to Differential Output on OUT3/OUT4, AVDD=HPVDD=3.3V		110		dB
	THD (P _O =20mW)			-72		dB
	THD+N (P _O =20mW)			-70		dB
	THD (P _O =5mW)			-68		dB
	THD+N (P _O =5mW)			-66		dB
	AVDD PSRR (217Hz)			80		dB
	HPVDD PSRR (217Hz)			90		dB
	DC Offset at Load			5		mV
	SNR (A-weighted)	Differential Input on RXP/RXN to Differential Output on OUT3/OUT4, AVDD=HPVDD=2.7V		108		dB
	THD (P _O =20mW)			-70		dB
	THD+N (P _O =20mW)			-68		dB
	THD (P _O =5mW)			-67		dB
	THD+N (P _O =5mW)			-65		dB
	THD+N (P _O =5mW)			-65		dB
F2	SNR (A-weighted)	RXVOICE via LOMIX or ROMIX to Headphone Outputs, AVDD=HPVDD=3.3V		100		dB
	THD (P _O =20mW)			-77		dB
	THD+N (P _O =20mW)			-75		dB
	THD (P _O =5mW)			-73		dB
	THD+N (P _O =5mW)			-71		dB
	AVDD PSRR (217Hz)			45		dB
	HPVDD PSRR (217Hz)			85		dB
	SNR (A-weighted)	RXVOICE via LOMIX or ROMIX to Headphone Outputs, AVDD=HPVDD=2.7V		98		dB
	THD (P _O =20mW)			-74		dB
	THD+N (P _O =20mW)			-72		dB
	THD (P _O =5mW)			-72		dB
	THD+N (P _O =5mW)			-70		dB
	THD+N (P _O =5mW)			-70		dB
	THD+N (P _O =5mW)			-70		dB
F3	SNR (A-weighted)	Line Input to SPKMIX, AVDD=3.3V, SPKVDD=5V, ACGAIN=DCGAIN=1.52, Class D Mode		93		dB
	THD (P _O =0.5W)			-87		dB
	THD+N (P _O =0.5W)			-85		dB
	THD (P _O =1.0W)			-81		dB
	THD+N (P _O =1.0W)			-79		dB
	AVDD PSRR (217Hz)			45		dB
	SPKVDD PSRR(217Hz)			80		dB
	DC Offset at Load			5		mV
	SNR (A-weighted)	Line Input to SPKMIX, AVDD=3.3V, SPKVDD=5V, Class AB Mode		91	101	dB
	THD (P _O =0.5W)			-78	-70	dB
	THD+N (P _O =0.5W)			-76	-68	dB
	THD (P _O =1.0W)			-76	-66	dB
	THD+N (P _O =1.0W)			-74	-64	dB
	AVDD PSRR (217Hz)			45		dB
	SPKVDD PSRR(217Hz)			80		dB
	DC Offset at Load			5		mV

Test Conditions

DCVDD = 1.8V, DBVDD = 3.3V, AVDD = HPVDD = 3.3V, SPKVDD = 5V, T_A = +25°C, 1kHz signal, f_s = 48kHz, PGA gain = 0dB, 24-bit audio data unless otherwise stated.

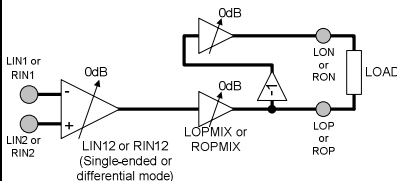
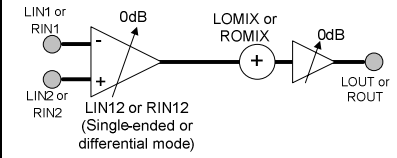
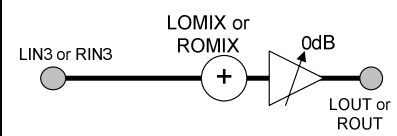
PARAMETER		TEST CONDITIONS	MIN	TYP	MAX	UNIT		
F4	SNR (A-weighted)	Input PGA to Differential Line Out, AVDD=3.3V		90	101		dB	
	THD (0dB output)			-99	-90		dB	
	THD+N (0dB output)			-97	-88		dB	
	AVDD PSRR (217Hz)			45			dB	
	DC Offset at Load			5			mV	
	SNR (A-weighted)			Input PGA to Differential Line Out, AVDD=2.7V	100			dB
	THD (0dB output)				-95			dB
F5	SNR (A-weighted)	Input PGA via LOMIX or ROMIX to LOUT or ROUT, R _L =16Ω, AVDD=HPVDD=3.3V		92	102		dB	
	THD (P _O =20mW)			-77	-72		dB	
	THD+N (P _O =20mW)			-75	-70		dB	
	THD (P _O =5mW)			-73			dB	
	THD+N (P _O =5mW)			-71			dB	
	AVDD PSRR (217Hz)			45			dB	
	HPVDD PSRR (217Hz)			85			dB	
	Crosstalk (L/R)	-95			dB			
	SNR (A-weighted)	Input PGA via LOMIX or ROMIX to LOUT or ROUT, R _L =16Ω, AVDD=HPVDD=2.7V	100			dB		
	THD (P _O =20mW)		-74			dB		
	THD+N (P _O =20mW)		-72			dB		
	THD (P _O =5mW)		-72			dB		
	THD+N (P _O =5mW)		-70			dB		
	Crosstalk (L/R)		-95			dB		
F6	SNR (A-weighted)	Line Input to Headphones via LOMIX and ROMIX, R _L =16Ω, AVDD=HPVDD=3.3V		104			dB	
	THD (P _O =20mW)			-77			dB	
	THD+N (P _O =20mW)			-75			dB	
	THD (P _O =5mW)			-73			dB	
	THD+N (P _O =5mW)			-71			dB	
	AVDD PSRR (217Hz)			70			dB	
	HPVDD PSRR (217Hz)			85			dB	
	Crosstalk (L/R)	-95			dB			
	SNR (A-weighted)	Line Input to Headphones via LOMIX and ROMIX, R _L =16Ω, AVDD=HPVDD=2.7V	102			dB		
	THD (P _O =20mW)		-74			dB		
	THD+N (P _O =20mW)		-72			dB		
	THD (P _O =5mW)		-72			dB		
	THD+N (P _O =5mW)		-70			dB		
	Crosstalk (L/R)		-95			dB		

Test Conditions

DCVDD = 1.8V, DBVDD = 3.3V, AVDD = HPVDD = 3.3V, SPKVDD = 5V, T_A = +25°C, 1kHz signal, fs = 48kHz, PGA gain = 0dB, 24-bit audio data unless otherwise stated.

PARAMETER	TEST CONDITIONS	MIN	TYP	MAX	UNIT	
Multi-Path Channel Separation						
G1	<p>Headset Voice Call: DAC/Headset to Tx Voice Separation</p> <p>1kHz 0dBFS DAC playback to LOOUT and ROOUT; Quiescent input on LIN12 or RIN12 (Gain=+12dB), differential output to LOP/LON or ROP/RON; Measure crosstalk at LOP/LON or ROP/RON output</p>				85	dB
G2	<p>Headset Voice Call: DAC/Speaker to Tx Voice Separation</p> <p>1kHz 0dBFS DAC playback to speaker, 1W output; Quiescent input on LIN12 or RIN12 (Gain=+12dB), differential output to LOP/LON or ROP/RON; Measure crosstalk at LOP/LON or ROP/RON output</p>				100	dB
G3	<p>PCM Voice Call: Rx Voice to Tx Voice Separation</p> <p>fs=8kHz for ADC and DAC, DAC_SB_FILT=1; -5dBFS differential mono output from DACs to OUT3/OUT4; Quiescent input on input PGA (Gain=+12dB) to ADC via INMIXL or INMIXR; Measure crosstalk at ADC output</p>				90	dB
G4	<p>Speakerphone PCM Voice Call: DAC/Speaker to ADC Separation</p> <p>fs=8kHz for ADC and DAC, DAC_SB_FILT=1; 0dBFS DAC output to speaker (1W output); ADC record from input PGA (Gain=+30dB); Measure crosstalk on ADC output</p>				85	dB
G5	<p>Ear Speaker Voice Call: Tx Voice and Rx Voice Separation</p> <p>1kHz Full scale differential input on RXP/RXN, output to OUT3/OUT4; Quiescent input on LIN12 or RIN12 (Gain=+12dB), differential output to LOP/LON or ROP/RON; Measure crosstalk at LOP/LON or ROP/RON output</p>				70	dB

Test Conditions

DCVDD = 1.8V, DBVDD = 3.3V, AVDD = HPVDD = 3.3V, SPKVDD = 5V, T_A = +25°C, 1kHz signal, fs = 48kHz, PGA gain = 0dB, 24-bit audio data unless otherwise stated.

	PARAMETER	TEST CONDITIONS	MIN	TYP	MAX	UNIT
G6	<p>Headset Voice Call: Tx Voice and Rx Voice Separation</p> <p>1kHz full scale differential input on RXP/RXN via RXVOICE to LOMIX and ROMIX, output to LOUT and ROUT; Quiescent input on LIN12 or RIN12 (Gain=+12dB), differential output to LOP/LON or ROP/RON; Measure crosstalk at LOP/LON or ROP/RON output</p>			75		dB
G7	<p>Stereo Line Record and Playback: DAC/Headset to ADC Separation</p> <p>-5dBFS input to DACs, playback to LOUT and ROUT1; ADC record from line input; Measure crosstalk on ADC output</p>			90		dB

Test Conditions

DCVDD = 1.8V, DBVDD = 3.3V, AVDD = HPVDD = 3.3V, SPKVDD = 5V, T_A = +25°C, 1kHz signal, f_s = 48kHz,
PGA gain = 0dB, 24-bit audio data unless otherwise stated.

PARAMETER	TEST CONDITIONS	MIN	TYP	MAX	UNIT	
Analogue Reference Levels						
H1	VMID Midrail Reference Voltage	-3%	AVDD/2	+3%	V	
Microphone Bias						
H2	Bias Voltage	3mA load current M1BSEL=0 / M2BSEL=0	-5%	0.9×AVDD	+5%	V
		3mA load current M1BSEL=1 / M2BSEL=1	-5%	0.65×AVDD	+5%	V
H3	Bias Current Source			3	mA	
H4	Output Noise Density	1kHz to 20kHz	100		nV/√Hz	
H5	AVDD PSRR (217Hz)	100mV pk-pk @217Hz on AVDD	45		dB	
Digital Input / Output						
H6	Input HIGH Level		0.7×DBVDD		V	
H7	Input LOW Level			0.3×DBVDD	V	
Note that digital input pins should not be left unconnected / floating. Internal pull-up/pull-down resistors may be enabled on GPIO1-6 if required.						
H8	Output HIGH Level	I _{OL} =1mA	0.9×DBVDD		V	
H9	Output LOW Level	I _{OH} =-1mA		0.1×DBVDD	V	
H10	Input capacitance		10		pF	
H11	Input leakage		-0.9	0.9	µA	
PLL						
H12	Input Frequency	PRESCALE = 0b	10		17	MHz
		PRESCALE = 1b	20		34	MHz
H13	Lock time		200		µs	
GPIO						
H14	Clock output duty cycle (Integer OPCLKDIV)	SYCLK=MCLK; OPCLKDIV=0000	35		65	%
		SYCLK=MCLK; OPCLKDIV=1000	45		55	%
		SYCLK=PLL output; OPCLKDIV=0000	45		55	%
		SYCLK=PLL output; OPCLKDIV=1000	45		55	%
H15	Clock output duty cycle (Non-integer OPCLKDIV)	SYCLK=MCLK; OPCLKDIV=0100	33		66	%
		SYCLK=PLL output; OPCLKDIV=0100	33		66	%
H16	Interrupt response time for accessory / button detect	Input de-bounced	2 ²¹ / f _{SYCLK}		2 ²² / f _{SYCLK}	s
		Input de-bounced TOCLKSEL=1	2 ¹⁹ / f _{SYCLK}		2 ²⁰ / f _{SYCLK}	s
		Input not de-bounced		0		s

TERMINOLOGY

1. Signal-to-Noise Ratio (dB) – SNR is a measure of the difference in level between the maximum theoretical full scale output signal and the output with no input signal applied.
2. Total Harmonic Distortion (dB) – THD is the level of the rms value of the sum of harmonic distortion products relative to the amplitude of the measured output signal.
3. Total Harmonic Distortion plus Noise (dB) – THD+N is the level of the rms value of the sum of harmonic distortion products plus noise in the specified bandwidth relative to the amplitude of the measured output signal.
4. Crosstalk (L/R) (dB) – left-to-right and right-to-left channel crosstalk is the measured signal level in the idle channel at the test signal frequency relative to the signal level at the output of the active channel. The active channel is configured and supplied with an appropriate input signal to drive a full scale output, with signal measured at the output of the associated idle channel. For example, measured signal level on the output of the idle right channel (RIN2 to ADCR) with a full scale signal level at the output of the active left channel (LIN1 to ADCL).
5. Multi-Path Channel Separation (dB) – is the measured signal level in the idle path at the test signal frequency relative to the signal level at the output of the active path. The active path is configured and supplied with an appropriate input signal to drive a full scale output, with signal measured at the output of the specified idle path.
6. All performance measurements carried out with 20kHz low pass filter, and where noted an A-weighted filter. Failure to use such a filter will result in higher THD and lower SNR readings than are found in the Electrical Characteristics. The low pass filter removes out of band noise; although it is not audible it may affect dynamic specification values.
7. Mute Attenuation – This is a measure of the difference in level between the full scale output signal and the output with mute applied.

TYPICAL POWER CONSUMPTION

Control Register		Other settings	AVDD	HPVDD	SPKVDD	DBVDD	DCVDD	IAVDD	IHPVDD	ISPKVDD	IDBVDD	IDCVDD	Total Power
Mode	T _{AMB}		(V)	(V)	(V)	(V)	(V)	(mA)	(mA)	(mA)	(mA)	(mA)	(mW)
OFF (default state at power-up)	01	No Clocks	2.7	2.7	3.3	1.8	1.8	0.028	0.000	0.000	0.000	0.000	0.074
	11		3.0	3.0	3.6	2.5	2.5	0.029	0.000	0.000	0.000	0.000	0.086
	11		3.3	3.3	4.2	3.3	3.3	0.030	0.000	0.000	0.000	0.000	0.099
	11		3.6	3.6	5.0	3.6	3.6	0.031	0.000	0.000	0.000	0.000	0.114
OFF (thermal sensor disabled)	01	No Clocks	2.7	2.7	3.3	1.8	1.8	0.008	0.000	0.000	0.000	0.000	0.019
	11		3.0	3.0	3.6	2.5	2.5	0.008	0.000	0.000	0.000	0.000	0.024
	11		3.3	3.3	4.2	3.3	3.3	0.009	0.000	0.000	0.000	0.000	0.028
	11		3.6	3.6	5.0	3.6	3.6	0.009	0.000	0.000	0.000	0.000	0.035
SLEEP (VMID enabled, thermal sensor enabled)	01	With Clocks	2.7	2.7	3.3	1.8	1.8	0.087	0.000	0.000	0.004	0.459	1.067
	11		3.0	3.0	3.6	2.5	2.5	0.096	0.000	0.000	0.008	0.694	2.043
	11		3.3	3.3	4.2	3.3	3.3	0.106	0.000	0.000	0.014	1.025	3.779
	11		3.6	3.6	5.0	3.6	3.6	0.117	0.000	0.000	0.017	1.162	4.667
Stereo Line Record (LRIN2 to INMIXL/R bypassing PGA)	01	fs=44.1kHz	2.7	2.7	3.3	1.8	1.8	5.272	0.000	0.000	0.023	2.285	18.388
	11		3.0	3.0	3.6	2.5	2.5	5.603	0.000	0.000	0.039	3.317	25.198
	11		3.3	3.3	4.2	3.3	3.3	5.927	0.000	0.000	0.060	4.728	35.357
	11		3.6	3.6	5.0	3.6	3.6	6.261	0.000	0.000	0.083	5.295	41.830
Stereo Line Record (LRIN2 to INMIXL/R bypassing PGA)	01	fs=8kHz	2.7	2.7	3.3	1.8	1.8	6.125	0.000	0.000	0.017	0.758	15.232
	11		3.0	3.0	3.6	2.5	2.5	5.434	0.000	0.000	0.027	1.123	19.176
	11		3.3	3.3	4.2	3.3	3.3	5.738	0.000	0.000	0.061	1.634	24.527
	11		3.6	3.6	5.0	3.6	3.6	6.053	0.000	0.000	0.082	1.841	28.842
Playback to AC Coupled Headphones (DAC to L/ROUT) 16ohm load	01	fs=44.1kHz	2.7	2.7	3.3	1.8	1.8	2.950	0.705	0.000	0.003	2.147	13.739
	11		3.0	3.0	3.6	2.5	2.5	3.315	0.558	0.000	0.007	3.180	19.586
	11		3.3	3.3	4.2	3.3	3.3	3.684	0.640	0.000	0.013	4.544	29.307
	11		3.6	3.6	5.0	3.6	3.6	4.055	0.726	0.000	0.016	5.092	35.600
Playback to AC Coupled Headphones (DAC to L/ROUT) -20dBV Pink Noise into 16ohm load	01	fs=44.1kHz	2.7	2.7	3.3	1.8	1.8	2.951	1.430	0.000	0.004	2.288	15.971
	11		3.0	3.0	3.6	2.5	2.5	3.315	1.367	0.000	0.007	3.380	22.513
	11		3.3	3.3	4.2	3.3	3.3	3.683	1.544	0.000	0.013	4.817	33.189
	11		3.6	3.6	5.0	3.6	3.6	4.055	1.742	0.000	0.016	5.404	40.381
Playback to AC Coupled Headphones (DAC to L/ROUT) -30dBV Pink Noise into 16ohm load	01	fs=44.1kHz	2.7	2.7	3.3	1.8	1.8	2.950	0.628	0.000	0.004	2.263	14.279
	11		3.0	3.0	3.6	2.5	2.5	3.315	0.743	0.000	0.007	3.362	20.596
	11		3.3	3.3	4.2	3.3	3.3	3.684	0.835	0.000	0.013	4.762	30.671
	11		3.6	3.6	5.0	3.6	3.6	4.056	0.937	0.000	0.016	5.344	37.270
Playback to AC Coupled Headphones (DAC to L/ROUT) 0.1mW/channel into 16ohm load	01	fs=44.1kHz	2.7	2.7	3.3	1.8	1.8	2.950	2.563	0.000	0.004	2.251	18.943
	11		3.0	3.0	3.6	2.5	2.5	3.315	2.476	0.000	0.007	3.323	25.698
	11		3.3	3.3	4.2	3.3	3.3	3.683	2.508	0.000	0.014	4.736	36.103
	11		3.6	3.6	5.0	3.6	3.6	4.055	2.556	0.000	0.016	5.304	42.951
Playback to AC Coupled Headphones (DAC to L/ROUT) 5mW/channel into 16ohm load	01	fs=44.1kHz	2.7	2.7	3.3	1.8	1.8	2.952	15.767	0.000	0.004	2.256	54.808
	11		3.0	3.0	3.6	2.5	2.5	3.316	15.789	0.000	0.007	3.343	65.990
	11		3.3	3.3	4.2	3.3	3.3	3.683	15.675	0.000	0.013	4.762	79.640
	11		3.6	3.6	5.0	3.6	3.6	4.055	15.836	0.000	0.016	5.329	90.850
Playback to AC Coupled Headphones (DAC to L/ROUT) 32ohm load	01	fs=44.1kHz	2.7	2.7	3.3	1.8	1.8	2.951	0.699	0.000	0.004	2.147	13.725
	11		3.0	3.0	3.6	2.5	2.5	3.317	0.550	0.000	0.007	3.179	19.565
	11		3.3	3.3	4.2	3.3	3.3	3.684	0.629	0.000	0.013	4.543	29.268
	11		3.6	3.6	5.0	3.6	3.6	4.055	0.711	0.000	0.016	5.089	35.536
Playback to AC Coupled Headphones (DAC to L/ROUT) -20dBV Pink Noise into 32ohm load	01	fs=44.1kHz	2.7	2.7	3.3	1.8	1.8	2.951	1.019	0.000	0.004	2.302	14.868
	11		3.0	3.0	3.6	2.5	2.5	3.315	0.915	0.000	0.007	3.359	21.105
	11		3.3	3.3	4.2	3.3	3.3	3.684	1.045	0.000	0.014	4.806	31.509
	11		3.6	3.6	5.0	3.6	3.6	4.056	1.180	0.000	0.016	5.367	38.228
Playback to AC Coupled Headphones (DAC to L/ROUT) -30dBV Pink Noise into 32ohm load	01	fs=44.1kHz	2.7	2.7	3.3	1.8	1.8	2.950	0.748	0.000	0.004	2.265	14.067
	11		3.0	3.0	3.6	2.5	2.5	3.315	0.624	0.000	0.007	3.337	20.177
	11		3.3	3.3	4.2	3.3	3.3	3.683	0.704	0.000	0.013	4.786	30.314
	11		3.6	3.6	5.0	3.6	3.6	4.055	0.789	0.000	0.016	5.359	36.789
Playback to AC Coupled Headphones (DAC to L/ROUT) 0.1mW/channel into 32ohm load	01	fs=44.1kHz	2.7	2.7	3.3	1.8	1.8	2.950	1.950	0.000	0.004	2.253	17.291
	11		3.0	3.0	3.6	2.5	2.5	3.315	1.868	0.000	0.007	3.327	23.883
	11		3.3	3.3	4.2	3.3	3.3	3.683	1.905	0.000	0.014	4.741	34.129
	11		3.6	3.6	5.0	3.6	3.6	4.055	1.950	0.000	0.016	5.312	40.799
Playback to AC Coupled Headphones (DAC to L/ROUT) 5mW/channel into 32ohm load	01	fs=44.1kHz	2.7	2.7	3.3	1.8	1.8	2.955	11.421	0.000	0.004	2.267	42.901
	11		3.0	3.0	3.6	2.5	2.5	3.319	11.362	0.000	0.007	3.351	52.438
	11		3.3	3.3	4.2	3.3	3.3	3.686	11.349	0.000	0.014	4.777	65.423
	11		3.6	3.6	5.0	3.6	3.6	4.057	11.406	0.000	0.016	5.342	74.956
Playback to Line-Out (DAC to ROP/RON)	01	fs=44.1kHz	2.7	2.7	3.3	1.8	1.8	3.934	0.000	0.000	0.004	2.144	14.487
	11		3.0	3.0	3.6	2.5	2.5	4.184	0.000	0.000	0.007	3.179	20.517
	11		3.3	3.3	4.2	3.3	3.3	4.672	0.000	0.000	0.013	4.541	30.446
	11		3.6	3.6	5.0	3.6	3.6	5.166	0.000	0.000	0.016	5.089	36.976
Playback to Speaker Class D (DAC to SPK) 8ohm load	01	fs=44.1kHz	2.7	2.7	3.3	1.8	1.8	3.621	0.000	3.070	0.004	2.138	23.763
	11		3.0	3.0	3.6	2.5	2.5	4.080	0.000	3.652	0.007	3.167	33.322
	11		3.3	3.3	4.2	3.3	3.3	4.548	0.000	5.154	0.013	4.530	51.648
	11		3.6	3.6	5.0	3.6	3.6	5.021	0.000	7.223	0.016	5.073	72.511
Playback to Speaker Class AB (DAC to SPK) 8ohm load	01	fs=44.1kHz	2.7	2.7	3.3	1.8	1.8	3.087	0.000	2.823	0.004	2.125	21.482
	11		3.0	3.0	3.6	2.5	2.5	3.470	0.000	3.307	0.007	3.146	30.198
	11		3.3	3.3	4.2	3.3	3.3	3.856	0.000	4.061	0.013	4.496	44.662
	11		3.6	3.6	5.0	3.6	3.6	4.246	0.000	5.057	0.016	5.042	58.780
FM Radio to AC Coupled Headphones (LRIN3 to L/ROUT bypass via LROMIX) 16ohm load	01		2.7	2.7	3.3	1.8	1.8	0.442	0.697	0.000	0.000	0.000	3.074
	11		3.0	3.0	3.6	2.5	2.5	0.499	0.544	0.000	0.000	0.000	3.128
	11		3.3	3.3	4.2	3.3	3.3	0.556	0.621	0.000	0.000	0.000	3.884
	11		3.6	3.6	5.0	3.6	3.6	0.613	0.702	0.000	0.000	0.000	4.735
Analogue Voice Call to Handset Ear Speaker (MIC on LIN12 to LOP/LON) (RXP/RXN to OUT3/4 via RXVIOCE & AINLMUX)	01		2.7	2.7	3.3	1.8	1.8	2.307	0.796	0.000	0.000	0.000	8.377
	11		3.0	3.0	3.6	2.5	2.5	2.374	0.615	0.000	0.000	0.000	8.966
	11		3.3	3.3	4.2	3.3	3.3	2.660	0.703	0.000	0.000	0.000	11.097
	11		3.6	3.6	5.0	3.6	3.6	2.953	0.794	0.000	0.000	0.000	13.490
PCM Voice Call (MIC on LIN12 to LDAC) (-12dB sidetone to LDAC) (LDAC to OUT3, OUT4=MUTE)	01		2.7	2.7	3.3	1.8	1.8	5.043	0.382	0.000	0.011	2.290	18.789
	11		3.0	3.0	3.6	2.5	2.5	5.512	0.299	0.000	0.017	3.384	25.935
	11		3.3	3.3	4.2	3.3	3.3	5.981	0.343	0.000	0.027	4.820	36.862
	11		3.6	3.6	5.0	3.6	3.6	6.457	0.389	0.000	0.032	5.386	44.150

Notes:

- Power in the load is included.
- All figures are quoted at T_A = +25°C
- All figures are quoted as quiescent current unless otherwise stated.

SPEAKER DRIVER PERFORMANCE

Typical speaker driver THD+N performance is shown below for both Class D and Class AB modes. Curves are shown for four typical SPKVDD supply voltage and gain combinations.

Load $R_L = 8\Omega + 10\mu H$, Frequency = 1kHz, +1dB gain in active path.

SPEAKER CLASS D INTO $8\Omega + 10\mu H$

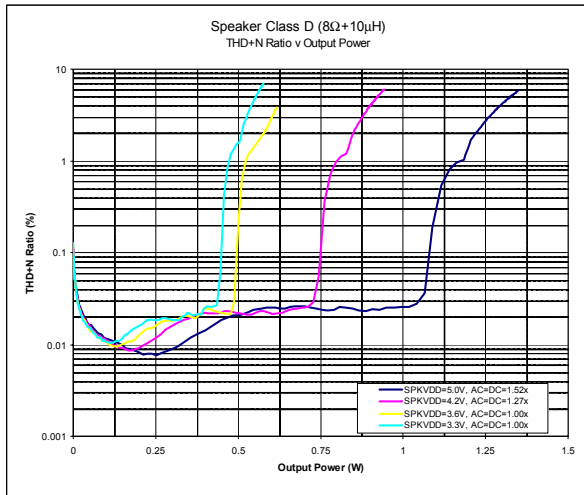

SPEAKER CLASS AB INTO $8\Omega + 10\mu H$

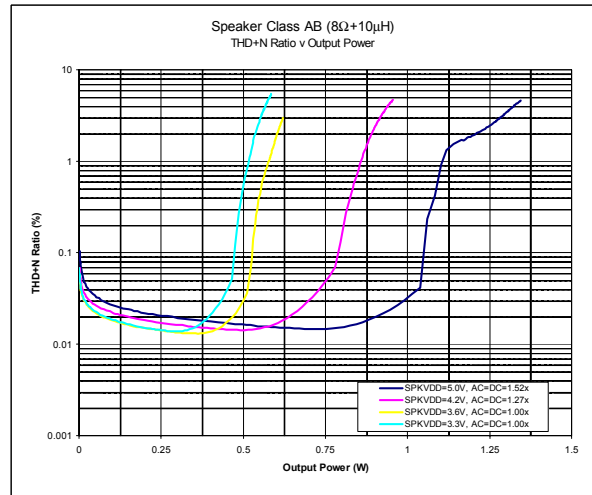

HEADPHONE DRIVER PERFORMANCE

Typical THD+N performance of the Headphone Drivers is shown below (AC coupled to LOUT/ROUT). Curves are shown for four HPVDD/AVDD supply voltages.

Load $R_L = 16\Omega$ and 32Ω , Frequency = 1kHz, +1dB gain in active path.

AC COUPLED HEADPHONE INTO 16Ω

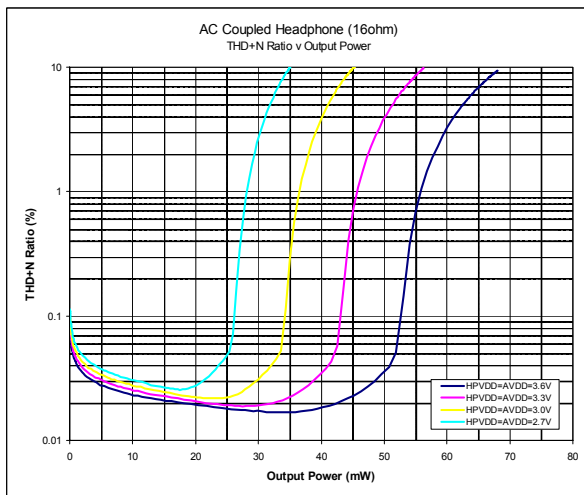

AC COUPLED HEADPHONE INTO 32Ω

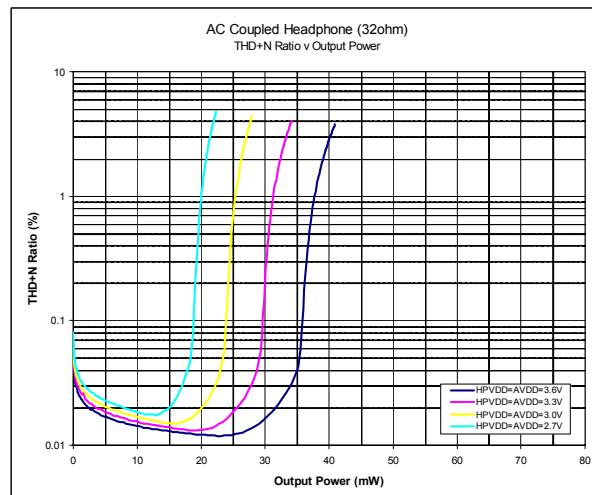

PSRR PERFORMANCE

SPKVDD – LIN2 TO SPEAKER

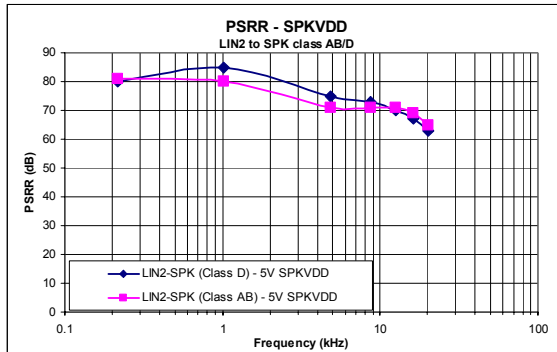

AVDD – LIN2 TO SPEAKER

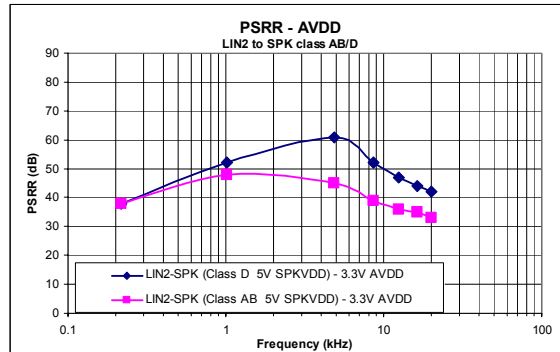

SPKVDD – DAC TO SPEAKER

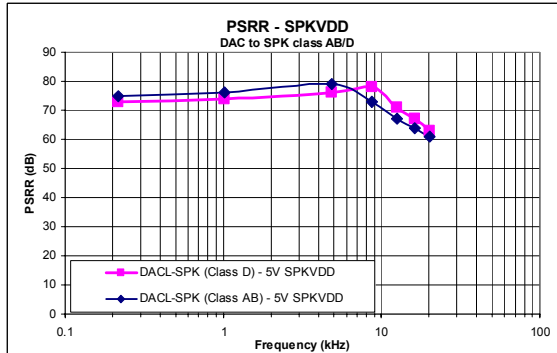

AVDD – DAC TO SPEAKER

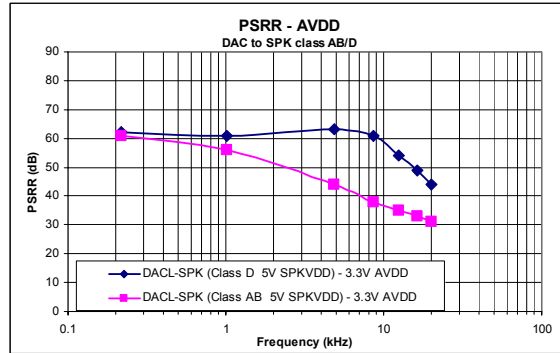

HPVDD – DAC TO HEADPHONE

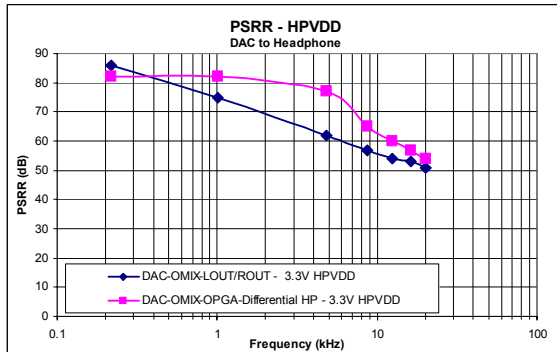

AVDD – DAC TO HEADPHONE

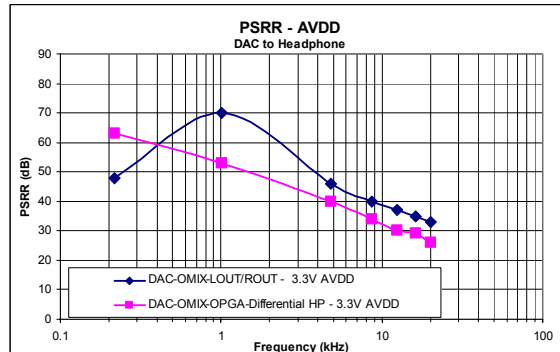

DCVDD – DAC TO HEADPHONE

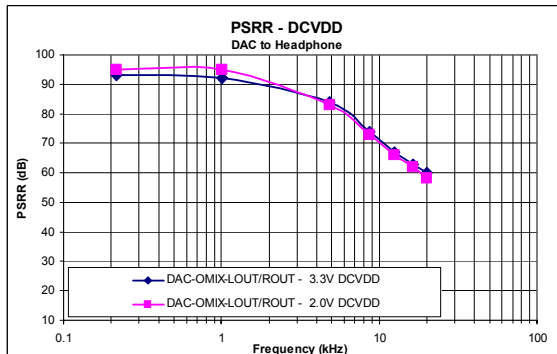

AVDD – MICBIAS

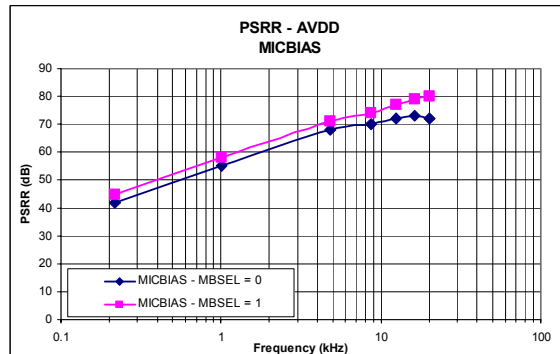

DCVDD – LINE-IN TO ADC

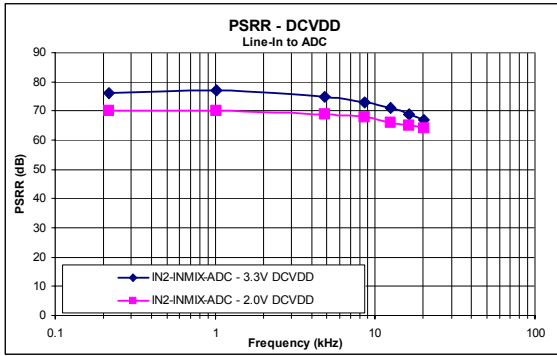

AVDD – LINE-IN TO ADC

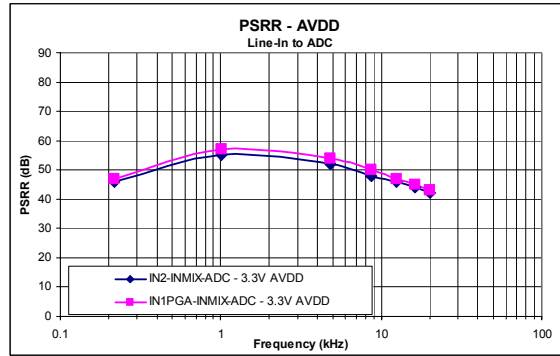

HPVDD – IN1 BYPASS

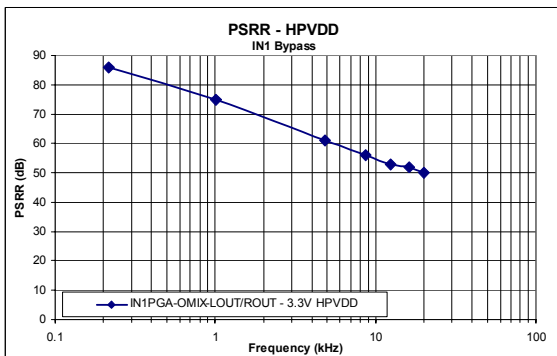

AVDD – IN1 BYPASS

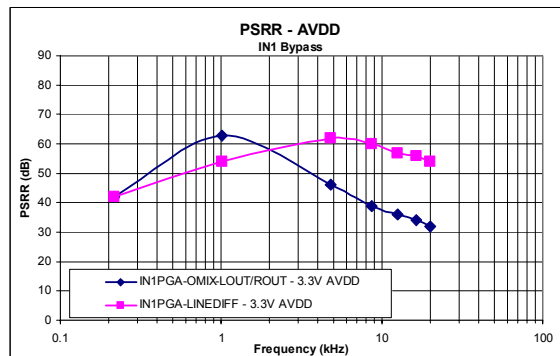

HPVDD – IN3 BYPASS

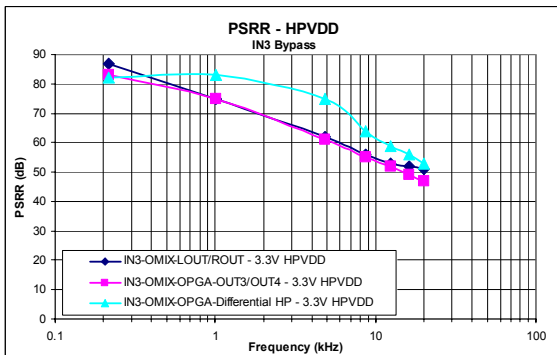

AVDD – IN3 BYPASS

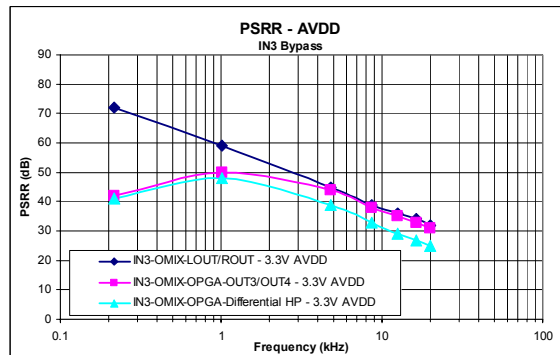

HPVDD – IN4 BYPASS

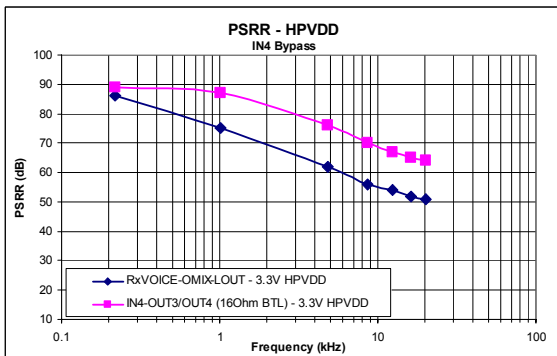

AVDD – IN4 BYPASS

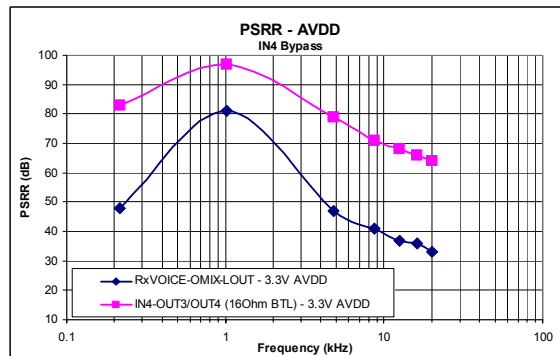

Note: All figures based on 100mVp-p injected on the supply at the relevant test frequency.

AUDIO SIGNAL PATHS

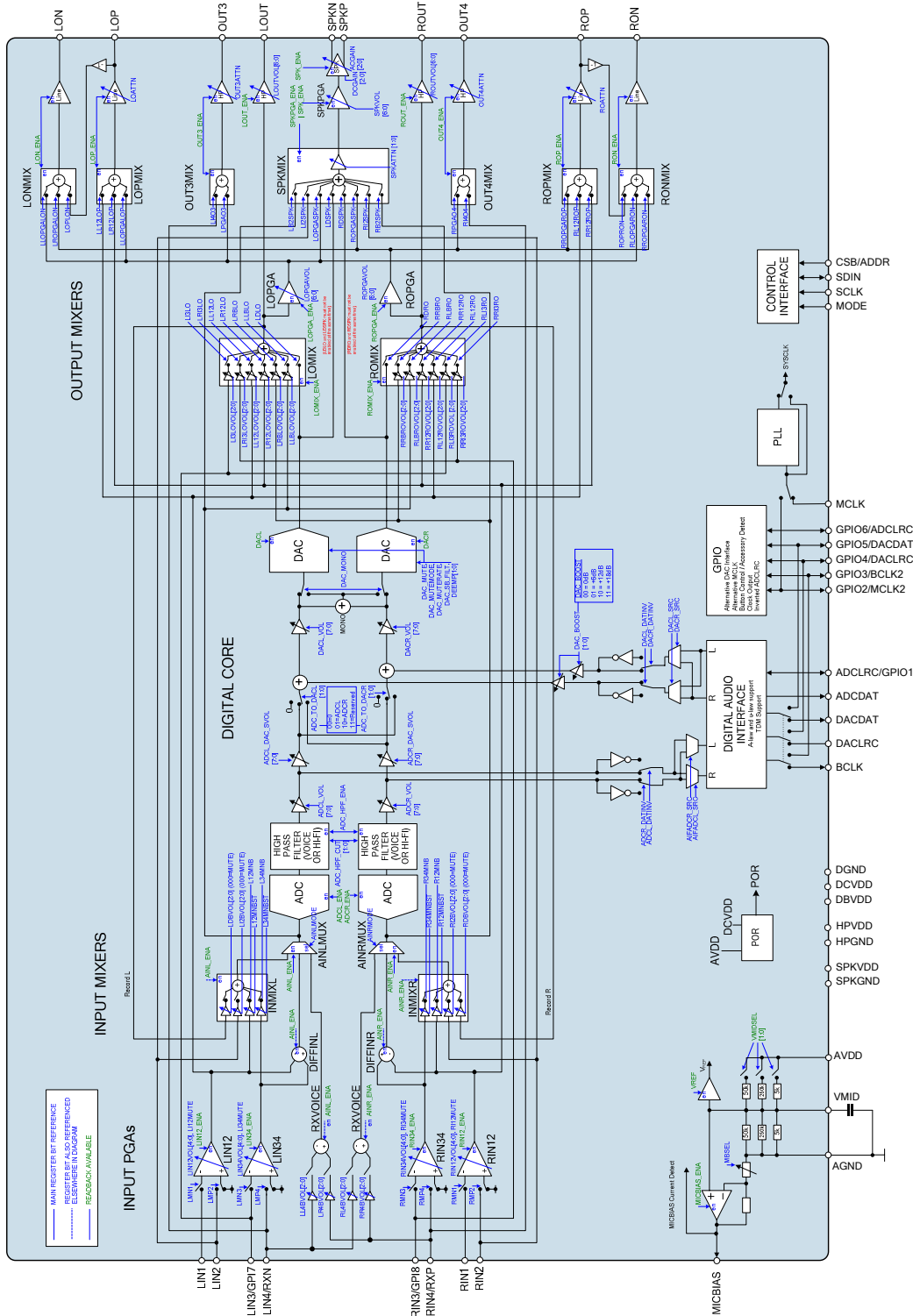

SIGNAL TIMING REQUIREMENTS

SYSTEM CLOCK TIMING

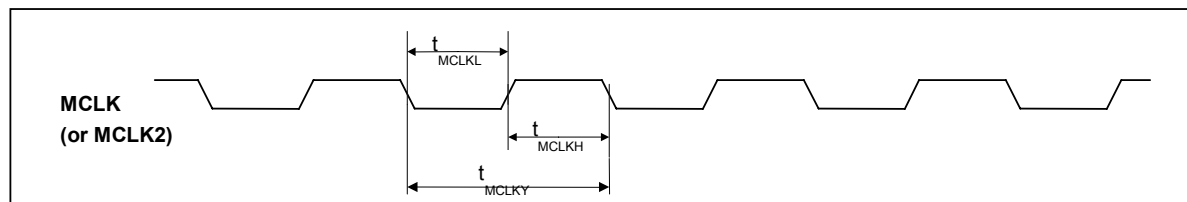

Figure 4 System Clock Timing Requirements

Test Conditions

DCVDD=1.8V, DBVDD=AVDD=3.3V, SPKVDD=5V, DGND=AGND=SPKGND=0V, $T_A = +25^\circ\text{C}$

PARAMETER	SYMBOL	CONDITIONS	MIN	TYP	MAX	UNIT
System Clock Timing Information						
MCLK or MCLK2 cycle time	T_{MCLKY}		33.33			ns
MCLK or MCLK2 duty cycle		$= T_{MCLKH}/T_{MCLKL}$	60:40		40:60	

AUDIO INTERFACE TIMING – MASTER MODE

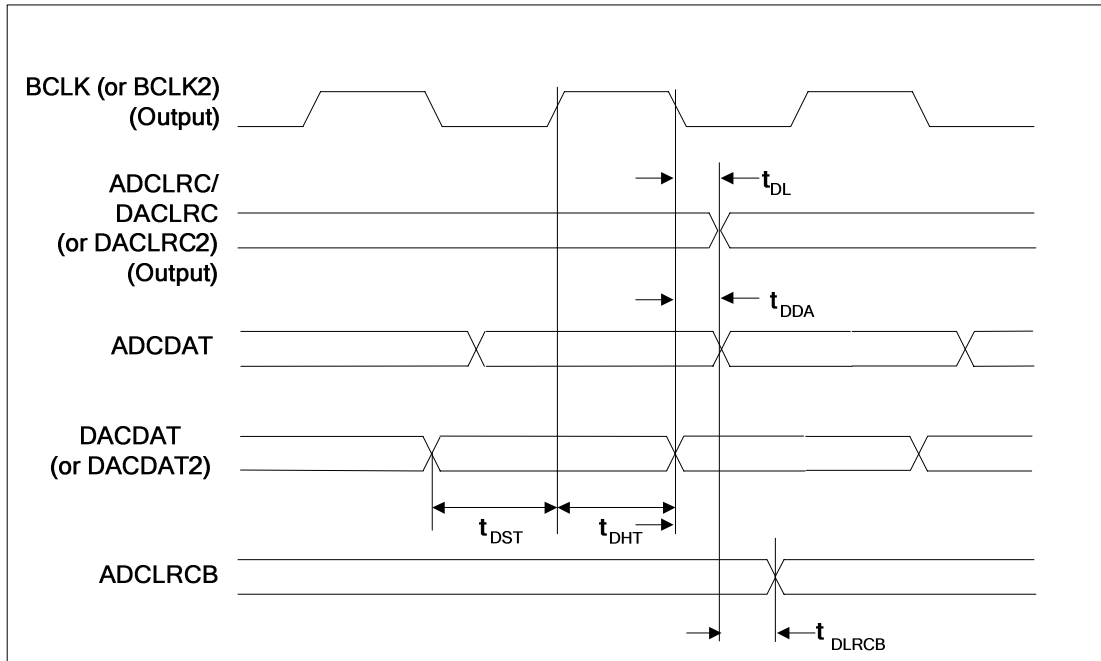

Figure 5 Digital Audio Data Timing - Master Mode (see Control Interface)

Test Conditions

DCVDD=1.8V, DBVDD=AVDD=3.3V, SPKVDD=5V, DGND=AGND=SPKGND=0V, T_A=+25°C, Master Mode, fs=48kHz, MCLK=256fs, 24-bit data, unless otherwise stated.

PARAMETER	SYMBOL	MIN	TYP	MAX	UNIT
Audio Data Timing Information					
ADCLRC/ DACLRC (or DACLRC2) propagation delay from BCLK (or BCLK2) falling edge	t _{DL}			20	ns
ADCDAT propagation delay from BCLK falling edge	t _{DDA}			20	ns
DACDAT (or DACDAT2) setup time to BCLK rising edge	t _{DST}	20			ns
DACDAT (or DACDAT2) hold time from BCLK rising edge	t _{DHT}	10			ns
ADCLRC to ADCLRCB delay	t _{DLRCB}			10	ns

AUDIO INTERFACE TIMING – SLAVE MODE

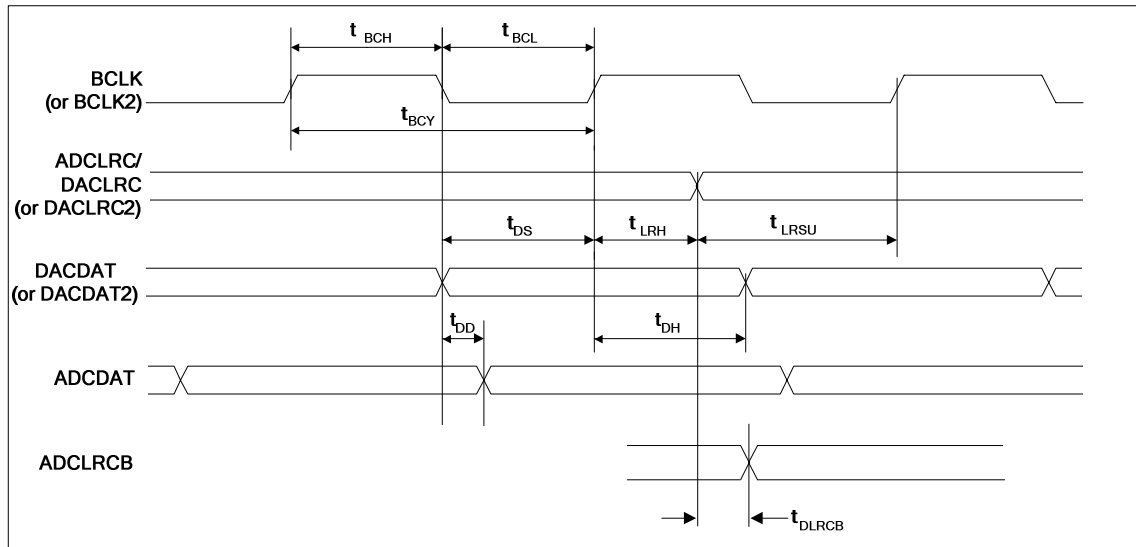

Figure 6 Digital Audio Data Timing – Slave Mode

Test Conditions

DCVDD=1.8V, DBVDD=AVDD=3.3, SPKVDD=5V, DGND=AGND=SPKGND=0V, T_A=+25°C, Slave Mode, fs=48kHz, MCLK=256fs, 24-bit data, unless otherwise stated.

PARAMETER	SYMBOL	MIN	TYP	MAX	UNIT
Audio Data Timing Information					
BCLK (or BCLK2) cycle time	t _{BCY}	50			ns
BCLK (or BCLK2) pulse width high	t _{BCH}	20			ns
BCLK (or BCLK2) pulse width low	t _{BCL}	20			ns
ADCLRC/ DACLRC (or DACLRC2) set-up time to BCLK (or BCLK2) rising edge	t _{LRSU}	20			ns
ADCLRC/ DACLRC (or DACLRC2) hold time from BCLK (or BCLK2) rising edge	t _{LRH}	10			ns
DACDAT (or DACDAT2) hold time from BCLK (or BCLK2) rising edge	t _{DH}	10			ns
ADCDAT propagation delay from BCLK falling edge	t _{DD}			20	ns
DACDAT (or DACDAT2) set-up time to BCLK (or BCLK2) rising edge	t _{DS}	20			ns
ADCLRC to ADCLRCB delay	t _{DLRCB}			20	ns

Note:

BCLK (or BCLK2) period should always be greater than or equal to MCLK (or MCLK2) period.

AUDIO INTERFACE TIMING – TDM MODE

In TDM mode, it is important that two ADC devices do not attempt to drive the ADCDAT pin simultaneously. The timing of the WM8991 ADCDAT tri-stating at the start and end of the data transmission is described in Figure 7 and the table below.

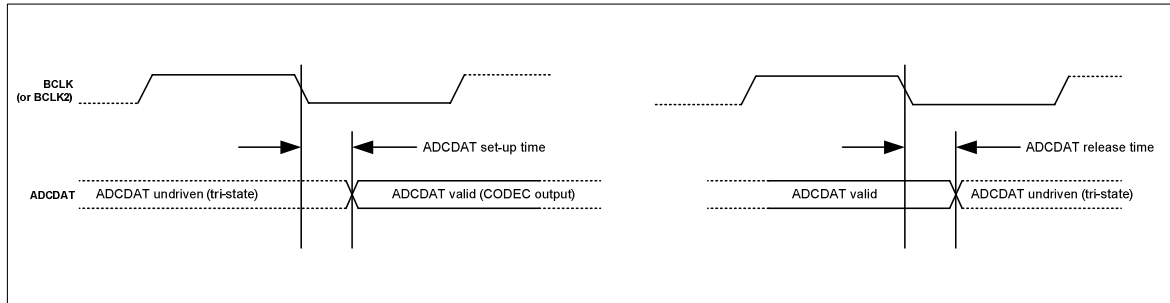

Figure 7 Digital Audio Data Timing - TDM Mode

Test Conditions

DBVDD=AVDD=3.3V, SPKVDD=5V, DGND=AGND=SPKGND=0V, T_A=+25°C, Master Mode, fs=48kHz, MCLK=256fs, 24-bit data, unless otherwise stated.

PARAMETER	CONDITIONS	MIN	TYP	MAX	UNIT
Audio Data Timing Information					
ADCDAT setup time from BCLK falling edge	DCVDD = DBVDD = 3.6V		5		ns
	DCVDD = DBVDD = 1.71V		15		ns
ADCDAT release time from BCLK falling edge	DCVDD = DBVDD = 3.6V		5		ns
	DCVDD = DBVDD = 1.71V		15		ns

CONTROL INTERFACE TIMING – 2-WIRE MODE

2-wire mode is selected by connecting the MODE pin low.

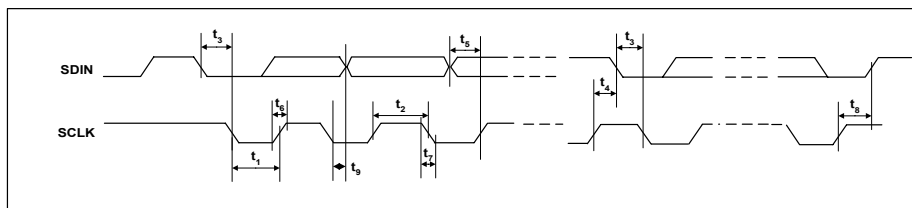

Figure 8 Control Interface Timing – 2-Wire Serial Control Mode

Test Conditions

DCVDD=1.8V, DBVDD=AVDD=HPVDD=3.3, SPKVDD=5V, DGND=AGND=HPGND=SPKGND=0V, $T_A=+25^{\circ}\text{C}$, Slave Mode, $f_s=48\text{kHz}$, MCLK = 256fs, 24-bit data, unless otherwise stated.

PARAMETER	SYMBOL	MIN	TYP	MAX	UNIT
Program Register Input Information					
SCLK Frequency				526	kHz
SCLK Low Pulse-Width	t_1	1.3			us
SCLK High Pulse-Width	t_2	600			ns
Hold Time (Start Condition)	t_3	600			ns
Setup Time (Start Condition)	t_4	600			ns
Data Setup Time	t_5	100			ns
SDIN, SCLK Rise Time	t_6			300	ns
SDIN, SCLK Fall Time	t_7			300	ns
Setup Time (Stop Condition)	t_8	600			ns
Data Hold Time	t_9			900	ns
Pulse width of spikes that will be suppressed	t_{ps}	0		5	ns

CONTROL INTERFACE TIMING – 3-WIRE MODE

3-wire mode is selected by connecting the MODE pin high.

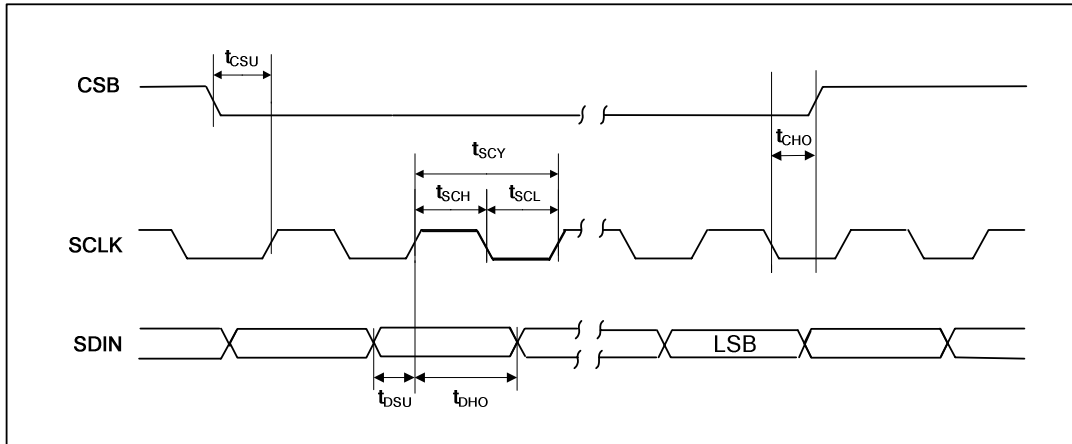

Figure 9 Control Interface Timing – 3-Wire Serial Control Mode (Write Cycle)

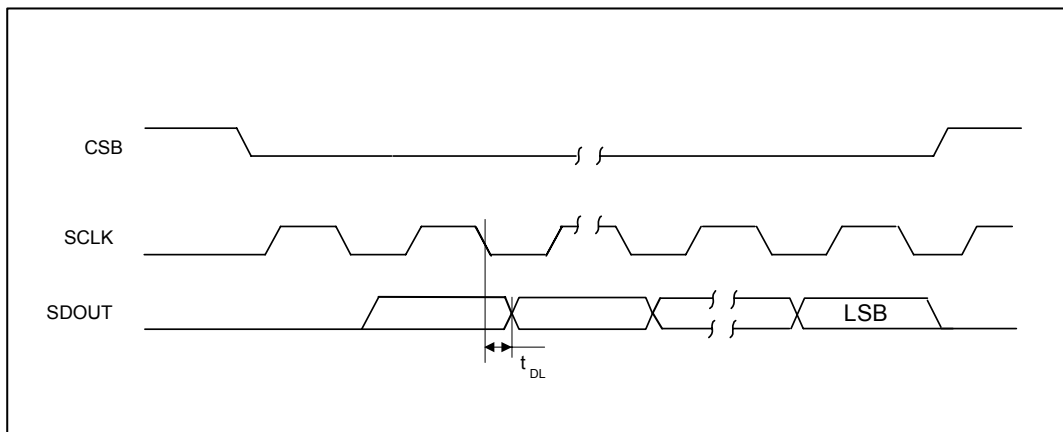

Figure 10 Control Interface Timing - 3-Wire Serial Control Mode (Read Cycle)

Test Conditions

DCVDD=1.8V, DBVDD=AVDD=HPVDD=3.3V, SPKVDD=5V, DGND=AGND=HPGND=SPKGND=0V, T_A=+25°C, Slave Mode, f_s=48kHz, MCLK=256fs, 24-bit data, unless otherwise stated.

PARAMETER	SYMBOL	MIN	TYP	MAX	UNIT
Program Register Input Information					
CSB falling edge to SCLK rising edge	t _{CSU}	40			ns
SCLK falling edge to CSB rising edge	t _{CHO}	40			ns
SCLK pulse cycle time	t _{SCY}	200			ns
SCLK pulse width low	t _{SCL}	80			ns
SCLK pulse width high	t _{SCH}	80			ns
SDIN to SCLK set-up time	t _{DSU}	40			ns
SDIN to SCLK hold time	t _{DHO}	10			ns
Pulse width of spikes that will be suppressed	t _{ps}	0		5	ns
SCLK falling edge to SDOUT transition	t _{DL}			40	ns

CONTROL INTERFACE TIMING – 4-WIRE MODE

4-wire mode supports readback via SDOOUT which is available as a GPIO pin function.

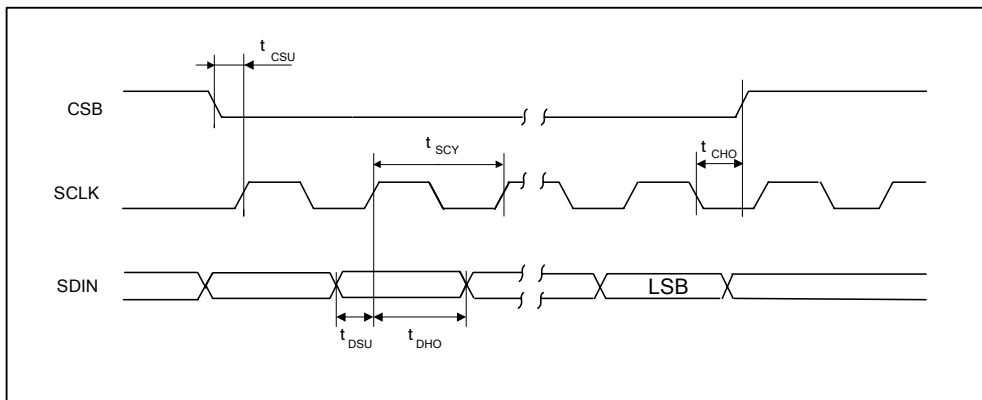

Figure 11 Control Interface Timing – 4-Wire Serial Control Mode (Write Cycle)

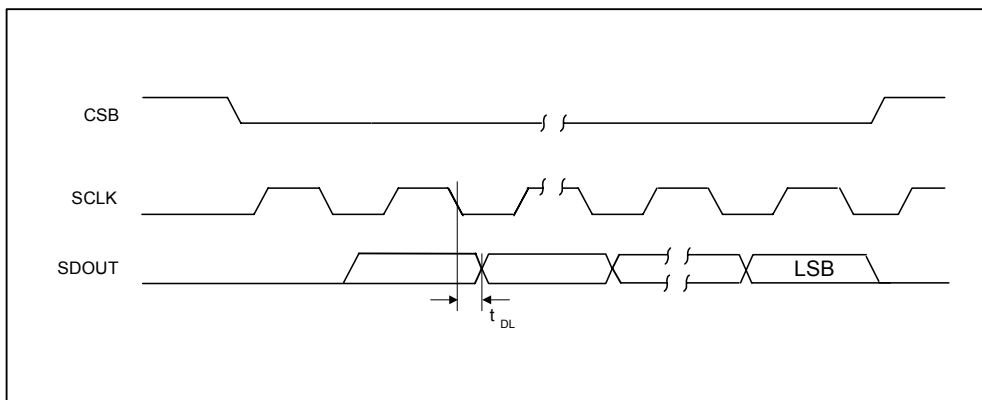

Figure 12 Control Interface Timing – 4-Wire Serial Control Mode (Read Cycle)

Test Conditions

DCVDD=1.8V, DBVDD=AVDD=HPVDD=3.3V, SPKVDD=5V, DGND=AGND=HPGND=SPKGND=0V, T_A =+25°C, Slave Mode, fs=48kHz, MCLK=256fs, 24-bit data, unless otherwise stated.

PARAMETER	SYMBOL	MIN	TYP	MAX	UNIT
Program Register Input Information					
SCLK rising edge to CSB falling edge	t _{CSU}	40			ns
SCLK falling edge to CSB rising edge	t _{CHO}	40			ns
SCLK pulse cycle time	t _{SCY}	200			ns
SCLK pulse width low	t _{SCL}	80			ns
SCLK pulse width high	t _{SCH}	80			ns
SDIN to SCLK set-up time	t _{DSU}	40			ns
SDIN to SCLK hold time	t _{DHO}	10			ns
SDOOUT propagation delay from SCLK rising edge	t _{DL}			10	ns
Pulse width of spikes that will be suppressed	t _{ps}	0		5	ns
SCLK falling edge to SDOOUT transition	t _{DL}			40	ns

INTERNAL POWER ON RESET CIRCUIT

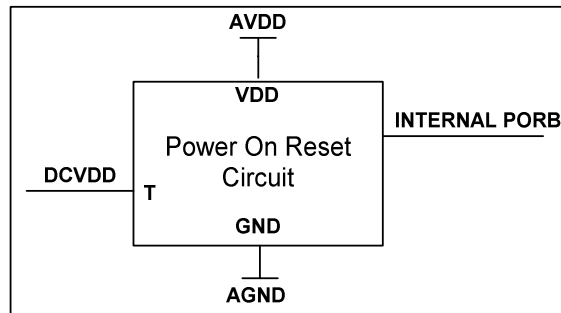

Figure 13 Internal Power on Reset Circuit Schematic

The WM8991 includes an internal Power-On-Reset Circuit, as shown in Figure 13, which is used to reset the digital logic into a default state after power up. The POR circuit is powered from AVDD and monitors DCVDD. It asserts PORB low if AVDD or DCVDD is below a minimum threshold.

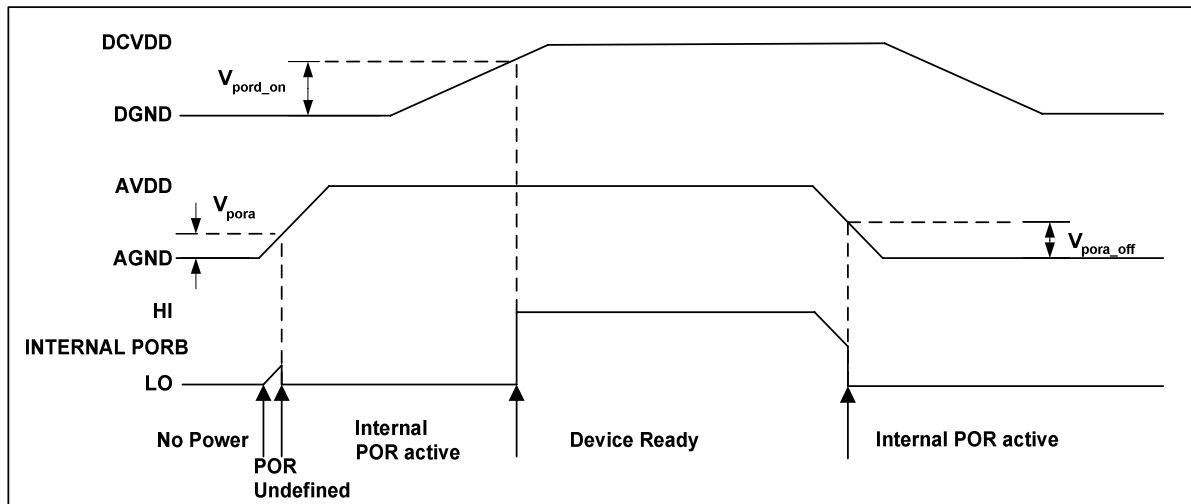

Figure 14 Typical Power up Sequence where AVDD is Powered before DCVDD

Figure 14 shows a typical power-up sequence where AVDD comes up first. When AVDD goes above the minimum threshold, V_{pora} , there is enough voltage for the circuit to guarantee PORB is asserted low and the chip is held in reset. In this condition, all writes to the control interface are ignored. Now AVDD is at full supply level. Next DCVDD rises to V_{pord_on} and PORB is released high and all registers are in their default state and writes to the control interface may take place.

On power down, where AVDD falls first, PORB is asserted low whenever AVDD drops below the minimum threshold V_{pora_off} .

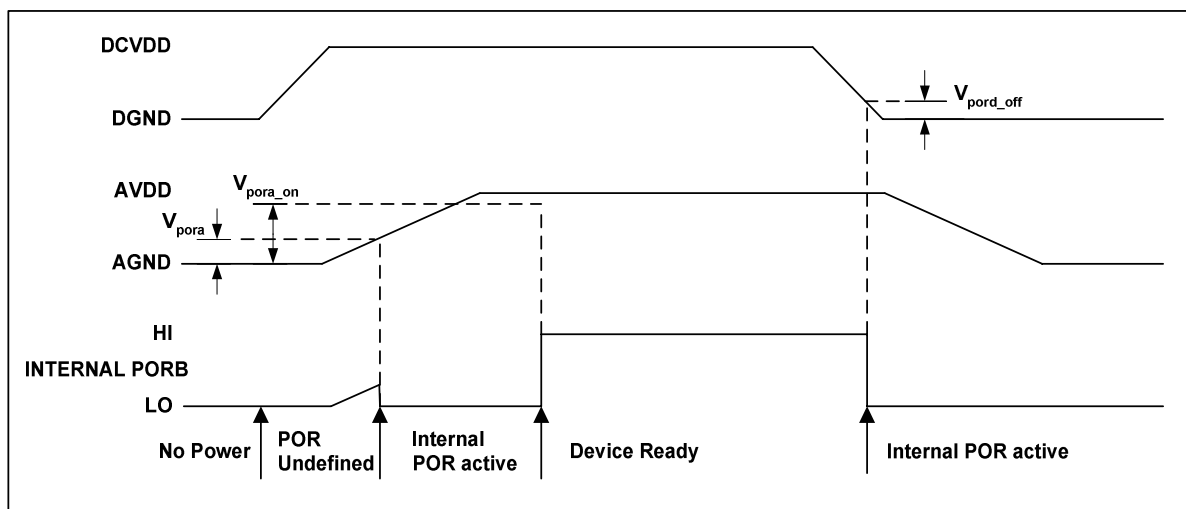

Figure 15 Typical Power up Sequence where DCVDD is powered before AVDD

Figure 15 shows a typical power-up sequence where DCVDD comes up first. First it is assumed that DCVDD is already up to specified operating voltage. When AVDD goes above the minimum threshold, V_{pora} , there is enough voltage for the circuit to guarantee PORB is asserted low and the chip is held in reset. In this condition, all writes to the control interface are ignored. When AVDD rises to V_{pora_on} , PORB is released high and all registers are in their default state and writes to the control interface may take place.

On power down, where DCVDD falls first, PORB is asserted low whenever DCVDD drops below the minimum threshold V_{pord_off} .

SYMBOL	MIN	TYP	MAX	UNIT
V_{pora}		0.6		V
V_{pora_on}		1.52		V
V_{pora_off}		1.5		V
V_{pord_on}		0.92		V
V_{pord_off}		0.9		V

Table 1 Typical POR Operation (typical values, not tested)

Notes:

1. If AVDD and DCVDD suffer a brown-out (i.e. drop below the minimum recommended operating level but do not go below V_{pora_off} or V_{pord_off}) then the chip will not reset and will resume normal operation when the voltage is back to the recommended level again.
2. The chip will enter reset at power down when AVDD or DCVDD falls below V_{pora_off} or V_{pord_off} . This may be important if the supply is turned on and off frequently by a power management system.
3. The minimum t_{por} period is maintained even if DCVDD and AVDD have zero rise time. This specification is guaranteed by design rather than test.

DEVICE DESCRIPTION

INTRODUCTION

The WM8991 is a low power, high quality audio codec designed to interface with a wide range of processors and analogue components. A high level of mixed-signal integration in a small 5x5mm footprint makes it ideal for portable applications such as mobile phones.

Eight highly flexible analogue inputs allow interfacing to up to four microphone inputs plus multiple stereo or mono line inputs (single-ended or differential). Connections to an external voice CODEC, FM radio, melody IC, line input, handset MIC and headset MIC are all fully supported. Signal routing to the output mixers and within the CODEC has been designed for maximum flexibility to support a wide variety of usage modes.

Ten analogue output drivers are integrated, including a high power, high quality speaker driver, capable of providing 1W in class D mode or in class AB mode into 8Ω BTL. Four headphone drivers are provided, supporting ear speakers and stereo headsets. Fully differential headphone drive is supported for excellent crosstalk performance and removing the need for large and expensive headphone capacitors. Four line outputs are available for Tx voice output to a voice CODEC, interfacing to an additional speaker driver and single-ended or fully differential line output. All outputs have integrated pop and click suppression. The speaker supply has been designed with low leakage and high PSRR, to support direct connection to a Lithium battery. In addition to the speaker PGA, six AC and DC gain settings allow output signal level to be maximised for many commonly-used SPKVDD/AVDD combinations.

Internal signal routing and amplifier configurations have been optimised to provide the lowest possible power consumption for a number of common usage scenarios such as voice calls and music playback.

The stereo ADCs and DACs are of hi-fi quality using a 24-bit, low-order oversampling architecture to deliver optimum performance. A flexible clocking arrangement supports mixed ADC and DAC sample rates, while an integrated ultra-low power PLL provides additional flexibility. A high pass filter is available in the ADC path for removing DC offsets and suppressing low frequency noise such as mechanical vibration and wind noise. A digital mixing path from the ADC to the DAC provides a sidetone of enhanced quality during voice calls. DAC soft mute and un-mute is available for pop-free music playback.

The WM8991 has a highly flexible digital audio interface, supporting a number of protocols, including I²S, DSP, MSB-First left/right justified, and can operate in master or slave modes. PCM operation is supported in the DSP mode. A-law and μ -law companding are also supported. Time division multiplexing (TDM) is available to allow multiple devices to stream data simultaneously on the same bus, saving space and power. Alternative DAC interface pins are provided to allow connection to an additional processor.

The SYSCLK (system clock) provides clocking for the ADCs, DACs, DSP core, class D outputs and the digital audio interface. SYSCLK can be derived directly from the MCLK pin or via an integrated PLL, providing flexibility to support a wide range of clocking schemes. All MCLK frequencies typically used in portable systems are supported for sample rates between 8kHz and 48kHz. A flexible switching clock for the class D speaker drivers (synchronous with the audio DSP clocks for best performance) is also derived from SYSCLK. An additional master clock input pin is provided, to support operation on an alternative clock domain, selectable via a de-glitch circuit.

To allow full software control over all its features, the WM8991 uses a standard 2-wire or 3/4-wire control interface with readback of key registers supported. It is fully compatible and an ideal partner for a wide range of industry standard microprocessors, controllers and DSPs. Unused circuitry can be disabled via software to save power, while low leakage currents extend standby and off time in portable battery-powered applications. The device address can be selected using the CSB/ADDR pin.

Versatile GPIO functionality is provided, with support for up to seven button/accessory detect inputs with interrupt and status readback and flexible de-bouncing options, clock output, alternative MCLK input, ADCLRC inversion for simultaneous streaming of ADC data to two separate processors and logic '1' / logic '0' for control of additional external circuitry.

INPUT SIGNAL PATH

The WM8991 has eight highly flexible analogue input channels, configurable in many combinations of the following:

1. Up to four pseudo-differential or single-ended microphone inputs
2. Up to eight mono line inputs or 4 stereo line inputs
3. Mono input from external voice CODEC
4. Two fully balanced differential inputs

These inputs may be mixed together or independently routed to different combinations of output drivers. An internal record path is provided at the input mixers to allow DAC output to be mixed with the input signal path (e.g. for karaoke or voice call recording).

The WM8991 input signal paths and control registers are illustrated in Figure 16.

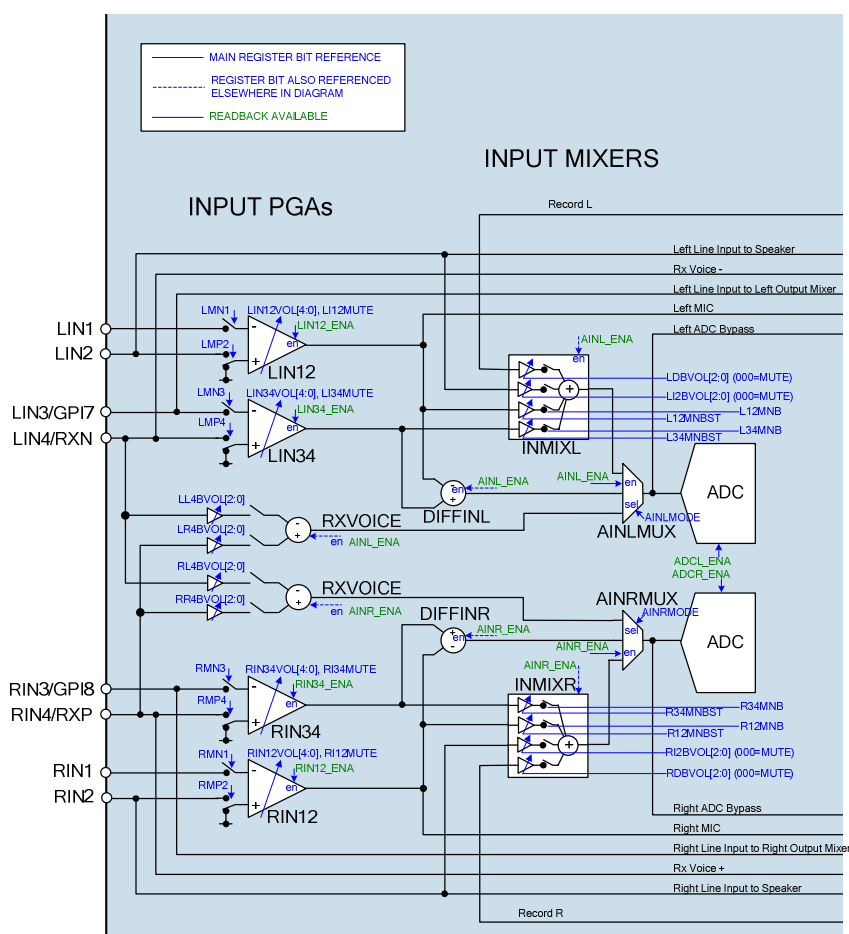

Figure 16 Control Registers for Input Signal Path

MICROPHONE INPUTS

Up to four microphones can be connected to the WM8991, either in single-ended or pseudo-differential mode. A low noise microphone bias is fully integrated to reduce the need for external components.

In single-ended microphone input configuration, the microphone signal is connected to the inverting input of the PGA (LIN1, LIN3, RIN1 or RIN3). The non-inverting input of the PGAs should be internally connected to VMID in this configuration. This is enabled via the Input PGA configuration register settings. In this configuration, LIN2, LIN4, RIN2 or RIN4 may be free to be used as line inputs or ADC bypass inputs.

In pseudo-differential microphone input configuration, the non-inverted microphone signal is connected to the non-inverting input of the PGA (LIN2, LIN4, RIN2 or RIN4) and the inverted (or noisy ground) signal is connected to the inverting input (LIN1, LIN3, RIN1 or RIN3).

Any PGA input pin that is used in either microphone configuration should not be enabled as a line input path at the same time.

The gain of the input PGAs is controlled via register settings. Note that the input impedance of LIN1, LIN3, RIN1 and RIN3 changes with the input PGA gain setting, as described under "Electrical Characteristics". (Note this does not apply to input paths which bypass the input PGA.) The input impedance of LIN2, LIN4, RIN2 and RIN4 does not change with input PGA gain. The inverting and non-inverting inputs are therefore not matched and the differential configuration is not fully differential.

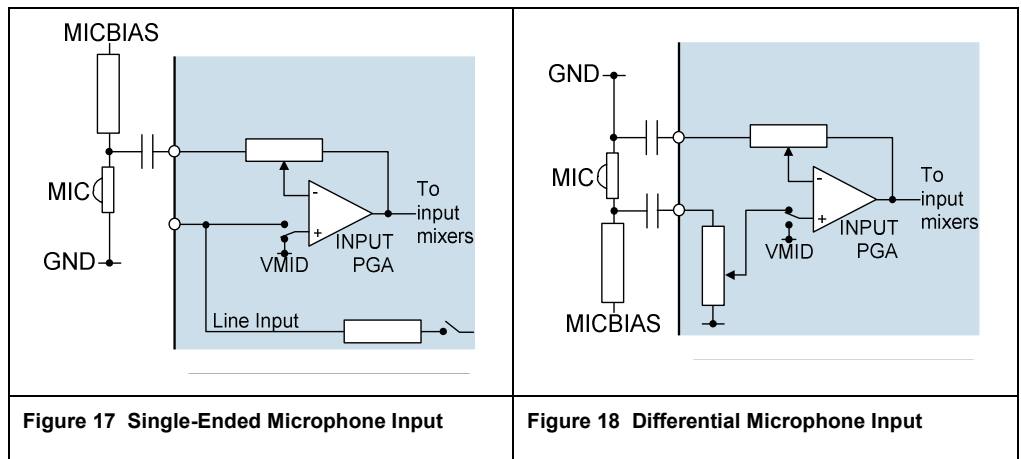

LINE INPUTS

All eight analogue input pins may be configured as line inputs. Various signal paths exist to provide flexibility, high performance and low power consumption for different usage modes.

LIN1 and RIN1 can operate as line inputs to the Input PGAs LIN12 and RIN12 to provide high gain if required for small input signals.

LIN2 and RIN2 can operate as line inputs directly to the input mixers or to the speaker output mixer. Direct routing to the speaker output minimises power consumption by reducing the number of active amplifiers in the signal path.

LIN3 and RIN3 can operate as line inputs to the Input PGAs or as a line input directly to either of the output mixers LOMIX and ROMIX.

LIN1+LIN3 and RIN1+RIN3 can also be used as fully balanced differential inputs via the Input PGAs to one of the input mixers. (Note that these inputs have matched input impedances.)

LIN4/RXN and RIN4/RXP can operate as line inputs directly to the outputs OUT3 and OUT4, providing an ultra-low power stereo or mono differential signal path (e.g. from an external voice CODEC) to an ear speaker. LIN4/RXN and RIN4/RXP can also operate as a mono differential input to the ADC input signal path and output mixer stages.

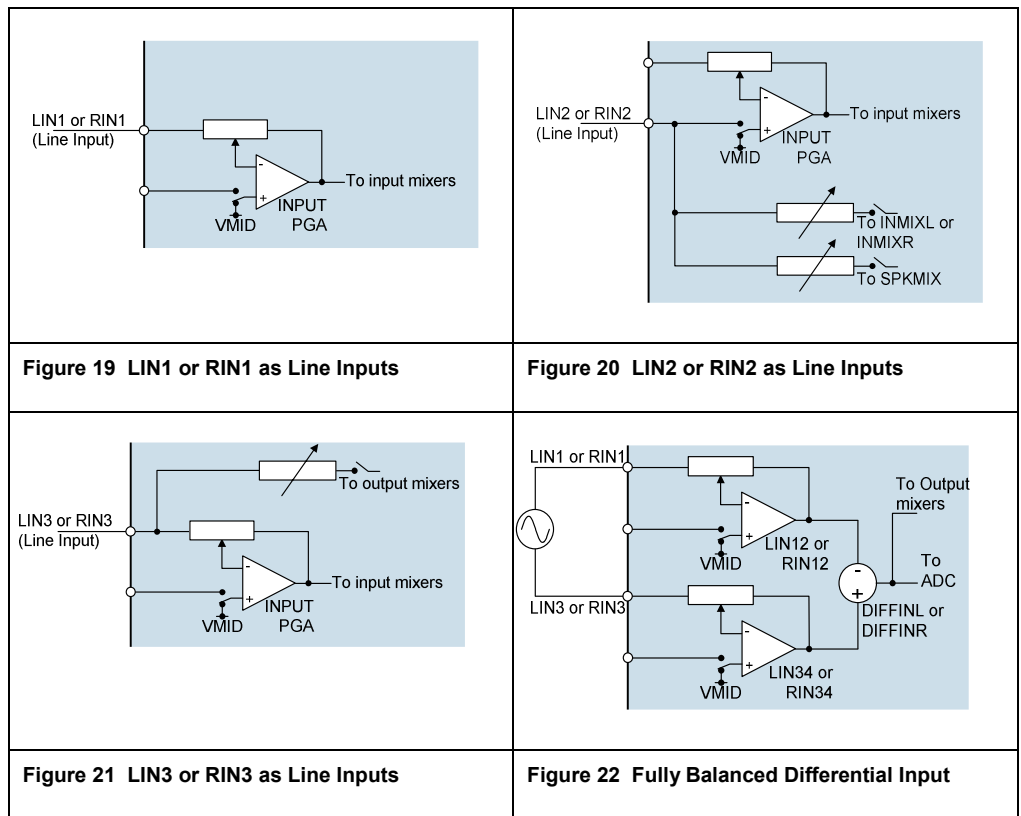

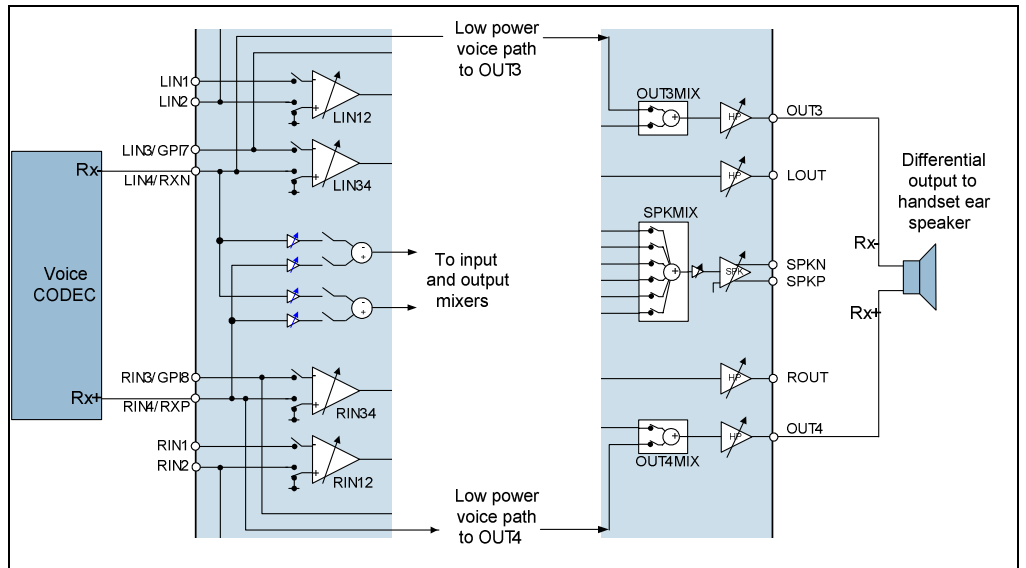

Figure 23 LIN4 and RIN4 as Rx Voice Inputs with Direct Low Power Path to Ear Speaker

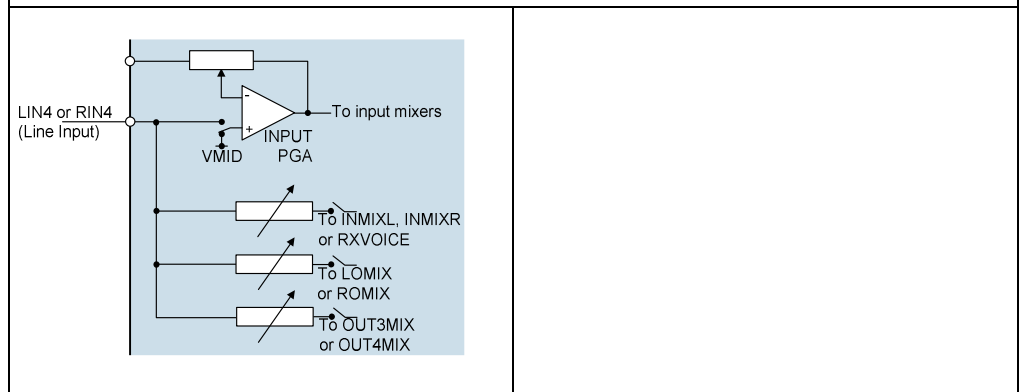

Figure 24 LIN4 or RIN4 as Line Inputs

INPUT PGA ENABLE

The Input PGAs are enabled using register bits LIN12_ENA, LIN34_ENA, RIN12_ENA and RIN34_ENA as described in Table 2.

REGISTER ADDRESS	BIT	LABEL	DEFAULT	DESCRIPTION
R2 (02h)	7	LIN34_ENA (rw)	0b	LIN34 Input PGA Enable 0 = disabled 1 = enabled
	6	LIN12_ENA (rw)	0b	LIN12 Input PGA Enable 0 = disabled 1 = enabled
	5	RIN34_ENA (rw)	0b	RIN34 Input PGA Enable 0 = disabled 1 = enabled
	4	RIN12_ENA (rw)	0b	RIN12 Input PGA Enable 0 = disabled 1 = enabled

Table 2 Input PGA Enable

To enable the input PGAs, the reference voltage VMID and the bias current must also be enabled. See "Power Management" for definitions of the associated controls VMID_MODE and VREF_ENA.

MICROPHONE BIAS CONTROL

The MICBIAS output provides a low noise reference voltage suitable for biasing electret type microphones via an external resistor. Refer to the Applications Information section for recommended external components. The MICBIAS voltage can be enabled or disabled using the MICBIAS_ENA control bit and the voltage can be selected using the MBSEL register bit as detailed in Table 3.

REGISTER ADDRESS	BIT	LABEL	DEFAULT	DESCRIPTION
R1 (01h)	4	MICBIAS_ENA (rw)	0b	Microphone Bias 0 = OFF (high impedance output) 1 = ON
R58 (3Ah)	0	MBSEL	0b	Microphone Bias Voltage Control 0 = 0.9 * AVDD 1 = 0.65 * AVDD

Table 3 Microphone Bias Control

Note that the maximum source current capability for MICBIAS is 3mA. The external biasing resistance must be large enough to limit the MICBIAS current to 3mA.

MICROPHONE CURRENT DETECT

A MICBIAS current detect function allows detection of accessories such as headset microphones. When the MICBIAS load current exceeds one of two programmable thresholds, (e.g. short circuit current or normal operating current), an interrupt or GPIO output can be generated. The current detection circuit is enabled by the MCD bit; the current thresholds are selected by the MCDTHR and MCDSCSTH register fields as described in Table 49- see "General Purpose Input/Output" for a full description of these fields.

INPUT PGA CONFIGURATION

Each of the four Input PGAs can be configured in single-ended or pseudo-differential mode.

Single-ended microphone operation of an Input PGA is selected by connecting the input source to the inverting PGA input. The non-inverting PGA input must be connected to VMID by setting the appropriate register bits.

For pseudo-differential microphone operation, the inverting and non-inverting PGA inputs are both connected to the input source and not to VMID.

For any line input or other connection not using the Input PGA, the appropriate PGA input should be disconnected from the external pin and connected to VMID.

Register bits LMN1, LMP2, LMN3, LMP4, RMN1, RMP2, RMN3 and RMP4 control connection of the PGA inputs to the device pins as shown in Table 4. The maximum available attenuation on any of these input paths is achieved using these bits to disable the input path to the applicable PGA.

When not enabled as analogue inputs or as General Purpose inputs, the input pins can be biased to VREF via a 1k Ω resistor by setting the BUFIOEN bit. See "Pop Suppression Control" for details.

REGISTER ADDRESS	BIT	LABEL	DEFAULT	DESCRIPTION
R40 (28h)	7	LMP4	0b	LIN34 PGA Non-Inverting Input Select 0 = LIN4 not connected to PGA 1 = LIN4 connected to PGA
	6	LMN3	0b	LIN34 PGA Inverting Input Select 0 = LIN3 not connected to PGA 1 = LIN3 connected to PGA
	5	LMP2	0b	LIN12 PGA Non-Inverting Input Select 0 = LIN2 not connected to PGA 1 = LIN2 connected to PGA
	4	LMN1	0b	LIN12 PGA Inverting Input Select 0 = LIN1 not connected to PGA 1 = LIN1 connected to PGA
	3	RMP4	0b	RIN34 PGA Non-Inverting Input Select 0 = RIN4 not connected to PGA 1 = RIN4 connected to PGA
	2	RMN3	0b	RIN34 PGA Inverting Input Select 0 = RIN3 not connected to PGA 1 = RIN3 connected to PGA
	1	RMP2	0b	RIN12 PGA Non-Inverting Input Select 0 = RIN2 not connected to PGA 1 = RIN2 connected to PGA
	0	RMN1	0b	RIN12 PGA Inverting Input Select 0 = RIN1 not connected to PGA 1 = RIN1 connected to PGA

Table 4 Input PGA Configuration

INPUT PGA VOLUME CONTROL

Each of the four Input PGAs has an independently controlled gain range of -16.5dB to +30dB in 1.5dB steps. The gains on the inverting and non-inverting inputs to the PGAs are always equal. Each Input PGA can be independently muted using the PGA mute bits as described in Table 5, with specified mute attenuation achieved by simultaneously disconnecting the corresponding inputs described in Table 4.

To prevent "zipper noise", a zero-cross function is provided, so that when enabled, volume updates will not take place until a zero-crossing is detected. In the event of a long period without zero-crossings, a timeout function is available. When this function is enabled (using the TOCLK_ENA register bit), the volume will update after the timeout period if no earlier zero-cross has occurred. The timeout period is set by TOCLK_RATE. See "Clocking and Sample Rates" for more information on these fields.

The IPVU bit controls the loading of the input PGA volume data. When IPVU is set to 0, the PGA volume data will be loaded into the respective control register, but will not actually change the gain setting. The LIN12, RIN12, LIN34, RIN34 volume settings are all updated when a 1 is written to IPVU. This makes it possible to update the gain of all input paths simultaneously.

The Input PGA Volume Control register fields are described in Table 5 and Table 6.

REGISTER ADDRESS	BIT	LABEL	DEFAULT	DESCRIPTION
R24 (18h)	8	IPVU[0]	N/A	Input PGA Volume Update Writing a 1 to this bit will cause all input PGA volumes to be updated simultaneously (LIN12, LIN34, RIN12 and RIN34)
	7	LI12MUTE	1b	LIN12 PGA Mute 0 = Disable Mute 1 = Enable Mute
	6	LI12ZC	0b	LIN12 PGA Zero Cross Detector 0 = Change gain immediately 1 = Change gain on zero cross only
	4:0	LIN12VOL [4:0]	01011b (0dB)	LIN12 Volume (See Table 6 for volume range)
R25 (19h)	8	IPVU[1]	N/A	Input PGA Volume Update Writing a 1 to this bit will cause all input PGA volumes to be updated simultaneously (LIN12, LIN34, RIN12 and RIN34)
	7	LI34MUTE	1b	LIN34 PGA Mute 0 = Disable Mute 1 = Enable Mute
	6	LI34ZC	0b	LIN34 PGA Zero Cross Detector 0 = Change gain immediately 1 = Change gain on zero cross only
	4:0	LIN34VOL [4:0]	01011b (0dB)	LIN34 Volume (See Table 6 for volume range)
R26 (1Ah)	8	IPVU[2]	N/A	Input PGA Volume Update Writing a 1 to this bit will cause all input PGA volumes to be updated simultaneously (LIN12, LIN34, RIN12 and RIN34)
	7	RI12MUTE	1b	RIN12 PGA Mute 0 = Disable Mute 1 = Enable Mute
	6	RI12ZC	0b	RIN12 PGA Zero Cross Detector 0 = Change gain immediately 1 = Change gain on zero cross only

REGISTER ADDRESS	BIT	LABEL	DEFAULT	DESCRIPTION
	4:0	RIN12VOL [4:0]	01011b (0dB)	RIN12 Volume (See Table 6 for volume range)
R27 (1Bh)	8	IPVU[3]	N/A	Input PGA Volume Update Writing a 1 to this bit will cause all input PGA volumes to be updated simultaneously (LIN12, LIN34, RIN12 and RIN34)
	7	RI34MUTE	1b	RIN34 PGA Mute 0 = Disable Mute 1 = Enable Mute
	6	RI34ZC	0b	RIN34 PGA Zero Cross Detector 0 = Change gain immediately 1 = Change gain on zero cross only
	4:0	RIN34VOL [4:0]	01011b (0dB)	RIN34 Volume (See Table 6 for volume range)

Table 5 Input PGA Volume Control

LIN12VOL[4:0], LIN34VOL[4:0], RIN12VOL[4:0], RIN34VOL[4:0]	VOLUME (dB)
00000	-16.5
00001	-15.0
00010	-13.5
00011	-12.0
00100	-10.5
00101	-9.0
00110	-7.5
00111	-6.0
01000	-4.5
01001	-3.0
01010	-1.5
01011	0
01100	+1.5
01101	+3.0
01110	+4.5
01111	+6.0
10000	+7.5
10001	+9.0
10010	+10.5
10011	+12.0
10100	+13.5
10101	+15.0
10110	+16.5
10111	+18.0
11000	+19.5
11001	+21.0
11010	+22.5
11011	+24.0
11100	+25.5
11101	+27.0
11110	+28.5
11111	+30.0

Table 6 Input PGA Volume Range

INPUT MIXER ENABLE

The WM8991 has two analogue input mixers which allow the Input PGAs and Line Inputs to be combined in a number of ways and output to the ADCs or to the Output Mixers via bypass paths.

The input mixers INMIXL and INMIXR are enabled by the AINL_ENA and AINR_ENA register bits, as described in Table 7. These control bits also enable the Input Multiplexers and Differential Input drivers, described in the following section.

REGISTER ADDRESS	BIT	LABEL	DEFAULT	DESCRIPTION
R2 (02h)	9	AINL_ENA (rw)	0b	Left Input Path Enable (Enables AINLMUX, INMIXL, DIFFINL and RXVOICE input to AINLMUX) 0 = Input Path disabled 1 = Input Path enabled
	8	AINR_ENA (rw)	0b	Right Input Path Enable (Enables AINRMUX, INMIXR, DIFFINR and RXVOICE input to AINRMUX) 0 = Input Path disabled 1 = Input Path enabled

Table 7 Input Mixer Enable

INPUT MIXER CONFIGURATION

The left and right channel input multiplexers AINLMUX and AINRMUX select one of three input sources for the Left and Right channels independently. The three input sources are as follows:

1. INMIXL or INMIXR output (a combination of Input PGAs, line inputs and the internal record path).
2. RXVOICE (a differential to single-ended conversion of RXP and RXN inputs).
3. DIFFINL or DIFFINR output (a differential to single-ended conversion of two Input PGAs).

The input source for the multiplexers is controlled by register bits AINLMODE and AINRMODE as described in Table 8.

REGISTER ADDRESS	BIT	LABEL	DEFAULT	DESCRIPTION
R39 (27h)	3:2	AINLMODE [1:0]	00b	AINLMUX Input Source 00 = INMIXL (Left Input Mixer) 01 = RXVOICE (RXP - RXN) 10 = DIFFINL (LIN12 PGA - LIN34 PGA) 11 = (Reserved)
	1:0	AINRMODE [1:0]	00b	AINRMUX Input Source 00 = INMIXR (Right Input Mixer) 01 = RXVOICE (RXP - RXN) 10 = DIFFINR (RIN12 PGA - RIN34 PGA) 11 = (Reserved)

Table 8 Input Mixer Configuration

The Input Mixer configuration is described for each of the three modes in the following sections. Note that the Left and Right multiplexer (mode) settings can be set independently.

In Mixer Mode (AINLMODE=00, AINRMODE=00), adjustable gain control is available on the input mixers INMIXL and INMIXR for all available input signals (PGA outputs, line inputs and record paths). This configuration is illustrated in Figure 25. The applicable register settings are shown in Table 9.

CONFIGURATION	REGISTER SETTINGS	
Left Channel Mixer Mode (INMIXL to AINLMUX)	1. Select Mixer Mode	AINLMODE = 00
	2. Enable input paths as required (see Table 5 and Table 12 for full definitions of the applicable settings listed here)	L12MNB, L12MNBST LIN12VOL, LIN12MUTE L34MNB, L34MNBST LIN34VOL, LIN34MUTE LDBVOL LI2BVOL
Right Channel Mixer Mode (INMIXR to AINRMUX)	1. Select Mixer Mode	AINRMODE = 00
	2. Enable input paths as required (see Table 5 and Table 13 for full definitions of the applicable settings listed here)	R12MNB, R12MNBST RIN12VOL, RIN12MUTE R34MNB, R34MNBST RIN34VOL, RIN34MUTE RDBVOL RI2BVOL

Table 9 Mixer Mode Register Settings

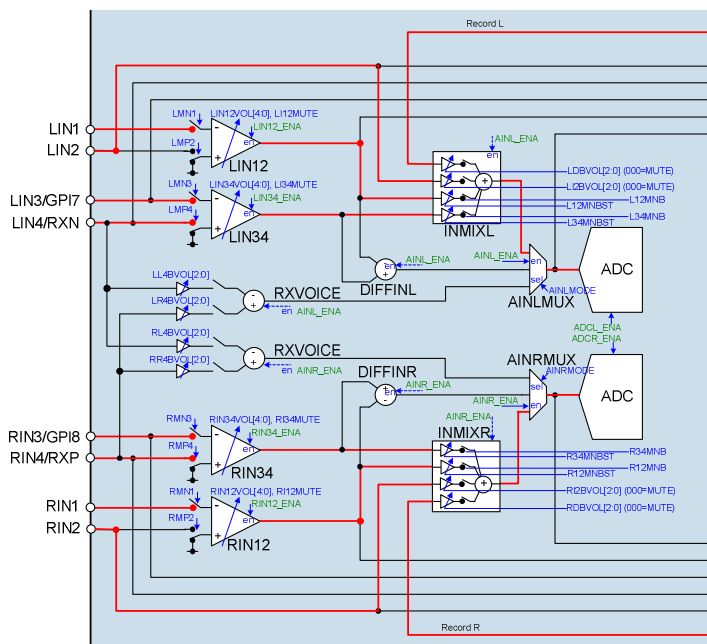

Figure 25 Mixer Mode Signal Paths

In Rx Voice Mode (AINLMODE=01, AINRMODE=01), adjustable gain control is available for the RXVOICE output by use of the LR4BVOL[2:0] and LL4BVOL[2:0] register fields on the left channel and by RL4BVOL[2:0] and RR4BVOL[2:0] on the right channel. Both Volume fields for the desired channel(s) must be set to the same value for true Differential input characteristics. This configuration is illustrated in Figure 26. The applicable register settings are shown in Table 10.

CONFIGURATION	REGISTER SETTINGS	
Left Channel Rx Voice Mode (RXVOICE to AINLMUX)	1. Select Rx Voice Mode	AINLMODE = 01
	2. Enable Rx Voice input as required Important: These two register fields must be set to the same value. See Table 12 for full definitions of these fields.	LL4BVOL LR4BVOL
Right Channel Rx Voice Mode (RXVOICE to AINRMUX)	1. Select Rx Voice Mode	AINRMODE = 01
	2. Enable Rx Voice input as required Important: These two register fields must be set to the same value. See Table 13 for full definitions of these fields.	RL4BVOL RR4BVOL

Table 10 RxVoice Mode Register Settings

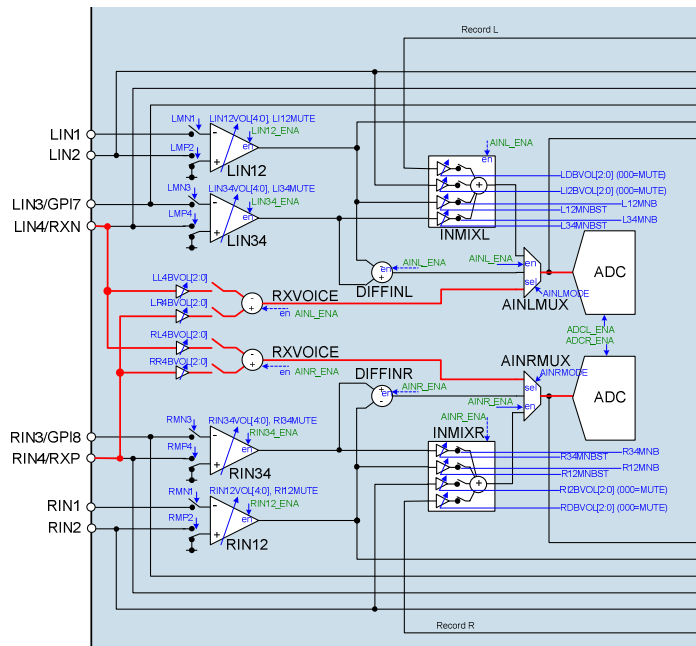

Figure 26 RxVoice Mode Signal Paths

In Differential Mode (AINLMODE=10, AINRMODE=10), no additional volume control is available in the input signal path, but the Input PGA volume control can be used to adjust the signal level as with other modes. Both PGAs on the desired channel(s) must be enabled, and the PGA volumes of each set to the same value for true Differential input characteristics. The PGA Output (LIN12 or RIN12) to Mixer (INMIXL or INMIXR) path must also be enabled on the desired channel(s) by use of register bit L12MNB or R12MNB. This configuration is illustrated in Figure 27. The applicable register settings are shown in Table 11.

CONFIGURATION	REGISTER SETTINGS	
Left Channel Differential Mode (DIFFINL to AINLMUX)	1. Select Differential Mode	AINLMODE = 10
	2. Enable LIN12 input path	L12MNB = 1
	3. Set channel volume as required. Important: The LIN12 and LIN34 volume and mute settings must be set to the same value. See Table 5 for full definitions of these fields.	LIN12VOL, LIN12MUTE LIN34VOL, LIN34MUTE
Right Channel Differential Mode (DIFFINR to AINRMUX)	1. Select Differential Mode	AINRMODE = 10
	2. Enable RIN12 input path	R12MNB = 1
	3. Set channel volume as required. Important: The RIN12 and RIN34 volume and mute settings must be set to the same value. See Table 5 for full definitions of these fields.	RIN12VOL, RIN12MUTE RIN34VOL, RIN34MUTE

Table 11 Differential Mode Register Settings

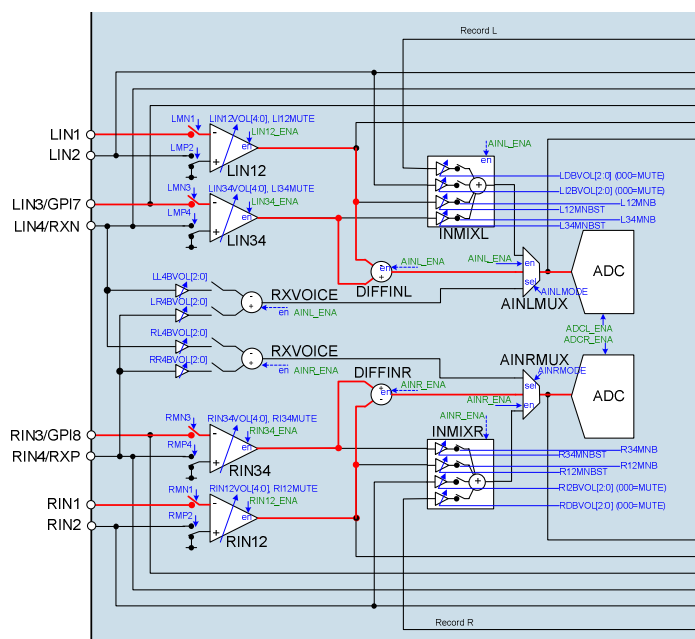

Figure 27 Differential Mode Signal Paths

INPUT MIXER VOLUME CONTROL

The Input Mixer volume controls are described in Table 12 for the Left Channel and Table 13 for the Right Channel. The Input PGA levels may be set to Mute, 0dB or 30dB boost. The other gain controls provide adjustment from -12dB to +6dB in 3dB steps.

To prevent pop noise it is recommended that gain and mute controls for the input mixers are not modified while the signal paths are active. If volume control is required on the input signal path it is recommended that the input PGA volume controls or the ADC volume controls are used instead of the input mixer gain registers.

REGISTER ADDRESS	BIT	LABEL	DEFAULT	DESCRIPTION
R41 (29h)	8	L34MNB	0b	LIN34 PGA Output to INMIXL Mute 0 = Mute 1 = Un-Mute
	7	L34MNBST	0b	LIN34 PGA Output to INMIXL Gain 0 = 0dB 1 = +30dB
	5	L12MNB	0b	LIN12 PGA Output to INMIXL Mute 0 = Mute 1 = Un-Mute
	4	L12MNBST	0b	LIN12 PGA Output to INMIXL Gain 0 = 0dB 1 = +30dB
	2:0	LDBVOL [2:0]	000b (Mute)	LOMIX to INMIXL Gain and Mute 000 = Mute 001 = -12dB 010 = -9dB 011 = -6dB 100 = -3dB 101 = 0dB 110 = +3dB 111 = +6dB
R43 (2Bh)	8:6	LI2BVOL [2:0]	000b (Mute)	LIN2 Pin to INMIXL Gain and Mute 000 = Mute 001 = -12dB 010 = -9dB 011 = -6dB 100 = -3dB 101 = 0dB 110 = +3dB 111 = +6dB
	5:3	LR4BVOL [2:0]	000b (Mute)	RXVOICE to AINLMUX Gain and Mute 000 = Mute 001 = -12dB 010 = -9dB 011 = -6dB 100 = -3dB 101 = 0dB 110 = +3dB 111 = +6dB
	2:0	LL4BVOL [2:0]	000b (Mute)	RXVOICE to INMIXL Gain and Mute 000 = Mute 001 = -12dB 010 = -9dB 011 = -6dB 100 = -3dB 101 = 0dB 110 = +3dB 111 = +6dB Note - LR4BVOL must be set to the same value as LL4BVOL when AINLMODE=01.

Table 12 Left Input Mixer Volume Control

REGISTER ADDRESS	BIT	LABEL	DEFAULT	DESCRIPTION
R42 (2A)	8	R34MNB	0b	RIN34 PGA Output to INMIXR Mute 0 = Mute 1 = Un-Mute
	7	R34MNBST	0b	RIN34 PGA Output to INMIXR Gain 0 = 0dB 1 = +30dB
	5	R12MNB	0b	RIN12 PGA Output to INMIXR Mute 0 = Mute 1 = Un-Mute
	4	R12MNBST	0b	RIN12 PGA Output to INMIXR Gain 0 = 0dB 1 = +30dB
	2:0	RDBVOL [2:0]	000b (Mute)	ROMIX to INMIXR Gain and Mute 000 = Mute 001 = -12dB 010 = -9dB 011 = -6dB 100 = -3dB 101 = 0dB 110 = +3dB 111 = +6dB
R44 (2Ch)	8:6	RI2BVOL [2:0]	000b (Mute)	RIN2 Pin to INMIXR Gain and Mute 000 = Mute 001 = -12dB 010 = -9dB 011 = -6dB 100 = -3dB 101 = 0dB 110 = +3dB 111 = +6dB
	5:3	RL4BVOL [2:0]	000b (Mute)	RXVOICE to AINRMUX Gain and Mute 000 = Mute 001 = -12dB 010 = -9dB 011 = -6dB 100 = -3dB 101 = 0dB 110 = +3dB 111 = +6dB
	2:0	RR4BVOL [2:0]	000b (Mute)	RXVOICE to INMIXR Gain and Mute 000 = Mute 001 = -12dB 010 = -9dB 011 = -6dB 100 = -3dB 101 = 0dB 110 = +3dB 111 = +6dB Note - RL4BVOL must be set to the same value as RR4BVOL when AINRMODE=01.

Table 13 Right Input Mixer Volume Control

ANALOGUE TO DIGITAL CONVERTER (ADC)

The WM8991 uses stereo 24-bit, 64x oversampled sigma-delta ADCs. The use of multi-bit feedback and high oversampling rates reduces the effects of jitter and high frequency noise. The ADC full scale input level is proportional to AVDD. See “Electrical Characteristics” for further details. Any input signal greater than full scale may overload the ADC and cause distortion.

The ADCs are enabled by the ADCL_ENA and ADCR_ENA register bits.

REGISTER ADDRESS	BIT	LABEL	DEFAULT	DESCRIPTION
R2 (02h)	1	ADCL_ENA (rw)	0b	Left ADC Enable 0 = ADC disabled 1 = ADC enabled
	0	ADCR_ENA (rw)	0b	Right ADC Enable 0 = ADC disabled 1 = ADC enabled

Table 14 ADC Enable Control

ADC DIGITAL VOLUME CONTROL

The output of the ADCs can be digitally amplified or attenuated over a range from -71.625dB to +17.625dB in 0.375dB steps. The volume of each channel can be controlled separately. The gain for a given eight-bit code X is given by:

$$0.375 \times (X-192) \text{ dB for } 1 \leq X \leq 239; \quad \text{MUTE for } X = 0 \quad +17.625\text{dB for } 239 \leq X \leq 255$$

The ADC_VU bit controls the loading of digital volume control data. When ADC_VU is set to 0, the ADCL_VOL or ADCR_VOL control data will be loaded into the respective control register, but will not actually change the digital gain setting. Both left and right gain settings are updated when a 1 is written to ADC_VU. This makes it possible to update the gain of both channels simultaneously.

REGISTER ADDRESS	BIT	LABEL	DEFAULT	DESCRIPTION
R15 (0Fh)	8	ADC_VU	N/A	ADC Volume Update Writing a 1 to this bit will cause left and right ADC volume to be updated simultaneously
	7:0	ADCL_VOL [7:0]	1100_0000b (0dB)	Left ADC Digital Volume (See Table 16 for volume range)
R16 (10h)	8	ADC_VU	N/A	ADC Volume Update Writing a 1 to this bit will cause left and right ADC volume to be updated simultaneously
	7:0	ADCR_VOL [7:0]	1100_0000b (0dB)	Right ADC Digital Volume (See Table 16 for volume range)

Table 15 ADC Digital Volume Control

ADCL_VOL or ADCR_VOL	Volume (dB)	ADCL_VOL or ADCR_VOL	Volume (dB)	ADCL_VOL or ADCR_VOL	Volume (dB)	ADCL_VOL or ADCR_VOL	Volume (dB)
0h	MUTE	40h	-48.000	80h	-24.000	C0h	0.000
1h	-71.625	41h	-47.625	81h	-23.625	C1h	0.375
2h	-71.250	42h	-47.250	82h	-23.250	C2h	0.750
3h	-70.875	43h	-46.875	83h	-22.875	C3h	1.125
4h	-70.500	44h	-46.500	84h	-22.500	C4h	1.500
5h	-70.125	45h	-46.125	85h	-22.125	C5h	1.875
6h	-69.750	46h	-45.750	86h	-21.750	C6h	2.250
7h	-69.375	47h	-45.375	87h	-21.375	C7h	2.625
8h	-69.000	48h	-45.000	88h	-21.000	C8h	3.000
9h	-68.625	49h	-44.625	89h	-20.625	C9h	3.375
Ah	-68.250	4Ah	-44.250	8Ah	-20.250	CAh	3.750
Bh	-67.875	4Bh	-43.875	8Bh	-19.875	CBh	4.125
Ch	-67.500	4Ch	-43.500	8Ch	-19.500	CCh	4.500
Dh	-67.125	4Dh	-43.125	8Dh	-19.125	CDh	4.875
Eh	-66.750	4Eh	-42.750	8Eh	-18.750	CEh	5.250
Fh	-66.375	4Fh	-42.375	8Fh	-18.375	CFh	5.625
10h	-66.000	50h	-42.000	90h	-18.000	D0h	6.000
11h	-65.625	51h	-41.625	91h	-17.625	D1h	6.375
12h	-65.250	52h	-41.250	92h	-17.250	D2h	6.750
13h	-64.875	53h	-40.875	93h	-16.875	D3h	7.125
14h	-64.500	54h	-40.500	94h	-16.500	D4h	7.500
15h	-64.125	55h	-40.125	95h	-16.125	D5h	7.875
16h	-63.750	56h	-39.750	96h	-15.750	D6h	8.250
17h	-63.375	57h	-39.375	97h	-15.375	D7h	8.625
18h	-63.000	58h	-39.000	98h	-15.000	D8h	9.000
19h	-62.625	59h	-38.625	99h	-14.625	D9h	9.375
1Ah	-62.250	5Ah	-38.250	9Ah	-14.250	DAh	9.750
1Bh	-61.875	5Bh	-37.875	9Bh	-13.875	DBh	10.125
1Ch	-61.500	5Ch	-37.500	9Ch	-13.500	DCh	10.500
1Dh	-61.125	5Dh	-37.125	9Dh	-13.125	DDh	10.875
1Eh	-60.750	5Eh	-36.750	9Eh	-12.750	DEh	11.250
1Fh	-60.375	5Fh	-36.375	9Fh	-12.375	DFh	11.625
20h	-60.000	60h	-36.000	A0h	-12.000	E0h	12.000
21h	-59.625	61h	-35.625	A1h	-11.625	E1h	12.375
22h	-59.250	62h	-35.250	A2h	-11.250	E2h	12.750
23h	-58.875	63h	-34.875	A3h	-10.875	E3h	13.125
24h	-58.500	64h	-34.500	A4h	-10.500	E4h	13.500
25h	-58.125	65h	-34.125	A5h	-10.125	E5h	13.875
26h	-57.750	66h	-33.750	A6h	-9.750	E6h	14.250
27h	-57.375	67h	-33.375	A7h	-9.375	E7h	14.625
28h	-57.000	68h	-33.000	A8h	-9.000	E8h	15.000
29h	-56.625	69h	-32.625	A9h	-8.625	E9h	15.375
2Ah	-56.250	6Ah	-32.250	AAh	-8.250	EAh	15.750
2Bh	-55.875	6Bh	-31.875	ABh	-7.875	EBh	16.125
2Ch	-55.500	6Ch	-31.500	ACH	-7.500	ECh	16.500
2Dh	-55.125	6Dh	-31.125	ADh	-7.125	EDh	16.875
2Eh	-54.750	6Eh	-30.750	A Eh	-6.750	EEh	17.250
2Fh	-54.375	6Fh	-30.375	AFh	-6.375	EFh	17.625
30h	-54.000	70h	-30.000	B0h	-6.000	F0h	17.625
31h	-53.625	71h	-29.625	B1h	-5.625	F1h	17.625
32h	-53.250	72h	-29.250	B2h	-5.250	F2h	17.625
33h	-52.875	73h	-28.875	B3h	-4.875	F3h	17.625
34h	-52.500	74h	-28.500	B4h	-4.500	F4h	17.625
35h	-52.125	75h	-28.125	B5h	-4.125	F5h	17.625
36h	-51.750	76h	-27.750	B6h	-3.750	F6h	17.625
37h	-51.375	77h	-27.375	B7h	-3.375	F7h	17.625
38h	-51.000	78h	-27.000	B8h	-3.000	F8h	17.625
39h	-50.625	79h	-26.625	B9h	-2.625	F9h	17.625
3Ah	-50.250	7Ah	-26.250	BAh	-2.250	FAh	17.625
3Bh	-49.875	7Bh	-25.875	BBh	-1.875	FBh	17.625
3Ch	-49.500	7Ch	-25.500	BCh	-1.500	FCh	17.625
3Dh	-49.125	7Dh	-25.125	BDh	-1.125	FDh	17.625
3Eh	-48.750	7Eh	-24.750	BEh	-0.750	FEh	17.625
3Fh	-48.375	7Fh	-24.375	BFh	-0.375	FFh	17.625

Table 16 ADC Digital Volume Range

HIGH PASS FILTER

A digital high pass filter is applied by default to the ADC path to remove DC offsets. This filter can also be programmed to remove low frequency noise in voice applications (e.g. wind noise or mechanical vibration). This filter is controlled using the ADC_HPF_ENA and ADC_HPF_CUT register bits.

In hi-fi mode the high pass filter is optimised for removing DC offsets without degrading the bass response and has a cut-off frequency of 3.7Hz at fs=44.1kHz.

In voice mode the high pass filter is optimised for voice communication and it is recommended to program the cut-off frequency below 300Hz (e.g. ADC_HPF_CUT=11 at fs=8kHz or ADC_HPF_CUT=10 at fs=16kHz).

REGISTER ADDRESS	BIT	LABEL	DEFAULT	DESCRIPTION
R14 (0Eh)	8	ADC_HPF_ENA	1b	ADC Digital High Pass Filter Enable 0 = disabled 1 = enabled
	6:5	ADC_HPF_CUT [1:0]	00b	ADC Digital High Pass Filter Cut-Off Frequency (fc) 00 = Hi-fi mode (fc=4Hz at fs=48kHz) 01 = Voice mode 1 (fc=127Hz at fs=16kHz) 10 = Voice mode 2 (fc=130Hz at fs=8kHz) 11 = Voice mode 3 (fc=267Hz at fs=8kHz) (Note: fc scales with sample rate. See Table 18 for cut-off frequencies at all supported sample rates)

Table 17 ADC High Pass Filter Control Registers

SAMPLE FREQUENCY (kHz)	CUT-OFF FREQUENCY (Hz)			
	ADC_HPF_CUT =00	ADC_HPF_CUT =01	ADC_HPF_CUT =10	ADC_HPF_CUT =11
8.000	0.7	64	130	267
11.025	0.9	88	178	367
16.000	1.3	127	258	532
22.050	1.9	175	354	733
24.000	2.0	190	386	798
32.000	2.7	253	514	1063
44.100	3.7	348	707	1464
48.000	4.0	379	770	1594

Table 18 ADC High Pass Filter Cut-Off Frequencies

The high pass filter characteristics are shown in the "Digital Filter Characteristics" section.

DIGITAL MIXING

The ADC and DAC data can be combined in various ways to support a range of different usage modes.

Data from either of the two ADCs can be routed to either the left or the right channel of the digital audio interface. In addition, data from either of the digital audio interface channels can be routed to either the left or the right DAC. See "Digital Audio Interface" for more information on the audio interface.

DIGITAL MIXING PATHS

Figure 28 shows the digital mixing paths available in the WM8991 digital core.

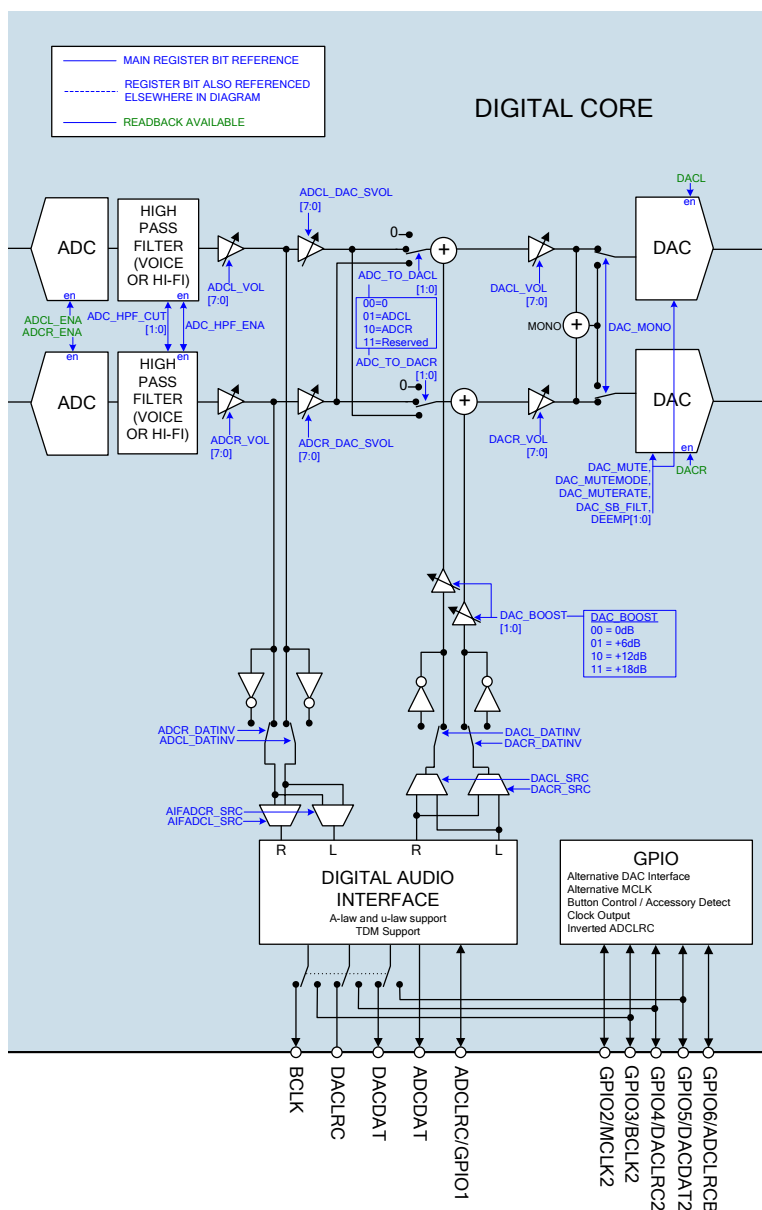

Figure 28 Digital Mixing Paths

The polarity of each ADC output signal can be changed under software control using the ADCL_DATINV and ADCR_DATINV register bits. The AIFADCL_SRC and AIFADCR_SRC register bits may be used to select which ADC is used for the left and right digital audio interface data. These register bits are described in Table 19.

REGISTER ADDRESS	BIT	LABEL	DEFAULT	DESCRIPTION
R4 (04h)	15	AIFADCL_SRC	0b	Left Digital Audio channel source 0 = Left ADC data is output on left channel 1 = Right ADC data is output on left channel
	14	AIFADCR_SRC	1b	Right Digital Audio channel source 0 = Left ADC data is output on right channel 1 = Right ADC data is output on right channel
R14 (0Eh)	1	ADCL_DATINV	0b	Left ADC Invert 0 = Left ADC output not inverted 1 = Left ADC output inverted
	0	ADCR_DATINV	0b	Right ADC Invert 0 = Right ADC output not inverted 1 = Right ADC output inverted

Table 19 ADC Routing and Control

The input data source for each DAC can be changed under software control using register bits DACL_SRC and DACR_SRC. The polarity of each DAC input may also be modified using register bits DACL_DATINV and DACR_DATINV. These register bits are described in Table 20.

REGISTER ADDRESS	BIT	LABEL	DEFAULT	DESCRIPTION
R5 (05h)	15	DACL_SRC	0b	Left DAC Data Source Select 0 = Left DAC outputs left channel data 1 = Left DAC outputs right channel data
	14	DACR_SRC	1b	Right DAC Data Source Select 0 = Right DAC outputs left channel data 1 = Right DAC outputs right channel data
R10 (0Ah)	1	DACL_DATINV	0b	Left DAC Invert 0 = Left DAC output not inverted 1 = Left DAC output inverted
	0	DACR_DATINV	0b	Right DAC Invert 0 = Right DAC output not inverted 1 = Right DAC output inverted

Table 20 DAC Routing and Control

DAC INTERFACE VOLUME BOOST

A digital gain function is available at the audio interface to boost the DAC volume when a small signal is received on DACDAT. This is controlled using register bits DAC_BOOST[1:0]. To prevent clipping at the DAC input, this function should not be used when the boosted DAC data is expected to be greater than 0dBFS.

REGISTER ADDRESS	BIT	LABEL	DEFAULT	DESCRIPTION
R5 (05h)	11:10	DAC_BOOST [1:0]	00b	DAC Input Volume Boost 00 = 0dB 01 = +6dB (Input data must not exceed -6dBFS) 10 = +12dB (Input data must not exceed -12dBFS) 11 = +18dB (Input data must not exceed -18dBFS)

Table 21 DAC Interface Volume Boost

DIGITAL SIDETONE

A digital sidetone is available when ADCs and DACs are operating at the same sample rate. Digital data from either left or right ADC can be mixed with the audio interface data on the left and right DAC channels. Sidetone data is taken from the ADC high pass filter output, to reduce low frequency noise in the sidetone (e.g. wind noise or mechanical vibration).

The digital sidetone will not function when ADCs and DACs are operating at different sample rates.

When using the digital sidetone, it is recommended that the ADCs are enabled before un-muting the DACs to prevent pop noise. The DAC volumes and sidetone volumes should be set to an appropriate level to avoid clipping at the DAC input.

The digital sidetone is controlled as shown in Table 22.

REGISTER ADDRESS	BIT	LABEL	DEFAULT	DESCRIPTION
R13 (0Dh)	12:9	ADCL_DAC_SVOL [3:0]	0000b	Left Digital Sidetone Volume (See Table 23 for volume range)
	8:5	ADCR_DAC_SVOL [3:0]	0000b	Right Digital Sidetone Volume (See Table 23 for volume range)
	3:2	ADC_TO_DACL [1:0]	00b	Left DAC Digital Sidetone Source 00 = No sidetone 01 = Left ADC 10 = Right ADC 11 = Reserved
	1:0	ADC_TO_DACR [1:0]	00b	Right DAC Digital Sidetone Source 00 = No sidetone 01 = Left ADC 10 = Right ADC 11 = Reserved

Table 22 Digital Sidetone Control

ADCL_DAC_SVOL or ADCR_DAC_SVOL	SIDETONE VOLUME
0000	-36
0001	-33
0010	-30
0011	-27
0100	-24
0101	-21
0110	-18
0111	-15
1000	-12
1001	-9
1010	-6
1011	-3
1100	0
1101	0
1110	0
1111	0

Table 23 Digital Sidetone Volume

DIGITAL TO ANALOGUE CONVERTER (DAC)

The WM8991 DACs receive digital input data from the DACDAT pin and via the digital sidetone path. The digital audio data is converted to oversampled bit streams in the on-chip, true 24-bit digital interpolation filters. The bitstream data enters two multi-bit, sigma-delta DACs, which convert them to high quality analogue audio signals. The multi-bit DAC architecture reduces high frequency noise and sensitivity to clock jitter. It also uses a Dynamic Element Matching technique for high linearity and low distortion.

The analogue outputs from the DACs can then be mixed with other analogue inputs using the output mixers LOMIX, ROMIX and the speaker output mixer SPKMIX.

The DACs are enabled by the DACL_ENA and DACR_ENA register bits.

REGISTER ADDRESS	BIT	LABEL	DEFAULT	DESCRIPTION
R3 (03h)	1	DACL_ENA (rw)	0b	Left DAC Enable 0 = DAC disabled 1 = DAC enabled
	0	DACR_ENA (rw)	0b	Right DAC Enable 0 = DAC disabled 1 = DAC enabled

Table 24 DAC Enable Control

DAC DIGITAL VOLUME CONTROL

The output level of each DAC can be controlled digitally over a range from -71.625dB to 0dB in 0.375dB steps. The level of attenuation for an eight-bit code X is given by:

$$0.375 \times (X-192) \text{ dB for } 1 \leq X \leq 192; \quad \text{MUTE for } X = 0 \quad 0\text{dB for } 192 \leq X \leq 255$$

The DAC_VU bit controls the loading of digital volume control data. When DAC_VU is set to 0, the DACL_VOL or DACR_VOL control data will be loaded into the respective control register, but will not actually change the digital gain setting. Both left and right gain settings are updated when a 1 is written to DAC_VU. This makes it possible to update the gain of both channels simultaneously.

REGISTER ADDRESS	BIT	LABEL	DEFAULT	DESCRIPTION
R11 (0Bh)	8	DAC_VU	N/A	DAC Volume Update Writing a 1 to this bit will cause left and right DAC volume to be updated simultaneously
	7:0	DACL_VOL [7:0]	1100_0000b (0dB)	Left DAC Digital Volume (See Table 26 for volume range)
R12 (0Ch)	8	DAC_VU	N/A	DAC Volume Update Writing a 1 to this bit will cause left and right DAC volume to be updated simultaneously
	7:0	DACR_VOL [7:0]	1100_0000b (0dB)	Right DAC Digital Volume (See Table 26 for volume range)

Table 25 DAC Digital Volume Control

DACL_VOL or DACR_VOL		Volume (dB)	DACL_VOL or DACR_VOL		Volume (dB)	DACL_VOL or DACR_VOL		Volume (dB)	DACL_VOL or DACR_VOL		Volume (dB)
0h		MUTE	40h		-48.000	80h		-24.000	C0h		0.000
1h		-71.625	41h		-47.625	81h		-23.625	C1h		0.000
2h		-71.250	42h		-47.250	82h		-23.250	C2h		0.000
3h		-70.875	43h		-46.875	83h		-22.875	C3h		0.000
4h		-70.500	44h		-46.500	84h		-22.500	C4h		0.000
5h		-70.125	45h		-46.125	85h		-22.125	C5h		0.000
6h		-69.750	46h		-45.750	86h		-21.750	C6h		0.000
7h		-69.375	47h		-45.375	87h		-21.375	C7h		0.000
8h		-69.000	48h		-45.000	88h		-21.000	C8h		0.000
9h		-68.625	49h		-44.625	89h		-20.625	C9h		0.000
Ah		-68.250	4Ah		-44.250	8Ah		-20.250	CAh		0.000
Bh		-67.875	4Bh		-43.875	8Bh		-19.875	CBh		0.000
Ch		-67.500	4Ch		-43.500	8Ch		-19.500	CCh		0.000
Dh		-67.125	4Dh		-43.125	8Dh		-19.125	CDh		0.000
Eh		-66.750	4Eh		-42.750	8Eh		-18.750	CEh		0.000
Fh		-66.375	4Fh		-42.375	8Fh		-18.375	CFh		0.000
10h		-66.000	50h		-42.000	90h		-18.000	D0h		0.000
11h		-65.625	51h		-41.625	91h		-17.625	D1h		0.000
12h		-65.250	52h		-41.250	92h		-17.250	D2h		0.000
13h		-64.875	53h		-40.875	93h		-16.875	D3h		0.000
14h		-64.500	54h		-40.500	94h		-16.500	D4h		0.000
15h		-64.125	55h		-40.125	95h		-16.125	D5h		0.000
16h		-63.750	56h		-39.750	96h		-15.750	D6h		0.000
17h		-63.375	57h		-39.375	97h		-15.375	D7h		0.000
18h		-63.000	58h		-39.000	98h		-15.000	D8h		0.000
19h		-62.625	59h		-38.625	99h		-14.625	D9h		0.000
1Ah		-62.250	5Ah		-38.250	9Ah		-14.250	DAh		0.000
1Bh		-61.875	5Bh		-37.875	9Bh		-13.875	DBh		0.000
1Ch		-61.500	5Ch		-37.500	9Ch		-13.500	DCh		0.000
1Dh		-61.125	5Dh		-37.125	9Dh		-13.125	DDh		0.000
1Eh		-60.750	5Eh		-36.750	9Eh		-12.750	DEh		0.000
1Fh		-60.375	5Fh		-36.375	9Fh		-12.375	DFh		0.000
20h		-60.000	60h		-36.000	A0h		-12.000	E0h		0.000
21h		-59.625	61h		-35.625	A1h		-11.625	E1h		0.000
22h		-59.250	62h		-35.250	A2h		-11.250	E2h		0.000
23h		-58.875	63h		-34.875	A3h		-10.875	E3h		0.000
24h		-58.500	64h		-34.500	A4h		-10.500	E4h		0.000
25h		-58.125	65h		-34.125	A5h		-10.125	E5h		0.000
26h		-57.750	66h		-33.750	A6h		-9.750	E6h		0.000
27h		-57.375	67h		-33.375	A7h		-9.375	E7h		0.000
28h		-57.000	68h		-33.000	A8h		-9.000	E8h		0.000
29h		-56.625	69h		-32.625	A9h		-8.625	E9h		0.000
2Ah		-56.250	6Ah		-32.250	AAh		-8.250	EAh		0.000
2Bh		-55.875	6Bh		-31.875	ABh		-7.875	EBh		0.000
2Ch		-55.500	6Ch		-31.500	ACh		-7.500	ECh		0.000
2Dh		-55.125	6Dh		-31.125	ADh		-7.125	EDh		0.000
2Eh		-54.750	6Eh		-30.750	AEd		-6.750	EEh		0.000
2Fh		-54.375	6Fh		-30.375	AFh		-6.375	EFh		0.000
30h		-54.000	70h		-30.000	B0h		-6.000	F0h		0.000
31h		-53.625	71h		-29.625	B1h		-5.625	F1h		0.000
32h		-53.250	72h		-29.250	B2h		-5.250	F2h		0.000
33h		-52.875	73h		-28.875	B3h		-4.875	F3h		0.000
34h		-52.500	74h		-28.500	B4h		-4.500	F4h		0.000
35h		-52.125	75h		-28.125	B5h		-4.125	F5h		0.000
36h		-51.750	76h		-27.750	B6h		-3.750	F6h		0.000
37h		-51.375	77h		-27.375	B7h		-3.375	F7h		0.000
38h		-51.000	78h		-27.000	B8h		-3.000	F8h		0.000
39h		-50.625	79h		-26.625	B9h		-2.625	F9h		0.000
3Ah		-50.250	7Ah		-26.250	BAh		-2.250	FAh		0.000
3Bh		-49.875	7Bh		-25.875	BBh		-1.875	FBh		0.000
3Ch		-49.500	7Ch		-25.500	BCh		-1.500	FCh		0.000
3Dh		-49.125	7Dh		-25.125	BDh		-1.125	FDh		0.000
3Eh		-48.750	7Eh		-24.750	BEh		-0.750	FEh		0.000
3Fh		-48.375	7Fh		-24.375	BFh		-0.375	FFh		0.000

Table 26 DAC Digital Volume Range

DAC SOFT MUTE AND SOFT UN-MUTE

The WM8991 has a soft mute function which, when enabled, gradually attenuates the volume of the DAC output. When soft mute is disabled, the gain will either gradually ramp back up to the digital gain setting, or return instantly to the digital gain setting, depending on the DAC_MUTEMODE register bit.

The DAC is soft-muted by default (DAC_MUTE = 1). To play back an audio signal, this function must first be disabled by setting DAC_MUTE to 0.

Soft Mute Mode would typically be enabled (DAC_MUTEMODE = 1) when using DAC_MUTE during playback of audio data so that when DAC_MUTE is subsequently disabled, the sudden volume increase will not create pop noise by jumping immediately to the previous volume level (e.g. resuming playback after pausing during a track).

Soft Mute Mode would typically be disabled (DAC_MUTEMODE = 0) when un-muting at the start of a music file, in order that the first part of the track is not attenuated (e.g. when starting playback of a new track, or resuming playback after pausing between tracks).

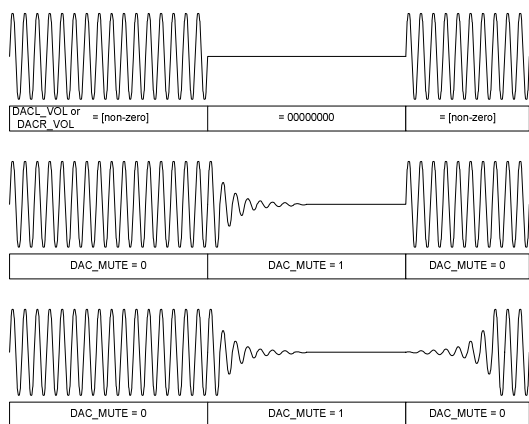

DAC muting and un-muting using volume control bits DACL_VOL and DACR_VOL.

DAC muting and un-muting using soft mute bit DAC_MUTE.

Soft Mute Mode not enabled (DAC_MUTEMODE = 0).

DAC muting and un-muting using soft mute bit DAC_MUTE.

Soft Mute Mode enabled (DAC_MUTEMODE = 1).

Figure 29 DAC Mute Control

The volume ramp rate during soft mute and un-mute is controlled by the DAC_MUTERATE bit. Ramp rates of fs/32 and fs/2 are selectable as shown in Table 27. The ramp rate determines the rate at which the volume will be increased or decreased. The actual ramp time depends on the extent of the difference between the muted and un-muted volume settings.

REGISTER ADDRESS	BIT	LABEL	DEFAULT	DESCRIPTION
R10 (0Ah)	7	DAC_MUTERATE	0b	DAC Soft Mute Ramp Rate 0 = Fast ramp (fs/2, maximum ramp time is 10.7ms at fs=48k) 1 = Slow ramp (fs/32, maximum ramp time is 171ms at fs=48k)
	6	DAC_MUTEMODE	0b	DAC Soft Mute Mode 0 = Disabling soft-mute (DAC_MUTE=0) will cause the DAC volume to change immediately to DACL_VOL and DACR_VOL settings 1 = Disabling soft-mute (DAC_MUTE=0) will cause the DAC volume to ramp up gradually to the DACL_VOL and DACR_VOL settings
	2	DAC_MUTE	1b	DAC Soft Mute Control 0 = DAC Un-mute 1 = DAC Mute

Table 27 DAC Soft-Mute Control

DAC MONO MIX

A DAC digital mono-mix mode can be enabled using the DAC_MONO register bit. This mono mix will be output on the enabled DACs. To prevent clipping, a -6dB attenuation is automatically applied to the mono mix.

REGISTER ADDRESS	BIT	LABEL	DEFAULT	DESCRIPTION
R10 (0Ah)	9	DAC_MONO	0b	DAC Mono Mix 0 = Stereo 1 = Mono (Mono mix output on enabled DACs)

Table 28 DAC Mono Mix

DAC DE-EMPHASIS

Digital de-emphasis can be applied to the DAC playback data (e.g. when the data comes from a CD with pre-emphasis used in the recording). De-emphasis filtering is available for sample rates of 48kHz, 44.1kHz and 32kHz. See "Digital Filter Characteristics" section for details of de-emphasis filter characteristics.

REGISTER ADDRESS	BIT	LABEL	DEFAULT	DESCRIPTION
R10 (0Ah) ADC and DAC Control (1)	5:4	DEEMP [1:0]	00b	DAC De-Emphasis Control 00 = No de-emphasis 01 = 32kHz sample rate 10 = 44.1kHz sample rate 11 = 48kHz sample rate

Table 29 DAC De-Emphasis Control

DAC SLOPING STOPBAND FILTER

Two DAC filter types are available, selected by the register bit DAC_SB_FILTER. When operating at lower sample rates (e.g. during voice communication) it is recommended that the sloping stopband filter type is selected (DAC_SB_FILTER=1) to reduce out-of-band noise which can be audible at low DAC sample rates. See "Digital Filter Characteristics" section for details of DAC filter characteristics.

REGISTER ADDRESS	BIT	LABEL	DEFAULT	DESCRIPTION
R10 (0Ah)	8	DAC_SB_FILTER	0b	Selects DAC filter characteristics 0 = Normal mode 1 = Sloping stopband mode

Table 30 DAC Sloping Stopband Filter

OUTPUT SIGNAL PATH

The WM8991 output routing and mixers provide a high degree of flexibility, allowing operation of many simultaneous signal paths through the device to various analogue outputs. The outputs provide many combinations of headphone, loudspeaker and single-ended line drivers. See "Analogue Outputs" for further details of these outputs.

The WM8991 output signal paths and control registers are illustrated in Figure 30.

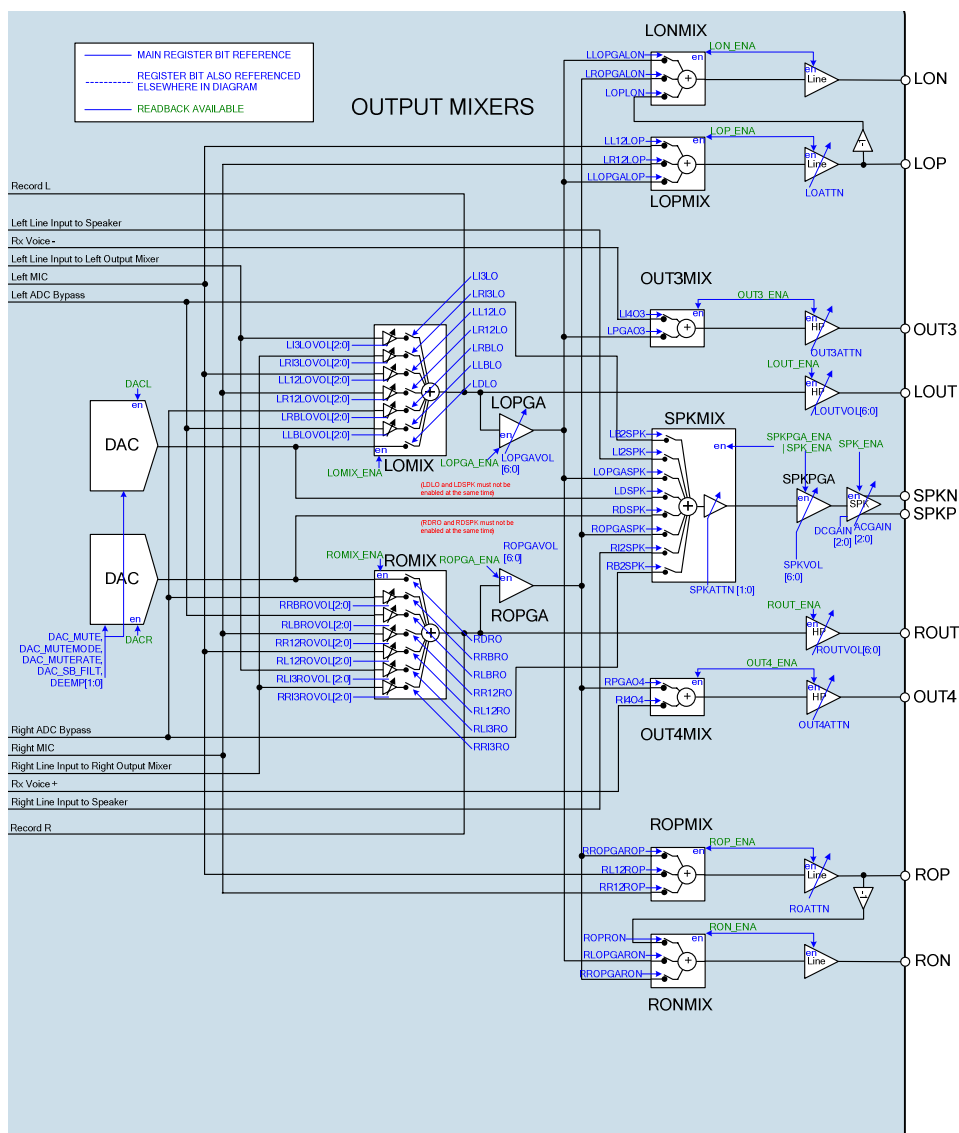

Figure 30 Control Registers for Output Signal Path

OUTPUT SIGNAL PATHS ENABLE

The output mixers and drivers can be independently enabled and disabled as described in Table 31.

Note that the headphone outputs LOUT and ROUT have dedicated volume controls. As a result, the output PGAs LOPGA and ROPGA do not need to be enabled to provide volume control for the LOUT and ROUT outputs.

REGISTER ADDRESS	BIT	LABEL	DEFAULT	DESCRIPTION
R3 (03h)	13	LON_ENA (rw)	0b	LON Line Out and LONMIX Enable 0 = disabled 1 = enabled
	12	LOP_ENA (rw)	0b	LOP Line Out and LOPMIX Enable 0 = disabled 1 = enabled
	11	RON_ENA (rw)	0b	RON Line Out and RONMIX Enable 0 = disabled 1 = enabled
	10	ROP_ENA (rw)	0b	ROP Line Out and ROPMIX Enable 0 = disabled 1 = enabled
	8	SPKPGA_ENA (rw)	0b	SPKMIX Mixer and Speaker PGA Enable 0 = disabled 1 = enabled Note that SPKMIX and SPKPGA are also enabled when SPK_ENA is set.
	7	LOPGA_ENA (rw)	0b	LOPGA Left Volume Control Enable 0 = disabled 1 = enabled
	6	ROPGA_ENA (rw)	0b	ROPGA Right Volume Control Enable 0 = disabled 1 = enabled
	5	LOMIX_ENA (rw)	0b	LOMIX Left Output Mixer Enable 0 = disabled 1 = enabled
	4	ROMIX_ENA (rw)	0b	ROMIX Right Output Mixer Enable 0 = disabled 1 = enabled
R1 (01h)	12	SPK_ENA (rw)	0b	SPKMIX Mixer, Speaker PGA and Speaker Output Enable 0 = disabled 1 = enabled
	11	OUT3_ENA (rw)	0b	OUT3 and OUT3MIX Enable 0 = disabled 1 = enabled
	10	OUT4_ENA (rw)	0b	OUT4 and OUT4MIX Enable 0 = disabled 1 = enabled
	9	LOUT_ENA (rw)	0b	LOUT (Left Headphone Output) Enable 0 = disabled 1 = enabled
	8	ROUT_ENA (rw)	0b	ROUT (Right Headphone Output) Enable 0 = disabled 1 = enabled

Table 31 Output Signal Paths Enable

OUTPUT MIXER CONTROL

The Output Mixer volume controls are described in Table 32 for the Left Channel and Table 33 for the Right Channel. The gain of each of analogue input paths may be controlled independently in the range described in Table 34. The DAC input levels may be controlled by the DAC digital volume control - see "Digital to Analogue Converter (DAC)" for further details of this control.

REGISTER ADDRESS	BIT	LABEL	DEFAULT	DESCRIPTION
R45 (2Dh)	5	LRI3LO	0b	RIN3 to LOMIX Mute 0 = Mute 1 = Un-mute
R45 (2Dh)	4	LLI3LO	0b	LIN3 to LOMIX Mute 0 = Mute 1 = Un-mute
R49 (31h)	8:6	LRI3LOVOL [2:0]	000b	RIN3 to LOMIX Volume (See Table 34 for Volume Range)
R47 (2Fh)	8:6	LLI3LOVOL [2:0]	000b	LIN3 to LOMIX Volume (See Table 34 for Volume Range)
R45 (2Dh)	2	LL12LO	0b	LIN12 PGA Output to LOMIX Mute 0 = Mute 1 = Un-mute
R47 (2Fh)	2:0	LL12LOVOL [2:0]	000b	LIN12 PGA Output to LOMIX Volume (See Table 34 for Volume Range)
R45 (2Dh)	3	LR12LO	0	RIN12 PGA Output to LOMIX Mute 0 = Mute 1 = Un-mute
R47 (2Fh)	5:3	LR12LOVOL [2:0]	000b	RIN12 PGA Output to LOMIX Volume (See Table 34 for Volume Range)
R45 (2Dh)	7	LRBLO	0b	AINRMUX Output (Right ADC bypass) to LOMIX Mute 0 = Mute 1 = Un-mute
R49 (31h)	5:3	LRBLOVOL [2:0]	000b	AINRMUX Output (Right ADC bypass) to LOMIX Volume (See Table 34 for Volume Range)
R45 (2Dh)	6	LLBLO	0b	AINLMUX Output (Left ADC bypass) to LOMIX Mute 0 = Mute 1 = Un-mute
R49 (31h)	2:0	LLBLOVOL [2:0]	000b	AINLMUX Output (Left ADC bypass) to LOMIX Volume (See Table 34 for Volume Range)
R45 (2Dh)	0	LDLO	0b	Left DAC to LOMIX Mute 0 = Mute 1 = Un-mute Note: LDLO must be muted when LDSPK=1

Table 32 Left Output Mixer (LOMIX) Volume Control

REGISTER ADDRESS	BIT	LABEL	DEFAULT	DESCRIPTION
R46 (2Eh)	5	RLI3RO	0b	LIN3 to ROMIX Mute 0 = Mute 1 = Un-mute
R46 (2Eh)	4	RRI3RO	0b	RIN3 to ROMIX Mute 0 = Mute 1 = Un-mute
R50 (32h)	8:6	RLI3ROVOL [2:0]	000b	LIN3 to ROMIX Volume (See Table 34 for Volume Range)
R48 (30h)	8:6	RRI3ROVOL [2:0]	000b	RIN3 to ROMIX Volume (See Table 34 for Volume Range)
R46 (2Eh)	3	RL12RO	0b	LIN12 PGA Output to ROMIX Mute 0 = Mute 1 = Un-mute
R48 (30h)	5:3	RL12ROVOL [2:0]	000b	LIN12 PGA Output to ROMIX Volume (See Table 34 for Volume Range)
R46 (2Eh)	2	RR12RO	0b	RIN12 PGA Output to ROMIX Mute 0 = Mute 1 = Un-mute
R48 (30h)	2:0	RR12ROVOL [2:0]	000b	RIN12 PGA Output to ROMIX Volume (See Table 34 for Volume Range)
R46 (2Eh)	7	RLBRO	0b	AINLMUX Output (Left ADC bypass) to ROMIX Mute 0 = Mute 1 = Un-mute
R50 (32h)	5:3	RLBROVOL [2:0]	000b	AINLMUX Output (Left ADC bypass) to ROMIX Volume (See Table 34 for Volume Range)
R46 (2Eh)	6	RRBRO	0b	AINRMUX Output (Right ADC bypass) to ROMIX 0 = Mute 1 = Un-mute
R50 (32h)	2:0	RRBROVOL [2:0]	000b	AINRMUX Output (Right ADC bypass) to ROMIX Volume (See Table 34 for Volume Range)
R46 (2Eh)	0	RDRO	0b	Right DAC to ROMIX Mute 0 = Mute 1 = Un-mute Note: RDRO must be muted when RDSPK=1

Table 33 Right Output Mixer (ROMIX) Volume Control

VOLUME SETTING	VOLUME (dB)
000	0
001	-3
010	-6
011	-9
100	-12
101	-15
110	-18
111	-21

Table 34 LOMIX and ROMIX Volume Range

OUTPUT SIGNAL PATH VOLUME CONTROL

The output drivers LOPGA, ROPGA, LOOUT and ROOUT can be independently controlled as shown in Table 35 and Table 36.

To minimise pop noise it is recommended that only the LOPGAVOL, ROPGAVOL, LOOUTVOL and ROOUTVOL are modified while the output signal path is active. Other gain controls are provided in the output signal path to provide appropriate relative scaling of signals from different sources, and to prevent clipping when multiple signals are mixed. To prevent pop noise, only the gain controls noted above should be modified while playback is active.

To prevent "zipper noise", a zero-cross function is provided on these output paths, so that when enabled, volume updates will not take place until a zero-crossing is detected. In the event of a long period without zero-crossings, a timeout function is available. When this function is enabled (using the TOCLK_ENA register bit), the volume will update after the timeout period if no earlier zero-cross has occurred. The timeout period is set by TOCLK_RATE. See "Clocking and Sample Rates" for more information on these fields.

The OPVU bit controls the loading of the output driver volume data. When OPVU is set to 0, the volume control data will be loaded into the respective control register, but will not actually change the gain setting. The LOPGA, ROPGA, LOOUT and ROOUT volume settings are all updated when a 1 is written to OPVU. This makes it possible to update the gain of all output paths simultaneously.

Note that the headphone outputs LOOUT and ROOUT have dedicated volume controls. As a result, the output PGAs LOPGA and ROPGA do not need to be enabled to provide volume control for the LOOUT and ROOUT outputs.

REGISTER ADDRESS	BIT	LABEL	DEFAULT	DESCRIPTION
R32 (20h)	8	OPVU[2]	N/A	Output PGA Volume Update Writing a 1 to this bit will update LOPGA, ROPGA, LOUVOL and ROUTVOL volumes simultaneously.
	7	LOPGAZC	0b	LOPGA Zero Cross Enable 0 = Zero cross disabled 1 = Zero cross enabled
	6:0	LOPGAVOL [6:0]	79h (0dB)	LOPGA Volume (See Table 36 for output PGA volume control range)
R33 (21h)	8	OPVU[3]	N/A	Output PGA Volume Update Writing a 1 to this bit will update LOPGA, ROPGA, LOUVOL and ROUTVOL volumes simultaneously.
	7	ROPGAZC	0b	ROPGA Zero Cross Enable 0 = Zero cross disabled 1 = Zero cross enabled
	6:0	ROPGAVOL [6:0]	79h (0dB)	ROPGA Volume (See Table 36 for output PGA volume control range)
R28 (1Ch)	8	OPVU[0]	N/A	Output PGA Volume Update Writing a 1 to this bit will update LOPGA, ROPGA, LOUVOL and ROUTVOL volumes simultaneously.
	7	LOZC	0b	LOUT (Left Headphone Output) Zero Cross Enable 0 = Zero cross disabled 1 = Zero cross enabled
	6:0	LOUVOL [6:0]	00h (mute)	LOUT (Left Headphone Output) Volume (See Table 36 for output PGA volume control range)
R29 (1Dh)	8	OPVU[1]	N/A	Output PGA Volume Update Writing a 1 to this bit will update LOPGA, ROPGA, LOUVOL and ROUTVOL volumes simultaneously.
	7	ROZC	0b	ROUT (Right Headphone Output) Zero Cross Enable 0 = Zero cross disabled 1 = Zero cross enabled
	6:0	ROUTVOL [6:0]	00h (mute)	ROUT (Right Headphone Output) Volume (See Table 36 for output PGA volume control range)

Table 35 LOPGA, ROPGA, LOUVOL and ROUT Volume Control

LOPGAVOL, ROPGAVOL, LOUTVOL, ROUTVOL or SPKVOL	Volume (dB)	LOPGAVOL, ROPGAVOL, LOUTVOL, ROUTVOL or SPKVOL	Volume (dB)
0h	MUTE	40h	-57
1h	MUTE	41h	-56
2h	MUTE	42h	-55
3h	MUTE	43h	-54
4h	MUTE	44h	-53
5h	MUTE	45h	-52
6h	MUTE	46h	-51
7h	MUTE	47h	-50
8h	MUTE	48h	-49
9h	MUTE	49h	-48
Ah	MUTE	4Ah	-47
Bh	MUTE	4Bh	-46
Ch	MUTE	4Ch	-45
Dh	MUTE	4Dh	-44
Eh	MUTE	4Eh	-43
Fh	MUTE	4Fh	-42
10h	MUTE	50h	-41
11h	MUTE	51h	-40
12h	MUTE	52h	-39
13h	MUTE	53h	-38
14h	MUTE	54h	-37
15h	MUTE	55h	-36
16h	MUTE	56h	-35
17h	MUTE	57h	-34
18h	MUTE	58h	-33
19h	MUTE	59h	-32
1Ah	MUTE	5Ah	-31
1Bh	MUTE	5Bh	-30
1Ch	MUTE	5Ch	-29
1Dh	MUTE	5Dh	-28
1Eh	MUTE	5Eh	-27
1Fh	MUTE	5Fh	-26
20h	MUTE	60h	-25
21h	MUTE	61h	-24
22h	MUTE	62h	-23
23h	MUTE	63h	-22
24h	MUTE	64h	-21
25h	MUTE	65h	-20
26h	MUTE	66h	-19
27h	MUTE	67h	-18
28h	MUTE	68h	-17
29h	MUTE	69h	-16
2Ah	MUTE	6Ah	-15
2Bh	MUTE	6Bh	-14
2Ch	MUTE	6Ch	-13
2Dh	MUTE	6Dh	-12
2Eh	MUTE	6Eh	-11
2Fh	MUTE	6Fh	-10
30h	-73	70h	-9
31h	-72	71h	-8
32h	-71	72h	-7
33h	-70	73h	-6
34h	-69	74h	-5
35h	-68	75h	-4
36h	-67	76h	-3
37h	-66	77h	-2
38h	-65	78h	-1
39h	-64	79h	0
3Ah	-63	7Ah	1
3Bh	-62	7Bh	2
3Ch	-61	7Ch	3
3Dh	-60	7Dh	4
3Eh	-59	7Eh	5
3Fh	-58	7Fh	6

Table 36 LOPGA, ROPGA, LOU, ROUT and SPKVOL Volume Range

The speaker mixer SPKMIX, the speaker PGA SPKPGA and the outputs SPKN and SPKP are controlled as described in Table 37. Care should be taken to avoid clipping when enabling more than one path to the speaker mixer.

Register bits SPKATTN control the speaker output attenuation and can be used to avoid clipping when more than one full scale signal is input to the mixer. Fine adjustment of the speaker output can be made using the SPKVOL register field.

To prevent "zipper noise" when adjusting the SPKVOL, a zero-cross function is provided so that, when enabled, volume updates will not take place until a zero-crossing is detected. In the event of a long period without zero-crossings, a timeout function is available. When this function is enabled (using the TOCLK_ENA register bit), the volume will update after the timeout period if no earlier zero-cross has occurred. The timeout period is set by TOCLK_RATE. See "Clocking and Sample Rates" for more information on these fields.

REGISTER ADDRESS	BIT	LABEL	DEFAULT	DESCRIPTION
R54 (36h)	7	LB2SPK	0b	AINLMUX Output to SPKMIX 0 = Mute 1 = Un-mute
	6	RB2SPK	0b	AINRMUX Output to SPKMIX 0 = Mute 1 = Un-mute
	5	LI2SPK	0b	LIN2 to SPKMIX 0 = Mute 1 = Un-mute
	4	RI2SPK	0b	RIN2 to SPKMIX 0 = Mute 1 = Un-mute
	3	LOPGASPK	0b	LOPGA to SPKMIX 0 = Mute 1 = Un-mute
	2	ROPGASPK	0b	ROPGA to SPKMIX 0 = Mute 1 = Un-mute
	1	LDSPK	0b	Left DAC to SPKMIX 0 = Mute 1 = Un-mute Note: LDSPK must be muted when LDLO=1
	0	RDSPK	0b	Right DAC to SPKMIX 0 = Mute 1 = Un-mute Note: RDSPK must be muted when RDRO=1
R34 (22h)	1:0	SPKATTN [1:0]	11b	Speaker Output Attenuation (SPKN and SPKP) 00 = 0dB 01 = -6dB 10 = -12dB 11 = mute
R38 (26h)	7	SPKZC	0b	SPKPGA Zero Cross Enable 0 = Zero cross disabled 1 = Zero cross enabled
	6:0	SPKVOL [6:0]	79h (0dB)	SPKPGA Volume (see Table 36 for SPKPGA volume control range)

Table 37 Speaker Output Volume Control

The output mixers OUT3MIX and OUT4MIX and their outputs OUT3 and OUT4 are controlled as described in Table 38. Care should be taken to avoid clipping when enabling more than one path to OUT3 or OUT4. The OUT3ATTN and OUT4ATTN attenuation controls can be used to prevent clipping when more than one full scale signal is input to the mixers.

REGISTER ADDRESS	BIT	LABEL	DEFAULT	DESCRIPTION
R31 (1Fh)	5	OUT3MUTE	1b	OUT3 Mute 0 = Un-mute 1 = Mute
	4	OUT3ATTN	0b	OUT3 Attenuation 0 = 0dB 1 = -6dB
	1	OUT4MUTE	1b	OUT4 Mute 0 = Un-mute 1 = Mute
	0	OUT4ATTN	0b	OUT4 Attenuation 0 = 0dB 1 = -6dB
R51 (33h)	5	LI4O3	0b	LIN4/RXN Pin to OUT3MIX 0 = Mute 1 = Un-mute
	4	LPGA03	0b	LOPGA to OUT3MIX 0 = Mute 1 = Un-mute
	1	RI4O4	0b	RIN4/RXP Pin to OUT4MIX 0 = Mute 1 = Un-mute
	0	RPGA04	0b	ROPGA to OUT4MIX 0 = Mute 1 = Un-mute

Table 38 OUT3 and OUT4 Volume Control

The output mixers LOPMIX and LONMIX and their outputs LOP and LON are controlled as described in Table 39. Care should be taken to avoid clipping when enabling more than one path to LOP or LON. The LOATTN attenuation control can be used to prevent clipping when more than one full scale signal is input to the LOP mixer.

REGISTER ADDRESS	BIT	LABEL	DEFAULT	DESCRIPTION
R30 (1Eh)	6	LONMUTE	1b	LON Line Output Mute 0 = Un-mute 1 = Mute
	5	LOPMUTE	1b	LOP Line Output Mute 0 = Un-mute 1 = Mute
	4	LOATTN	0b	LOP Attenuation 0 = 0dB 1 = -6dB
R52 (34h)	6	LLOPGALON	0b	LOPGA to LONMIX 0 = Mute 1 = Un-mute
	5	LROPGALON	0b	ROPGA to LONMIX 0 = Mute 1 = Un-mute
	4	LOPLON	0b	Inverted LOP Output to LONMIX 0 = Mute 1 = Un-mute
	2	LR12LOP	0b	RIN12 PGA Output to LOPMIX 0 = Mute 1 = Un-mute
	1	LL12LOP	0b	LIN12 PGA Output to LOPMIX 0 = Mute 1 = Un-mute
	0	LLOPGALOP	0b	LOPGA to LOPMIX 0 = Mute 1 = Un-mute

Table 39 LOP and LON Volume Control

The output mixers ROPMIX and RONMIX and their outputs ROP and RON are controlled as described in Table 40. Care should be taken to avoid clipping when enabling more than one path to ROP or RON. The ROATTN attenuation control can be used to prevent clipping when more than one full scale signal is input to the ROP mixer.

REGISTER ADDRESS	BIT	LABEL	DEFAULT	DESCRIPTION
R30 (1Eh)	2	RONMUTE	1b	RON Line Output Mute 0 = Un-mute 1 = Mute
	1	ROPMUTE	1b	ROP Line Output Mute 0 = Un-mute 1 = Mute
	0	ROATTN	0b	ROP Attenuation 0 = 0dB 1 = -6dB
R53 (35h)	6	RROPGARON	0b	ROPGA to RONMIX 0 = Mute 1 = Un-mute
	5	RLOPGARON	0b	LOPGA to RONMIX 0 = Mute 1 = Un-mute
	4	ROPRON	0b	Inverted ROP Output to RONMIX 0 = Mute 1 = Un-mute
	2	RL12ROP	0b	LIN12 PGA Output to ROPMIX 0 = Mute 1 = Un-mute
	1	RR12ROP	0b	RIN12 PGA Output to ROPMIX 0 = Mute 1 = Un-mute
	0	RROPGAROP	0b	ROPGA to ROPMIX 0 = Mute 1 = Un-mute

Table 40 ROP and RON Volume Control

ANALOGUE OUTPUTS

The speaker, headphone and line outputs are highly configurable and may be used in many different ways.

SPEAKER OUTPUT CONFIGURATIONS

The speaker outputs SPKP and SPKN are driven by the speaker mixer SPKMIX, and speaker volume control SPKPGA, which can output a mix that is any combination of the following signals:

- Left DAC and Right DAC outputs
- LOMIX and ROMIX outputs via volume controls LOPGA and ROPGA
- Line inputs LIN2 and RIN2
- Output from left and right input mixers (AINLMUX & AINRMUX)

The speaker mixer is controlled as described under “Output Signal Path”. The speaker mixer output can be attenuated to avoid clipping when mixing multiple signal inputs. Fine adjustment of the speaker output can be made by the speaker volume control SPKPGA.

The speaker outputs SPKP and SPKN operate in a BTL configuration in Class AB and Class D amplifier modes. The mode is selected by register bit CDMODE. The outputs are capable of driving 1W into an 8Ω BTL load (or 500mW in class AB mode for thermal reasons) at room temperature. For performance at higher temperatures, see Figure 2 in the “Recommended Operating Conditions” section. Ultra-low leakage and high PSRR allow the speaker supply SPKVDD to be directly connected to a lithium battery.

Six levels of AC and DC signal boost are provided in order to deliver maximum output power for many commonly-used SPKVDD/AVDD combinations. These boost options are available in both Class AB and Class D modes. The AC and DC gain levels from 1.0x to 1.8x are selected using register bits ACGAIN and DCGAIN. To prevent pop noise, DCGAIN and ACGAIN should not be modified while the speaker outputs are enabled.

Note that an appropriate SPKVDD supply voltage must be provided to prevent waveform clipping when speaker boost is used.

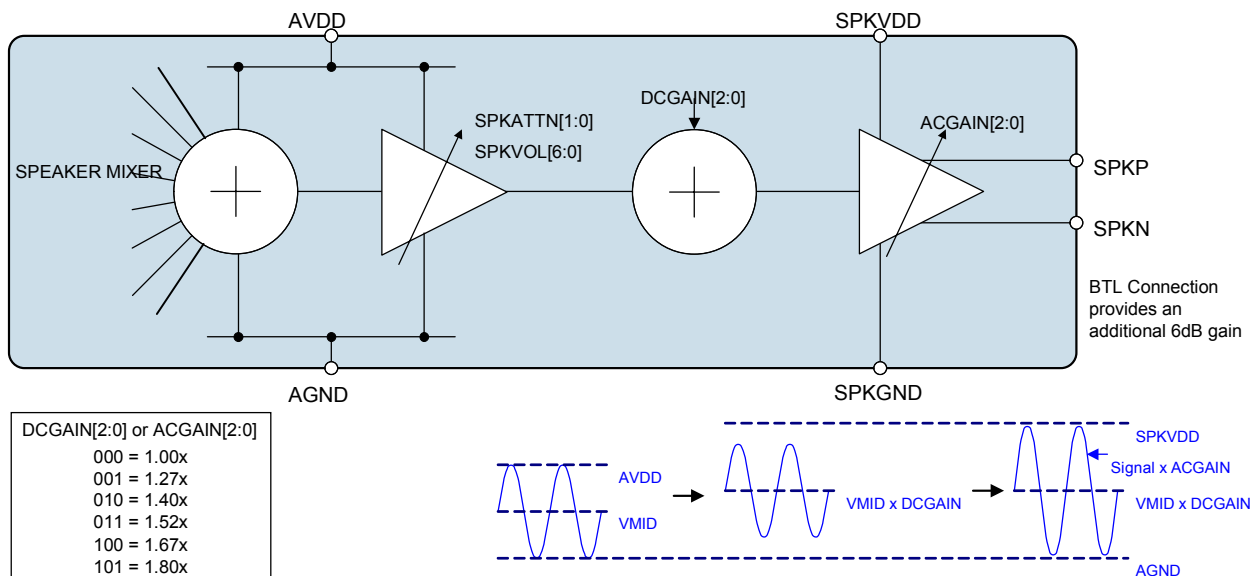

Figure 31 Speaker Boost Operation

REGISTER ADDRESS	BIT	LABEL	DEFAULT	DESCRIPTION
R35 (23h)	8	CDMODE	0b	Speaker Class D Mode Enable 0 = Class D mode 1 = Class AB mode
R37 (25h)	5:3	DCGAIN [2:0]	000b (1.0x)	DC Speaker Boost 000 = 1.00x boost (+0dB) 001 = 1.27x boost (+2.1dB) 010 = 1.40x boost (+2.9dB) 011 = 1.52x boost (+3.6dB) 100 = 1.67x boost (+4.5dB) 101 = 1.80x boost (+5.1dB) 110 to 111 = Reserved
	2:0	ACGAIN [2:0]	000b (1.0x)	AC Speaker Boost 000 = 1.00x boost (+0dB) 001 = 1.27x boost (+2.1dB) 010 = 1.40x boost (+2.9dB) 011 = 1.52x boost (+3.6dB) 100 = 1.67x boost (+4.5dB) 101 = 1.80x boost (+5.1dB) 110 to 111 = Reserved

Table 41 Speaker Boost Control

HEADPHONE OUTPUT CONFIGURATIONS

The headphone outputs LOUT, ROUT, OUT3 and OUT4 are each driven by different output mixers as described below.

The LOUT and ROUT pins output the LOMIX and ROMIX outputs respectively.

The output mixer OUT3MIX produces an output OUT3 that is a combination of:

- LIN4/RXN
- LOMIX output via volume control LOPGA

The output mixer OUT4MIX produces an output OUT4 that is a combination of:

- RIN4/RXP
- ROMIX output via volume control ROPGA

Full volume control is available on LOUT and ROUT. 0dB and -6dB attenuation is available on OUT3 and OUT4, with full volume control available using LOPGA and ROPGA for the LOMIX and ROMIX signals.

The outputs LOUT, ROUT, OUT3 and OUT4 are capable of driving 40mW into 16Ω loads such as stereo headsets, headphones, and/or a handset ear speaker. AC-coupled, capless mode and fully differential headphone drive modes are available.

AC-coupled output is possible on each of LOUT, ROUT, OUT3 and OUT4 simultaneously.

Capless headphone output is possible on LOUT and ROUT by using either OUT3 or OUT4 as the common return path. (This is achieved by muting OUT3 or OUT4 as required.)

If RXP and RXN are a mono differential input (e.g. a connection to an external voice CODEC), then OUT3 and OUT4 may be used as a differential output capable of driving a handset ear speaker. The signal paths from RXP to OUT4 and from RXN to OUT3 are direct, and do not pass through any additional amplifiers. This reduces standby and active power consumption and improves signal quality.

When driving a handset ear speaker using OUT3 and OUT4 other than from RXP/RXN, the required phase difference can be provided by inverting one of the DAC outputs or alternatively by mixing Left and Right channels together using either LOMIX or ROMIX and muting the opposite channel.

Note that a differential output will provide an additional 6dB gain at the output pins. Register bits OUT3ATTN and OUT4ATTN can be used to compensate for this gain if required.

Fully differential headphone drive is possible between LOUT and OUT3 and between ROUT and OUT4. Routing LOPGA to OUT3 and ROPGA to OUT4 results in a phase inversion at LOUT with respect to OUT3 and at ROUT with respect to OUT4. This allows fully differential headset drive, with greatly improved crosstalk performance, improved bass response, increased noise immunity and removing the need for large and expensive DC-blocking capacitors.

To ensure fully balanced differential operation, LOUT and OUT3 must be set to the same gain as each other, and ROUT and OUT4 must be set to the same gain as each other. This is best achieved by setting OUT3ATTN and OUT4ATTN to 0dB, whilst setting volume controls LOPGAVOL and LOUTVOL at matching levels and setting volume controls ROPGAVOL and ROUTVOL at matching levels.

Some example headphone output configurations are shown below.

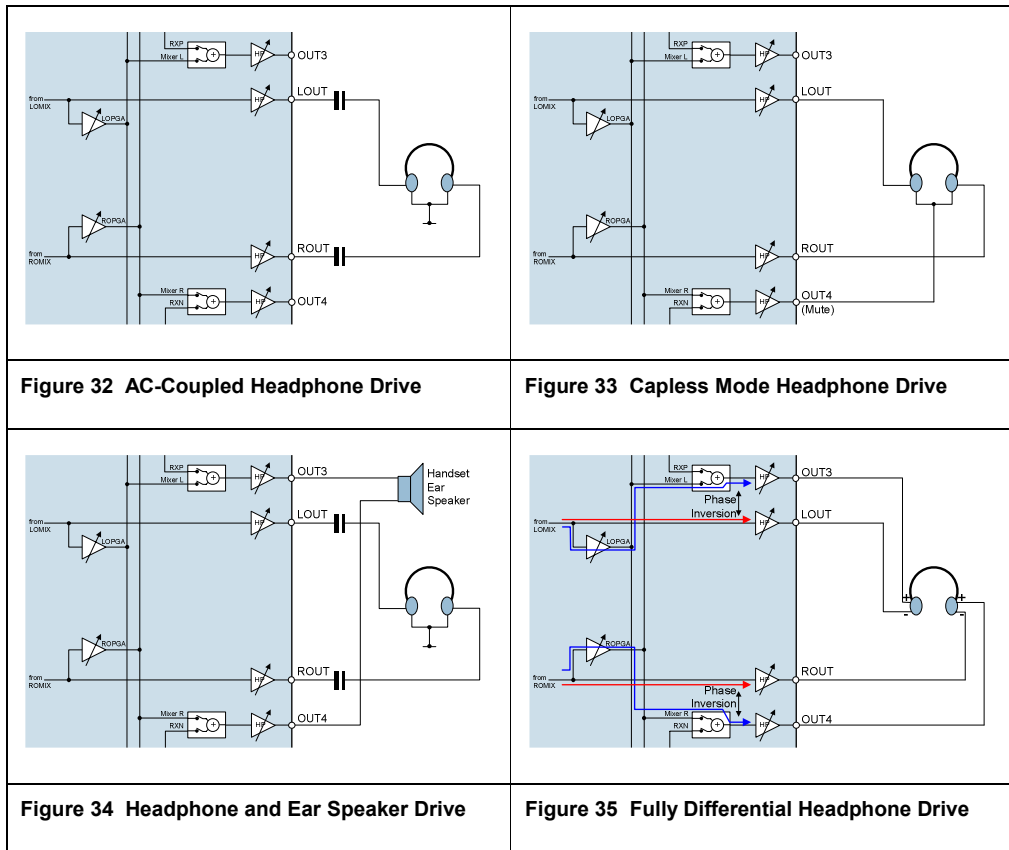

LINE OUTPUT CONFIGURATIONS

The line outputs LON, LOP, RON and ROP are each driven by different output mixers as described below.

The LOP and ROP pins output a mix of LIN12 input PGA, RIN12 input PGA and either LOMIX or ROMIX outputs.

The LON output is a mix of ROMIX, LOMIX and a phase-inverted copy of LOP.

The RON output is a mix of LOMIX, ROMIX and a phase-inverted copy of ROP.

Volume control of LOMIX and ROMIX is available in all cases above via LOPGA and ROPGA. An additional -6dB attenuation option is provided on LOP and ROP outputs.

The outputs LON, LOP, RON and ROP are capable of driving line loads only. Single ended output is possible on all these output simultaneously. Differential output is also possible between LOP and LON and between ROP and RON.

Typical applications for the line outputs (single-ended or differential) are:

- Handset or headset microphone output to external voice CODEC
- Stereo line output
- Output to external speaker driver(s) to support stereo loudspeakers

Some example line output configurations are shown below.

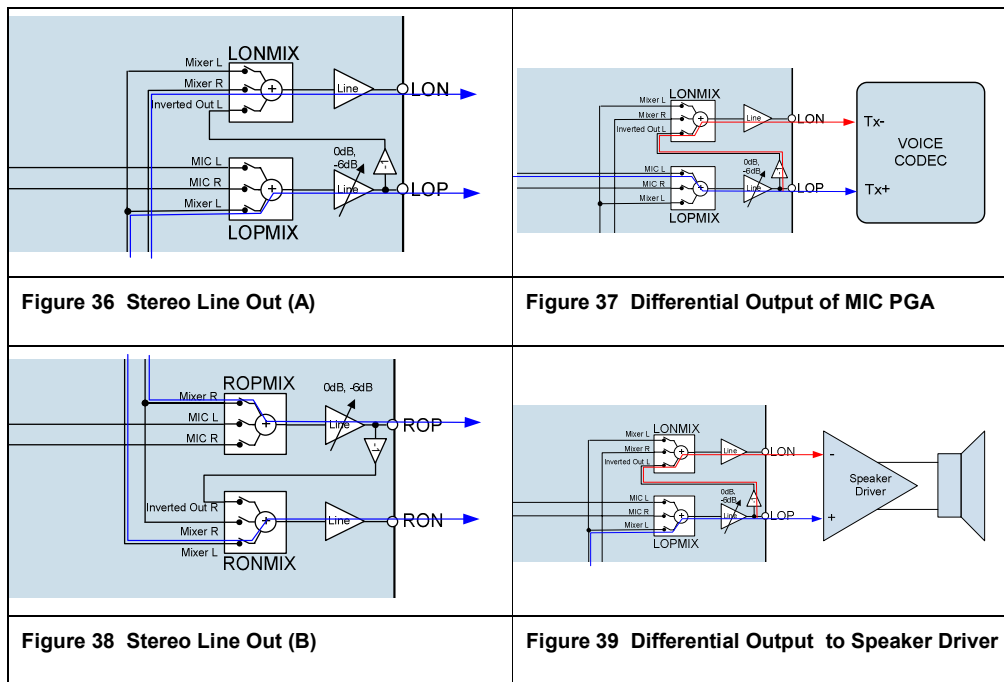

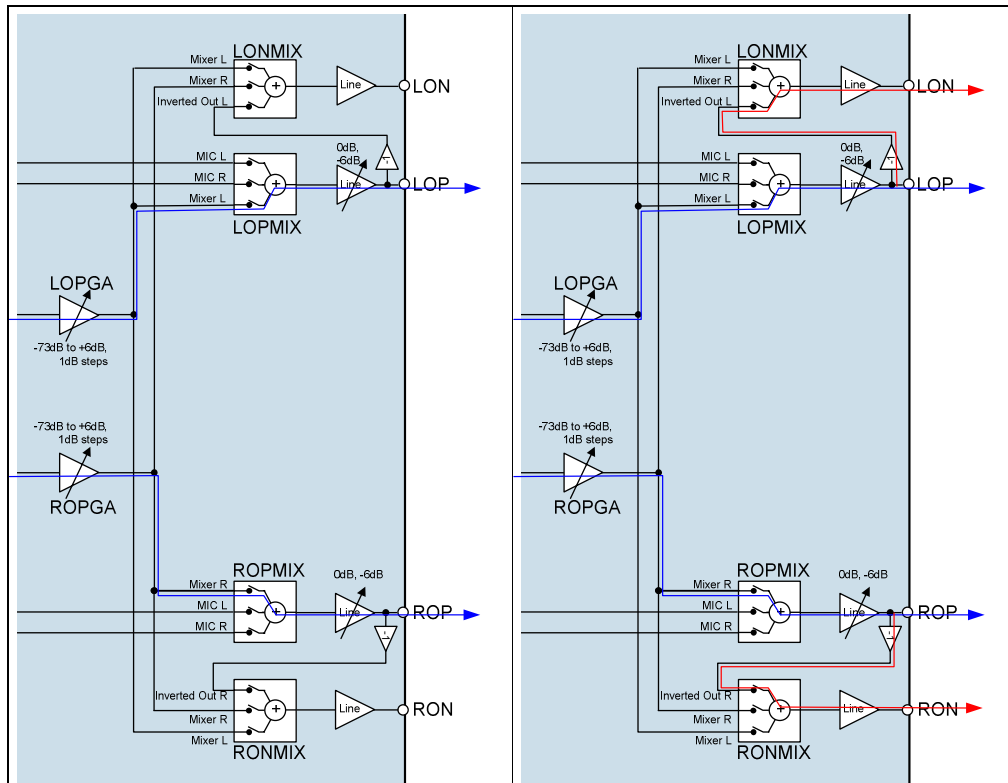

Figure 40 Stereo Line Out (C)

Figure 41 Stereo Differential Line Out

DISABLED OUTPUTS

Whenever an analogue output is disabled, it can be connected to VREF through a resistor; this feature is enabled by setting the BUFIOEN bit – see “Pop Suppression Control”. This helps to prevent pop noise when the output is re-enabled. The resistance between VREF and each output can be controlled using register bit VROI. By default, a high resistance is used - 20kΩ for Headphone outputs (LOUT, ROUT, OUT3 and OUT4) and 10kΩ for Line outputs (LON, LOP, RON and ROP). If a low impedance is desired for disabled outputs, VROI can then be set to 1, decreasing the resistance to about 500Ω in all cases.

Note that a disabled output may be used as a common ground connection for a capless headphone output as described earlier.

REGISTER ADDRESS	BIT	LABEL	DEFAULT	DESCRIPTION
R55 (37h) Additional Control	0	VROI	0	VREF to Analogue Output Resistance (Disabled Outputs) 0 = 20kΩ (Headphone) or 10kΩ (Line Out) from buffered VMID to output 1 = 500Ω from buffered VMID to output

Table 42 Disabled Outputs to VREF Resistance

THERMAL SHUTDOWN

The speaker and headphone outputs can drive very large currents. To protect the WM8991 from overheating a thermal shutdown circuit is included. If the device temperature reaches approximately 150°C and the thermal shutdown circuit is enabled (TSHUT_ENA = 1; TSHUT_OPDIS = 1) the speaker and headphone amplifiers (LOUT, ROUT, SPKP, SPKN, OUT3 and OUT4) will be disabled.

TSHUT_ENA must be set to 1 to enable the temperature sensor when using the TSHUT_OPDIS thermal shutdown function. The output of the temperature sensor can also be output to the GPIO pins.

REGISTER ADDRESS	BIT	LABEL	DEFAULT	DESCRIPTION
R2 (02h)	14	TSHUT_ENA (rw)	1b	Thermal Sensor Enable 0 = Thermal sensor disabled 1 = Thermal sensor enabled
	13	TSHUT_OPDIS (rw)	1b	Thermal Shutdown Enable (Requires thermal sensor to be enabled) 0 = Thermal shutdown disabled 1 = Thermal shutdown enabled

Table 43 Thermal Shutdown

When the speaker driver is operating in class AB mode the internal power dissipation of the WM8991 is likely to be significantly higher than when operating in class D mode.

Note: To prevent potential pops and clicks TSHUT_ENA and TSHUT_OPDIS need to be configured while the speaker and headphone outputs are off, i.e. LOUT_ENA, ROUT_ENA, OUT3_ENA, OUT4_ENA and SPK_ENA are 0 (see also Table 79).

GENERAL PURPOSE INPUT/OUTPUT

The WM8991 provides a number of versatile GPIO functions to enable features such as mobile TV support, Wi-Fi voice call recording, button and accessory detection and clock output.

The WM8991 has eight multi-purpose pins for these functions.

- GPIO1 to GPIO6: Dedicated GPIO pins.
- LIN3/GPI7 and RIN3/GPI8: Analogue inputs or button/accessory detect inputs.

The following functions are available on some or all of the GPIO pins.

- Alternative DAC interface (DACDAT, DACLRC, BCLK)
- Button detect (latched with programmable de-bounce)
- MICBIAS / Accessory current or short circuit detect
- Alternative MCLK input
- Clock output
- Inverted ADCLRC output
- Temperature sensor output
- PLL lock output
- Logic '1' and logic '0' output
- Interrupt event output
- Serial data output (register readback)

The functions available on each of the GPIO pins are identified in Table 44.

GPIO Pin Function	GPIO PINS							
	GPIO1	GPIO2	GPIO3	GPIO4	GPIO5	GPIO6	GPI7	GPI8
ADCLRC	Y							
MCLK2		Y						
BCLK2			Y					
DACLRC2				Y				
DACDAT2					Y			
ADCLRCB						Y		
Button/Accessory Detect Input	Y	Y	Y	Y	Y	Y	Y	Y
Clock Output	Y	Y	Y	Y	Y	Y		
Temperature OK	Y	Y	Y	Y	Y	Y		
PLL Lock	Y	Y	Y	Y	Y	Y		
Logic 1 and Logic 0	Y	Y	Y	Y	Y	Y		
Interrupt	Y	Y	Y	Y	Y	Y		
SDOUT (Readback Data)	Y	Y	Y	Y	Y	Y		
Pull-up & Pull-down Available	Y	Y	Y	Y	Y	Y		

Table 44 Functions Available on GPIO Pins

The GPIO pins are configured by a combination of register settings described in Table 45 to Table 48 in the following section. The order of precedence for the control of the GPIO pins is as listed below.

1. Pin pull-up or pull-down (GPIO_n_PU, GPIO_n_PD)
2. Audio Interface and GPIO Tristate (AIF_TRIS)
3. Pin configuration (AIFSEL, MCLK_SRC, ALRCGPIO1, and ALRCBGPIO6)
4. GPIO functionality (GPIO_n_SEL)

GPIO CONTROL REGISTERS

Table 45 shows how the dual-function GPIO pins are configured to operate in their different modes. Note that the order of precedence described earlier applies.

Register field AIF_SEL selects the function of GPIO3, GPIO4 and GPIO5 between Audio Interface 2 and GPIO functions. Register field ALRCGPIO1 enables the GPIO functionality on GPIO1. Register field MCLK_SRC enables the GPIO functionality on GPIO2. Register field ALRCGPIO6 enables the inverted ADCLRC output on GPIO6. Register bit AIF_TRIS, when set, takes precedence over AIF_SEL, ALRCGPIO1, MCLK_SRC and ALRCGPIO6 and tri-states all GPIO pins.

REGISTER ADDRESS	BIT	LABEL	DEFAULT	DESCRIPTION
R7 (07h)	15	MCLK_SRC	0b	MCLK Source Select 0 = MCLK pin 1 = GPIO2/MCLK2 pin
R8 (08h)	13	AIF_SEL	0b	Audio Interface Select 0 = Audio interface 1 1 = Audio interface 2 (GPIO3/BCLK2, GPIO4/DACLRC2, GPIO5/DACDAT2)
R9 (09h)	15	ALRCGPIO1	0b	ADCLRC/GPIO1 Pin Function Select 0 = ADCLRC 1 = GPIO1 (ADCLRC connected to DACLRC internally)
	14	ALRCGPIO6	0b	GPIO6/ADCLRCB Pin Function Select 0 = GPIO6 1 = Inverted ADCLRC clock output
	13	AIF_TRIS	0b	Audio Interface and GPIO Tristate 0 = Audio interface and GPIO pins operate normally 1 = Tristate all audio interface and GPIO pins

Table 45 GPIO and GPI Pin Function Select

The GPIO pins are also controlled by the register fields described in Table 46. Note the order of precedence described earlier applies.

Pull-up and pull-down resistors may be enabled on any of GPIO1 to GPIO6. If enabled, these settings take precedence over all other GPIO selections for that pin. Note that, by default, the pull-down resistors on GPIO2, GPIO3, GPIO4, GPIO5 and GPIO6 are enabled.

When the GPIO pins are used as inputs, de-bounce and interrupt masking may be controlled on all GPIO pins (including GPI7 and GPI8) using GPIO_n_DEB_ENA and GPIO_n_IRQ_ENA bits as shown in Table 47.

For each of GPIO1 to GPIO6, the register field GPIO_n_SEL is used to select the pin functions of the individual GPIO pins as shown in Table 47. Note that this control has the lowest precedence and is only effective when GPIO_n_PU, GPIO_n_PD, AIF_TRIS, AIFSEL, MCLK_SRC, ALRCGPIO1 and ALRCGPIO6 are set to allow GPIO functionality on that GPIO pin.

REGISTER ADDRESS	BIT	LABEL	DEFAULT	DESCRIPTION		
R19 (13h)	15	GPIO2_DEB_ENA	0b	See Table 47 for GPIO2 control bit description		
	14	GPIO2_IRQ_ENA	0b			
	13	GPIO2_PU	0b			
	12	GPIO2_PD	1b			
	11:8	GPIO2_SEL[3:0]	0000b			
	R19 (13h)	7	GPIO1_DEB_ENA	0b	See Table 47 for GPIO1 control bit description	
		6	GPIO1_IRQ_ENA	0b		
		5	GPIO1_PU	0b		
		4	GPIO1_PD	0b		
		3:0	GPIO1_SEL[3:0]	0000b		
R20 (14h)		15	GPIO4_DEB_ENA	0b		See Table 47 for GPIO4 control bit description
		14	GPIO4_IRQ_ENA	0b		
	13	GPIO4_PU	0b			
	12	GPIO4_PD	1b			
	11:8	GPIO4_SEL[3:0]	0000b			
	R20 (14h)	7	GPIO3_DEB_ENA	0b	See Table 47 for GPIO3 control bit description	
		6	GPIO3_IRQ_ENA	0b		
		5	GPIO3_PU	0b		
		4	GPIO3_PD	1b		
		3:0	GPIO3_SEL[3:0]	0000b		
R21 (15h)		15	GPIO6_DEB_ENA	0b		See Table 47 for GPIO6 control bit description
		14	GPIO6_IRQ_ENA	0b		
	13	GPIO6_PU	0b			
	12	GPIO6_PD	1b			
	11:8	GPIO6_SEL[3:0]	0000b			
	R21 (15h)	7	GPIO5_DEB_ENA	0b	See Table 47 for GPIO5 control bit description	
		6	GPIO5_IRQ_ENA	0b		
		5	GPIO5_PU	0b		
		4	GPIO5_PD	1b		
		3:0	GPIO5_SEL[3:0]	0000b		
R22 (16h)		7	GPI8_DEB_ENA	0b		See Table 47 for GPI n control bit description
		6	GPI8_IRQ_ENA	0b		
	4	GPI8_ENA	0b			
	R22 (16h)	3	GPI7_DEB_ENA	0b	See Table 47 for GPI n control bit description	
		2	GPI7_IRQ_ENA	0b		
		0	GPI7_ENA	0b		

Table 46 GPIO and GPI Control

The following table describes the coding of the fields listed in Table 46.

REGISTER ADDRESS	LABEL	DEFAULT	DESCRIPTION
Registers R19 (13h) to R21 (15h) (See Table 46)	GPIO _n _DEB_ENA (n = 1 to 8)	0b	De-Bounce 0 = disabled (Not de-bounced) 1 = enabled (Requires MCLK input and TOCLK_ENA = 1)
	GPIO _n _IRQ_ENA (n = 1 to 8)	0b	IRQ Enable 0 = disabled 1 = enabled
	GPIO _n _PU (n = 1 to 6)	0b	GPIO Pull-Up Resistor Enable 0 = Pull-up disabled 1 = Pull-up enabled (Approx 150kΩ)
	GPIO _n _PD (n = 1 to 6)	See Table 46	GPIO Pull-Down Resistor Enable 0 = Pull-down disabled 1 = Pull-down enabled (Approx 150kΩ)
	GPIO _n _SEL[3:0] (n = 1 to 6)	0000b	GPIO _n Pin Function Select 0000 = Input pin 0001 = Clock output (SYSCLK/OPCLKDIV) 0010 = Logic '0' 0011 = Logic '1' 0100 = PLL Lock output 0101 = Temperature OK output 0110 = SDO _{UT} data output 0111 = IRQ output 1000 = MIC Detect 1001 = MIC Short Circuit Detect 1010 to 1111 = Reserved
	GPIn_ENA (n = 7 or 8)	0b	GPIn Input Pin Enable 0 = pin disabled as GPIn input 1 = pin enabled as GPIn input

Table 47 GPIO Function Control Bits

The polarity of GPIO/GPI inputs may be configured using the GPIO_POL register bits. This is described in Table 48.

REGISTER ADDRESS	BIT	LABEL	DEFAULT	DESCRIPTION
R23 (17h)	7:0	GPIO_POL [7:0] (rw)	00h	GPIO _n Input Polarity 0 = Non-inverted 1 = Inverted GPIO_POL[7] = GPI8 polarity GPIO_POL[6] = GPI7 polarity GPIO_POL[5] = GPIO6 polarity GPIO_POL[4] = GPIO5 polarity GPIO_POL[3] = GPIO4 polarity GPIO_POL[2] = GPIO3 polarity GPIO_POL[1] = GPIO2 polarity GPIO_POL[0] = GPIO1 polarity

Table 48 GPIO Polarity

Each of the available GPIO functions is described in turn in the following sections.

ALTERNATIVE DAC INTERFACE

The WM8991 may be configured to select between two different audio interfaces, providing the capability to receive DAC input data via BCLK2, DACLRC2 and DACDAT2 instead of BCLK, DACLRC and DACDAT. This selection is made by register bit AIF_SEL, as described in Table 45.

To use the alternative DAC interface, the following register settings are required:

- AIF_TRIS = 0
- AIF_SEL = 1
- GPIO3_PU = 0, GPIO4_PU = 0, GPIO5_PU = 0
- GPIO3_PD = 0, GPIO4_PD = 0, GPIO5_PD = 0

Note that additional devices can also be connected to the main interface pins using the TDM mode. See "Digital Audio Interface" section for further details on controlling the audio interface pins.

The alternative DAC interface connection is illustrated in Figure 42.

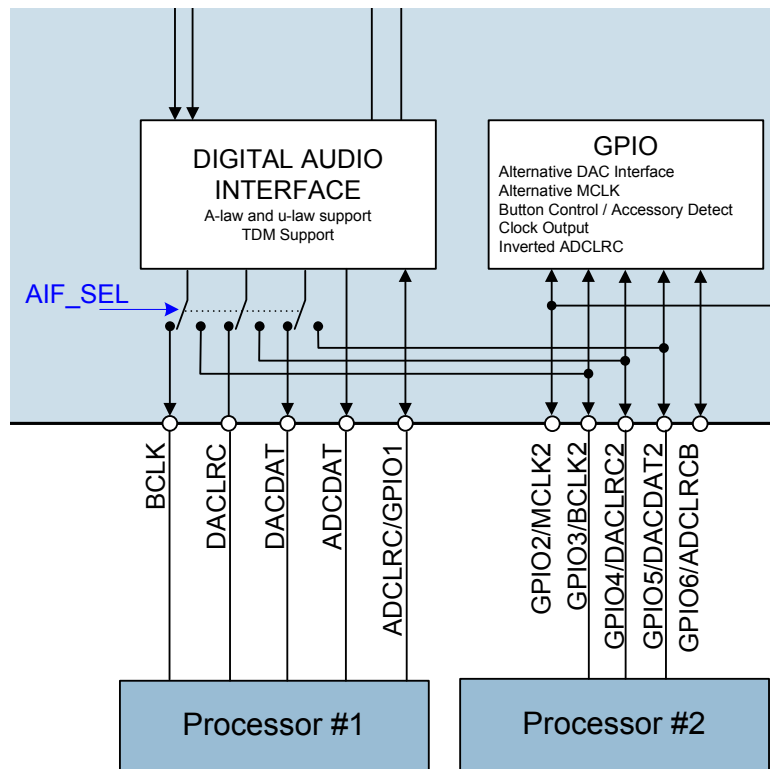

Figure 42 Alternative DAC Interface

BUTTON CONTROL

The WM8991 GPIO supports button control detection with full status readback for up to seven inputs (and one IRQ output). All inputs are latched at the IRQ Register, with de-bounce available for normal operation. De-bouncing may be disabled in order to allow the device to respond to wake-up events while the processor is disabled and is unable to provide a clock for de-bouncing.

To enable button control and accessory detection, the following register settings are required:

- ALRCGPIO1 = 1 (only required if using GPIO1)
- MCLK_SRC = 0 (only required if using GPIO2)
- AIF_SEL = 0 (only required if using GPIO3, GPIO4 or GPIO5)
- ALRCGPIO6 = 0 (only required if using GPIO6)
- LMN3 = 0, LLI3LO = 0 and RLI3LO = 0 (only required if using GPIO7)
- RMN3 = 0, RRI3LO = 0 and LRI3RO = 0 (only required if using GPIO8)
- AIF_TRIS = 0
- GPIO_n_SEL = 0000 for each required GPIO button input

Programmable pull-up and pull-down resistors are available on GPIO1 to GPIO6. These should be set according to the external circuit configuration. Note that pull-up and pull-down resistors are not available on the GPIO7 and GPIO8 input pins. Note that the analogue input paths to GPIO7 and GPIO8 must be disabled as described above when using these as digital inputs.

In this application, one or more of the GPIO pins may be configured as an Interrupt event if desired. This is controlled by the GPIO_n_IRQ_ENA bits described in Table 46. The GPIO Pin status fields contained in the IRQ Register (R18) may be read at any time or else in response to an Interrupt event. See Table 55 for more details of the Interrupt function.

An example configuration of the button control GPIO function is illustrated in Figure 43.

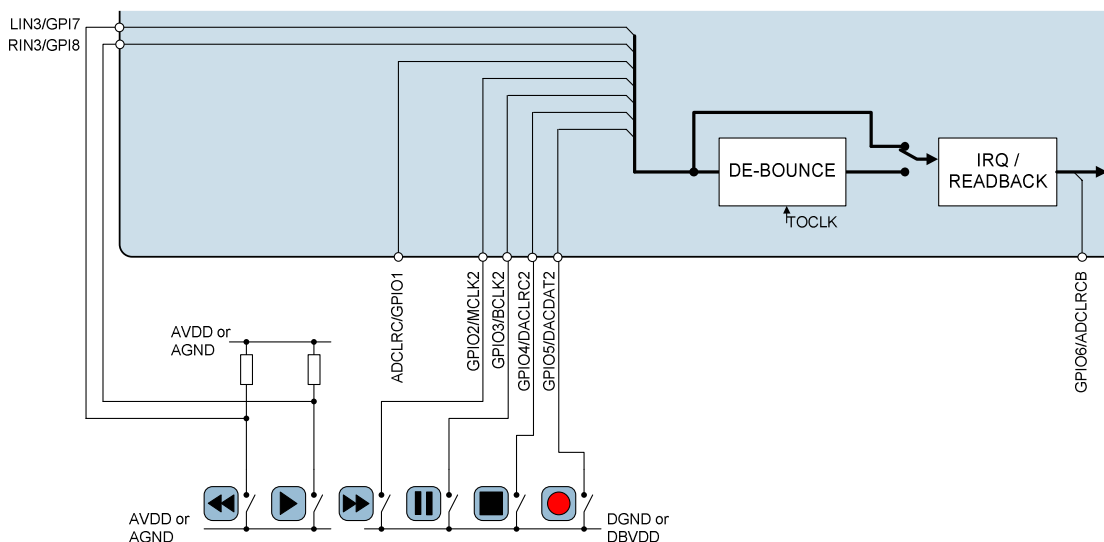

Figure 43 Example of Button Control Using GPIO Pins

Note:

- The GPIOs 1 to 6 are referenced to DBVDD
- The GPIOs 7 and 8 are referenced to AVDD

MICBIAS CURRENT AND ACCESSORY DETECT

A MICBIAS current detect function is provided for accessory detection. When a microphone current is detected (e.g. when a headset is inserted), an interrupt event can be generated and the microphone status read back via the control interface.

The MICBIAS current detect threshold is programmable. A short-circuit current detection is also available, with a programmable threshold. These functions are enabled by register bit MCD; the thresholds are programmable via register fields MCDTHR and MCDSCCTR as shown in Table 49.

The polarity of the current detect GPIO signals may be controlled by register bits MICDET_POL and MICSHRT_POL. Note that these polarity inversion bits apply to the Interrupt register behaviour only; they do not affect the direct GPIO output of the Current Detect functions. The respective interrupt events may be masked or enabled by register bits MICDET_IRQ_ENA and MICSHRT_IRQ_ENA. The MICBIAS current threshold status bits contained in the IRQ Register (R18) may be read at any time or else in response to an Interrupt event. See Table 55 for more details of the Interrupt function.

If direct output of the MICBIAS current detect function is required to the external pins of the WM8991, the following register settings are required:

- ALRCGPIO1 = 1 (only required if using GPIO1)
- MCLK_SRC = 0 (only required if using GPIO2)
- AIF_SEL = 0 (only required if using GPIO3, GPIO4 or GPIO5)
- ALRCGPIO6 = 0 (only required if using GPIO6)
- AIF_TRIS = 0
- GPIO_n_SEL = 1000 for the selected GPIO MICBIAS Current Detect output pin
- GPIO_n_SEL = 1001 for the selected GPIO MICBIAS Short Circuit Detect output pin
- GPIO_n_PU = 0 for the selected GPIO MICBIAS output pin or pins
- GPIO_n_PD = 0 for the selected GPIO MICBIAS output pin or pins

The register fields used to configure the MICBIAS Current Detect function are described in Table 49.

REGISTER ADDRESS	BIT	LABEL	DEFAULT	DESCRIPTION
R58 (3Ah)	7:6	MCDSC TH [1:0]	00b	MICBIAS Short Circuit Detect Threshold 00 = 600uA 01 = 1200uA 10 = 1800uA 11 = 2400uA These values are for AVDD=3.3V and scale proportionally with AVDD.
	5:3	MCDTHR [2:0]	000b	MICBIAS Current Detect Threshold 000 = 200uA 001 = 350uA 010 = 500uA 011 = 650uA 100 = 800uA 101 = 950uA 110 = 1100uA 111 = 1250uA These values are for AVDD=3.3V and scale proportionally with AVDD.
	2	MCD	0b	MICBIAS Current and Short Circuit Detect Enable 0 = disabled 1 = enabled
R23 (17h)	10	MICSHRT_POL (rw)	0b	MICBIAS short circuit detect polarity 0 = Non-inverted 1 = Inverted
	9	MICDET_POL (rw)	0b	MICBIAS current detect polarity 0 = Non-inverted 1 = Inverted
R22 (16h)	10	MICSHRT_IRQ_ENA	0b	MICBIAS short circuit detect IRQ Enable 0 = disabled 1 = enabled
	9	MICDET_IRQ_ENA	0b	MICBIAS current detect IRQ Enable 0 = disabled 1 = enabled

Table 49 MICBIAS Current Detect Control

The current detect function operates according to the following the truth table:

LABEL	VALUE	DESCRIPTION
Mic Short Circuit Detect	0	MCDSC TH current threshold not exceeded
Mic Short Circuit Detect	1	MCDSC TH current threshold exceeded
Mic Current Detect	0	MCDTHR current threshold not exceeded
Mic Current Detect	1	MCDTHR current threshold exceeded

Table 50 Truth Table for GPIO Output of MICBIAS Current Detect Function

ALTERNATIVE MCLK INPUT

An alternative MCLK source can be input via the MCLK2/GPIO2 pin. This provides additional flexibility for systems where the CODEC is required to interface with more than one processor. See "Clocking and Sample Rates" for more information on selecting MCLK source.

To enable the alternative MCLK input on GPIO2, the following register settings are required:

- MCLK_SRC = 1
- AIF_TRIS = 0
- GPIO2_PU = 0
- GPIO2_PD = 0
- GPIO2_SEL = 0000

The above register fields are described in Table 45 and Table 46.

CLOCK OUTPUT

A clock output (OPCLK) derived from SYSCLK may be output via GPIO1 to GPIO6. SYSCLK is derived from MCLK (either directly, or in conjunction with the PLL), and is used to provide all internal clocking for the WM8991 (see "Clocking and Sample Rates" section for more information).

A programmable clock divider OPCLKDIV controls the frequency of the OPCLK output. This clock is enabled by register bit OPCLK_ENA. See "Clocking and Sample Rates" for a definition of this register field.

To enable clock output via one or more GPIO pins, the following register settings are required:

- ALRCGPIO1 = 1 (only required if using GPIO1)
- MCLK_SRC = 0 (only required if using GPIO2)
- AIF_SEL = 0 (only required if using GPIO3, GPIO4 or GPIO5)
- ALRCGPIO6 = 0 (only required if using GPIO6)
- AIF_TRIS = 0
- GPIO_n_SEL = 0001 for the selected GPIO clock output pin
- GPIO_n_PU = 0 for the selected GPIO clock output pin
- GPIO_n_PD = 0 for the selected GPIO clock output pin

INVERTED ADCLRC OUTPUT

An inverted ADCLRC signal can be output via the GPIO6/ADCLRCB pin.

To enable the Inverted ADCLRC output, the following register settings are required:

- ALRCGPIO6 = 1
- AIF_TRIS = 0
- GPIO6_PU = 0
- GPIO6_PD = 0

TEMPERATURE SENSOR OUTPUT

The WM8991 output drivers can generate a large amount of heat. To protect the device from overheating a thermal shutdown function is provided (see "Thermal Shutdown" section for more information).

The polarity of the Thermal Shutdown sensor may be controlled by register bit TEMPOK_POL. Note that this polarity inversion bit applies to the Interrupt register behaviour only; it does not affect the direct GPIO output of the Temperature Sensor function. The associated interrupt event may be masked or enabled by register bit TEMPOK_IRQ_ENA. The Temperature status bit contained in the IRQ Register (R18) may be read at any time or else in response to an Interrupt event. See Table 55 for more details of the Interrupt function.

If direct output of the Temperature status bit is required to the external pins of the WM8991, the following register settings are required:

- ALRCGPIO1 = 1 (only required if using GPIO1)
- MCLK_SRC = 0 (only required if using GPIO2)
- AIF_SEL = 0 (only required if using GPIO3, GPIO4 or GPIO5)
- ALRCGPIO6 = 0 (only required if using GPIO6)
- AIF_TRIS = 0
- GPIO_n_SEL = 0101 for the selected GPIO Temperature status output pin
- GPIO_n_PU = 0 for the selected GPIO Temperature status output pin
- GPIO_n_PD = 0 for the selected GPIO Temperature status output pin

The register fields used to configure the Temperature Sensor GPIO function are described in Table 51.

REGISTER ADDRESS	BIT	LABEL	DEFAULT	DESCRIPTION
R23 (17h)	11	TEMPOK_POL (rw)	1b	Temperature Sensor polarity 0 = Non-inverted 1 = Inverted
R22 (16h)	11	TEMPOK_IRQ_ENA	0b	Temperature Sensor IRQ Enable 0 = disabled 1 = enabled

Table 51 Temperature Sensor GPIO Control

The temperature sensor function operates according to the following truth table:

LABEL	VALUE	DESCRIPTION
Temperature Sensor output	0	Overheat temperature exceeded
Temperature Sensor output	1	Overheat temperature not exceeded

Table 52 Truth table for GPIO Output of Temperature Sensor Function

PLL LOCK OUTPUT

An internal signal used to indicate the lock status of the PLL can be output to a GPIO pin or used to trigger an Interrupt event. The polarity of the PLL Lock indication may be controlled by register bit PLL_LCK_POL. Note that this polarity inversion bit applies to the Interrupt register behaviour only; it does not affect the direct GPIO output of the PLL Lock function. The associated interrupt event may be masked or enabled by register bit PLL_LCK_IRQ_ENA. The PLL Lock status bit in the IRQ Register (R18) may be read at any time or else in response to an Interrupt event. See Table 55 for more details of the Interrupt function.

If direct output of the PLL Lock status bit is required to the external pins of the WM8991, the following register settings are required:

- ALRCGPIO1 = 1 (only required if using GPIO1)
- MCLK_SRC = 0 (only required if using GPIO2)
- AIF_SEL = 0 (only required if using GPIO3, GPIO4 or GPIO5)
- ALRCGPIO6 = 0 (only required if using GPIO6)
- AIF_TRIS = 0
- GPIO_n_SEL = 0100 for the selected PLL Lock status output pin
- GPIO_n_PU = 0 for the selected PLL Lock status output pin
- GPIO_n_PD = 0 for the selected PLL Lock status output pin

The register fields used to configure the PLL Lock GPIO function are described in Table 53.

REGISTER ADDRESS	BIT	LABEL	DEFAULT	DESCRIPTION
R23 (17h)	8	PLL_LCK_POL (rw)	0b	PLL Lock polarity 0 = Non-inverted 1 = Inverted
R22 (16h)	8	PLL_LCK_IRQ_ENA	0b	PLL Lock IRQ Enable 0 = disabled 1 = enabled

Table 53 PLL Lock GPIO Control

The PLL Lock function operates according to the following truth table:

LABEL	VALUE	DESCRIPTION
PLL Lock output	0	PLL not Locked
PLL Lock output	1	PLL Locked

Table 54 Truth Table for GPIO Output of PLL Lock Function

LOGIC '1' AND LOGIC '0' OUTPUT

The GPIO pins can be programmed to drive a logic high or logic low signal. The following register settings are required:

- ALRCGPIO1 = 1 (only required if using GPIO1)
- MCLK_SRC = 0 (only required if using GPIO2)
- AIF_SEL = 0 (only required if using GPIO3, GPIO4 or GPIO5)
- ALRCGPIO6 = 0 (only required if using GPIO6)
- AIF_TRIS = 0
- GPIO_n_SEL = 0010 for each Logic '0' output pin
- GPIO_n_SEL = 0011 for each Logic '1' output pin
- GPIO_n_PU = 0 for each Logic '0' or Logic '1' GPIO pin
- GPIO_n_PD = 0 for each Logic '0' or Logic '1' GPIO pin

INTERRUPT EVENT OUTPUT

An interrupt can be generated by any of the following events described earlier:

- Button Control input (on GPIO1 to GPIO6, GPI7 and GPI8)
- MICBIAS current / short circuit / accessory detect
- PLL Lock
- Temperature Sensor

The interrupt status flag IRQ is asserted when any un-masked Interrupt input is asserted. It is the OR'd combination of all the un-masked Interrupt inputs. If required, this flag may be inverted using the IRQ_INV register bit. The GPIO pins can be configured to output the IRQ signal.

The interrupt behaviour is driven by level detection (not edge detection) of the un-masked inputs. Therefore, if an input remains asserted after the interrupt register has been reset, then the interrupt status flag IRQ will be triggered again even though no transition has occurred. If edge detection is required (eg. confirming that the input has been de-asserted), then the polarity inversion may be used after each event in order to detect each rising and falling edge separately. This is described further in the "GPIO Summary" section.

The status of the IRQ flag may be read back via the control interface. The status of each GPIO pin and the internal signals PLL_LCK, TEMPOK, MICSHRT and MICDET may also be read back in the same way.

The IRQ register (R18) is described in Table 55. The status of the GPIO pins or other Interrupt inputs can be read back via the read/write bits R18[11:0]. The Interrupt inputs are latched once set. Each input may be reset by writing a 1 to the appropriate bit. The IRQ bit cannot be reset; it is the OR'd combination of all other registers and will reset only if R18[11:0] are all 0.

If direct output of the Interrupt signal is required to external pins of the WM8991, the following register settings are required:

- ALRCGPIO1 = 1 (only required if using GPIO1)
- MCLK_SRC = 0 (only required if using GPIO2)
- AIF_SEL = 0 (only required if using GPIO3, GPIO4 or GPIO5)
- ALRCGPIO6 = 0 (only required if using GPIO6)
- AIF_TRIS = 0
- GPIO_n_SEL = 0111 for the selected Interrupt (IRQ) output pin
- GPIO_n_PU = 0 for the selected Interrupt (IRQ) output pin
- GPIO_n_PD = 0 for the selected Interrupt (IRQ) output pin

The IRQ register (R18) is described in Table 55.

REGISTER ADDRESS	BIT	LABEL	DEFAULT	DESCRIPTION
R18 (12h)	12	IRQ (ro)	Read Only	IRQ Readback (Allows polling of IRQ status)
	11	TEMPOK (rr)	Read or Reset	Temperature OK status Read- 0 = Device temperature NOT ok 1 = Device temperature ok Write - 1 = Reset TEMPOK latch
	10	MICSHRT (rr)	Read or Reset	MICBIAS short status Read- 0 = MICBIAS ok 1 = MICBIAS shorted Write- 1 = Reset MICSHRT latch
	9	MICDET (rr)	Read or Reset	MICBIAS detect status MICBIAS microphone detect Readback Read- 0 = No Microphone detected 1 = Microphone detected Write- 1 = Reset MICDET latch
	8	PLL_LCK (rr)	Read or Reset	PLL Lock status Read- 0 = PLL NOT locked 1 = PLL locked Write- 1 = Reset PLL_LCK latch
	7:0	GPIO_STATUS [7:0] (rr)	Read or Reset	GPIO and GPI Input Pin Status GPIO_STATUS[7] = GPI8 pin status GPIO_STATUS[6] = GPI7 pin status GPIO_STATUS[5] = GPIO6 status GPIO_STATUS[4] = GPIO5 status GPIO_STATUS[3] = GPIO4 status GPIO_STATUS[2] = GPIO3 status GPIO_STATUS[1] = GPIO2 status GPIO_STATUS[0] = GPIO1 status
R23 (17h) GPIO Control (2)	12	IRQ_INV (rw)	0b	IRQ Invert 0 = IRQ output active high 1 = IRQ output active low

Table 55 GPIO Interrupt and Status Readback

SERIAL DATA OUTPUT (REGISTER READBACK)

The GPIO pins can be configured to output serial data during register readback in 3-wire (open-drain) or 4-wire mode. The readback mode is configured using the register bits RD_3W_ENA and MODE_3W4W as described in Table 56.

Setting the RD_3W_ENA bit to 1 enables 3-wire readback using the SDIN pin in open-drain mode. Setting the RD_3W_ENA bit to 0 requires the use of a GPIO pin as SDOOUT. To enable SDOOUT on a GPIO pin, the following register settings are required:

- ALRCGPIO1 = 1 (only required if using GPIO1)
- MCLK_SRC = 0 (only required if using GPIO2)
- AIF_SEL = 0 (only required if using GPIO3, GPIO4 or GPIO5)
- ALRCGPIO6 = 0 (only required if using GPIO6)
- AIF_TRIS = 0
- GPIO_n_SEL = 0110 for the selected SDOOUT output pin
- GPIO_n_PU = 0 for the selected SDOOUT output pin
- GPIO_n_PD = 0 for the selected SDOOUT output pin

The register fields used to configure SDOOUT on the GPIO pins are described in Table 56. Refer to "Control Interface" for more details of 3-wire and 4-wire interfacing.

REGISTER ADDRESS	BIT	LABEL	DEFAULT	DESCRIPTION
R22 (16h)	15	RD_3W_ENA	1b	3- / 4-wire readback configuration 1 = 3-wire mode 0 = 4-wire mode, using GPIO pin
	14	MODE_3W4W	0b	3-wire mode 0 = push 0/1 1 = open-drain 4-wire mode 0 = push 0/1 1 = wired-OR

Table 56 GPIO 3-Wire Readback Enable

Details of the GPIO implementation are shown below. In order to avoid GPIO loops if a GPIO is configured as an output the corresponding input is disabled, as shown in Figure 45 below.

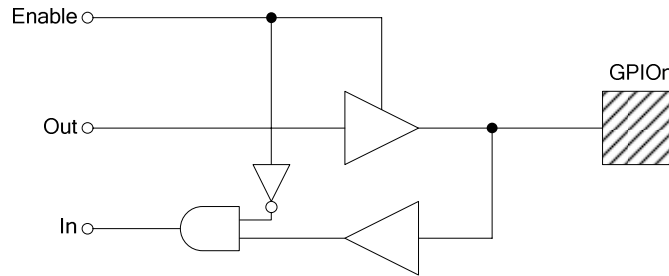

Figure 45 GPIO Pad

The GPIO register, i.e. latch structure, is shown in Figure 46 below. The de-bounce Control fields GPIO_n_DEB_ENA determine whether the signal is de-bounced or not. (Note that TOCLK (via SYSCLK) needs to be present in order for the debounce circuit to work.) The polarity bits GPIO_POL[7:0] control whether an interrupt is triggered by a logic 1 level (for GPIO_POL[n] = 0) or a logic 0 level (for GPIO_POL[n] = 1). The latch will cause the interrupt to be stored until it is reset by writing to the Interrupt Register. The latched signal is processed by the IRQ circuit, shown in Figure 44 above. The interrupt status bits can be read at any time from Register R18 (see Table 55) and are reset by writing a “1” to the applicable bit in Register R18.

Note that the interrupt behaviour is driven by level detection (not edge detection). Therefore, if an input remains asserted after the interrupt register has been reset, then the interrupt event will be triggered again even though no transition has occurred. If edge detection is required, this may be implemented as described in the following paragraphs.

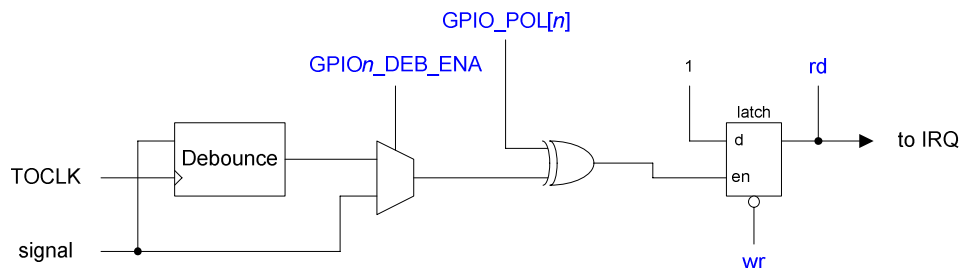

Figure 46 GPIO Function

Three typical scenarios are presented in the following Figure 47, Figure 48 and Figure 49. The examples are:

- Latch a GPIO input (Figure 47)
- Debounce and latch a GPIO input (Figure 48)
- Use the GPIO_n_POL bit to implement an IRQ edge detect function (Figure 49)

The GPIO input or internal Interrupt event (eg. MICBIAS current detect) is latched as illustrated below:

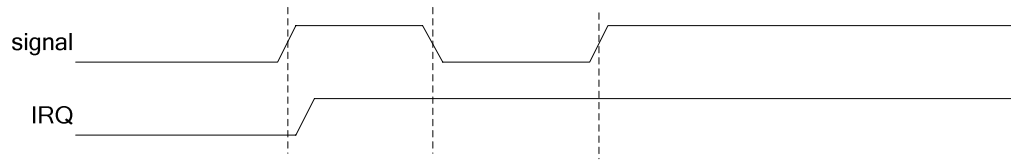

Figure 47 GPIO Latch

The de-bounce function on the GPIO input pins enables transient behaviour to be filtered as illustrated below:

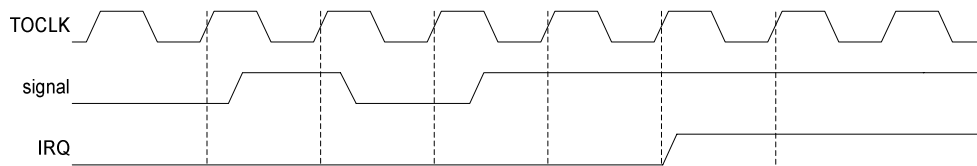

Figure 48 GPIO De-bounce

To implement an edge detect function on a GPIO input, the GPIO_n_POL bits may be used to alternate the GPIO polarity after each edge transition. For example, after a logic 1 has caused an Interrupt event, the polarity may be inverted prior to resetting the Interrupt register bit. In this way, the next interrupt event generated by this GPIO will occur when it returns to the logic 0 state. The GPIO_n_POL bit must be reversed after every GPIO edge transition, as illustrated below:

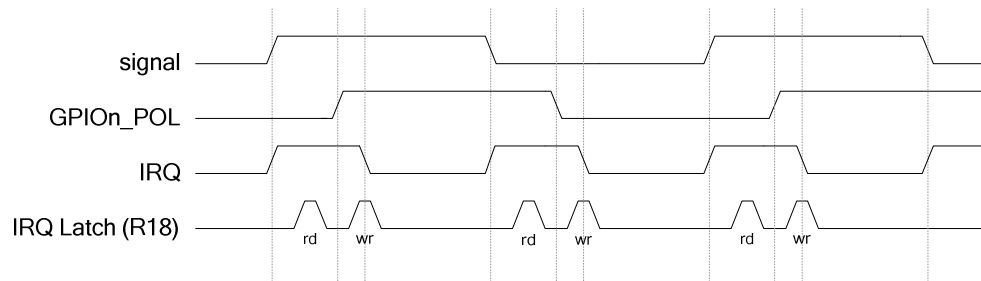

Figure 49 GPIO Edge Detect

GPIO IRQ HANDLING

In the following diagram Figure 50 a typical IRQ scenario is illustrated.

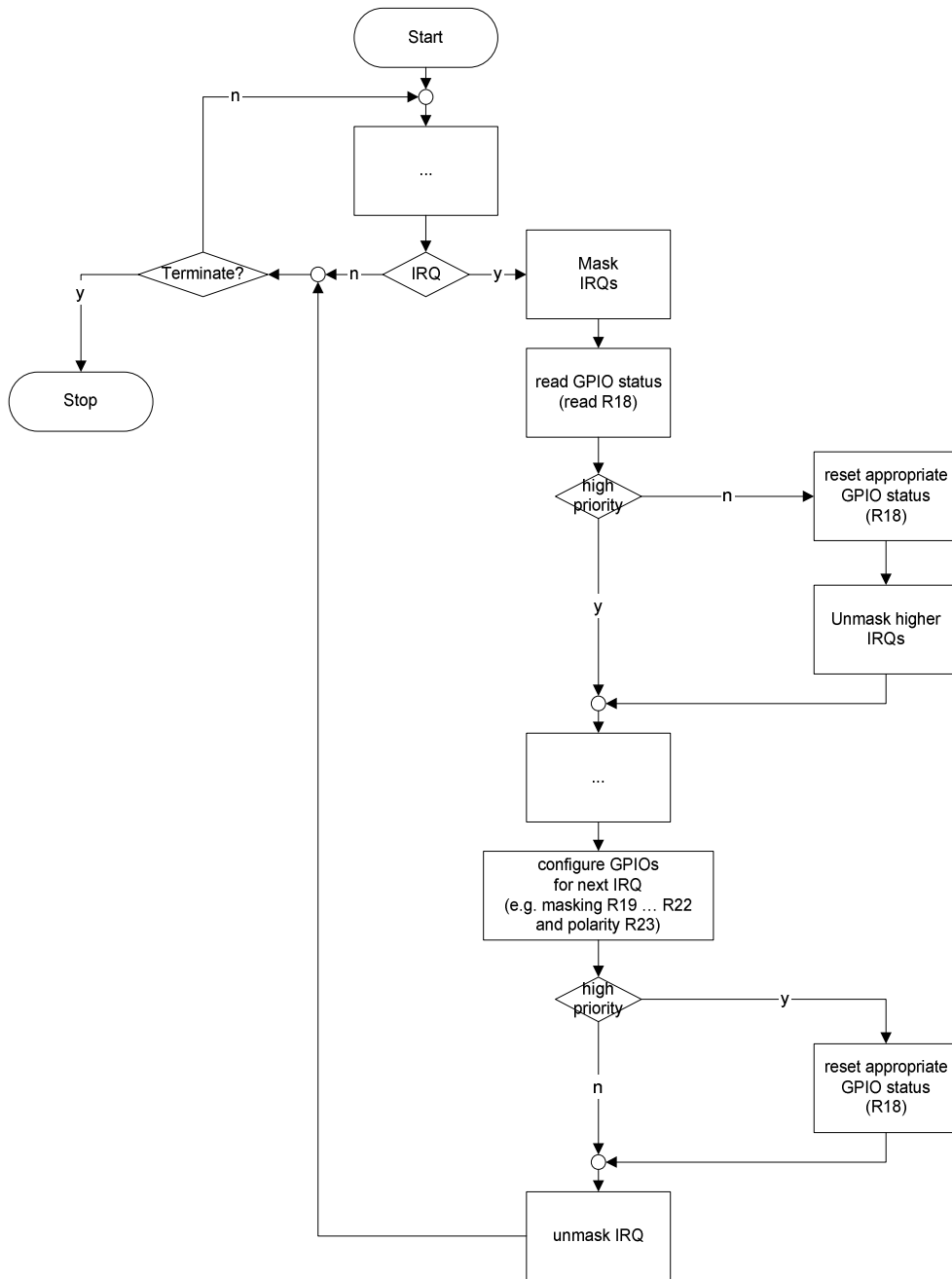

Figure 50 GPIO IRQ Handling

DIGITAL AUDIO INTERFACE

The digital audio interface is used for inputting DAC data to the WM8991 and outputting ADC data from it. It uses five pins:

- ADCDAT: ADC data output
- ADCLRC: ADC data alignment clock (An inverted ADCLRC is also available via GPIO)
- DACDAT: DAC data input (An alternative DACDAT is also available via GPIO)
- DACLRC: DAC data alignment clock (An alternative DACLRC is also available via GPIO)
- BCLK: Bit clock, for synchronisation (An alternative BCLK is also available via GPIO)

The clock signals BCLK, ADCLRC and DACLRC can be outputs when the WM8991 operates as a master, or inputs when it is a slave (see Master and Slave Mode Operation, below).

ADCLRC can also be configured as a GPIO pin. In this case, the ADC will use DACLRC as a frame clock. The ADCLRC/GPIO1 pin function should not be modified while the ADC is enabled.

DACDAT, DACLRC and BCLK functions can also be supported using GPIO pins. An inverted ADCLRC can also be output via GPIO pins.

Four different audio data formats are supported:

- Left justified
- Right justified
- I²S
- DSP mode

All four of these modes are MSB first. They are described in Audio Data Formats, below. Refer to the "Electrical Characteristics" section for timing information.

Time Division Multiplexing (TDM) is available in all four data format modes. The WM8991 can be programmed to send and receive data in one of two time slots.

PCM operation is supported using the DSP mode.

MASTER AND SLAVE MODE OPERATION

The WM8991 digital audio interface can operate as a master or slave as shown in Figure 51 and Figure 52.

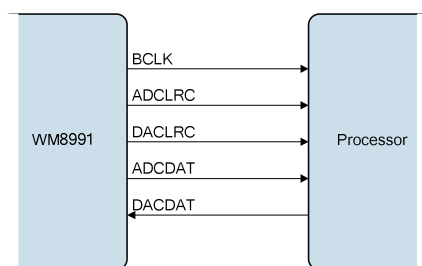

Figure 51 Master Mode

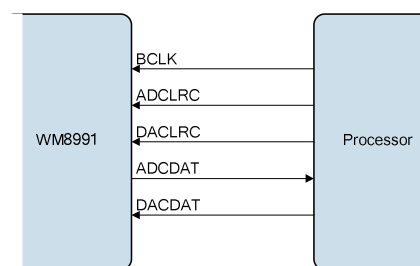

Figure 52 Slave Mode

OPERATION WITH ADCLRC AS GPIO

When the ADCLRC/GPIO1 pin is configured as a GPIO pin (ALRCGPIO=1), the DACLRC pin is used as a frame clock for ADCs and DACs as shown in Figure 53 and Figure 54. The ADCs and DACs must operate at the same sample rate in this configuration.

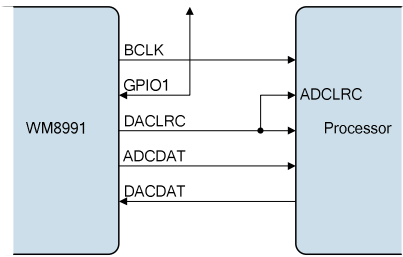

Figure 53 Master Mode with ADCLRC as GPIO

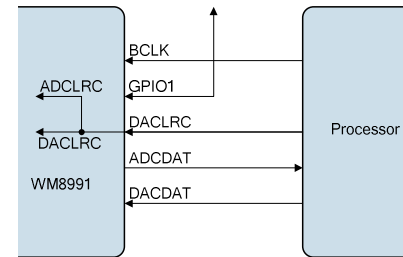

Figure 54 Slave Mode with ADCLRC as GPIO

OPERATION WITH ALTERNATIVE DAC INTERFACE

To allow data to be input to the WM8991 DACs from two separate sources, the GPIO[5:3] pins can be configured as an alternative DAC interface (BCLK2, DACLRC2, DACDAT2) as shown in Figure 57 to Figure 60.

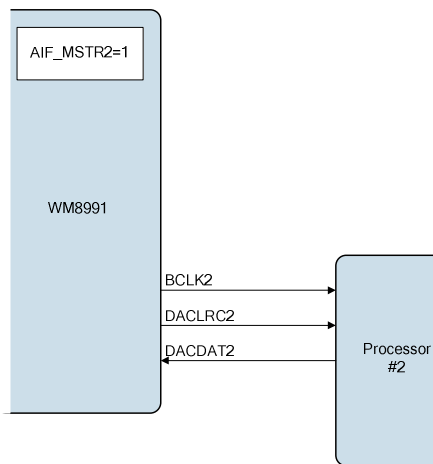

Figure 55 Interface 2 = Master

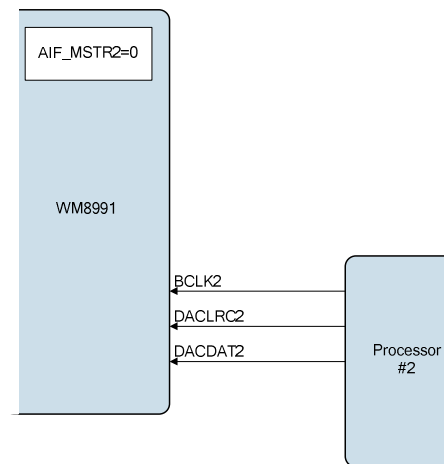

Figure 56 Interface 2 = Slave

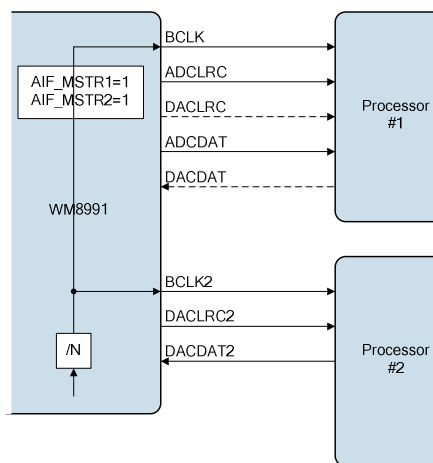

Figure 57 Interface 1 = Master, Interface 2 = Master

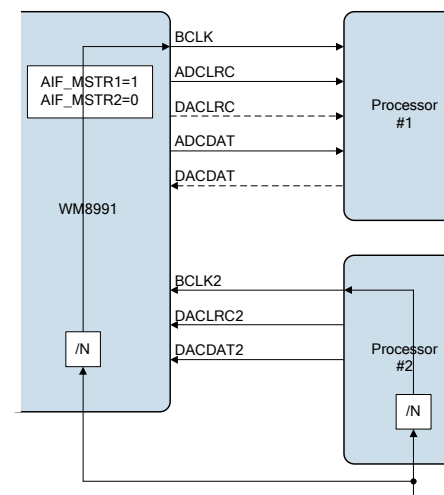

Figure 58 Interface 1 = Master, Interface 2 = Slave

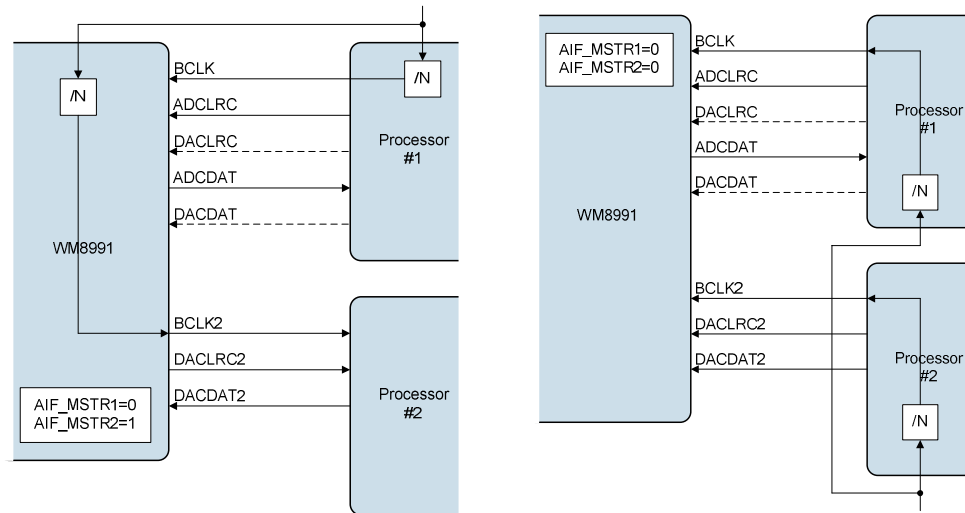

Figure 59 Interface 1 = Slave, Interface 2 = Master Figure 60 Interface 1 = Slave, Interface 2 = Slave

The dual Audio Interface approach of the WM8991 has been implemented in such a way that it gives the user and application as much flexibility as possible, without any restrictions built into the WM8991.

This means that the application has to be carefully analysed and the WM8991 configured accordingly. In the following Figure 61 and Figure 62 the Audio Interface input flow and the output controlling are illustrated.

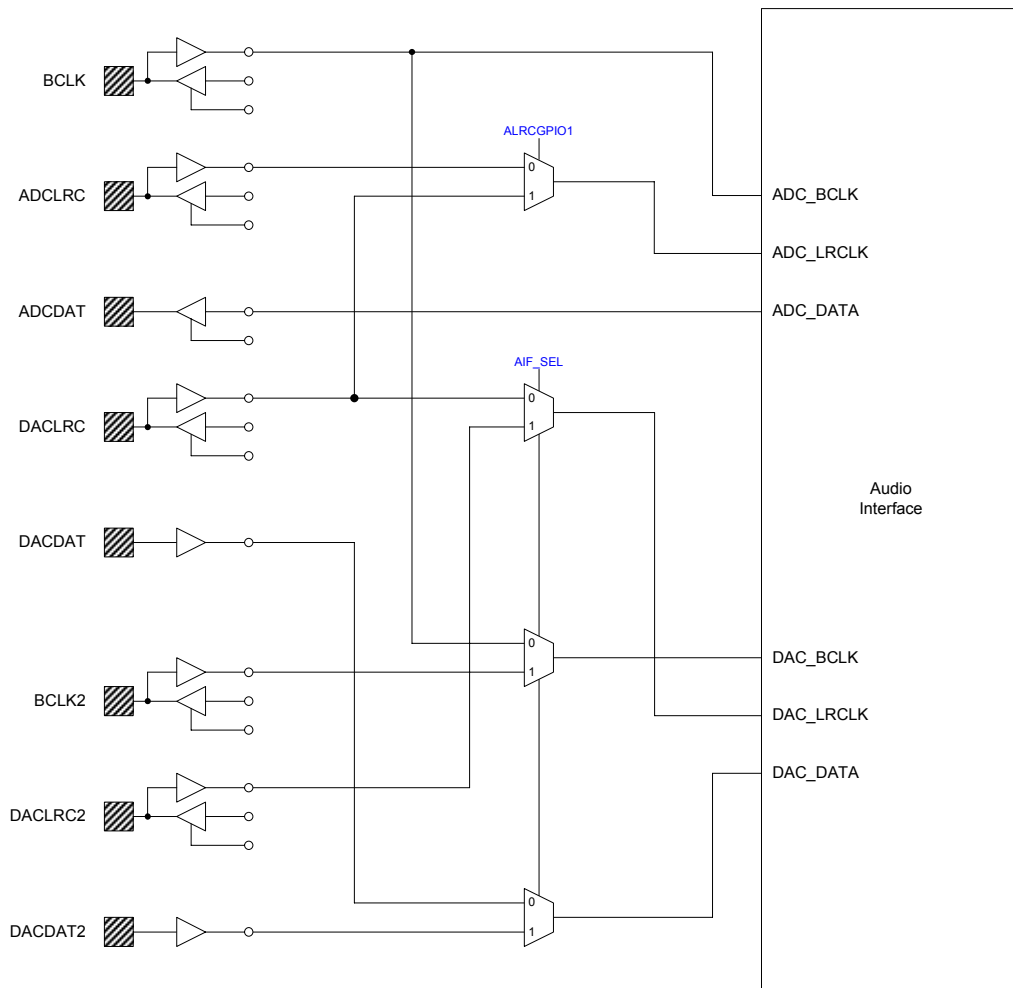

Figure 61 Audio Interface Input Flow

The Audio Interface input flow illustrated above is controlled by only two signals. These are ALRCGPIO1 and AIF_SEL.

REGISTER ADDRESS	BIT	LABEL	DEFAULT	DESCRIPTION
R8 (08h)	13	AIF_SEL	0b	Audio Interface Select 0 = Audio interface 1 1 = Audio interface 2 (GPIO3/BCLK2, GPIO4/DACLRC2, GPIO5/DACDAT2)
R9 (09h)	15	ALRCGPIO1	0b	ADCLRC/GPIO1 Pin Function Select 0 = ADCLRC pin 1 = GPIO1 pin (ADCLRC connected to DACLRC internally)

Table 57 Audio Interface Pin Function Select

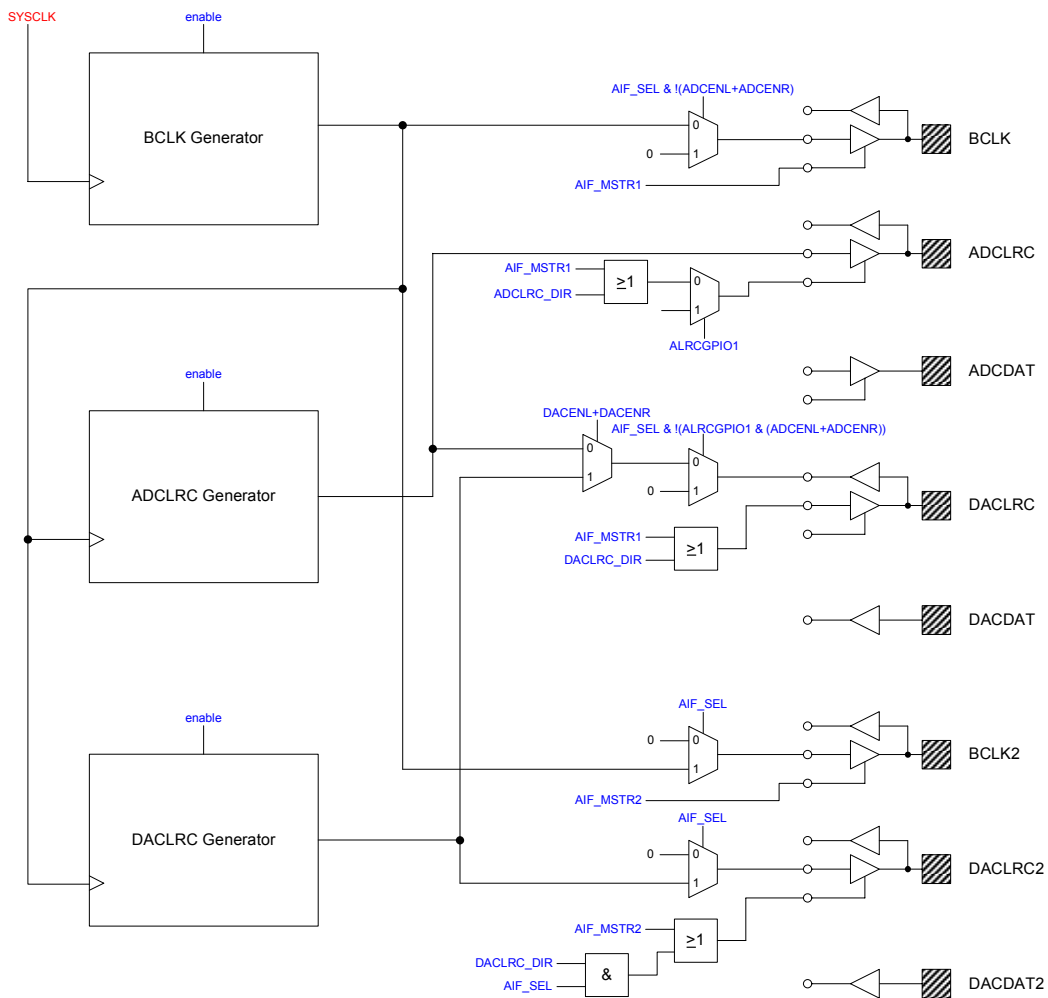

Figure 62 Audio Interface Output Control

The Audio Interface output control is illustrated above. The master mode control registers AIF_MSTR1 and AIF_MSTR2 as well as the left-right clock control registers ADCLRC_DIR and DACLRC_DIR determine whether the WM8991 generates the according clocks and AIF_SEL and ALRCGPIO1 control registers define the pins these clocks are provided from.

These registers are described in Table 58 below.

REGISTER ADDRESS	BIT	LABEL	DEFAULT	DESCRIPTION
R8 (08h)	15	AIF_MSTR1	0b	Audio Interface 1 Master Mode Select 0 = Slave mode 1 = Master mode
	14	AIF_MSTR2	0b	Audio Interface 2 Master Mode Select 0 = Slave mode 1 = Master mode
	13	AIF_SEL	0b	Audio Interface Select 0 = Audio interface 1 1 = Audio interface 2 (GPIO3/BCLK2, GPIO4/DACLRC2, GPIO5/DACDAT2)
	11	ADCLRC_DIR	0b	ADCLRC Direction (Forces ADCLRC clock to be output in slave mode) 0 = ADCLRC normal operation 1 = ADCLRC clock output enabled
R9 (09h)	15	ALRCGPIO1	0b	ADCLRC/GPIO1 Pin Function Select 0 = ADCLRC pin 1 = GPIO1 pin (ADCLRC connected to DACLRC internally)
	14	ALRCBGPIO6	0b	GPIO6/ADCLRCB Pin Function Select 0 = GPIO6 pin 1 = Inverted ADCLRC clock output
	11	DACLRC_DIR	0b	DACLRC Direction (Forces DACLRC clock to be output in slave mode) 0 = DACLRC normal operation 1 = DACLRC clock output enabled

Table 58 Audio Interface Output Function Control

OPERATION WITH TDM

Time division multiplexing (TDM) allows multiple devices to transfer data simultaneously on the same bus. The WM8991 ADCs and DACs support TDM in master and slave modes, on both interfaces, and for all data formats and word lengths. TDM is enabled using register bits AIFADC_TDM and AIFDAC_TDM. The TDM data slot is programmed using register bits AIFADC_TDM_CHAN and AIFDAC_TDM_CHAN.

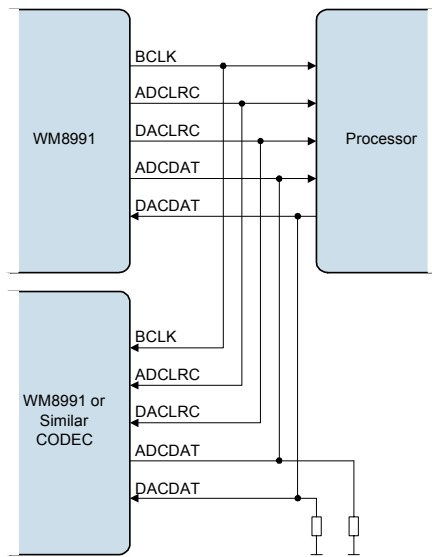

Figure 63 TDM with WM8991 as Master

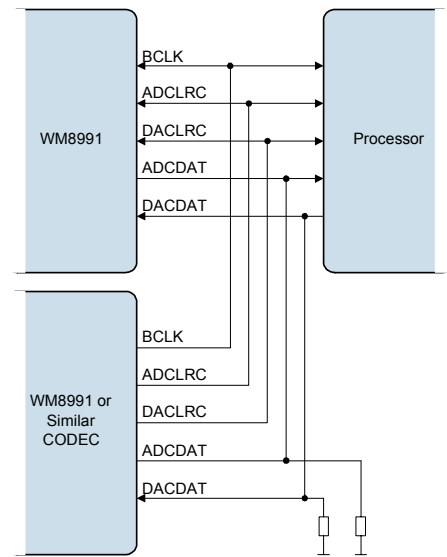

Figure 64 TDM with Other CODEC as Master

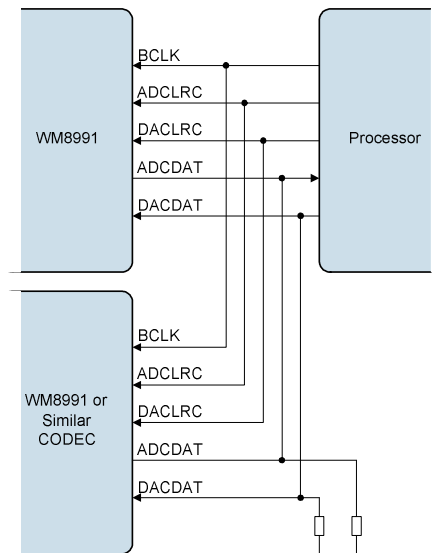

Figure 65 TDM with Processor as Master

Note: The WM8991 is a 24-bit device. If the user operates the WM8991 in 32-bit mode then the 8 LSBs will be ignored on the receiving side and not driven on the transmitting side. It is therefore recommended to add a pull-down resistor if necessary to the DACDAT line and the ADCDAT line in TDM mode.

BCLK DIVIDE

The BCLK frequency is controlled by BCLK_DIV. When the ADCs and DACs are operating at different sample rates, BCLK_DIV must be set appropriately to support the data rate of whichever is the faster.

Internal clock divide and phase control mechanisms ensure that the BCLK, ADCLRC and DACLRC edges will occur in a predictable and repeatable position relative to each other and to the data for a given combination of DAC sample rate, ADC sample rate and BCLK_DIV settings.

See "Clocking and Sample Rates" section for more information.

AUDIO DATA FORMATS (NORMAL MODE)

In Right Justified mode, the LSB is available on the last rising edge of BCLK before a LRCLK transition. All other bits are transmitted before (MSB first). Depending on word length, BCLK frequency and sample rate, there may be unused BCLK cycles after each LRCLK transition.

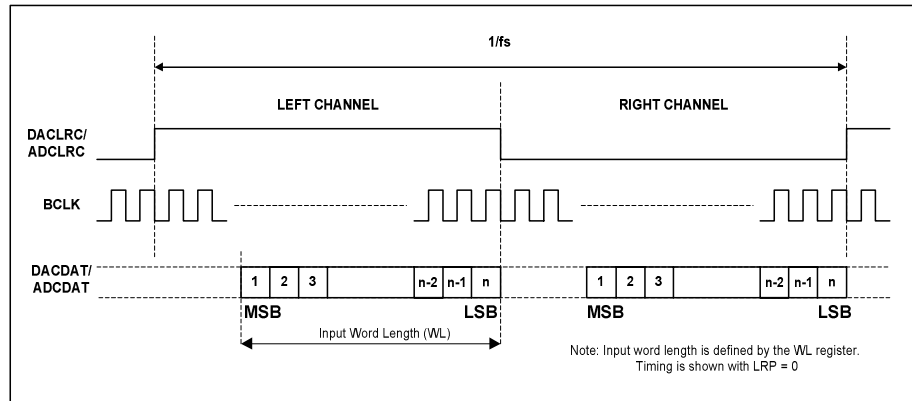

Figure 66 Right Justified Audio Interface (assuming n-bit word length)

In Left Justified mode, the MSB is available on the first rising edge of BCLK following a LRCLK transition. The other bits up to the LSB are then transmitted in order. Depending on word length, BCLK frequency and sample rate, there may be unused BCLK cycles before each LRCLK transition.

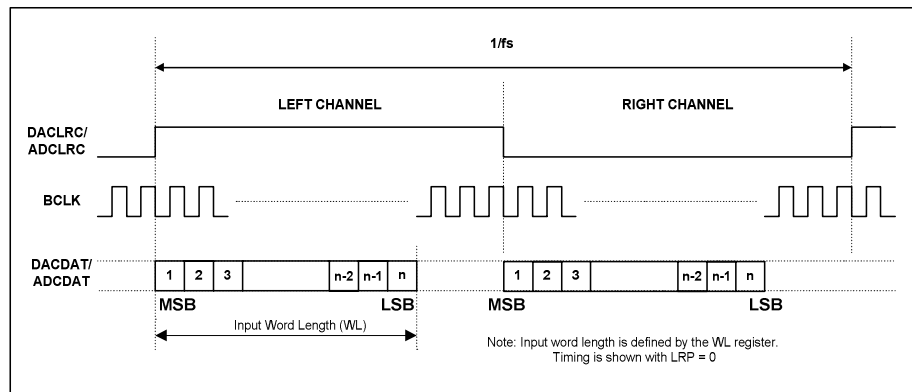

Figure 67 Left Justified Audio Interface (assuming n-bit word length)

In I²S mode, the MSB is available on the second rising edge of BCLK following a LRCLK transition. The other bits up to the LSB are then transmitted in order. Depending on word length, BCLK frequency and sample rate, there may be unused BCLK cycles between the LSB of one sample and the MSB of the next.

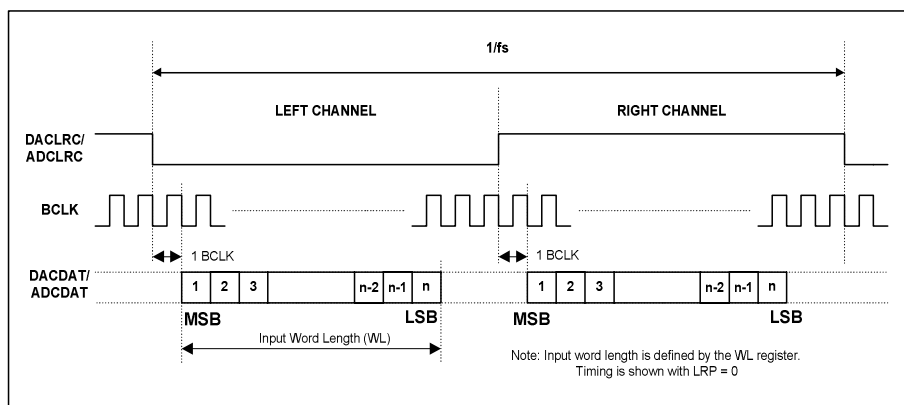

Figure 68 I2S Justified Audio Interface (assuming n-bit word length)

In DSP mode, the left channel MSB is available on either the 1st (mode B) or 2nd (mode A) rising edge of BCLK (selectable by AIF_LRCLK_INV) following a rising edge of LRC. Right channel data immediately follows left channel data. Depending on word length, BCLK frequency and sample rate, there may be unused BCLK cycles between the LSB of the right channel data and the next sample.

In device master mode, the LRC output will resemble the frame pulse shown in Figure 69 and Figure 70. In device slave mode, Figure 71 and Figure 72, it is possible to use any length of frame pulse less than 1/fs, providing the falling edge of the frame pulse occurs greater than one BCLK period before the rising edge of the next frame pulse.

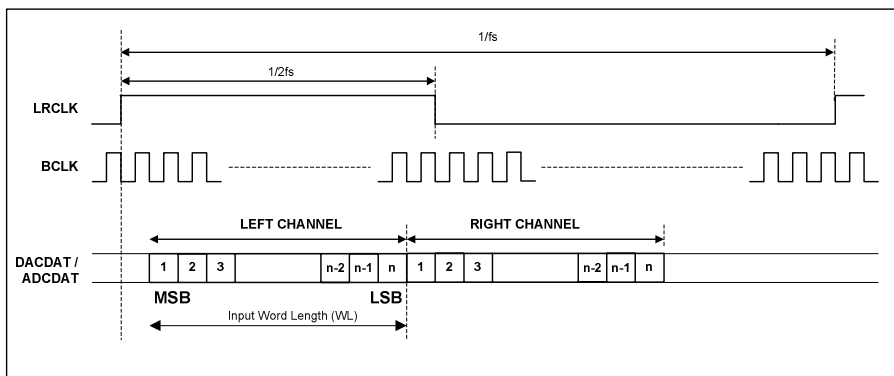

Figure 69 DSP Mode Audio Interface (mode A, AIF_LRCLK_INV=0, Master)

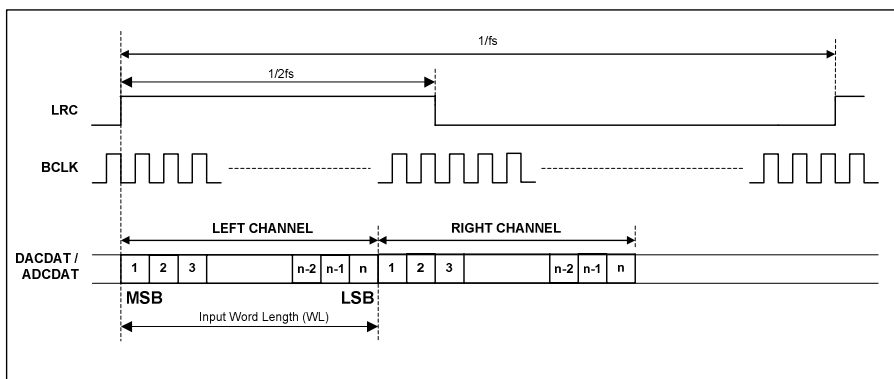

Figure 70 DSP Mode Audio Interface (mode B, AIF_LRCLK_INV=1, Master)

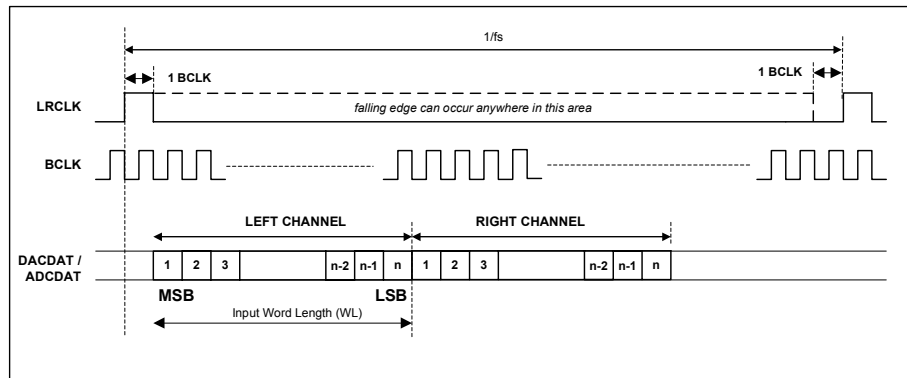

Figure 71 DSP Mode Audio Interface (mode A, AIF_LRCLK_INV=0, Slave)

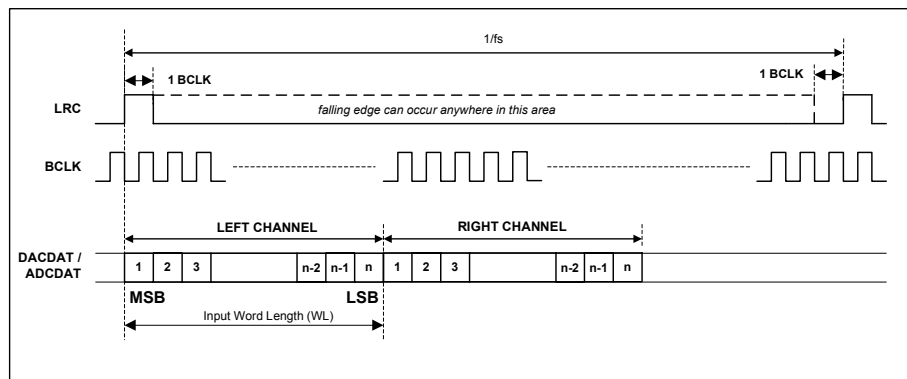

Figure 72 DSP Mode Audio Interface (mode B, AIF_LRCLK_INV=1, Slave)

PCM operation is supported in DSP interface mode. WM8991 ADC data that is output on the Left Channel will be read as mono PCM data by the receiving equipment. Mono PCM data received by the WM8991 will be treated as Left Channel data. This data may be routed to the Left/Right DACs as described in the “Digital Input Path” section.

AUDIO DATA FORMATS (TDM MODE)

TDM is supported in master and slave mode and is enabled by register bits AIF_ADC_TDM and AIF_DAC_TDM. All audio interface data formats support time division multiplexing (TDM) for ADC and DAC data.

Two time slots are available (Slot 0 and Slot 1), selected by register bits AIFADC_TDM_CHAN and AIFDAC_TDM_CHAN which control time slots for the ADC data and the DAC data.

When TDM is enabled, the ADCDAT pin will be tri-stated immediately before and immediately after data transmission, to allow another ADC device to drive this signal line for the remainder of the sample period. Note that it is important that two ADC devices do not attempt to drive the data pin simultaneously. A short circuit may occur if the transmission time of the two ADC devices overlap with each other. See “Audio Interface Timing - TDM Mode” for details of the ADCDAT output relative to BCLK signal. Note that it is possible to ensure a gap exists between transmissions by setting the transmitted word length to a value higher than the actual length of the data. For example, if 32-bit word length is selected where only 24-bit data is available, then the WM8991 interface will tri-state after transmission of the 24-bit data, ensuring a gap after the WM8991’s TDM slot.

When TDM is enabled, BCLK frequency must be high enough to allow data from both time slots to be transferred. The relative timing of Slot 0 and Slot 1 depends upon the selected data format as shown in Figure 74 to Figure 77.

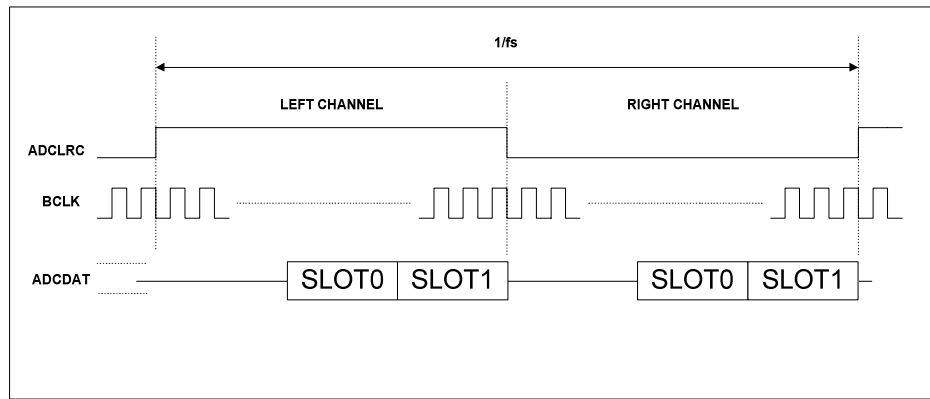

Figure 73 TDM in Right-Justified Mode

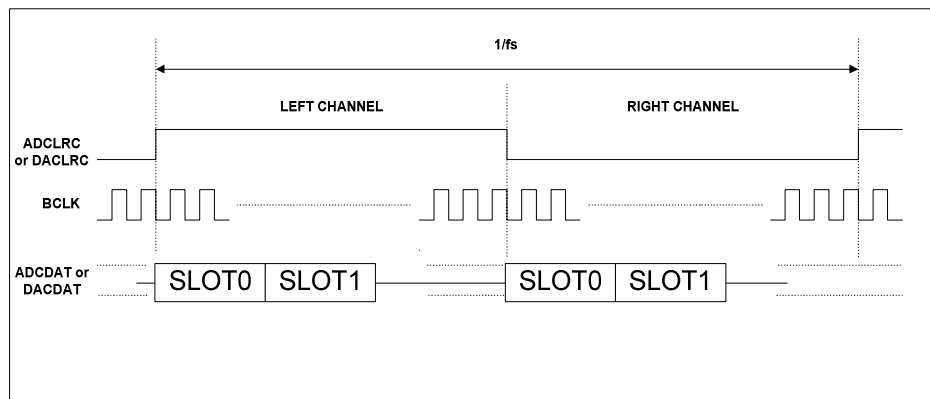

Figure 74 TDM in Left-Justified Mode

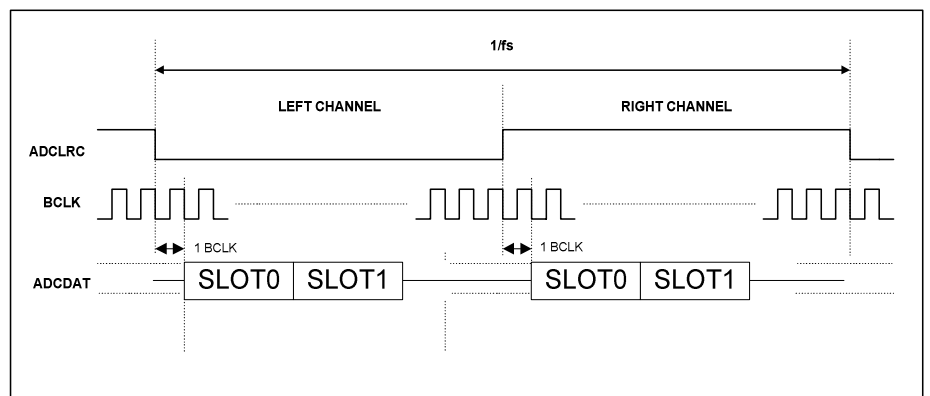

Figure 75 TDM in I^2S Mode

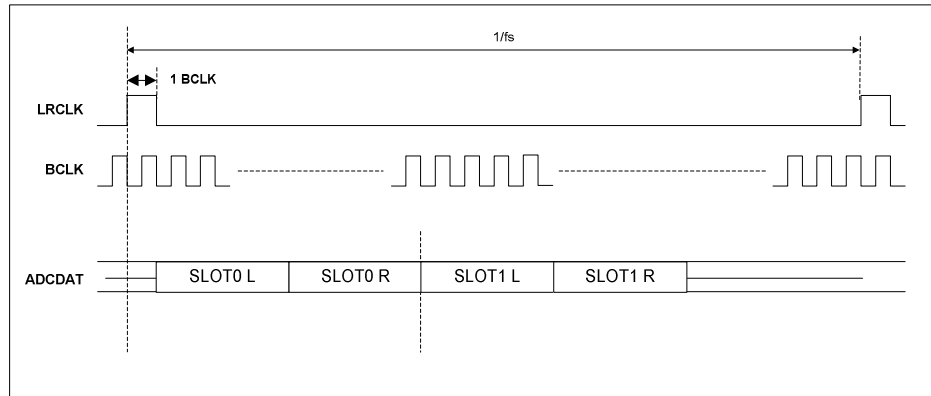

Figure 76 TDM in DSP Mode A

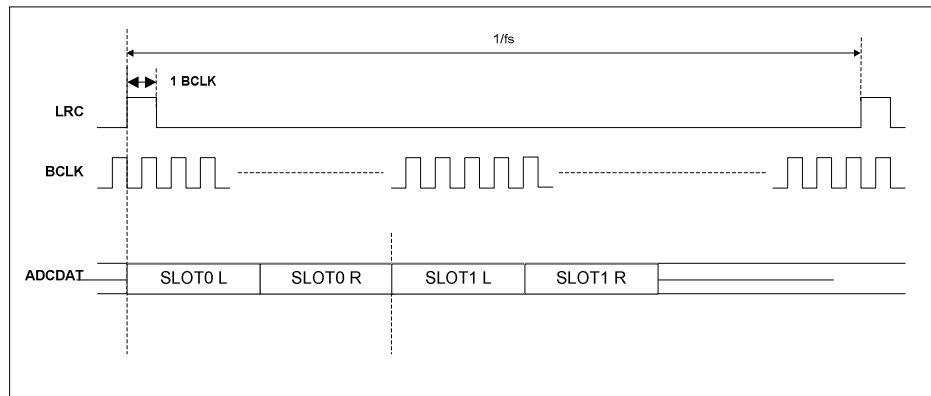

Figure 77 TDM in DSP Mode B

DIGITAL AUDIO INTERFACE CONTROL

The register bits controlling audio data format, word length, left/right channel data source and TDM are summarised in Table 59.

REGISTER ADDRESS	BIT	LABEL	DEFAULT	DESCRIPTION
R4 (04h)	15	AIFADCL_SRC	0b	Left ADC Data Source Select 0 = Left ADC data is output on left channel 1 = Right ADC data is output on left channel
	14	AIFADCR_SRC	1b	Right ADC Data Source Select 0 = Left ADC data is output on right channel 1 = Right ADC data is output on right channel
	13	AIFADC_TDM	0b	ADC TDM Enable 0 = Normal ADCDAT operation 1 = TDM enabled on ADCDAT
	12	AIFADC_TDM_CHAN	0b	ADCDAT TDM Channel Select 0 = ADCDAT outputs data on slot 0 1 = ADCDAT output data on slot 1
	8	AIF_BCLK_INV	0b	BCLK Invert 0 = BCLK not inverted 1 = BCLK inverted
	7	AIF_LRCLK_INV	0b	Right, left and I ² S modes – LRCLK polarity 0 = normal LRCLK polarity 1 = invert LRCLK polarity DSP Mode – mode A/B select 0 = MSB is available on 2nd BCLK rising edge after LRC rising edge (mode A) 1 = MSB is available on 1st BCLK rising edge after LRC rising edge (mode B)
	6:5	AIF_WL [1:0]	10b	Digital Audio Interface Word Length 00 = 16 bits 01 = 20 bits 10 = 24 bits 11 = 32 bits Note - see "Companding" for the selection of 8-bit mode
	4:3	AIF_FMT [1:0]	10b	Digital Audio Interface Format 00 = Right justified 01 = Left justified 10 = I ² S Format 11 = DSP Mode
R5 (05h)	15	DACL_SRC	0b	Left DAC Data Source Select 0 = Left DAC outputs left channel data 1 = Left DAC outputs right channel data
	14	DACR_SRC	1b	Right DAC Data Source Select 0 = Right DAC outputs left channel data 1 = Right DAC outputs right channel data
	12	AIFDAC_TDM	0b	DAC TDM Enable 0 = Normal DACDAT operation 1 = TDM enabled on DACDAT
	13	AIFDAC_TDM_CHAN	0b	DACDAT TDM Channel Select 0 = DACDAT data input on slot 0 1 = DACDAT data input on slot 1

Table 59 Audio Data Format Control

AUDIO INTERFACE OUTPUT AND GPIO TRISTATE

Register bit AIF_TRIS can be used to tristate the audio interface and GPIO pins as described in Table 60.

All GPIO[6:1] pins and digital audio interface pins will be tristated by this function, regardless of the state of other registers which control these pin configurations.

REGISTER ADDRESS	BIT	LABEL	DEFAULT	DESCRIPTION
R9 (09h)	13	AIF_TRIS	0	Audio Interface and GPIO Tristate 0 = Audio interface and GPIO pins operate normally 1 = Tristate all audio interface and GPIO pins

Table 60 Tri-stating the Audio Interface and GPIO Pins

MASTER MODE BCLK, ADCLRC AND DACLRC ENABLE

The main audio interface pins (BCLK, ADCLRC, ADCDAT, DACLRC and DACDAT) and the alternative DAC interface pins (BCLK2, DACLRC2, DACDAT2) can be independently programmed to operate in master mode or slave mode using register bits AIF_MSTR1 and AIF_MSTR2.

When the main audio interface is operating in slave mode, the BCLK, ADCLRC and DACLRC clock outputs to these pins are by default disabled to allow the digital audio source to drive these pins. Similarly, when the alternative audio interface is operating in slave mode, the BCLK2 and DACLRC2 clock outputs to these pins are by default disabled.

It is also possible to force the ADCLRC, DACLRC or DACLRC2 to be output using register bits ADCLRC_DIR and DACLRC_DIR, allowing mixed master and slave modes for the ADCs or the active DAC audio interface. The active audio interface is selected by register bit AIF_SEL. Enabled clock outputs on the de-selected audio interface will output logic 0.

When ADCLRC is configured as a GPIO pin (ALRCGPIO1=1), the DACLRC pin is used for the ADCs and the DACs and will only be disabled in master mode when both ADCs and both DACs are disabled.

The clock generators for the audio interface are enabled according to the control signals shown in Figure 78.

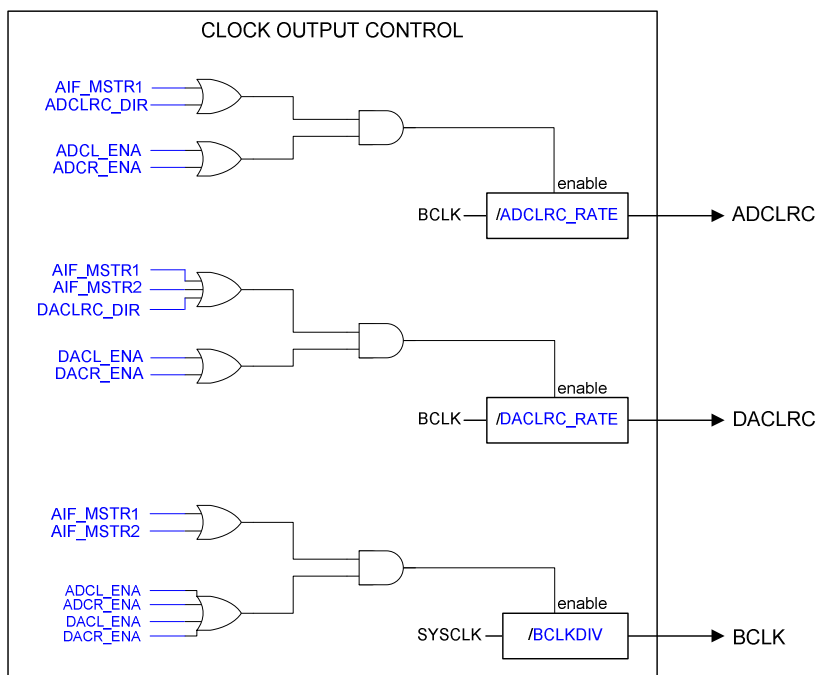

Figure 78 Clock Output Control

REGISTER ADDRESS	BIT	LABEL	DEFAULT	DESCRIPTION
R8 (08h)	15	AIF_MSTR1	0b	Audio Interface 1 Master Mode Select 0 = Slave mode 1 = Master mode
	14	AIF_MSTR2	0b	Audio Interface 2 Master Mode Select 0 = Slave mode 1 = Master mode
	13	AIF_SEL	0b	Audio Interface Select 0 = Audio interface 1 1 = Audio interface 2 (GPIO3/BCLK2, GPIO4/DACLRC2, GPIO5/DACDAT2)
	11	ADCLRC_DIR	0b	ADCLRC Direction (Forces ADCLRC clock to be output in slave mode) 0 = ADCLRC normal operation 1 = ADCLRC clock output enabled
	10:0	ADCLRC_RATE [10:0]	040h	ADCLRC Rate ADCLRC clock output = BCLK / ADCLRC_RATE Integer (LSB = 1) Valid from 8..2047
R9 (09h)	15	ALRCGPIO1	0b	ADCLRC/GPIO1 Pin Function Select 0 = ADCLRC pin 1 = GPIO1 pin (ADCLRC connected to DACLRC internally)
	11	DACLRC_DIR	0b	DACLRC Direction (Forces DACLRC clock to be output in slave mode) 0 = DACLRC normal operation 1 = DACLRC clock output enabled
	10:0	DACLRC_RATE [10:0]	040h	DACLRC Rate DACLRC clock output = BCLK / DACLRC_RATE Integer (LSB = 1) Valid from 8..2047

Table 61 Digital Audio Interface Clock Output Control

COMPANDING

The WM8991 supports A-law and μ -law companding on both transmit (ADC) and receive (DAC) sides as shown in Table 62.

REGISTER ADDRESS	BIT	LABEL	DEFAULT	DESCRIPTION
R5 (05h)	4	DAC_COMP	0b	DAC Companding Enable 0 = disabled 1 = enabled
	3	DAC_COMPMODE	0b	DAC Companding Type 0 = μ -law 1 = A-law
	2	ADC_COMP	0b	ADC Companding Enable 0 = disabled 1 = enabled
	1	ADC_COMPMODE	0b	ADC Companding Type 0 = μ -law 1 = A-law

Table 62 Companding Control

Companding involves using a piecewise linear approximation of the following equations (as set out by ITU-T G.711 standard) for data compression:

μ -law (where $\mu=255$ for the U.S. and Japan):

$$F(x) = \ln(1 + \mu|x|) / \ln(1 + \mu) \quad -1 \leq x \leq 1$$

A-law (where $A=87.6$ for Europe):

$$F(x) = A|x| / (1 + \ln A) \quad \text{for } x \leq 1/A$$

$$F(x) = (1 + \ln A|x|) / (1 + \ln A) \quad \text{for } 1/A \leq x \leq 1$$

The companded data is also inverted as recommended by the G.711 standard (all 8 bits are inverted for μ -law, all even data bits are inverted for A-law). The data will be transmitted as the first 8 MSBs of data.

Companding converts 13 bits (μ -law) or 12 bits (A-law) to 8 bits using non-linear quantization. This provides greater precision for low amplitude signals than for high amplitude signals, resulting in a greater usable dynamic range than 8 bit linear quantization. The companded signal is an 8-bit word comprising sign (1 bit), exponent (3 bits) and mantissa (4 bits).

8-bit mode is selected whenever DAC_COMP=1 or ADC_COMP=1. The use of 8-bit data allows samples to be passed using as few as 8 BCLK cycles per LRC frame. When using DSP mode B, 8-bit data words may be transferred consecutively every 8 BCLK cycles.

8-bit mode (without Companding) may be enabled by setting DAC_COMPMODE=1 or ADC_COMPMODE=1, when DAC_COMP=0 and ADC_COMP=0.

BIT7	BIT[6:4]	BIT[3:0]
SIGN	EXPONENT	MANTISSA

Table 63 8-bit Companded Word Composition

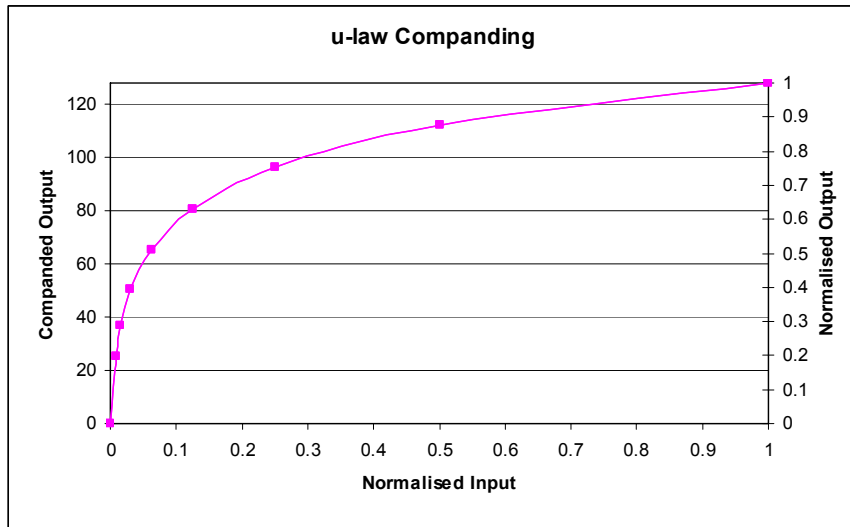

Figure 79 μ -Law Companding

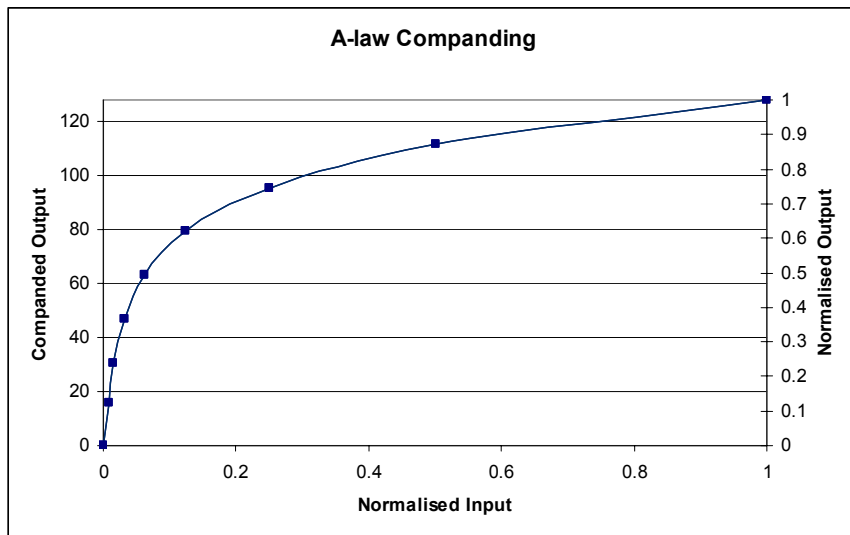

Figure 80 A-Law Companding

LOOPBACK

Setting the LOOPBACK register bit enables digital loopback. When this bit is set the output data from the ADC audio interface is fed directly into the DAC data input.

REGISTER ADDRESS	BIT	LABEL	DEFAULT	DESCRIPTION
R5 (05h)	0	LOOPBACK	0b	Digital Loopback Function 0 = No loopback 1 = Loopback enabled (ADC data output is directly input to DAC data input).

Table 64 Loopback Control**Note:**

1. Master Mode: ADC and DAC left/right clocks must be set to the same pin when using LOOPBACK function (ALRCGPIO1=1)
2. Slave Mode: It is recommended to set ALRCGPIO1=1 as well, otherwise ADCLRC and DACLRC must be running at the same BCLK rate and in phase.
3. When the digital sidetone is enabled, ADC data will continue to be added to DAC data when LOOPBACK is enabled

CLOCKING AND SAMPLE RATES

The internal clocks for the ADCs, DACs, DSP core functions, digital audio interface and Class D switching amplifier are all derived from a common internal clock source, SYSCLK.

SYSCLK can either be derived directly from MCLK, or may be generated from a PLL using MCLK as an external reference. Many commonly-used audio sample rates can be derived directly from typical MCLK frequencies; the PLL provides additional flexibility for a wide range of MCLK frequencies. An alternative MCLK input may be selected via the GPIO2/MCLK2 pin. All clock configurations must be set up before enabling playback to avoid glitches.

The ADC and DAC sample rates are independently selectable, relative to SYSCLK, using ADC_CLKDIV and DAC_CLKDIV. These fields must be set according to the required sampling frequency and depending on the selected clocking mode (AIF_LRCLKRATE).

In master mode, BCLK is also derived from SYSCLK via a programmable division set by BCLK_DIV. In the case where the ADCs and DACs are operating at different sample rates, BCLK must be set according to whichever is the faster rate. The ADCLRC and DACLRC signals do not automatically match the ADC and DAC sample rates; these must be configured using ADCLRC_RATE and DACLRC_RATE as described under "Digital Audio Interface Control".

A clock (OPCLK) derived from SYSCLK can be output on the GPIO pins to provide clocking for other parts of the system. This clock is enabled by OPCLK_ENA and its frequency is set by OPCLKDIV.

A slow clock (TOCLK) derived from SYSCLK can be used to de-bounce the button/accessory detect inputs, and to set the timeout period for volume updates when zero-cross detect is used. This clock is enabled by TOCLK_ENA and its frequency is set by TOCLK_RATE.

The Class D switching amplifier requires a clock; this is derived from SYSCLK via a programmable divider DCLKDIV.

Table 65 to Table 71 show the clocking and sample rate controls for MCLK input, BCLK output (in master mode), ADCs, DACs, class D outputs and GPIO clock output.

The overall clocking scheme for the WM8991 is illustrated in Figure 81.

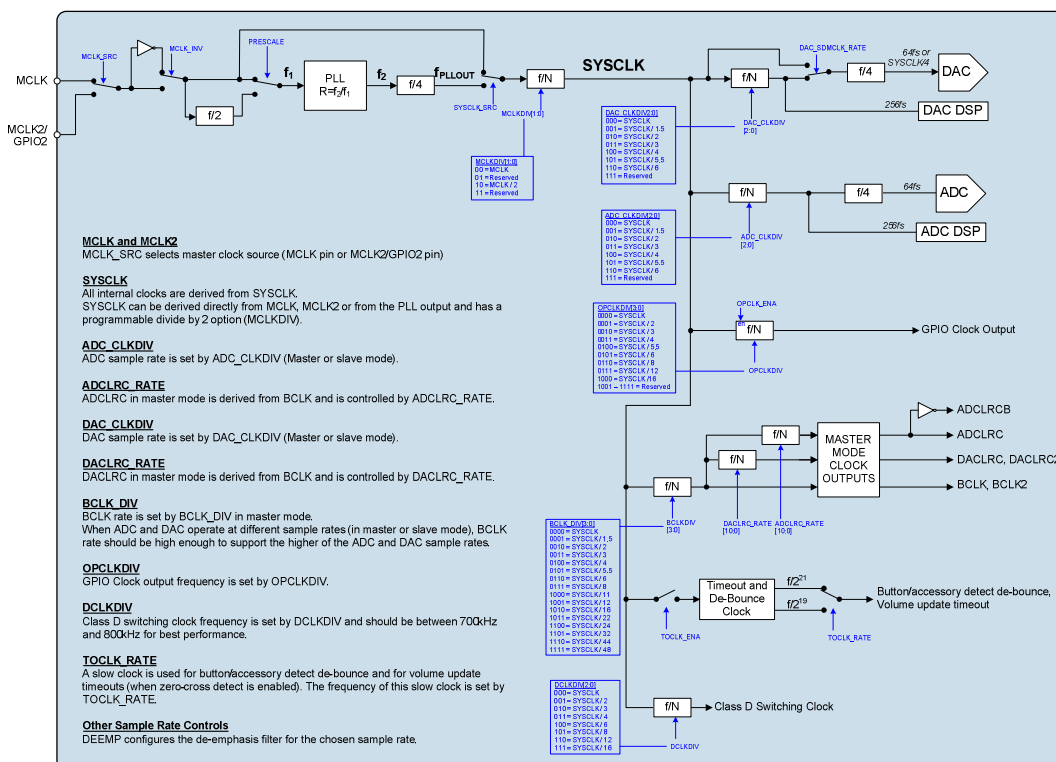

Figure 81 Clocking Scheme

SYSCLK CONTROL

The MCLK_SRC bit is used to select the MCLK source. The source may be either MCLK or GPIO2/MCLK2. The selected source may also be inverted by setting register bit MCLK_INV. Note that it is not recommended to change the control bit MCLK_INV while the WM8991 is processing data as this may lead to clock glitches and signal pop and clicks.

The SYSCLK_SRC bit is used to select the source for SYSCLK. The source may be either the selected MCLK source or the PLL output. The selected source is divided by the SYSCLK pre-divider MCLK_DIV to generate SYSCLK. The selected source may also be adjusted by the MCLK_DIV divider. These register fields are described in Table 65. See "PLL" for more details of the Phase Locked Loop clock generator.

The WM8991 supports glitch-free MCLK and SYSCLK source selection. When both clock sources are running and MCLK_SRC or SYSCLK_SRC is modified to select one of these clocks, a glitch-free clock transition will take place. The de-glitching circuit will ensure that the minimum pulse width will be no less than the pulse width of the faster of the two clock sources.

When the initial clock source is to be disabled before changing to the new clock source, the CLK_FORCE bit must also be used to force the clock source transition to take place. In this case, glitch-free operation cannot be guaranteed.

REGISTER ADDRESS	BIT	LABEL	DEFAULT	DESCRIPTION
R7 (07h)	15	MCLK_SRC	0b	MCLK Source Select 0 = MCLK pin 1 = GPIO2/MCLK2 pin
	14	SYSCLK_SRC	0b	SYSCLK Source Select 0 = MCLK (or MCLK2 if MCLK_SRC=1) 1 = PLL output
	13	CLK_FORCE	0b	Forces Clock Source Selection 0 = Existing SYSCLK source (MCLK, MCLK2 or PLL output) must be active when changing to a new clock source. 1 = Allows existing MCLK source to be disabled before changing to a new clock source.
	12:11	MCLK_DIV [1:0]	00b	SYSCLK Pre-divider. Clock source (MCLK, MCLK2 or PLL output) will be divided by this value to generate SYSCLK. 00 = Divide SYSCLK by 1 01 = Reserved 10 = Divide SYSCLK by 2 11 = Reserved
	10	MCLK_INV	0b	MCLK Invert 0 = Master clock (MCLK or MCLK2) not inverted 1 = Master clock (MCLK or MCLK2) inverted

Table 65 MCLK and SYSCLK Control

ADC / DAC SAMPLE RATES

The ADC and DAC sample rates are independently selectable, relative to SYSCLK, by setting the register fields ADC_CLKDIV and DAC_CLKDIV. These fields must be set according to the SYSCLK frequency, and according to the selected clocking mode.

Two clocking modes are provided - Normal Mode (AIF_LRCLKRATE = 0) allows selection of the commonly used sample rates from typical audio system clocking frequencies (eg. 12.288MHz); USB Mode (AIF_LRCLKRATE = 1) allows many of these sample rates to be generated from a 12MHz USB clock. Depending on the available clock sources, the USB mode may be used to save power by supporting 44.1kHz operation without requiring the PLL.

The AIF_LRCLKRATE field must be set as described in Table 66 to ensure correct operation of internal functions according to the SYSCLK / Fs ratio. Table 67 describes the available sample rates using four different common MCLK frequencies.

In Normal mode, the programmable division set by ADC_CLKDIV must ensure that a $256 * \text{ADC Fs}$ clock is generated for the ADC DSP. DAC_CLKDIV must ensure that a $256 * \text{DAC Fs}$ clock is generated for the DAC DSP.

In USB mode, the programmable division set by ADC_CLKDIV must ensure that a $272 * \text{ADC Fs}$ clock is generated for the ADC DSP. DAC_CLKDIV must ensure that a $272 * \text{DAC Fs}$ clock is generated for the DAC DSP.

Note that in USB mode, the ADC / DAC sample rates do not match exactly with the commonly used sample rates (e.g. 44.118 kHz instead of 44.100 kHz). At most, the difference is less than 0.5%. Data recorded at 44.100 kHz sample rate and replayed at 44.118 kHz will experience a slight (sub 0.5%) pitch shift as a result of this difference. Note also that the USB mode cannot be used to generate a 48kHz samples rate from a 12MHz MCLK; the PLL should be used in this case.

In low sample rate modes (eg. 8kHz voice), the SNR is liable to be degraded if the typical 64fs DAC clocking rate is used (see Figure 81). In this case, it may be possible to improve the SNR by raising the DAC clocking rate by setting the DAC_SDMCLK_RATE register field, causing the DAC clocking rate to be set equal to $\text{SYSCLK}/4$. The DAC_CLKDIV field must still be set as described above to derive the correct clock for the DAC DSP. In 8kHz voice applications, in systems where $\text{SYSCLK} > 256\text{fs}$ (or 272fs when applicable), setting DAC_SDMCLK_RATE will result in the SNR performance being improved. Note that setting DAC_SDMCLK_RATE will result in an increase in power consumption.

REGISTER ADDRESS	BIT	LABEL	DEFAULT	DESCRIPTION
R7 (07h)	7:5	ADC_CLKDIV [2:0]	000b	ADC Sample Rate Divider 000 = $\text{SYSCLK} / 1.0$ 001 = $\text{SYSCLK} / 1.5$ 010 = $\text{SYSCLK} / 2.0$ 011 = $\text{SYSCLK} / 3.0$ 100 = $\text{SYSCLK} / 4.0$ 101 = $\text{SYSCLK} / 5.5$ 110 = $\text{SYSCLK} / 6.0$ 111= Reserved
	4:2	DAC_CLKDIV [2:0]	000b	DAC Sample Rate Divider 000 = $\text{SYSCLK} / 1.0$ 001 = $\text{SYSCLK} / 1.5$ 010 = $\text{SYSCLK} / 2.0$ 011 = $\text{SYSCLK} / 3.0$ 100 = $\text{SYSCLK} / 4.0$ 101 = $\text{SYSCLK} / 5.5$ 110 = $\text{SYSCLK} / 6.0$ 111= Reserved
R10 (0Ah)	12	DAC_SDMCLK_RATE	0b	DAC clocking rate 0 = Normal operation (64fs) 1 = $\text{SYSCLK}/4$
	10	AIF_LRCLKRATE	0b	LRCLK Rate 0 = Normal mode ($256 * \text{fs}$) 1 = USB mode ($272 * \text{fs}$)

Table 66 ADC / DAC Sample Rate Control

SYCLK	ADC / DAC SAMPLE RATE DIVIDER	CLOCKING MODE	ADC / DAC SAMPLE RATE
12.288 MHz	000 = SYCLK / 1	Normal (256 * Fs)	48 kHz
	001 = SYCLK / 1.5		32 kHz
	010 = SYCLK / 2		24 kHz
	011 = SYCLK / 3		16 kHz
	100 = SYCLK / 4		12 kHz
	101 = SYCLK / 5.5		Not used
	110 = SYCLK / 6		8 kHz
	111 = Reserved		Reserved
11.2896 MHz	000 = SYCLK / 1	Normal (256 * Fs)	44.1 kHz
	001 = SYCLK / 1.5		Not used
	010 = SYCLK / 2		22.05 kHz
	011 = SYCLK / 3		Not used
	100 = SYCLK / 4		11.025 kHz
	101 = SYCLK / 5.5		8.018 kHz
	110 = SYCLK / 6		Not used
	111 = Reserved		Reserved
12 MHz	000 = SYCLK / 1	USB Mode (272 * Fs)	44.118 kHz
	001 = SYCLK / 1.5		Not used
	010 = SYCLK / 2		22.059 kHz
	011 = SYCLK / 3		Not used
	100 = SYCLK / 4		11.029 kHz
	101 = SYCLK / 5.5		8.021 kHz
	110 = SYCLK / 6		Not used
	111 = Reserved		Reserved
2.048 MHz	000 = SYCLK / 1	Normal (256 * Fs)	8 kHz
	001 = SYCLK / 1.5		Not used
	010 = SYCLK / 2		Not used
	011 = SYCLK / 3		Not used
	100 = SYCLK / 4		Not used
	101 = SYCLK / 5.5		Not used
	110 = SYCLK / 6		Not used
	111 = Reserved		Reserved

Table 67 ADC and DAC Sample Rates

BCLK CONTROL

In Master Mode, BCLK is derived from SYSCLK via a programmable division set by BCLK_DIV, as described in Table 68. BCLK_DIV must be set to an appropriate value to ensure that there are sufficient BCLK cycles to transfer the complete data words from the ADCs and to the DACs.

In Slave Mode, BCLK is generated externally and appears as an input to the CODEC. The host device must provide sufficient BCLK cycles to transfer complete data words to the ADCs and DACs.

Note that, although the ADC and DAC can run at different sample rates, they share the same bit clock pin BCLK. In the case where different ADC / DAC sample rates are used, the BCLK frequency should be set according to the higher of the ADC / DAC bit rates.

REGISTER ADDRESS	BIT	LABEL	DEFAULT	DESCRIPTION
R6 (06h)	4:1	BCLK_DIV [3:0]	0100b	BCLK Frequency (Master Mode) 0000 = SYSCLK 0001 = SYSCLK / 1.5 0010 = SYSCLK / 2 0011 = SYSCLK / 3 0100 = SYSCLK / 4 0101 = SYSCLK / 5.5 0110 = SYSCLK / 6 0111 = SYSCLK / 8 1000 = SYSCLK / 11 1001 = SYSCLK / 12 1010 = SYSCLK / 16 1011 = SYSCLK / 22 1100 = SYSCLK / 24 1101 = SYSCLK / 32 1110 = SYSCLK / 44 1111 = SYSCLK / 48

Table 68 BCLK Control

OPCLK CONTROL

A clock output (OPCLK) derived from SYSCLK may be output via GPIO1 to GPIO6. This clock is enabled by register bit OPCLK_ENA, and its frequency is controlled by OPCLKDIV.

This output of this clock is also dependent upon the GPIO register settings described under "General Purpose Input/Output".

REGISTER ADDRESS	BIT	LABEL	DEFAULT	DESCRIPTION
R6 (06h)	12:9	OPCLKDIV [3:0]	0000b	GPIO Output Clock Divider 0000 = SYSCLK 0001 = SYSCLK / 2 0010 = SYSCLK / 3 0011 = SYSCLK / 4 0100 = SYSCLK / 5.5 0101 = SYSCLK / 6 0110 = SYSCLK / 8 0111 = SYSCLK / 12 1000 = SYSCLK / 16 1001 to 1111 = Reserved
R2 (02h)	11	OPCLK_ENA (rw)	0b	GPIO Clock Output Enable 0 = disabled 1 = enabled

Table 69 OPCLK Control

CLASS D SWITCHING CLOCK

The Class D switching clock is derived from SYSCLK as determined by register field DCLKDIV as described in Table 70. This clock should be set to between 700kHz and 800kHz for optimum performance. The class D switching clock should not be disabled when the speaker output is active, as this will prevent the speaker outputs from functioning. The class D switching clock frequency should not be altered while the speaker output is active as this may generate an audible click.

REGISTER ADDRESS	BIT	LABEL	DEFAULT	DESCRIPTION
R6 (06h)	8:6	DCLKDIV [2:0]	111b	Class D Clock Divider 000 = SYSCLK 001 = SYSCLK / 2 010 = SYSCLK / 3 011 = SYSCLK / 4 100 = SYSCLK / 6 101 = SYSCLK / 8 110 = SYSCLK / 12 111 = SYSCLK / 16

Table 70 DCLK Control

TOCLK CONTROL

A slow clock (TOCLK) is derived from SYSCLK to enable input de-bouncing and volume update timeout functions. This clock is enabled by register bit TOCLK_ENA, and its frequency is controlled by TOCLK_RATE, as described in Table 71.

REGISTER ADDRESS	BIT	LABEL	DEFAULT	DESCRIPTION
R6 (06h)	15	TOCLK_RATE	0b	Timeout Clock Rate (Selects clock to be used for volume update timeout and GPIO input de-bounce) 0 = SYSCLK / 2 ²¹ (Slower Response) 1 = SYSCLK / 2 ¹⁹ (Faster Response)
	14	TOCLK_ENA	0b	Timeout Clock Enable (This clock is required for volume update timeout and GPIO input de-bounce) 0 = disabled 1 = enabled

Table 71 TOCLK Control

USB MODE

It is possible to reduce power consumption by disabling the PLL in some applications. One such application is when SYSCLK is generated from a 12MHz USB clock source. Setting the AIF_LRCLKRATE bit as described earlier (see "ADC / DAC Sample Rates") allows a sample rate close to 44.1kHz to be generated with no additional PLL power consumption.

In this configuration, SYSCLK must be driven directly from MCLK (or MCLK2) and by disabling the PLL. This is achieved by setting SYSCLK_SRC=0, PLL_ENA=0.

REGISTER ADDRESS	BIT	LABEL	DEFAULT	DESCRIPTION
R10 (0Ah)	10	AIF_LRCLKRATE	0b	LRCLK Rate 0 = Normal mode (256 * fs) 1 = USB mode (272 * fs)

Table 72 USB Mode Control

PLL

The integrated PLL can be used to generate SYSCLK for the WM8991 from a wide range of MCLK reference frequencies. The PLL is enabled by the PLL_ENA register bit. If required, the input reference clock can be divided by 2 by setting the register bit PRESCALE.

The PLL frequency ratio R is equal to f_2/f_1 (see Figure 81). This ratio is the real number represented by register fields PLLN and PLLK, where PLLN is an integer (LSB = 1) and PLLK is the fractional portion of the number (MSB = 0.5). The fractional portion is only valid when enabled by the field SDM. De-selection of fractional mode results in lower power consumption.

For PLL stability, input frequencies and divisions must be chosen so that $5 \leq \text{PLLN} \leq 13$. Best performance is achieved for $7 \leq N \leq 9$. Also, the PLL performs best when f_2 is set between 90MHz and 100MHz.

If PLLK is regarded as a 16-bit integer (instead of a fractional quantity), then PLLN and PLLK may be determined as follows:

- $\text{PLLN} = \text{int } R$
- $\text{PLLK} = \text{int } (2^{16} (R - \text{PLLN}))$

The PLL Control register settings are described in Table 73.

REGISTER ADDRESS	BIT	LABEL	DEFAULT	DESCRIPTION
R2 (02h)	15	PLL_ENA (rw)	0	PLL Enable 0 = disabled 1 = enabled
R60 (3Ch)	7	SDM	0	Enable PLL Integer Mode 0 = Integer mode 1 = Fractional mode
	6	PRESCALE	0b	Divide MCLK by 2 at PLL input 0 = Divide by 1 1 = Divide by 2
	3:0	PLLN [3:0]	8h	Integer (N) part of PLL frequency ratio.
R61 (3Dh)	7:0	PLLK [15:8]	31h	Fractional (K) part of PLL frequency ratio. (Most significant bits)
R62 (3Eh)	7:0	PLLK [7:0]	26h	Fractional (K) part of PLL frequency ratio. (Least significant bits)

Table 73 PLL Control

EXAMPLE PLL CALCULATION

To generate 12.288MHz SYSCLK from a 12MHz reference clock:

There is a fixed divide by 4 at the PLL output (see Figure 81) followed by a selectable divide by 2 in the same path. PLL output f_2 should be set in the range 90MHz - 100MHz. Enabling the divide by 2 (MCLK_DIV = 10b) sets the required $f_2 = 4 \times 2 \times 12.288\text{MHz} = 98.304\text{MHz}$.

There is a selectable pre-scale (divide MCLK by 2) at the PLL input (f_1 - see Figure 75). The PLL frequency ratio f_2/f_1 must be set in the range 5 - 13. Disabling the MCLK pre-scale (PRESCALE = 0b) sets the required ratio $f_2/f_1 = 8.192$.

The required settings for this example are:

- MCLK_DIV = 10b
- PRESCALE = 0b
- PLL_ENA = 1
- SDM = 1
- PLLN = 8 = 8h
- PLLK = 0.192 = 3126h

EXAMPLE PLL SETTINGS

Table 74 provides example PLL settings for generating common SYSCLK frequencies from a variety of MCLK reference frequencies.

MCLK (MHZ)	SYSCLK (MHZ)	MCLKDIV	F2 = SYSCLK * 4 * MCLKDIV	PRESCALE	F1 = MCLK/ PRESCALE	R = F2/F1	N	K
12	11.2896	2	90.3168	1	12	7.5264	7h	86C2h
12	12.288	2	98.304	1	12	8.192	8h	3126h
13	11.2896	2	90.3168	1	13	6.947446	6h	F28Bh
13	12.288	2	98.304	1	13	7.561846	7h	8FD5h
14.4	11.2896	2	90.3168	1	14.4	6.272	6h	45A1h
14.4	12.288	2	98.304	1	14.4	6.826667	6h	D3A0h
19.2	11.2896	2	90.3168	2	9.6	9.408	9h	6872h
19.2	12.288	2	98.304	2	9.6	10.24	Ah	3D70h
19.68	11.2896	2	90.3168	2	9.84	9.178537	9h	2DB4h
19.68	12.288	2	98.304	2	9.84	9.990243	9h	FD80h
19.8	11.2896	2	90.3168	2	9.9	9.122909	9h	1F76h
19.8	12.288	2	98.304	2	9.9	9.929697	9h	EE00h
24	11.2896	2	90.3168	2	12	7.5264	7h	86C2h
24	12.288	2	98.304	2	12	8.192	8h	3126h
26	11.2896	2	90.3168	2	13	6.947446	6h	F28Bh
26	12.288	2	98.304	2	13	7.561846	7h	8FD5h
27	11.2896	2	90.3168	2	13.5	6.690133	6h	B0ACh
27	12.288	2	98.304	2	13.5	7.281778	7h	4822h

Table 74 PLL Frequency Examples

CONTROL INTERFACE

The WM8991 is controlled by writing to its control registers. Readback is available for certain registers, including device ID, power management registers and some GPIO status bits. The control interface can operate as either a 2-, 3- or 4-wire control interface, with additional variants as detailed below:

1. 2-wire
 - open-drain
2. 3-wire
 - push 0/1
 - open drain
3. 4-wire
 - push 0/1
 - wired-OR

Readback is provided on the bi-directional pin SDIN in 2-/3-wire modes and on a GPIO pin in 4-wire mode.

SELECTION OF CONTROL MODE

The MODE pin determines the 2- or 3-/4-wire mode as shown in Table 75.

MODE	INTERFACE FORMAT
Low	2 wire
High	3- or 4- wire

Table 75 Control Interface Mode Selection

2-WIRE SERIAL CONTROL MODE

The WM8991 is controlled by writing to registers through a 2-wire serial control interface. A control word consists of 24 bits. The first 8 bits (B23 to B16) are address bits that select which control register is accessed. The remaining 16 bits (B15 to B0) are data bits, corresponding to the 16 bits in each control register. Many devices can be controlled by the same bus, and each device has a unique 7-bit address (this is not the same as the 8-bit address of each register in the WM8991). The default device address is 0011010 (0x34h).

The WM8991 operates as a slave device only. The controller indicates the start of data transfer with a high to low transition on SDIN while SCLK remains high. This indicates that a device address and data will follow. All devices on the 2-wire bus respond to the start condition and shift in the next eight bits on SDIN (7-bit address + Read/Write bit, MSB first). If the device address received matches the address of the WM8991, then the WM8991 responds by pulling SDIN low on the next clock pulse (ACK). If the address is not recognised or the R/W bit is '1' when operating in write only mode, the WM8991 returns to the idle condition and wait for a new start condition and valid address.

The WM8991 supports a multitude of read and write operations, which are:

- Single write
- Single read
- Multiple write using auto-increment
- Multiple read using auto-increment

These modes are shown in the section below. Terminology used in the following figures:

TERMINOLOGY		DESCRIPTION
S		Start Condition
Sr		Repeated start
A		Acknowledge
P		Stop Condition
R \bar{W}	ReadNotWrite	0 = Write 1 = Read

Table 76 Terminology

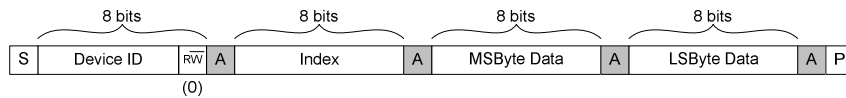

Figure 82 2-Wire Serial Control Interface (single write)

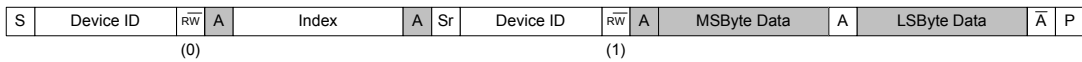

Figure 83 2-Wire Serial Control Interface (single read)

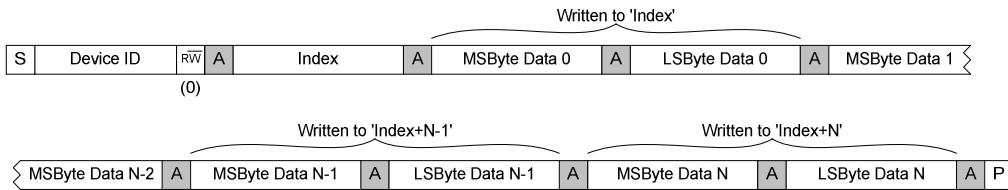

Figure 84 2-Wire Serial Control Interface (multiple write using auto-increment)

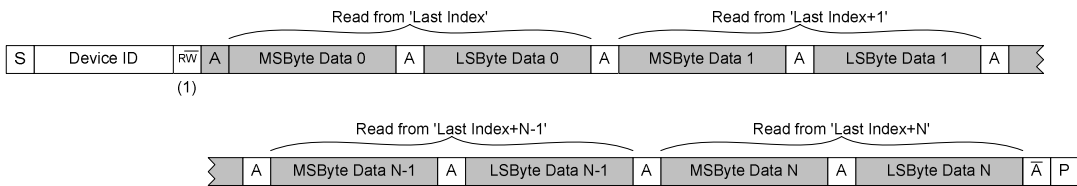

Figure 85 2-Wire Serial Control Interface (multiple read using auto-increment)

In 2-wire mode, the WM8991 has two possible device addresses, which can be selected using the CSB/ADDR pin.

CSB/ADDR STATE	DEVICE ADDRESS
Low	0011010 (0 x 34h)
High	0011011 (0 x 36h)

Table 77 2-Wire Control Interface Address Selection

3-WIRE / 4-WIRE SERIAL CONTROL MODES

The WM8991 is controlled by writing to registers through a 3- or 4-wire serial control interface. A control word consists of 24 bits. The first bit is the read/write bit (R/W), which is followed by 7 address bits (A6 to A0) that determine which control register is accessed. The remaining 16 bits (B15 to B0) are data bits, corresponding to the 16 bits in each control register.

The 3- or 4-wire modes are selected by the RD_3W_ENA register bit. Additionally the MODE_3W4W control bit can be used to select between push 0/1 and open-drain or wired-OR modes, as described in Table 78 below.

REGISTER ADDRESS	BIT	LABEL	DEFAULT	DESCRIPTION
R22 (16h)	15	RD_3W_ENA	1b	3- / 4-wire readback configuration 1 = 3-wire mode 0 = 4-wire mode, using GPIO pin
	14	MODE_3W4W	0b	3-wire mode 0 = push 0/1 1 = open-drain 4-wire mode 0 = push 0/1 1 = wired-OR

Table 78 3-Wire / 4-Wire Control Interface Selection

3-wire control mode is selected by setting RD_3W_ENA = 1. In 3-wire mode, every rising edge of SCLK clocks in one data bit from the SDIN pin. A rising edge on CSB/ADDR latches in a complete control word consisting of the last 24 bits.

In Write operations (R/W=0), all SDIN bits are driven by the controlling device.

In Read operations (R/W=1), the SDIN pin is driven by the controlling device to clock in the register address, after which the WM8991 drives the SDIN pin to output the applicable data bits.

The 3-wire control mode timing is illustrated in Figure 86.

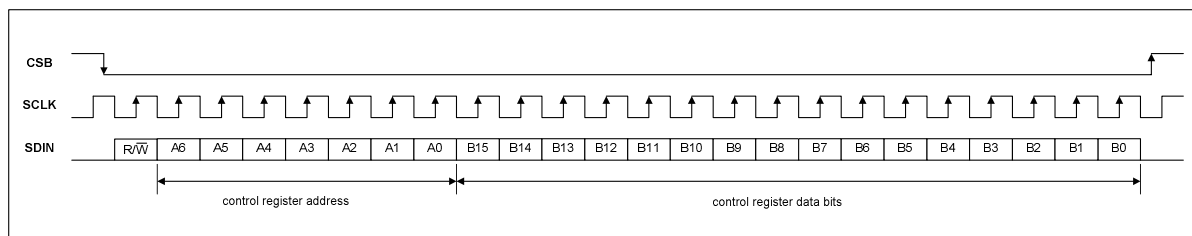

Figure 86 3-Wire Serial Control Interface

4-wire control mode is selected by setting RD_3W_ENA = 0.

In Write operations (R/W=0), this mode is the same as 3-wire mode described above.

In Read operations (R/W=1), a GPIO pin must be selected to output SDOOUT by setting GPIO_n_SEL=0110b (n= 1 to 6). In this mode, the SDIN pin is ignored following receipt of the valid register address. SDOOUT is driven by the WM8991.

In 4-wire Push 0/1 mode, SDOOUT is driven low when not outputting register data bits. In Wired-OR mode, SDOOUT is undriven when not outputting register data bits.

The 4-wire control mode timing is illustrated in Figure 87 and Figure 88.

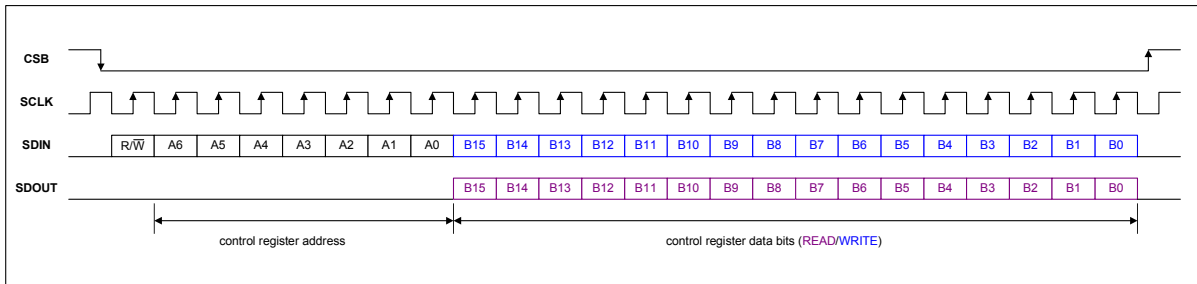

Figure 87 4-Wire Readback (Push 0/1)

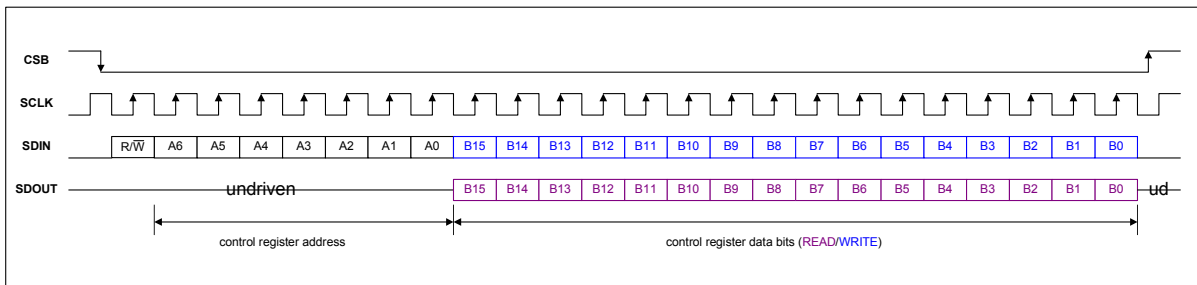

Figure 88 4-Wire Readback (wired-OR)

POWER MANAGEMENT

POWER MANAGEMENT REGISTERS

The WM8991 has three control registers that allow users to select which functions are active. For minimum power consumption, unused functions should be disabled. To minimise pop or click noise, it is important to enable or disable functions in the correct order. See "Pop Suppression Control" for further details of recommended control sequences.

REGISTER ADDRESS	BIT	LABEL	DEFAULT	DESCRIPTION
R1 (1h)	12	SPK_ENA (rw)	0b	SPKMIX Mixer, Speaker PGA and Speaker Output Enable 0 = disabled 1 = enabled
	11	OUT3_ENA (rw)	0b	OUT3 and OUT3MIX Enable 0 = disabled 1 = enabled
	10	OUT4_ENA (rw)	0b	OUT4 and OUT4MIX Enable 0 = disabled 1 = enabled
	9	LOUT_ENA (rw)	0b	LOUT (Left Headphone Output) Enable 0 = disabled 1 = enabled
	8	ROUT_ENA (rw)	0b	ROUT (Right Headphone Output) Enable 0 = disabled 1 = enabled
	4	MICBIAS_ENA (rw)	0b	MICBIAS Enable 0 = OFF (high impedance output) 1 = ON
	2:1	VMID_MODE [1:0] (rw)	00b	Vmid Divider Enable and Select 00 = Vmid disabled (for OFF mode) 01 = 2 x 50kΩ divider (Normal mode) 10 = 2 x 250kΩ divider (Standby mode) 11 = 2 x 5kΩ divider (for fast start-up)
	0	VREF_ENA (rw)	0b	VREF Enable (Bias for all analogue functions) 0 = VREF bias disabled 1 = VREF bias enabled
R2 (02h)	15	PLL_ENA (rw)	0b	PLL Enable 0 = disabled 1 = enabled
	14	TSHUT_ENA (rw)	0b	Thermal Sensor Enable 0 = Thermal sensor disabled 1 = Thermal sensor enabled
	13	TSHUT_OPDIS (rw)	1b	Thermal Shutdown Enable (Requires thermal sensor to be enabled) 0 = Thermal shutdown disabled 1 = Thermal shutdown enabled
	11	OPCLK_ENA (rw)	0b	GPIO Clock Output Enable 0 = disabled 1 = enabled
	9	AINL_ENA (rw)	0b	Left Input Path Enable (Enables AINLMUX, INMIXL, DIFFINL and RXVOICE input to AINLMUX) 0 = disabled 1 = enabled

REGISTER ADDRESS	BIT	LABEL	DEFAULT	DESCRIPTION
	8	AINR_ENA (rw)	0b	Left Input Path Enable (Enables AINRMUX, INMIXR, DIFFINR and RXVOICE input to AINRMUX) 0 = disabled 1 = enabled
	7	LIN34_ENA (rw)	0b	LIN34 Input PGA Enable 0 = disabled 1 = enabled
	6	LIN12_ENA (rw)	0b	LIN12 Input PGA Enable 0 = disabled 1 = enabled
	5	RIN34_ENA (rw)	0b	RIN34 Input PGA Enable 0 = disabled 1 = enabled
	4	RIN12_ENA (rw)	0b	RIN12 Input PGA Enable 0 = disabled 1 = enabled
	1	ADCL_ENA (rw)	0b	Left ADC Enable 0 = disabled 1 = enabled
	0	ADCR_ENA (rw)	0b	Right ADC Enable 0 = disabled 1 = enabled
R3 (03h)	13	LON_ENA (rw)	0b	LON Line Out and LONMIX Enable 0 = disabled 1 = enabled
	12	LOP_ENA (rw)	0b	LOP Line Out and LOPMIX Enable 0 = disabled 1 = enabled
	11	RON_ENA (rw)	0b	RON Line Out and RONMIX Enable 0 = disabled 1 = enabled
	10	ROP_ENA (rw)	0b	ROP Line Out and ROPMIX Enable 0 = disabled 1 = enabled
	8	SPKPGA_ENA (rw)	0b	SPKMIX Mixer and Speaker PGA Enable 0 = disabled 1 = enabled Note that SPKMIX and SPKPGA are also enabled when SPK_ENA is set.
	7	LOPGA_ENA (rw)	0b	LOPGA Left Volume Control Enable 0 = disabled 1 = enabled
	6	ROPGA_ENA (rw)	0b	ROPGA Right Volume Control Enable 0 = disabled 1 = enabled
	5	LOMIX_ENA (rw)	0b	LOMIX Left Output Mixer Enable 0 = disabled 1 = enabled
	4	ROMIX_ENA (rw)	0b	ROMIX Right Output Mixer Enable 0 = disabled 1 = enabled
	1	DACL_ENA (rw)	0b	Left DAC Enable 0 = disabled 1 = enabled

REGISTER ADDRESS	BIT	LABEL	DEFAULT	DESCRIPTION
	0	DACR_ENA (rw)	0b	Right DAC Enable 0 = disabled 1 = enabled

Table 79 Power Management

CHIP RESET AND ID

The device ID can be read back from register 0. Writing to this register will reset the device.

REGISTER ADDRESS	BIT	LABEL	DEFAULT	DESCRIPTION
R0 (00h) Reset / ID	15:0	SW_RESET_ CHIP_ID [15:0] (rr)	8990h	Writing to this register resets all registers to their default state. Reading from this register will indicate device family ID 8990h.

Table 80 Chip Reset and ID

SAVING POWER AT HIGHER SUPPLY VOLTAGE

The AVDD supply of the WM8991 can operate between 2.7V and 3.6V. By default, all analogue circuitry on the device is optimized to run at 3.3V. This set-up is also good for all other supply voltages down to 2.7V. At lower voltages, performance can be improved by increasing the bias current. If low power operation is preferred the bias current can be left at the default setting. This is controlled as shown in Table 81.

REGISTER ADDRESS	BIT	LABEL	DEFAULT	DESCRIPTION
R51 (33h)	8:7	VSEL [1:0]	11	Analogue Bias Optimisation 00 = Reserved 01 = Bias current optimized for AVDD=2.7V 1X = Bias current optimized for AVDD=3.3V

Table 81 Bias Optimisation

POP SUPPRESSION CONTROL

In normal operation, the analogue circuits in the WM8991 are referenced to VMID (AVDD/2). When this reference voltage is first enabled, it will ramp quickly from AGND to AVDD/2 and, if connected to an active output, will result in an audible pop being heard. Enabling or disabling the output stage after the internal reference has settled can also result in an audible pop as the output rises rapidly from AGND.

The WM8991 provides a number of features which enable these pops to be suppressed. The associated control bits are described in this section. Careful attention is required to the sequence and timing of these controls in order to get maximum benefit. An outline of some generic control sequences is provided in order to assist users in the definition of application-specific sequences.

REFERENCE VOLTAGES

VMID is generated from AVDD via a programmable resistor chain as shown in the audio signal paths diagram on page 28. Together with the external decoupling capacitor on VMID, the programmable resistor chain results in a slow, normal or fast charging characteristic on VMID. The VMID reference is controlled by VMID_MODE[1:0].

The analogue circuits in the WM8991 require a bias current. The default bias current is enabled by setting VREF_ENA. Note that the default bias current source requires VMID to be enabled also.

REGISTER ADDRESS	BIT	LABEL	DEFAULT	DESCRIPTION
R1 (01h)	2:1	VMID_MODE [1:0] (rw)	00b	VMID Divider Enable and Select 00 = VMID disabled (for OFF mode) 01 = 2 x 50kΩ divider (Normal mode) 10 = 2 x 250kΩ divider (Standby mode) 11 = 2 x 5kΩ divider (for fast start-up)
	0	VREF_ENA (rw)	0b	VREF Enable (Bias for all analogue functions) 0 = VREF bias disabled 1 = VREF bias enabled

Table 82 Reference Voltages

SOFT START CONTROL

A pop-suppressed start-up requires VMID to be enabled smoothly, without the step change normally associated with the initial stage of the VMID capacitor charging. A pop-suppressed start-up also requires the analogue bias current to be enabled throughout the signal path prior to the VMID reference voltage being applied. The WM8991 incorporates pop-suppression circuits which address these requirements.

The WM8991 provides an alternative start-up bias circuit which can be used in place of the default bias current during start-up. The start-up bias current source is enabled by BUFDCOPEN. The start-up bias source is selected (in place of the default bias source) by POBCTRL. It is recommended that the start-up bias is used during start-up, before switching back to the higher quality, VREF-enabled bias.

A soft-start circuit is provided in order to control the switch-on of the VMID reference. The soft-start control circuit is enabled by setting SOFTST. When the soft-start circuit is enabled prior to enabling VMID_MODE, the reference voltage rises smoothly, without the step change that would otherwise occur. It is recommended that the soft-start circuit and the output signal path be enabled before VMID is enabled by VMID_MODE.

Soft shut-down of VMID is also provided by the soft-start control circuit and the start-up bias current generator. The soft shut-down of VMID is achieved by setting SOFTST = 1, BUFDCOPEN = 1 and POBCTRL = 1 prior to setting VMID_MODE = 00.

The register fields associated with soft start control are described in Table 83.

REGISTER ADDRESS	BIT	LABEL	DEFAULT	DESCRIPTION
R57 (39h) Anti-Pop (2)	6	SOFTST	0b	Enables VMID soft start 0 = Disabled 1 = Enabled
	2	BUFDOPEN	0b	Enables the Start-Up bias current generator 0 = Disabled 1 = Enabled
	1	POBCTRL	0b	Selects the bias current source for output amplifiers and VMID buffer 0 = Default bias 1 = Start-Up bias

Table 83 Soft Start Control

DISABLED INPUT/OUTPUT CONTROL

After start-up, it may be desirable to disable an output stage, in order to reduce power consumption on an unused output. In order to avoid audible pops caused by a disabled output dropping to AGND, the WM8991 can maintain the output at VMID even when the output driver is disabled. This is achieved by connecting a buffered VMID reference to the output. The buffered VMID is enabled by setting BUFIOEN. When BUFIOEN is enabled, it will be connected to any disabled output driver. It is recommended that BUFIOEN is enabled prior to disabling the output driver.

The buffered VMID, enabled by BUFIOEN, also maintains the charge on the input capacitors connected to any disabled input amplifier. Buffered VMID is connected to each input through 1k Ω resistors. This suppresses the audible artefacts that would otherwise arise when an input amplifier is disabled or enabled. In some applications, a pop generated at an input stage can be entirely suppressed by correctly managing the output stages. However, it may be desirable to use the buffered VMID feature in order to eliminate the input PGA start-up delay (the input capacitor charging time) in addition to suppressing any mute/un-mute pops. In applications where frequent enabling and configuration of signal paths is used, it is recommended to enable BUFIOEN at all times.

REGISTER ADDRESS	BIT	LABEL	DEFAULT	DESCRIPTION
R57 (39h) Anti-Pop (2)	3	BUFIOEN	0b	Enables the Buffered VMID reference at disabled inputs/outputs 0 = Disabled 1 = Enabled

Table 84 Disabled Input/Output Control

OUTPUT DISCHARGE CONTROL

The output paths may also be actively discharged to AGND through internal resistors if desired. This is desirable at start-up in order to achieve a known output stage condition prior to enabling the soft-start VMID reference voltage. This is also desirable in shut-down in order to eliminate pops arising from memory effects in the output capacitors on completion of the controlled shut-down of the VMID reference. Note that, for any signal paths that do not use output capacitors (eg. capless headphone drive), the discharge control is not normally required.

It is recommended that the output paths should be actively discharged prior to commencing a start-up sequence. The active discharging should then be disabled prior to enabling the output drivers.

In shut-down, it is recommended that the output paths should be actively discharged after the VMID reference has settled to AGND and the output drivers have been disabled.

The line and headphone output pins are discharged by setting DIS_LLINE, DIS_RLINE, DIS_OUT3, DIS_OUT4, DIS_LOUT and DIS_ROUT, as described in Table 85. Note that the buffered VMID reference is not applied to an actively discharged output, regardless of BUFIOEN.

REGISTER ADDRESS	BIT	LABEL	DEFAULT	DESCRIPTION
R56 (38h) Anti-Pop (1)	5	DIS_LLLINE	0b	Discharges LOP and LON outputs via approx 500Ω resistor 0 = Not active 1 = Actively discharging LOP and LON
	4	DIS_RLINE	0b	Discharges ROP and RON outputs via approx 500Ω resistor 0 = Not active 1 = Actively discharging ROP and RON
	3	DIS_OUT3	0b	Discharges OUT3 output via approx 500Ω resistor 0 = Not active 1 = Actively discharging OUT3
	2	DIS_OUT4	0b	Discharges OUT4 output via approx 500Ω resistor 0 = Not active 1 = Actively discharging OUT4
	1	DIS_LOUT	0b	Discharges LOUOUT output via approx 500Ω resistor 0 = Not active 1 = Actively discharging LOUOUT
	0	DIS_ROUT	0b	Discharges ROUT output via approx 500Ω resistor 0 = Not active 1 = Actively discharging ROUT

Table 85 Output Discharge Control

VMID REFERENCE DISCHARGE CONTROL

The VMID reference can be discharged to AGND through internal resistors. Discharging VMID ensures that a subsequent start-up procedure commences with a known voltage condition; this is necessary in order to ensure maximum suppression of audible pops associated with start-up. VMID is discharged by setting VMIDTOG, as described in Table 86.

REGISTER ADDRESS	BIT	LABEL	DEFAULT	DESCRIPTION
R57 (39h) Anti-Pop (2)	0	VMIDTOG	0b	Connects VMID to ground 0 = Disabled 1 = Enabled

Table 86 VMID Reference Discharge Control

EXAMPLE CONTROL SEQUENCES

Pop-suppression control sequences are described below for typical WM8991 operations involving start-up, muting and disabling of signal paths. Note that these descriptions are intended for guidance only. Application software should be verified and tailored to ensure optimum performance.

Start-up sequence

The following sequence describes the register settings required to enable the headphone outputs LOUT and ROUT. It assumes that VMID and VREF are initially disabled and actively discharged to AGND.

STEP	DESCRIPTION	REGISTER SETTING
1	Discharge output drivers.	DIS_LOUT = 1 DIS_ROUT = 1
2	Time delay for output capacitors to discharge.	
3	Enable soft start control and start-up bias source. Select start-up bias.	SOFTST = 1 BUFCOPEN = 1 POBCTRL = 1
4	Disable active discharging of VMID and Output drivers.	VMIDTOG = 0 DIS_LOUT = 0 DIS_ROUT = 0
5	Enable Output drivers.	LOUT_ENA = 1 ROUT_ENA = 1
6	Enable VMID and VREF.	VMID_MODE = 01 VREF_ENA = 1
7	Time delay for soft-start to execute	
8	Select default bias source.	POBCTRL = 0
9	Disable soft start control and soft start voltage.	SOFTST = 0 BUFCOPEN = 0

Table 87 Example Start-Up Control SequenceOutput Mute sequence

The following sequence describes the register settings required to mute and disable the headphone outputs LOUT and ROUT. It assumes that the soft start bias voltage is initially disabled.

STEP	DESCRIPTION	REGISTER SETTING
1	Enable buffered VMID at all input and output circuits.	BUFIOEN = 1
2	Disable output drivers	LOUT_ENA = 0 ROUT_ENA = 0

Table 88 Example Mute Control SequenceOutput Un-Mute sequence

The following sequence describes the register settings required to enable and un-mute the headphone outputs LOUT and ROUT.

STEP	DESCRIPTION	REGISTER SETTING
1	Enable Output drivers.	LOUT_ENA = 1 ROUT_ENA = 1
2	Disable buffered VMID at all input and output circuits.	BUFIOEN = 0

Table 89 Example Un-Mute Control Sequence

Shut-down and discharge sequence

The following sequence describes the register settings required to mute, disable and discharge the headphone outputs LOUT and ROUT. It assumes that the soft start control and voltage source is already disabled.

STEP	DESCRIPTION	REGISTER SETTING
1	Enable soft start control and start-up bias source. Select start-up bias.	SOFTST = 1 BUFCOPEN = 1 POBCTRL = 1
2	Disable VMID	VMID_MODE = 00
3	Time delay for soft-shutdown to execute	
4	Disable Output drivers.	LOUT_ENA = 0 ROUT_ENA = 0
5	Discharge output drivers.	DIS_LOUT = 1 DIS_ROUT = 1
6	Select default bias source.	POBCTRL = 0
7	Disable soft start control and soft start voltage.	SOFTST = 0 BUFCOPEN = 0

Table 90 Example Shut-down and Discharge Control Sequence

POWER DOMAINS

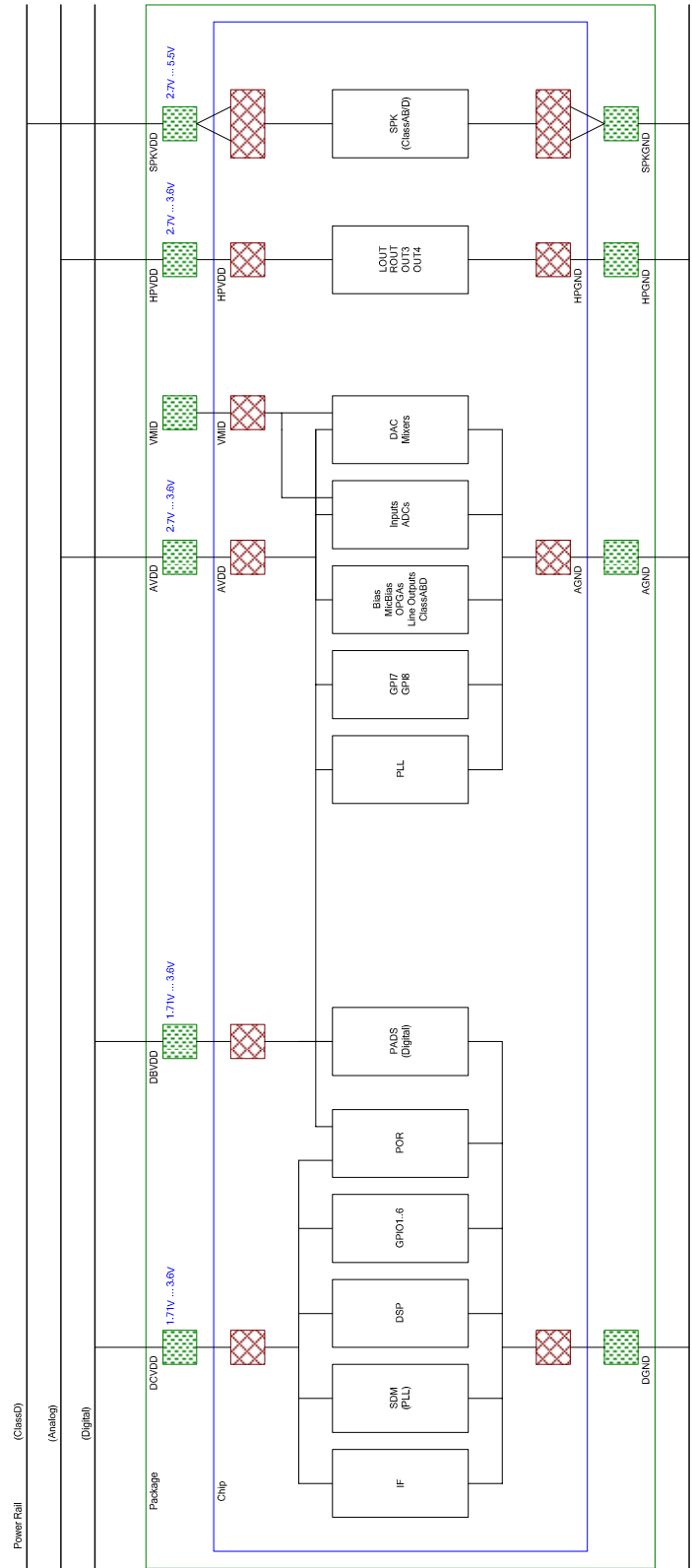

Figure 89 WM8991 Power Domains

REGISTER MAP

Dec Addr	Hex Addr	Name	15	14	13	12	11	10	9	8	7	6	5	4	3	2	1	0	Bin Default
0	0	Reset																	1000_1001_1001_0000
1	1	Power Management (1)	0	0	0	SPK_ENA	OUT3_ENA	OUT4_ENA	LOUT_ENA	ROUT_ENA	0	0	0	0	MICBIAS_ENA	0	VIMD_MODEE[0]	VREF_ENA	0000_0000_0000_0000
2	2	Power Management (2)	PLL_ENA	TSHUT_ENA	TSHUT_OPD[5]	0	OPCLK_ENA	0	AINL_ENA	AINR_ENA	LIN34_ENA	LIN12_ENA	RIN34_ENA	RIN12_ENA	0	0	ADCL_ENA	ADCR_ENA	0110_0000_0000_0000
3	3	Power Management (3)	0	0	LON_ENA	LOP_ENA	RON_ENA	ROP_ENA	0	SPAPCA	LOPGA_ENA	ROPGA_ENA	LOMIX_ENA	ROMIX_ENA	0	0	DACL_ENA	DACR_ENA	0000_0000_0000_0000
4	4	Audio Interface (1)	AIFADCL_SRC	AIFADCR_SRC	AIFADCL_SRC	AIFADCL_SRC	AIFADCR_SRC	AIFADCL_SRC	AIFADCR_SRC	AIFADCL_SRC	AIFADCR_SRC	AIFADCL_SRC	AIFADCR_SRC	AIFADCL_SRC	AIFADCR_SRC	0	0	0	0100_0000_0101_0000
5	5	Audio Interface (2)	DACL_SRC	DACR_SRC	AIFADCL_SRC	AIFADCL_SRC	AIFADCR_SRC	AIFADCL_SRC	AIFADCR_SRC	0	0	0	0	0	DAAC_COMP	DAAC_COMP	ADAC_COMP	LOOPBACK	0100_0000_0000_0000
6	6	Clocking (1)	TOCLK_RATE	TOCLK_ENA	0	0	0	0	0	0	0	0	0	0	0	0	0	0	0000_0001_1100_0000
7	7	Clocking (2)	MCLK_SRC	SYCLK_SRC	CLK_FORCE	MCLK_FORCE	MCLK_INV[1:0]	0	0	0	0	0	0	0	0	0	0	0	0000_0000_0000_0000
8	8	Audio Interface (3)	AIF_MSTR1	AIF_MSTR2	AIF_SEL	0	ADCLRC_DIR	0	0	0	0	0	0	0	0	0	0	0	0000_0000_0000_0000
9	9	Audio Interface (4)	ALRCGP1OT	ALRCGP1OB	AIF_TRIS	0	DACLRC_DIR	0	0	0	0	0	0	0	0	0	0	0	0000_0000_0100_0000
10	A	DAC CTRL	0	0	0	0	0	0	0	0	0	0	0	0	0	0	0	0	0000_0000_0100_0100
11	B	Left DAC Digital Volume	0	0	0	0	0	0	0	0	0	0	0	0	0	0	0	0	0000_0000_1100_0000
12	C	Right DAC Digital Volume	0	0	0	0	0	0	0	0	0	0	0	0	0	0	0	0	0000_0000_1100_0000
13	D	Digital Side Tone	0	0	0	0	0	0	0	0	0	0	0	0	0	0	0	0	0000_0000_0000_0000
14	E	ADC CTRL	0	0	0	0	0	0	0	0	0	0	0	0	0	0	0	0	0000_0001_0000_0000
15	F	Left ADC Digital Volume	0	0	0	0	0	0	0	0	0	0	0	0	0	0	0	0	0000_0000_1100_0000
16	10	Right ADC Digital Volume	0	0	0	0	0	0	0	0	0	0	0	0	0	0	0	0	0000_0000_1100_0000
17	11	Reserved	0	0	0	0	0	0	0	0	0	0	0	0	0	0	0	0	0000_0000_0000_0000
18	12	GPIO CTRL 1	0	0	0	0	0	0	0	0	0	0	0	0	0	0	0	0	0000_PPP_PPP_PPP_PPP
19	13	GPIO1 & GPIO2	GPIO2_DEB_ENA	GPIO2_IRQ_ENA	GPIO2_IRQ_ENA	GPIO2_PD	GPIO2_SEL[3:0]	GPIO2_SEL[3:0]	GPIO2_SEL[3:0]	GPIO2_SEL[3:0]	GPIO1_DEB_ENA	GPIO1_IRQ_ENA	GPIO1_PD	GPIO1_SEL[3:0]	GPIO1_SEL[3:0]	GPIO1_SEL[3:0]	GPIO1_SEL[3:0]	GPIO1_SEL[3:0]	0001_0000_0000_0000
20	14	GPIO3 & GPIO4	GPIO4_DEB_ENA	GPIO4_IRQ_ENA	GPIO4_IRQ_ENA	GPIO4_PD	GPIO4_SEL[3:0]	GPIO4_SEL[3:0]	GPIO4_SEL[3:0]	GPIO4_SEL[3:0]	GPIO3_DEB_ENA	GPIO3_IRQ_ENA	GPIO3_PD	GPIO3_SEL[3:0]	GPIO3_SEL[3:0]	GPIO3_SEL[3:0]	GPIO3_SEL[3:0]	GPIO3_SEL[3:0]	0001_0000_0001_0000
21	15	GPIO5 & GPIO6	GPIO5_DEB_ENA	GPIO5_IRQ_ENA	GPIO5_IRQ_ENA	GPIO5_PD	GPIO5_SEL[3:0]	GPIO5_SEL[3:0]	GPIO5_SEL[3:0]	GPIO5_SEL[3:0]	GPIO5_DEB_ENA	GPIO5_IRQ_ENA	GPIO5_PD	GPIO5_SEL[3:0]	GPIO5_SEL[3:0]	GPIO5_SEL[3:0]	GPIO5_SEL[3:0]	GPIO5_SEL[3:0]	0001_0000_0001_0000
22	16	GPIOCTRL 2	RD_3W_ENA	MODE_3WAY	0	0	0	0	0	0	0	0	0	0	0	0	0	0	1000_0000_0000_0000
23	17	GPIO_POL	0	0	0	0	0	0	0	0	0	0	0	0	0	0	0	0	0000_1000_0000_0000
24	18	Left Line Input 1&2 Volume	0	0	0	0	0	0	0	0	0	0	0	0	0	0	0	0	0000_0000_1000_0111
25	19	Left Line Input 3&4 Volume	0	0	0	0	0	0	0	0	0	0	0	0	0	0	0	0	0000_0000_1000_0111
26	1A	Right Line Input 1&2 Volume	0	0	0	0	0	0	0	0	0	0	0	0	0	0	0	0	0000_0000_1000_0111
27	1B	Right Line Input 3&4 Volume	0	0	0	0	0	0	0	0	0	0	0	0	0	0	0	0	0000_0000_1000_0111
28	1C	Left Output Volume	0	0	0	0	0	0	0	0	0	0	0	0	0	0	0	0	0000_0000_0000_0000
29	1D	Right Output Volume	0	0	0	0	0	0	0	0	0	0	0	0	0	0	0	0	0000_0000_0000_0000
30	1E	Line Outputs Volume	0	0	0	0	0	0	0	0	0	0	0	0	0	0	0	0	0000_0000_0110_0110
31	1F	Out3&4 Volume	0	0	0	0	0	0	0	0	0	0	0	0	0	0	0	0	0000_0000_0010_0010

Dec Addr	Hex Addr	Name	15	14	13	12	11	10	9	8	7	6	5	4	3	2	1	0	Bin Default
32	20	Left OFGA Volume	0	0	0	0	0	0	0	OPVU[2]	LOPGAZC				LOPGAVAL[6:0]			0	0000_000p_0111_0001
33	21	Right OFGA Volume	0	0	0	0	0	0	0	OPVU[3]	ROPGAZC				ROPGAVAL[6:0]			0	0000_000p_0111_0001
34	22	Speaker Volume	0	0	0	0	0	0	0	0	0	0	0	0	0	0	0	0	0000_0000_0000_0011
35	23	ClassD1	0	0	0	0	0	0	0	CDMODE	0	0	0	0	0	0	0	1	0000_0000_0000_0011
36	24	ClassD2	0	0	0	0	0	0	0	0	0	1	0	0	0	0	0	1	0000_0000_0101_0101
37	25	ClassD3	0	0	0	0	0	0	0	1	0	0	0	0	DCGAN[2:0]	ACGAN[2:0]		0	0000_0001_0000_0000
38	26	ClassD4	0	0	0	0	0	0	0	0	SPKZC				SPKVAL[6:0]			0	0000_0000_0111_0001
39	27	Input Mixer1	0	0	0	0	0	0	0	0	0	0	0	0	AINLMODE[1:0]	AINRMODE[1:0]		0	0000_0000_0000_0000
40	28	Input Mixer2	0	0	0	0	0	0	0	0	LMR4	LMN3	LMP2	LMN1	RMP4	RMN3	RMP2	RMN1	0000_0000_0000_0000
41	29	Input Mixer3	0	0	0	0	0	0	0	L34MNB	L34MNBST	0	L12MNB	L12MNBST	0	LDBYVAL[2:0]	0	0	0000_0000_0000_0000
42	2A	Input Mixer4	0	0	0	0	0	0	0	R34MNB	R34MNBST	0	R12MNB	R12MNBST	0	RBSVAL[2:0]	0	0	0000_0000_0000_0000
43	2B	Input Mixer5	0	0	0	0	0	0	0	L2BVAL[2:0]	L2BVAL[2:0]			L4B4VAL[2:0]	LL4B4VAL[2:0]			0000_0000_0000_0000	
44	2C	Input Mixer6	0	0	0	0	0	0	0	R2BVAL[2:0]	R2BVAL[2:0]			RL4B4VAL[2:0]	RR4B4VAL[2:0]			0000_0000_0000_0000	
45	2D	Output Mixer1	0	0	0	0	0	0	0	0	LRLO	LLBO	LRLO	LLBO	LR12LO	LL12LO	0	LDLO	0000_0000_0000_0000
46	2E	Output Mixer2	0	0	0	0	0	0	0	0	RLRO	RRRO	RL3RO	RR3RO	RL12RO	RR12RO	0	RDRO	0000_0000_0000_0000
47	2F	Output Mixer3	0	0	0	0	0	0	0	0	LL3LOVAL[2:0]	LL3LOVAL[2:0]			LR12LOVAL[2:0]	LL12LOVAL[2:0]			0000_0000_0000_0000
48	30	Output Mixer4	0	0	0	0	0	0	0	0	RR3ROVAL[2:0]	RR3ROVAL[2:0]			RL12ROVAL[2:0]	RR12ROVAL[2:0]			0000_0000_0000_0000
49	31	Output Mixer5	0	0	0	0	0	0	0	0	LR3LOVAL[2:0]	LR3LOVAL[2:0]			LRBLOVAL[2:0]	LLBLOVAL[2:0]			0000_0000_0000_0000
50	32	Output Mixer6	0	0	0	0	0	0	0	0	RL3ROVAL[2:0]	RL3ROVAL[2:0]			RLBROVAL[2:0]	RRBROVAL[2:0]			0000_0000_0000_0000
51	33	Out34 Mixer	0	0	0	0	0	0	0	VSEL[1:0]	0	LH03	LPGA03	0	0	RHO4	RFGA04		0000_0001_1000_0000
52	34	Line Mixer1	0	0	0	0	0	0	0	0	0	LLOFGALON	LLOFGALON	0	0	LR12LOP	LLOFGALOP		0000_0000_0000_0000
53	35	Line Mixer2	0	0	0	0	0	0	0	0	0	RROFGARON	RROFGARON	0	0	RL12ROP	RROFGAROP		0000_0000_0000_0000
54	36	Speaker Mixer	0	0	0	0	0	0	0	0	LB2SPK	RB2SPK	LBSPK	RBSPK	LOFGASPK	LBSPK	RBSPK		0000_0000_0000_0000
55	37	Additional Control	0	0	0	0	0	0	0	0	0	0	0	0	0	0	0	VROI	0000_0000_0000_0000
56	38	AntiPOP1	0	0	0	0	0	0	0	0	0	0	0	DIS_LINE	DIS_OUT3	DIS_OUT4	DIS_OUT	DIS_FOUT	0000_0000_0000_0000
57	39	AntiPOP2	0	0	0	0	0	0	0	0	0	SOFTST	0	0	BUFOEN	BUFGCOEN	POBCTRL	VMDTOG	0000_0000_0000_0000
58	3A	MICBIAS	0	0	0	0	0	0	0	0	MCDSTH[1:0]	MCDTHR[2:0]	0	0	MCD	0	MBSSEL	0000_0000_0000_0000	
59	3B	Reserved	0	0	0	0	0	0	0	0	0	0	0	0	0	0	0	0	0000_0000_0000_0000
60	3C	PLL1	0	0	0	0	0	0	0	0	SDM	PRESCALE	0	0	0	0	0	0	0000_0000_0000_0000
61	3D	PLL2	0	0	0	0	0	0	0	0	0	0	0	0	0	0	0	0	0000_0000_0111_0001
62	3E	PLL3	0	0	0	0	0	0	0	0	0	0	0	0	0	0	0	0	0000_0000_0000_0110
63	3F	Reserved	0	0	0	0	0	0	0	0	0	0	0	0	0	0	0	0	0000_0000_0000_0000

Note:

A bin default value of 'p' indicates a register field where a default value is not applicable e.g. a volume update bit.

REGISTER BITS BY ADDRESS

REGISTER ADDRESS	BIT	LABEL	DEFAULT	DESCRIPTION
R0 (00h) Reset / ID	15:0	SW_RESET_CHIP_ID [15:0] (rr)	8990h	Writing to this register resets all registers to their default state. Reading from this register will indicate device family ID 8990h.
R1 (01h) Power Management (1)	15:13		000b	Reserved - Do Not Change
	12	SPK_ENA (rw)	0b	SPKMIX Mixer, Speaker PGA and Speaker Output Enable 0 = disabled 1 = enabled
	11	OUT3_ENA (rw)	0b	OUT3 and OUT3MIX Enable 0 = disabled 1 = enabled
	10	OUT4_ENA (rw)	0b	OUT4 and OUT4MIX Enable 0 = disabled 1 = enabled
	9	LOUT_ENA (rw)	0b	LOUT (Left Headphone Output) Enable 0 = disabled 1 = enabled
	8	ROUT_ENA (rw)	0b	ROUT (Right Headphone Output) Enable 0 = disabled 1 = enabled
	7:5		000b	Reserved - Do Not Change
	4	MICBIAS_ENA (rw)	0b	MICBIAS Enable 0 = OFF (high impedance output) 1 = ON
	3		0b	Reserved - Do Not Change
	2:1	VMID_MODE [1:0] (rw)	00b	Vmid Divider Enable and Select 00 = Vmid disabled (for OFF mode) 01 = 2 x 50kΩ divider (Normal mode) 10 = 2 x 250kΩ divider (Standby mode) 11 = 2 x 5kΩ divider (for fast start-up)
0	VREF_ENA (rw)	0b	VREF Enable (Bias for all analogue functions) 0 = VREF bias disabled 1 = VREF bias enabled	
R02 (02h) Power Management (2)	15	PLL_ENA (rw)	0b	PLL Enable 0 = disabled 1 = enabled
	14	TSHUT_ENA (rw)	1b	Thermal Sensor Enable 0 = Thermal sensor disabled 1 = Thermal sensor enabled
	13	TSHUT_OPDIS (rw)	1b	Thermal Shutdown Enable (Requires thermal sensor to be enabled) 0 = Thermal shutdown disabled 1 = Thermal shutdown enabled
	12		0b	Reserved - Do Not Change
	11	OPCLK_ENA (rw)	0b	GPIO Clock Output Enable 0 = disabled 1 = enabled
	10		0b	Reserved - Do Not Change

REGISTER ADDRESS	BIT	LABEL	DEFAULT	DESCRIPTION
	9	AINL_ENA (rw)	0b	Left Input Path Enable (Enables AINLMUX, INMIXL, DIFFINL and RXVOICE input to AINLMUX) 0 = disabled 1 = enabled
	8	AINR_ENA (rw)	0b	Right Input Path Enable (Enables AINRMUX, INMIXR, DIFFINR and RXVOICE input to AINRMUX) 0 = disabled 1 = enabled
	7	LIN34_ENA (rw)	0b	LIN34 Input PGA Enable 0 = disabled 1 = enabled
	6	LIN12_ENA (rw)	0b	LIN12 Input PGA Enable 0 = disabled 1 = enabled
	5	RIN34_ENA (rw)	0b	RIN34 Input PGA Enable 0 = disabled 1 = enabled
	4	RIN12_ENA (rw)	0b	RIN12 Input PGA Enable 0 = disabled 1 = enabled
	3:2		00b	Reserved - Do Not Change
	1	ADCL_ENA (rw)	0b	Left ADC Enable 0 = disabled 1 = enabled
	0	ADCR_ENA (rw)	0b	Right ADC Enable 0 = disabled 1 = enabled
R03 (03h) Power Management (3)	15:14		00b	Reserved - Do Not Change
	13	LON_ENA (rw)	0b	LON Line Out and LONMIX Enable 0 = disabled 1 = enabled
	12	LOP_ENA (rw)	0b	LOP Line Out and LOPMIX Enable 0 = disabled 1 = enabled
	11	RON_ENA (rw)	0b	RON Line Out and RONMIX Enable 0 = disabled 1 = enabled
	10	ROP_ENA (rw)	0b	ROP Line Out and ROPMIX Enable 0 = disabled 1 = enabled
	9		0b	Reserved - Do Not Change
	8	SPKPGA_ENA (rw)	0b	SPKMIX Mixer and Speaker PGA Enable 0 = disabled 1 = enabled Note that SPKMIX and SPKPGA are also enabled when SPK_ENA is set.
	7	LOPGA_ENA (rw)	0b	LOPGA Left Volume Control Enable 0 = disabled 1 = enabled
	6	ROPGA_ENA (rw)	0b	ROPGA Right Volume Control Enable 0 = disabled 1 = enabled

REGISTER ADDRESS	BIT	LABEL	DEFAULT	DESCRIPTION
	5	LOMIX_ENA (rw)	0b	LOMIX Left Output Mixer Enable 0 = disabled 1 = enabled
	4	ROMIX_ENA (rw)	0b	ROMIX Right Output Mixer Enable 0 = disabled 1 = enabled
	3:2		00b	Reserved - Do Not Change
	1	DACL_ENA (rw)	0b	Left DAC Enable 0 = disabled 1 = enabled
	0	DACR_ENA (rw)	0b	Right DAC Enable 0 = disabled 1 = enabled
R04 (04h) Audio Interface (1)	15	AIFADCL_SRC	0b	Left Digital Audio channel source 0 = Left ADC data is output on left channel 1 = Right ADC data is output on left channel
	14	AIFADCR_SRC	1b	Right Digital Audio channel source 0 = Left ADC data is output on right channel 1 = Right ADC data is output on right channel
	13	AIFADC_TDM	0b	ADC TDM Enable 0 = Normal ADCDAT operation 1 = TDM enabled on ADCDAT
	12	AIFADC_TDM_CHAN	0b	ADCDAT TDM Channel Select 0 = ADCDAT outputs data on slot 0 1 = ADCDAT output data on slot 1
	11:9		0b	Reserved - Do Not Change
	8	AIF_BCLK_INV	0b	BCLK Invert 0 = BCLK not inverted 1 = BCLK inverted
	7	AIF_LRCLK_INV	0b	Right, left and I ² S modes – LRCLK polarity 0 = normal LRCLK polarity 1 = invert LRCLK polarity DSP Mode – mode A/B select 0 = MSB is available on 2nd BCLK rising edge after LRC rising edge (mode A) 1 = MSB is available on 1st BCLK rising edge after LRC rising edge (mode B)
	6:5	AIF_WL [1:0]	10b	Digital Audio Interface Word Length 00 = 16 bits 01 = 20 bits 10 = 24 bits 11 = 32 bits
	4:3	AIF_FMT [1:0]	10b	Digital Audio Interface Format 00 = Right justified 01 = Left justified 10 = I ² S Format 11 = DSP Mode
	2:0		0b	Reserved - Do Not Change
R05 (05h) Audio Interface (2)	15	DACL_SRC	0b	Left DAC Data Source Select 0 = Left DAC outputs left channel data 1 = Left DAC outputs right channel data
	14	DACR_SRC	1b	Right DAC Data Source Select 0 = Right DAC outputs left channel data 1 = Right DAC outputs right channel data

REGISTER ADDRESS	BIT	LABEL	DEFAULT	DESCRIPTION
	13	AIFDAC_TDM	0b	DAC TDM Enable 0 = Normal DACDAT operation 1 = TDM enabled on DACDAT
	12	AIFDAC_TDM_CHAN	0b	DACDAT TDM Channel Select 0 = DACDAT data input on slot 0 1 = DACDAT data input on slot 1
	11:10	DAC_BOOST [1:0]	00b	DAC Input Volume Boost 00 = 0dB 01 = +6dB (Input data must not exceed -6dBFS) 10 = +12dB (Input data must not exceed -12dBFS) 11 = +18dB (Input data must not exceed -18dBFS)
	9:5			Reserved - Do Not Change
	4	DAC_COMP	0b	DAC Companding Enable 0 = disabled 1 = enabled
	3	DAC_COMPMODE	0b	DAC Companding Type 0 = μ -law 1 = A-law
	2	ADC_COMP	0b	ADC Companding Enable 0 = disabled 1 = enabled
	1	ADC_COMPMODE	0b	ADC Companding Type 0 = μ -law 1 = A-law
	0	LOOPBACK	0b	Digital Loopback Function 0 = No loopback 1 = Loopback enabled (ADC data output is directly input to DAC data input). Note: ADC and DAC left/right clocks must be set to the same pin when using LOOPBACK function (ALRCGPIO1=1)
R06 (06h) Clocking (1)	15	TOCLK_RATE	0b	Timeout Clock Rate (Selects clock to be used for volume update timeout and GPIO input de-bounce) 0 = SYSCLK / 2 ²¹ (Slower Response) 1 = SYSCLK / 2 ¹⁹ (Faster Response)
	14	TOCLK_ENA	0b	Timeout Clock Enable (This clock is required for volume update timeout and GPIO input de-bounce) 0 = disabled 1 = enabled
	13			Reserved - Do Not Change
	12:9	OPCLKDIV [3:0]	0000b	GPIO Output Clock Divider 0000 = SYSCLK 0001 = SYSCLK / 2 0010 = SYSCLK / 3 0011 = SYSCLK / 4 0100 = SYSCLK / 5.5 0101 = SYSCLK / 6 0110 = SYSCLK / 8 0111 = SYSCLK / 12 1000 = SYSCLK / 16 1001 to 1111 = Reserved

REGISTER ADDRESS	BIT	LABEL	DEFAULT	DESCRIPTION
	8:6	DCLKDIV [2:0]	111b	Class D Clock Divider 000 = SYSCLK 001 = SYSCLK / 2 010 = SYSCLK / 3 011 = SYSCLK / 4 100 = SYSCLK / 6 101 = SYSCLK / 8 110 = SYSCLK / 12 111 = SYSCLK / 16
	5		0b	Reserved - Do Not Change
	4:1	BCLK_DIV [3:0]	0100b	BCLK Frequency (Master Mode) 0000 = SYSCLK 0001 = SYSCLK / 1.5 0010 = SYSCLK / 2 0011 = SYSCLK / 3 0100 = SYSCLK / 4 0101 = SYSCLK / 5.5 0110 = SYSCLK / 6 0111 = SYSCLK / 8 1000 = SYSCLK / 11 1001 = SYSCLK / 12 1010 = SYSCLK / 16 1011 = SYSCLK / 22 1100 = SYSCLK / 24 1101 = SYSCLK / 32 1110 = SYSCLK / 44 1111 = SYSCLK / 48
	0		0b	Reserved - Do Not Change
R07 (07h) Clocking (2)	15	MCLK_SRC	0b	MCLK Source Select 0 = MCLK pin 1 = GPIO2/MCLK2 pin
	14	SYSCLK_SRC	0b	SYSCLK Source Select 0 = MCLK (or MCLK2 if MCLK_SRC=1) 1 = PLL output
	13	CLK_FORCE	0b	Forces Clock Source Selection 0 = Existing SYSCLK source (MCLK, MCLK2 or PLL output) must be active when changing to a new clock source. 1 = Allows existing MCLK source to be disabled before changing to a new clock source.
	12:11	MCLK_DIV [1:0]	00b	SYSCLK Pre-divider. Clock source (MCLK, MCLK2 or PLL output) will be divided by this value to generate SYSCLK. 00 = Divide SYSCLK by 1 01 = Reserved 10 = Divide SYSCLK by 2 11 = Reserved
	10	MCLK_INV	0b	MCLK Invert 0 = Master clock (MCLK or MCLK2) not inverted 1 = Master clock (MCLK or MCLK2) inverted
	9:8		00b	Reserved - Do Not Change

REGISTER ADDRESS	BIT	LABEL	DEFAULT	DESCRIPTION
	7:5	ADC_CLKDIV [2:0]	000b	ADC Sample Rate Divider 000 = SYSCLK / 1.0 001 = SYSCLK / 1.5 010 = SYSCLK / 2.0 011 = SYSCLK / 3.0 100 = SYSCLK / 4.0 101 = SYSCLK / 5.5 110 = SYSCLK / 6.0 111= Reserved
	4:2	DAC_CLKDIV [2:0]	000b	DAC Sample Rate Divider 000 = SYSCLK / 1.0 001 = SYSCLK / 1.5 010 = SYSCLK / 2.0 011 = SYSCLK / 3.0 100 = SYSCLK / 4.0 101 = SYSCLK / 5.5 110 = SYSCLK / 6.0 111= Reserved
	1:0		00b	Reserved - Do Not Change
R08 (08h) Audio Interface (3)	15	AIF_MSTR1	0b	Audio Interface 1 Master Mode Select 0 = Slave mode 1 = Master mode
	14	AIF_MSTR2	0b	Audio Interface 2 Master Mode Select 0 = Slave mode 1 = Master mode
	13	AIF_SEL	0b	Audio Interface Select 0 = Audio interface 1 1 = Audio interface 2 (GPIO3/BCLK2, GPIO4/DACLRC2, GPIO5/DACDAT2)
	12		0b	Reserved - Do Not Change
	11	ADCLRC_DIR	0b	ADCLRC Direction (Forces ADCLRC clock to be output in slave mode) 0 = ADCLRC normal operation 1 = ADCLRC clock output enabled
	10:0	ADCLRC_RATE [10:0]	040h	ADCLRC Rate ADCLRC clock output = BCLK / ADCLRC_RATE Integer (LSB = 1) Valid from 8..2047
R09 (09h) Audio Interface (4)	15	ALRCGPIO1	0b	ADCLRC/GPIO1 Pin Function Select 0 = ADCLRC pin 1 = GPIO1 pin (ADCLRC connected to DACLRC internally)
	14	ALRCBGPIO6	0b	GPIO6/ADCLRCB Pin Function Select 0 = GPIO6 pin 1 = Inverted ADCLRC clock output
	13	AIF_TRIS	0b	Audio Interface and GPIO Tristate 0 = Audio interface and GPIO pins operate normally 1 = Tristate all audio interface and GPIO pins
	12		0b	Reserved - Do Not Change
	11	DACLRC_DIR	0b	DACLRC Direction (Forces DACLRC clock to be output in slave mode) 0 = DACLRC normal operation 1 = DACLRC clock output enabled

REGISTER ADDRESS	BIT	LABEL	DEFAULT	DESCRIPTION
	10:0	DACLRC_RATE [10:0]	040h	DACLRC Rate DACLRC clock output = BCLK / DACLRC_RATE Integer (LSB = 1) Valid from 8..2047
R10 (0Ah) DAC Control	15:13		000b	Reserved - Do Not Change
	12	DAC_SDMCLK_RATE	0b	DAC clocking rate 0 = Normal operation (64fs) 1 = SYSCLK/4
	11		0b	Reserved - Do Not Change
	10	AIF_LRCLKRATE	0b	LRCLK Rate 0 = Normal mode (256 * fs) 1 = USB mode (272 * fs)
	9	DAC_MONO	0b	DAC Mono Mix 0 = Stereo 1 = Mono (Mono mix output on enabled DACs)
	8	DAC_SB_FILTER	0b	Selects DAC filter characteristics 0 = Normal mode 1 = Sloping stopband mode
	7	DAC_MUTERATE	0b	DAC Soft Mute Ramp Rate 0 = Fast ramp (fs/2, maximum ramp time is 10.7ms at fs=48k) 1 = Slow ramp (fs/32, maximum ramp time is 171ms at fs=48k)
	6	DAC_MUTEMODE	0b	DAC Soft Mute Mode 0 = Disabling soft-mute (DAC_MUTE=0) will cause the DAC volume to change immediately to DACL_VOL and DACR_VOL settings 1 = Disabling soft-mute (DAC_MUTE=0) will cause the DAC volume to ramp up gradually to the DACL_VOL and DACR_VOL settings
	5:4	DEEMP	00b	DAC De-Emphasis Control 00 = De-emphasis disabled 01 = De-emphasis enabled (Optimised for fs=32kHz) 10 = De-emphasis enabled (Optimised for fs=44.1kHz) 11 = De-emphasis enabled (Optimised for fs=48kHz)
	3		0b	Reserved - Do Not Change
	2	DAC_MUTE	1b	DAC Soft Mute Control 0 = DAC Un-mute 1 = DAC Mute
	1	DACL_DATINV	0b	Left DAC Invert 0 = Left DAC output not inverted 1 = Left DAC output inverted
	0	DACR_DATINV	0b	Right DAC Invert 0 = Right DAC output not inverted 1 = Right DAC output inverted
R11 (0Bh) Left DAC Digital Volume	15:9		00h	Reserved - Do Not Change
	8	DAC_VU	N/A	DAC Volume Update Writing a 1 to this bit will cause left and right DAC volume to be updated simultaneously
	7:0	DACL_VOL [7:0]	1100_000 0b (0dB)	Left DAC Digital Volume (See Table 26 for volume settings)
R12 (0Ch)	15:9		00h	Reserved - Do Not Change

REGISTER ADDRESS	BIT	LABEL	DEFAULT	DESCRIPTION
Right DAC Digital Volume	8	DAC_VU	N/A	DAC Volume Update Writing a 1 to this bit will cause left and right DAC volume to be updated simultaneously
	7:0	DACR_VOL [7:0]	1100_0000b (0dB)	Right DAC Digital Volume (See Table 26 for volume settings)
R13 (0Dh) Digital Sidetone	15:13		000b	Reserved - Do Not Change
	12:9	ADCL_DAC_SVOL [3:0]	0000b	Left Channel Digital Sidetone Volume (See Table 23 for volume range)
	8:5	ADCR_DAC_SVOL [3:0]	0000b	Right Channel Digital Sidetone Volume (See Table 23 for volume range)
	4		0b	Reserved - Do Not Change
	3:2	ADC_TO_DACL [1:0]	00b	Left DAC Digital Sidetone Source 00 = No sidetone 01 = Left ADC 10 = Right ADC 11 = Reserved
	1:0	ADC_TO_DACR [1:0]	00b	Right DAC Digital Sidetone Source 00 = No sidetone 01 = Left ADC 10 = Right ADC 11 = Reserved
R14 (0Eh) ADC Control	15:9		00h	Reserved - Do Not Change
	8	ADC_HPF_ENA	1b	ADC Digital High Pass Filter Enable 0 = disabled 1 = enabled
	7		0b	Reserved - Do Not Change
	6:5	ADC_HPF_CUT [1:0]	00b	ADC Digital High Pass Filter Cut-Off Frequency (fc) 00 = Hi-fi mode (fc=4Hz at fs=48kHz) 01 = Voice mode 1 (fc=127Hz at fs=16kHz) 10 = Voice mode 2 (fc=130Hz at fs=8kHz) 11 = Voice mode 3 (fc=267Hz at fs=8kHz) (Note: fc scales with sample rate. See Table 18 for cut-off frequencies at all supported sample rates)
	4:2		000b	Reserved - Do Not Change
	1	ADCL_DATINV	0b	Left ADC Invert 0 = Left ADC output not inverted 1 = Left ADC output inverted
	0	ADCR_DATINV	0b	Right ADC Invert 0 = Right ADC output not inverted 1 = Right ADC output inverted
R15 (0Fh) Left ADC Digital Volume	15:9		00h	Reserved - Do Not Change
	8	ADC_VU	N/A	ADC Volume Update Writing a 1 to this bit will cause left and right ADC volume to be updated simultaneously
	7:0	ADCL_VOL [7:0]	1100_0000b (0dB)	Left ADC Digital Volume (See Table 16 for volume range)
R16 (10h) Right ADC Digital Volume	15:9		00h	Reserved - Do Not Change
	8	ADC_VU	N/A	ADC Volume Update Writing a 1 to this bit will cause left and right ADC volume to be updated simultaneously

REGISTER ADDRESS	BIT	LABEL	DEFAULT	DESCRIPTION
	7:0	ADCR_VOL [7:0]	1100_0000b (0dB)	Right ADC Digital Volume (See Table 16 for volume range)
R17 (11h)	15:0		0000h	Reserved - Do Not Change
R18 (12h)	15:13		0dB	Reserved - Do Not Change
GPIO Control (1)	12	IRQ (ro)	Read Only	IRQ Readback (Allows polling of IRQ status)
	11	TEMPOK (rr)	Read or Reset	Temperature OK status Read- 0 = Device temperature NOT ok 1 = Device temperature ok Write - 1 = Reset TEMPOK latch
	10	MICSHRT (rr)	Read or Reset	MICBIAS short status Read- 0 = MICBIAS ok 1 = MICBIAS shorted Write- 1 = Reset MICSHRT latch
	9	MICDET (rr)	Read or Reset	MICBIAS detect status MICBIAS microphone detect Readback Read- 0 = No Microphone detected 1 = Microphone detected Write- 1 = Reset MICDET latch
	8	PLL_LCK (rr)	Read or Reset	PLL Lock status Read- 0 = PLL NOT locked 1 = PLL locked Write- 1 = Reset PLL_LCK latch
	7:0	GPIO_STATUS [7:0] (rr)	Read or Reset	GPIO and GPI Input Pin Status GPIO_STATUS[7] = GPI8 pin status GPIO_STATUS[6] = GPI7 pin status GPIO_STATUS[5] = GPIO6 pin status GPIO_STATUS[4] = GPIO5 pin status GPIO_STATUS[3] = GPIO4 pin status GPIO_STATUS[2] = GPIO3 pin status GPIO_STATUS[1] = GPIO2 pin status GPIO_STATUS[0] = GPIO1 pin status
	R19 (13h) GPIO1 and GPIO2	15	GPIO2_DEB_ENA	0b
14		GPIO2_IRQ_ENA	0b	GPIO2 IRQ Enable 0 = disabled 1 = enabled (GPIO2 input will generate IRQ)
13		GPIO2_PU	0b	GPIO2 Pull-Up Resistor Enable 0 = Pull-up disabled 1 = Pull-up enabled (Approx 150kΩ)
12		GPIO2_PD	1b	GPIO2 Pull-Down Resistor Enable 0 = Pull-down disabled 1 = Pull-down enabled (Approx 150kΩ)

REGISTER ADDRESS	BIT	LABEL	DEFAULT	DESCRIPTION
	11:8	GPIO2_SEL [3:0]	0000b	GPIO2 Function Select 0000 = Input pin 0001 = Clock output (f=SYSCLK/OPCLKDIV) 0010 = Logic '0' 0011 = Logic '1' 0100 = PLL Lock output 0101 = Temperature OK output 0110 = SDOUT data output 0111 = IRQ output 1000 = MIC Detect 1001 = MIC Short Circuit Detect 1010 to 1111 = Reserved
	7	GPIO1_DEB_ENA	0b	GPIO1 Input De-Bounce 0 = disabled (Not de-bounced) 1 = enabled (Requires MCLK input and TOCLK_ENA=1)
	6	GPIO1_IRQ_ENA	0b	GPIO1 IRQ Enable 0 = disabled 1 = enabled (GPIO1 input will generate IRQ)
	5	GPIO1_PU	0b	GPIO1 Pull-Up Resistor Enable 0 = Pull-up disabled 1 = Pull-up enabled (Approx 150kΩ)
	4	GPIO1_PD	0b	GPIO1 Pull-Down Resistor Enable 0 = Pull-down disabled 1 = Pull-down enabled (Approx 150kΩ)
	3:0	GPIO1_SEL [3:0]	0000b	GPIO1 Function Select 0000 = Input pin 0001 = Clock output (f=SYSCLK/OPCLKDIV) 0010 = Logic '0' 0011 = Logic '1' 0100 = PLL Lock output 0101 = Temperature OK output 0110 = SDOUT data output 0111 = IRQ output 1000 = MIC Detect 1001 = MIC Short Circuit Detect 1010 to 1111 = Reserved
R20 (14h) GPIO3 and GPIO4	15	GPIO4_DEB_ENA	0b	GPIO4 Input De-Bounce 0 = disabled (Not de-bounced) 1 = enabled (Requires MCLK input and TOCLK_ENA=1)
	14	GPIO4_IRQ_ENA	0b	GPIO4 IRQ Enable 0 = disabled 1 = enabled (GPIO4 input will generate IRQ)
	13	GPIO4_PU	0b	GPIO4 Pull-Up Resistor Enable 0 = Pull-up disabled 1 = Pull-up enabled (Approx 150kΩ)
	12	GPIO4_PD	1b	GPIO4 Pull-Down Resistor Enable 0 = Pull-down disabled 1 = Pull-down enabled (Approx 150kΩ)

REGISTER ADDRESS	BIT	LABEL	DEFAULT	DESCRIPTION
	11:8	GPIO4_SEL [3:0]	0000b	GPIO4 Function Select 0000 = Input pin 0001 = Clock output (f=SYSCLK/OPCLKDIV) 0010 = Logic '0' 0011 = Logic '1' 0100 = PLL Lock output 0101 = Temperature OK output 0110 = SDOUT data output 0111 = IRQ output 1000 = MIC Detect 1001 = MIC Short Circuit Detect 1010 to 1111 = Reserved
	7	GPIO3_DEB_ENA	0b	GPIO3 Input De-Bounce 0 = disabled (Not de-bounced) 1 = enabled (Requires MCLK input and TOCLK_ENA=1)
	6	GPIO3_IRQ_ENA	0b	GPIO3 IRQ Enable 0 = disabled 1 = enabled (GPIO3 input will generate IRQ)
	5	GPIO3_PU	0b	GPIO3 Pull-Up Resistor Enable 0 = Pull-up disabled 1 = Pull-up enabled (Approx 150kΩ)
	4	GPIO3_PD	1b	GPIO3 Pull-Down Resistor Enable 0 = Pull-down disabled 1 = Pull-down enabled (Approx 150kΩ)
	3:0	GPIO3_SEL [3:0]	0000b	GPIO3 Function Select 0000 = Input pin 0001 = Clock output (f=SYSCLK/OPCLKDIV) 0010 = Logic '0' 0011 = Logic '1' 0100 = PLL Lock output 0101 = Temperature OK output 0110 = SDOUT data output 0111 = IRQ output 1000 = MIC Detect 1001 = MIC Short Circuit Detect 1010 to 1111 = Reserved
R21 (15h) GPIO5 and GPIO6	15	GPIO6_DEB_ENA	0b	GPIO6 Input De-Bounce 0 = disabled (Not de-bounced) 1 = enabled (Requires MCLK input and TOCLK_ENA=1)
	14	GPIO6_IRQ_ENA	0b	GPIO6 IRQ Enable 0 = disabled 1 = enabled (GPIO6 input will generate IRQ)
	13	GPIO6_PU	0b	GPIO6 Pull-Up Resistor Enable 0 = Pull-up disabled 1 = Pull-up enabled (Approx 150kΩ)
	12	GPIO6_PD	1b	GPIO6 Pull-Down Resistor Enable 0 = Pull-down disabled 1 = Pull-down enabled (Approx 150kΩ)

REGISTER ADDRESS	BIT	LABEL	DEFAULT	DESCRIPTION
	11:8	GPIO6_SEL [3:0]	0000b	GPIO6 Function Select 0000 = Input pin 0001 = Clock output (f=SYSCLK/OPCLKDIV) 0010 = Logic '0' 0011 = Logic '1' 0100 = PLL Lock output 0101 = Temperature OK output 0110 = SDOUT data output 0111 = IRQ output 1000 = MIC Detect 1001 = MIC Short Circuit Detect 1010 to 1111 = Reserved
	7	GPIO5_DEB_ENA	0b	GPIO5 Input De-Bounce 0 = disabled (Not de-bounced) 1 = enabled (Requires MCLK input and TOCLK_ENA=1)
	6	GPIO5_IRQ_ENA	0b	GPIO5 IRQ Enable 0 = disabled 1 = enabled (GPIO5 input will generate IRQ)
	5	GPIO5_PU	0b	GPIO5 Pull-Up Resistor Enable 0 = Pull-up disabled 1 = Pull-up enabled (Approx 150kΩ)
	4	GPIO5_PD	1b	GPIO5 Pull-Down Resistor Enable 0 = Pull-down disabled 1 = Pull-down enabled (Approx 150kΩ)
	3:0	GPIO5_SEL [3:0]	0000b	GPIO5 Function Select 0000 = Input pin 0001 = Clock output (f=SYSCLK/OPCLKDIV) 0010 = Logic '0' 0011 = Logic '1' 0100 = PLL Lock output 0101 = Temperature OK output 0110 = SDOUT data output 0111 = IRQ output 1000 = MIC Detect 1001 = MIC Short Circuit Detect 1010 to 1111 = Reserved
R22 (16h) GPI7 and GPI8	15	RD_3W_ENA	1b	3- / 4-wire readback configuration 1 = 3-wire mode 0 = 4-wire mode, using GPIO pin
	14	MODE_3W4W	0b	3-wire mode 0 = push 0/1 1 = open-drain 4-wire mode 0 = push 0/1 1 = wired-OR
	13:12		00b	Reserved - Do Not Change
	11	TEMPOK_IRQ_ENA	0b	Temperature Sensor IRQ Enable 0 = disabled 1 = enabled
	10	MICSHRT_IRQ_ENA	0b	MICBIAS short circuit detect IRQ Enable 0 = disabled 1 = enabled

REGISTER ADDRESS	BIT	LABEL	DEFAULT	DESCRIPTION
	9	MICDET_IRQ_ENA	0b	MICBIAS current detect IRQ Enable 0 = disabled 1 = enabled
	8	PLL_LCK_IRQ_ENA	0b	PLL Lock IRQ Enable 0 = disabled 1 = enabled
	7	GPI8_DEB_ENA	0b	GPI8 Input De-Bounce 0 = disabled (Not de-bounced) 1 = enabled (Requires MCLK input and TOCLK_ENA=1)
	6	GPI8_IRQ_ENA	0b	GPI8 IRQ Enable 0 = disabled 1 = enabled (GPI8 input will generate IRQ)
	5		0b	Reserved - Do Not Change
	4	GPI8_ENA	0b	GPI8 Input Pin Enable 0 = RIN3/GPI8 pin disabled as GPI8 input 1 = RIN3/GPI8 pin enabled as GPI8 input
	3	GPI7_DEB_ENA	0b	GPI7 Input De-Bounce 0 = disabled (Not de-bounced) 1 = enabled (Requires MCLK input and TOCLK_ENA=1)
	2	GPI7_IRQ_ENA	0b	GPI7 IRQ Enable 0 = disabled 1 = enabled (GPI7 input will generate IRQ)
	1		0b	Reserved - Do Not Change
	0	GPI7_ENA	0b	GPI7 Input Pin Enable 0 = LIN3/GPI7 pin disabled as GPI7 input 1 = LIN3/GPI7 pin enabled as GPI7 input
R23 (17h) GPIO Control (2)	15:13		0000b	Reserved - Do Not Change
	12	IRQ_INV (rw)	0b	IRQ Invert 0 = IRQ output active high 1 = IRQ output active low
	11	TEMPOK_POL (rw)	1b	Temperature Sensor polarity 0 = Non-inverted 1 = Inverted
	10	MICSHRT_POL (rw)	0b	MICBIAS short circuit detect polarity 0 = Non-inverted 1 = Inverted
	9	MICDET_POL (rw)	0b	MICBIAS current detect polarity 0 = Non-inverted 1 = Inverted
	8	PLL_LCK_POL (rw)	0b	PLL Lock Polarity 0 = Non-inverted 1 = Inverted
	7:0	GPIO_POL[7:0] (rw)	00h	GPIO On Input Polarity 0 = Non-inverted 1 = Inverted GPIO_POL[7]: GPI8 polarity GPIO_POL[6]: GPI7 polarity GPIO_POL[5]: GPIO6 polarity GPIO_POL[4]: GPIO5 polarity GPIO_POL[3]: GPIO4 polarity GPIO_POL[2]: GPIO3 polarity GPIO_POL[1]: GPIO2 polarity GPIO_POL[0]: GPIO1 polarity
R24 (18h)	15:9		00h	Reserved - Do Not Change

REGISTER ADDRESS	BIT	LABEL	DEFAULT	DESCRIPTION
LIN12 Input PGA Volume	8	IPVU[0]	N/A	Input PGA Volume Update Writing a 1 to this bit will cause all input PGA volumes to be updated simultaneously (LIN12, LIN34, RIN12 and RIN34)
	7	LI12MUTE	1b	LIN12 PGA Mute 0 = Disable Mute 1 = Enable Mute
	6	LI12ZC	0b	LIN12 PGA Zero Cross Detector 0 = Change gain immediately 1 = Change gain on zero cross only
	5		0b	Reserved - Do Not Change
	4:0	LIN12VOL [4:0]	01011b	LIN12 Volume (See Table 6 for PGA volume range)
R25 (19h) LIN34 Input PGA Volume	15:9		00h	Reserved - Do Not Change
	8	IPVU[1]	N/A	Input PGA Volume Update Writing a 1 to this bit will cause all input PGA volumes to be updated simultaneously (LIN12, LIN34, RIN12 and RIN34)
	7	LI34MUTE	1b	LIN34 PGA Mute 0 = Disable Mute 1 = Enable Mute
	6	LI34ZC	0b	LIN34 PGA Zero Cross Detector 0 = Change gain immediately 1 = Change gain on zero cross only
	5		0b	Reserved - Do Not Change
	4:0	LIN34VOL [4:0]	01011b	LIN34 Volume (See Table 6 for PGA volume range)
R26 (1Ah) RIN12 Input PGA Volume	15:9		00h	Reserved - Do Not Change
	8	IPVU[2]	N/A	Input PGA Volume Update Writing a 1 to this bit will cause all input PGA volumes to be updated simultaneously (LIN12, LIN34, RIN12 and RIN34)
	7	RI12MUTE	1b	RIN12 PGA Mute 0 = Disable Mute 1 = Enable Mute
	6	RI12ZC	0b	RIN12 PGA Zero Cross Detector 0 = Change gain immediately 1 = Change gain on zero cross only
	5		0b	Reserved - Do Not Change
4:0	RIN12VOL [4:0]	01011b	RIN12 Volume (See Table 6 for PGA volume range)	
R27 (1Bh) RIN34 Input PGA Volume	15:9		00h	Reserved - Do Not Change
	8	IPVU[3]	N/A	Input PGA Volume Update Writing a 1 to this bit will cause all input PGA volumes to be updated simultaneously (LIN12, LIN34, RIN12 and RIN34)
	7	RI34MUTE	1b	RIN34 PGA Mute 0 = Disable Mute 1 = Enable Mute
	6	RI34ZC	0b	RIN34 PGA Zero Cross Detector 0 = Change gain immediately 1 = Change gain on zero cross only
	5		0b	Reserved - Do Not Change
	4:0	RIN34VOL [4:0]	01011b	RIN34 Volume (See Table 6 for PGA volume range)

REGISTER ADDRESS	BIT	LABEL	DEFAULT	DESCRIPTION
R28 (1Ch) Left Headphone Output Volume	15:9		00h	Reserved - Do Not Change
	8	OPVU[0]	N/A	Output PGA Volume Update Writing a 1 to this bit will update LOPGA, ROPGA, LOUVOL and ROUVOL volumes simultaneously.
	7	LOZC	0b	Left Headphone Output Zero Cross Enable 0 = Zero cross disabled 1 = Zero cross enabled
	6:0	LOUVOL [6:0]	00h (mute)	Left Headphone Output Volume (See Table 36 for output PGA volume control range)
R29 (1Dh) Right Headphone Output Volume	15:9		00h	Reserved - Do Not Change
	8	OPVU[1]	N/A	Output PGA Volume Update Writing a 1 to this bit will update LOPGA, ROPGA, LOUVOL and ROUVOL volumes simultaneously.
	7	ROZC	0b	Right Headphone Output Zero Cross Enable 0 = Zero cross disabled 1 = Zero cross enabled
	6:0	ROUVOL [6:0]	00h (mute)	Right Headphone Output Volume (See Table 36 for output PGA volume control range)
R30 (1Eh) Line Output Volume	15:7		000h	Reserved - Do Not Change
	6	LONMUTE	1b	LON Line Output Mute 0 = Un-mute 1 = Mute
	5	LOPMUTE	1b	LOP Line Output Mute 0 = Un-mute 1 = Mute
	4	LOATTN	0b	LOP Attenuation 0 = 0dB 1 = -6dB
	3		0b	Reserved - Do Not Change
	2	RONMUTE	1b	RON Line Output Mute 0 = Un-mute 1 = Mute
	1	ROPMUTE	1b	ROP Line Output Mute 0 = Un-mute 1 = Mute
	0	ROATTN	0b	ROP Attenuation 0 = 0dB 1 = -6dB
R31 (1Fh) OUT3 and OUT4 Volume	15:6		00000000 00b	Reserved - Do Not Change
	5	OUT3MUTE	1b	OUT3 Mute 0 = Un-mute 1 = Mute
	4	OUT3ATTN	0b	OUT3 Attenuation 0 = 0dB 1 = -6dB
	3:2		00b	Reserved - Do Not Change
	1	OUT4MUTE	1b	OUT4 Mute 0 = Un-mute 1 = Mute
	0	OUT4ATTN	0b	OUT4 Attenuation 0 = 0dB 1 = -6dB
R32 (20h)	15:9		00h	Reserved - Do Not Change

REGISTER ADDRESS	BIT	LABEL	DEFAULT	DESCRIPTION
LOPGA Volume	8	OPVU[2]	N/A	Output PGA Volume Update Writing a 1 to this bit will update LOPGA, ROPGA, LOUTVOL and ROUTVOL volumes simultaneously.
	7	LOPGAZC	0b	LOPGA Zero Cross Enable 0 = Zero cross disabled 1 = Zero cross enabled
	6:0	LOPGAVOL [6:0]	79h (0dB)	LOPGA Volume (See Table 36 for output PGA volume control range)
R33 (21h) ROPGA Volume	15:9		00h	Reserved - Do Not Change
	8	OPVU[3]	N/A	Output PGA Volume Update Writing a 1 to this bit will update LOPGA, ROPGA, LOUTVOL and ROUTVOL volumes simultaneously.
	7	ROPGAZC	0b	ROPGA Zero Cross Enable 0 = Zero cross disabled 1 = Zero cross enabled
R34 (22h) Speaker Volume	6:0	ROPGAVOL [6:0]	79h (0dB)	ROPGA Volume (See Table 36 for output PGA volume control range)
	15:2		0000h	Reserved - Do Not Change
R35 (23h) Class D (1)	1:0	SPKATTN [1:0]	11b	Speaker Output Attenuation (SPKN and SPKP) 00 = 0dB 01 = -6dB 10 = -12dB 11 = mute
	8	CDMODE	0b	Speaker Class D Mode Enable 0 = Class D mode 1 = Class AB mode
R36 (24h) Class D (2)	7:0		00000011b	Reserved - Do Not Change
	15:0		0055h	Reserved - Do Not Change
R37 (25h) Class D (3)	15:6		0000000100b	Reserved - Do Not Change
	5:3	DCGAIN [2:0]	000b	DC Speaker Boost 000 = 1.00x boost (+0dB) 001 = 1.27x boost (+2.1dB) 010 = 1.40x boost (+2.9dB) 011 = 1.52x boost (+3.6dB) 100 = 1.67x boost (+4.5dB) 101 = 1.8x boost (+5.1dB) 110 to 111 = Reserved
	2:0	ACGAIN [2:0]	000b	AC Speaker Boost 000 = 1.00x boost (+0dB) 001 = 1.27x boost (+2.1dB) 010 = 1.40x boost (+2.9dB) 011 = 1.52x boost (+3.6dB) 100 = 1.67x boost (+4.5dB) 101 = 1.8x boost (+5.1dB) 110 to 111 = Reserved
R38 (26h) Class D (4)	15:8		00h	Reserved - Do Not Change
	7	SPKZC	0b	SPKPGA Zero Cross Enable 0 = Zero cross disabled 1 = Zero cross enabled

REGISTER ADDRESS	BIT	LABEL	DEFAULT	DESCRIPTION
	6:0	SPKVOL [6:0]	79h (0dB)	SPKPGA Volume (see Table 36 for SPKPGA volume control range)
R39 (27h) Input Mixers (1)	15:4		000h	Reserved - Do Not Change
	3:2	AINLMODE [1:0]	00b	AINLMUX Input Source 00 = INMIXL (Left Input Mixer) 01 = RXVOICE (RXP - RXN) 10 = DIFFINL (LIN12 PGA - LIN34 PGA) 11 = (Reserved)
	1:0	AINRMODE [1:0]	00b	AINRMUX Input Source 00 = INMIXR (Right Input Mixer) 01 = RXVOICE (RXP - RXN) 10 = DIFFINR (RIN12 PGA - RIN34 PGA) 11 = (Reserved)
R40 (28h) Input Mixers (2)	15:8		00h	Reserved - Do Not Change
	7	LMP4	0b	LIN34 PGA Non-Inverting Input Select 0 = LIN4 not connected to PGA 1 = LIN4 connected to PGA
	6	LMN3	0b	LIN34 PGA Inverting Input Select 0 = LIN3 not connected to PGA 1 = LIN3 connected to PGA
	5	LMP2	0b	LIN12 PGA Non-Inverting Input Select 0 = LIN2 not connected to PGA 1 = LIN2 connected to PGA
	4	LMN1	0b	LIN12 PGA Inverting Input Select 0 = LIN1 not connected to PGA 1 = LIN1 connected to PGA
	3	RMP4	0b	RIN34 PGA Non-Inverting Input Select 0 = RIN4 not connected to PGA 1 = RIN4 connected to PGA
	2	RMN3	0b	RIN34 PGA Inverting Input Select 0 = RIN3 not connected to PGA 1 = RIN3 connected to PGA
	1	RMP2	0b	RIN12 PGA Non-Inverting Input Select 0 = RIN2 not connected to PGA 1 = RIN2 connected to PGA
	0	RMN1	0b	RIN12 PGA Inverting Input Select 0 = RIN1 not connected to PGA 1 = RIN1 connected to PGA
	R41 (29h) Input Mixers (3)	15:9		00h
8		L34MNB	0b	LIN34 PGA Output to INMIXL Mute 0 = Mute 1 = Un-Mute
7		L34MNBST	0b	LIN34 PGA Output to INMIXL Gain 0 = 0dB 1 = +30dB
6			0b	Reserved - Do Not Change
5		L12MNB	0b	LIN12 PGA Output to INMIXL Mute 0 = Mute 1 = Un-Mute
4		L12MNBST	0b	LIN12 PGA Output to INMIXL Gain 0 = 0dB 1 = +30dB
	3		0b	Reserved - Do Not Change

REGISTER ADDRESS	BIT	LABEL	DEFAULT	DESCRIPTION
	2:0	LDBVOL [2:0]	000b	LOMIX to INMIXL Gain and Mute 000 = Mute 001 = -12dB 010 = -9dB 011 = -6dB 100 = -3dB 101 = 0dB 110 = +3dB 111 = +6dB
R42 (2Ah) Input Mixers (4)	15:9		00h	Reserved - Do Not Change
	8	R34MNB	0b	RIN34 PGA Output to INMIXR Mute 0 = Mute 1 = Un-Mute
	7	R34MNBST	0b	RIN34 PGA Output to INMIXR Gain 0 = 0dB 1 = +30dB
	6		0b	Reserved - Do Not Change
	5	R12MNB	0b	RIN12 PGA Output to INMIXR Mute 0 = Mute 1 = Un-Mute
	4	R12MNBST	0b	RIN12 PGA Output to INMIXR Gain 0 = 0dB 1 = +30dB
	3		0b	Reserved - Do Not Change
	2:0	RDBVOL [2:0]	000b	ROMIX to INMIXR Gain and Mute 000 = Mute 001 = -12dB 010 = -9dB 011 = -6dB 100 = -3dB 101 = 0dB 110 = +3dB 111 = +6dB
R43 (2Bh) Input Mixers (5)	15:9		00h	Reserved - Do Not Change
	8:6	LI2BVOL [2:0]	000b	LIN2 Pin to INMIXL Gain and Mute 000 = Mute 001 = -12dB 010 = -9dB 011 = -6dB 100 = -3dB 101 = 0dB 110 = +3dB 111 = +6dB
	5:3	LR4BVOL [2:0]	000b	RXVOICE to AINLMUX Gain and Mute 000 = Mute 001 = -12dB 010 = -9dB 011 = -6dB 100 = -3dB 101 = 0dB 110 = +3dB 111 = +6dB

REGISTER ADDRESS	BIT	LABEL	DEFAULT	DESCRIPTION
	2:0	LL4BVOL [2:0]	000b	LIN4/RXN Pin to INMIXL Gain and Mute 000 = Mute 001 = -12dB 010 = -9dB 011 = -6dB 100 = -3dB 101 = 0dB 110 = +3dB 111 = +6dB
R44 (2Ch) Input Mixers (6)	15:9		00h	Reserved - Do Not Change
	8:6	RI2BVOL [2:0]	000b	RIN2 Pin to INMIXR Gain and Mute 000 = Mute 001 = -12dB 010 = -9dB 011 = -6dB 100 = -3dB 101 = 0dB 110 = +3dB 111 = +6dB
	5:3	RL4BVOL [2:0]	000b	RXVOICE to AINRMUX Gain and Mute 000 = Mute 001 = -12dB 010 = -9dB 011 = -6dB 100 = -3dB 101 = 0dB 110 = +3dB 111 = +6dB
	2:0	RR4BVOL [2:0]	000b	RIN4/RXP Pin to INMIXR Gain and Mute 000 = Mute 001 = -12dB 010 = -9dB 011 = -6dB 100 = -3dB 101 = 0dB 110 = +3dB 111 = +6dB
R45 (2Dh) Output Mixers (1)	15:8		00h	Reserved - Do Not Change
	7	LRBLO	0b	AINRMUX Output (Right ADC bypass) to LOMIX Mute 0 = Mute 1 = Un-mute
	6	LLBLO	0b	AINLMUX Output (Left ADC bypass) to LOMIX Mute 0 = Mute 1 = Un-mute
	5	LRI3LO	0b	RIN3 to LOMIX Mute 0 = Mute 1 = Un-mute
	4	LLI3LO	0b	LIN3 to LOMIX Mute 0 = Mute 1 = Un-mute
	3	LR12LO	0b	RIN12 PGA Output to LOMIX Mute 0 = Mute 1 = Un-mute

REGISTER ADDRESS	BIT	LABEL	DEFAULT	DESCRIPTION
	2	LL12LO	0b	LIN12 PGA Output to LOMIX Mute 0 = Mute 1 = Un-mute
	1		0b	Reserved - Do Not Change
	0	LDLO	0b	Left DAC to LOMIX Mute 0 = Mute 1 = Un-mute Note: LDLO must be muted when LDSPK=1
R46 (2Eh) Output Mixers (2)	15:8		00h	Reserved - Do Not Change
	7	RLBRO	0b	AINLMUX Output (Left ADC bypass) to ROMIX Mute 0 = Mute 1 = Un-mute
	6	RRBRO	0b	AINRMUX Output (Right ADC bypass) to ROMIX 0 = Mute 1 = Un-mute
	5	RLI3RO	0b	LIN3 to ROMIX Mute 0 = Mute 1 = Un-mute
	4	RRI3RO	0b	RIN3 to ROMIX Mute 0 = Mute 1 = Un-mute
	3	RL12RO	0b	LIN12 PGA Output to ROMIX Mute 0 = Mute 1 = Un-mute
	2	RR12RO	0b	RIN12 PGA Output to ROMIX Mute 0 = Mute 1 = Un-mute
	1		0b	Reserved - Do Not Change
	0	RDRO	0b	Right DAC to ROMIX Mute 0 = Mute 1 = Un-mute Note: RDRO must be muted when RDSPK=1
R47 (2Fh) Output Mixers (3)	15:9		00h	Reserved - Do Not Change
	8:6	LLI3LOVOL [2:0]	000b	LIN3 Pin to LOMIX Volume (See Table 34 for Volume Range)
	5:3	LR12LOVOL [2:0]	000b	RIN12 PGA Output to LOMIX Volume (See Table 34 for Volume Range)
2:0	LL12LOVOL [2:0]	000b	LIN12 PGA Output to LOMIX Volume (See Table 34 for Volume Range)	
R48 (30h) Output Mixers (4)	15:9		00h	Reserved - Do Not Change
	8:6	RRI3ROVOL [2:0]	000b	RIN3 to ROMIX Volume (See Table 34 for Volume Range)
	5:3	RL12ROVOL [2:0]	000b	LIN12 PGA Output to ROMIX Volume (See Table 34 for Volume Range)
2:0	RR12ROVOL [2:0]	000b	RIN12 PGA Output to ROMIX Volume (See Table 34 for Volume Range)	
R49 (31h) Output Mixers (5)	15:9		000h	Reserved - Do Not Change
	8:6	LRI3LOVOL [2:0]	000b	RIN3 to LOMIX Volume (See Table 34 for Volume Range)
	5:3	LRBLOVOL [2:0]	000b	AINRMUX Output (Right ADC bypass) to LOMIX Volume (See Table 34 for Volume Range)
2:0	LLBLOVOL [2:0]	000b	AINLMUX Output (Left ADC bypass) to LOMIX Volume (See Table 34 for Volume Range)	

REGISTER ADDRESS	BIT	LABEL	DEFAULT	DESCRIPTION
R50 (32h) Output Mixers (6)	15:9		00h	Reserved - Do Not Change
	8:6	RLI3ROVOL [2:0]	000b	LIN3 to ROMIX Volume (See Table 34 for Volume Range)
	5:3	RLBROVOL [2:0]	000b	AINLMUX Output (Left ADC bypass) to ROMIX Volume (See Table 34 for Volume Range)
	2:0	RRBROVOL [2:0]	000b	AINRMUX Output (Right ADC bypass) to ROMIX Volume (See Table 34 for Volume Range)
R51 (33h) OUT3 and OUT4 Mixers	15:9		00h	Reserved - Do Not Change
	8:7	VSEL [1:0]	11b	Analogue Bias Optimisation 00 = Reserved 01 = Bias current optimized for AVDD=2.7V 1X = Lowest bias current, optimized for AVDD=3.3V
	6		0b	Reserved - Do Not Change
	5	LI4O3	0b	LIN4/RXN Pin to OUT3MIX 0 = Mute 1 = Un-mute
	4	LPGA03	0b	LOPGA to OUT3MIX 0 = Mute 1 = Un-mute
	3:2		00b	Reserved - Do Not Change
	1	RI4O4	0b	RIN4/RXP Pin to OUT4MIX 0 = Mute 1 = Un-mute
	0	RPGA04	0b	ROPGA to OUT4MIX 0 = Mute 1 = Un-mute
R52 (34h) Line Output Mixers (1)	15:7		000h	Reserved - Do Not Change
	6	LLOPGALON	0b	LOPGA to LONMIX 0 = Mute 1 = Un-mute
	5	LROPGALON	0b	ROPGA to LONMIX 0 = Mute 1 = Un-mute
	4	LOPLON	0b	Inverted LOP Output to LONMIX 0 = Mute 1 = Un-mute
	3		0b	Reserved - Do Not Change
	2	LR12LOP	0b	RIN12 PGA Output to LOPMIX 0 = Mute 1 = Un-mute
	1	LL12LOP	0b	LIN12 PGA Output to LOPMIX 0 = Mute 1 = Un-mute
	0	LLOPGALOP	0b	LOPGA to LOPMIX 0 = Mute 1 = Un-mute
R53 (35h) Line Output Mixers (2)	15:7		000h	Reserved - Do Not Change
	6	RROPGARON	0b	ROPGA to RONMIX 0 = Mute 1 = Un-mute
	5	RLOPGARON	0b	LOPGA to RONMIX 0 = Mute 1 = Un-mute

REGISTER ADDRESS	BIT	LABEL	DEFAULT	DESCRIPTION
	4	ROPRON	0b	Inverted ROP Output to RONMIX 0 = Mute 1 = Un-mute
	3		0b	Reserved - Do Not Change
	2	RL12ROP	0b	LIN12 PGA Output to ROPMIX 0 = Mute 1 = Un-mute
	1	RR12ROP	0b	RIN12 PGA Output to ROPMIX 0 = Mute 1 = Un-mute
	0	RROPGAROP	0b	ROPGA to ROPMIX 0 = Mute 1 = Un-mute
R54 (36h) Speaker Output Mixer	15:8		000h	Reserved - Do Not Change
	7	LB2SPK	0b	AINLMUX Output to SPKMIX 0 = Mute 1 = Un-mute
	6	RB2SPK	0b	AINRMUX Output to SPKMIX 0 = Mute 1 = Un-mute
	5	LI2SPK	0b	LIN2 to SPKMIX 0 = Mute 1 = Un-mute
	4	RI2SPK	0b	RIN2 to SPKMIX 0 = Mute 1 = Un-mute
	3	LOPGASPK	0b	LOPGA to SPKMIX 0 = Mute 1 = Un-mute
	2	ROPGASPK	0b	ROPGA to SPKMIX 0 = Mute 1 = Un-mute
	1	LDSPK	0b	Left DAC to SPKMIX 0 = Mute 1 = Un-mute Note: LDSPK must be muted when LDLO=1
	0	RDSPK	0b	Right DAC to SPKMIX 0 = Mute 1 = Un-mute Note: RDSPK must be muted when RDRO=1
R55 (37h) Additional Control	15:1		0000h	Reserved - Do Not Change
	0	VROI	0b	VREF to Analogue Output Resistance (Disabled Outputs) 0 = 20k Ω (Headphone) or 10k Ω (Line Out) from buffered VMID to output 1 = 500 Ω from buffered VMID to output
R56 (38h) Anti-Pop (1)	15:6		000h	Reserved - Do Not Change
	5	DIS_LLINE	0b	Discharges LOP and LON outputs via approx 500 Ω resistor 0 = Not active 1 = Actively discharging LOP and LON
	4	DIS_RLINE	0b	Discharges ROP and RON outputs via approx 500 Ω resistor 0 = Not active 1 = Actively discharging ROP and RON

REGISTER ADDRESS	BIT	LABEL	DEFAULT	DESCRIPTION
	3	DIS_OUT3	0b	Discharges OUT3 output via approx 500Ω resistor 0 = Not active 1 = Actively discharging OUT3
	2	DIS_OUT4	0b	Discharges OUT4 output via approx 500Ω resistor 0 = Not active 1 = Actively discharging OUT4
	1	DIS_LOUT	0b	Discharges LOUT output via approx 500Ω resistor 0 = Not active 1 = Actively discharging LOUT
	0	DIS_ROUT	0b	Discharges ROUT output via approx 500Ω resistor 0 = Not active 1 = Actively discharging ROUT
R57 (39h) Anti-Pop (2)	15:7		0000_000 0_0b	Reserved - Do Not Change
	6	SOFTST	0b	Enables VMID soft start 0 = Disabled 1 = Enabled
	5:4		00b	Reserved - Do Not Change
	3	BUFIOEN	0b	Enables the VGS / R current generator and the analogue input and output bias 0 = Disabled 1 = Enabled
	2	BUFDOPEN	0b	Enables the VGS / R current generator 0 = Disabled 1 = Enabled
	1	POBCTRL	0b	Selects the bias current source for output amplifiers and VMID buffer 0 = VMID / R bias 1 = VGS / R bias
	0	VMIDTOG	0b	Connects VMID to ground 0 = Disabled 1 = Enabled
R58 (3Ah) Microphone Bias	15:8		0000_000 0b	Reserved - Do Not Change
	7:6	MCDSCTH [1:0]	00b	MICBIAS Short Circuit Current Detect Threshold 00 = 600uA 01 = 120uA 10 = 1800uA 11 = 2400uA These values are for AVDD=3.3V and scale proportionally with AVDD.
	5:3	MDCTHR [2:0]	000b	MICBIAS Current Detect Threshold 000 = 200uA 001 = 350uA 010 = 500uA 011 = 650uA 100 = 800uA 101 = 950uA 110 = 1100uA 111 = 1200uA These values are for AVDD=3.3V and scale proportionally with AVDD.
	2	MCD	0b	MICBIAS Current and Short Circuit Detect Enable 0 = disabled 1 = enabled

REGISTER ADDRESS	BIT	LABEL	DEFAULT	DESCRIPTION
	1		0b	Reserved - Do Not Change
	0	MBSEL	0b	Microphone Bias Voltage Control 0 = 0.9 * AVDD 1 = 0.65 * AVDD
R59 (3Bh)	15:0		0000h	Reserved - Do Not Change
R60 (3Ch)	15:8		00h	Reserved - Do Not Change
PLL (1)	7	SDM	0b	Enable PLL Integer Mode 0 = Integer mode 1 = Fractional mode
	6	PRESCALE	0b	Divide MCLK by 2 at PLL input 0 = Divide by 1 1 = Divide by 2
	5		0b	Reserved - Do Not Change
	4		0b	Reserved - Do Not Change
	3:0	PLLN [3:0]	8h	Integer (N) part of PLL frequency ratio. Use values greater than 5 and less than 13.
	R61 (3Dh)	15:8		00h
PLL (2)	7:0	PLLK [15:8]	31h	Fractional (K) part of PLL frequency ratio (Most significant bits)
	15:8		00h	Reserved - Do Not Change
PLL (3)	7:0	PLLK [7:0]	26h	Fractional (K) part of PLL frequency ratio (Least significant bits)
	15:8		00h	Reserved - Do Not Change
R63 (3Fh) to R127 (7Fh)	Reserved			

DIGITAL FILTER CHARACTERISTICS

PARAMETER	TEST CONDITIONS	MIN	TYP	MAX	UNIT
ADC Filter					
Passband	+/- 0.05dB	0		0.454 fs	
	-6dB		0.5fs		
Passband Ripple				+/- 0.05	dB
Stopband		0.546s			
Stopband Attenuation	f > 0.546 fs	-60			dB
DAC Normal Filter					
Passband	+/- 0.03dB	0		0.454 fs	
	-6dB		0.5 fs		
Passband Ripple	0.454 fs			+/- 0.03	dB
Stopband		0.546 fs			
Stopband Attenuation	F > 0.546 fs	-50			dB
DAC Sloping Stopband Filter					
Passband	+/- 0.03dB	0		0.25 fs	
	+/- 1dB	0.25 fs		0.454 fs	
	-6dB		0.5 fs		
Passband Ripple	0.25 fs			+/- 0.03	dB
Stopband 1		0.546 fs		0.7 fs	
Stopband 1 Attenuation	f > 0.546 fs	-60			dB
Stopband 2		0.7 fs		1.4 fs	
Stopband 2 Attenuation	f > 0.7 fs	-85			dB
Stopband 3		1.4 fs			
Stopband 3 Attenuation	F > 1.4 fs	-55			dB

DAC FILTERS		ADC FILTERS	
Mode	Group Delay	Mode	Group Delay
Normal	18 / fs	Normal	18 / fs
Sloping Stopband	18 / fs		

ADC FILTER RESPONSES

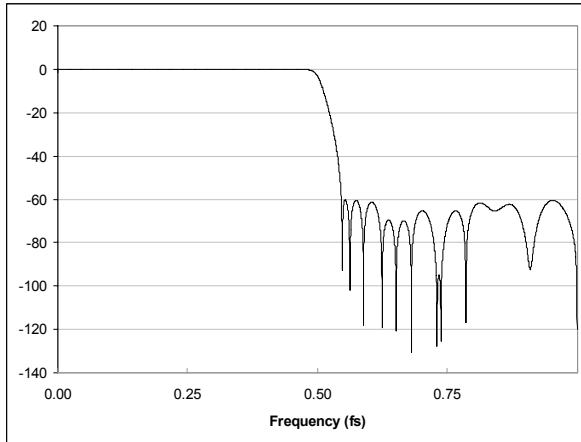

Figure 90 ADC Digital Filter Frequency Response

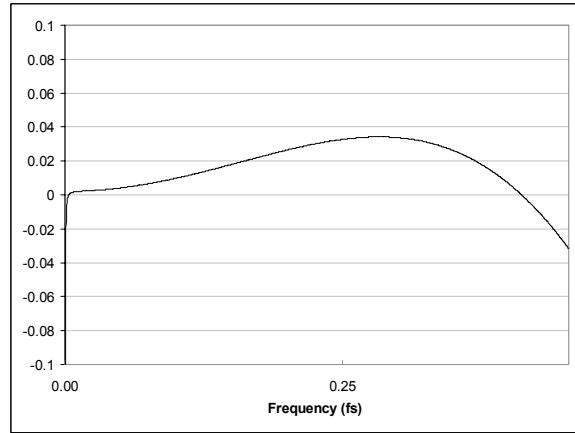

Figure 91 ADC Digital Filter Ripple

ADC HIGH PASS FILTER RESPONSES

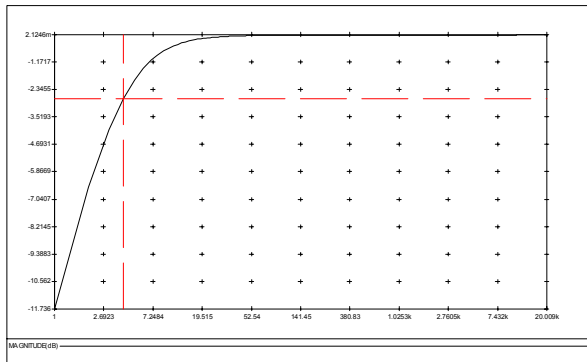

Figure 92 ADC Digital High Pass Filter Frequency Response (48kHz, Hi-Fi Mode, ADC_HPF_CUT[1:0]=00)

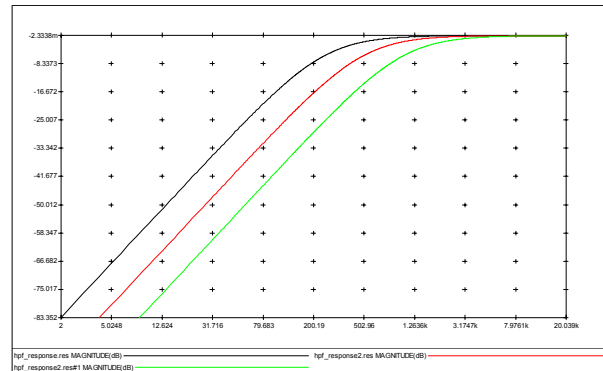

Figure 93 ADC Digital High Pass Filter Ripple (48kHz, Voice Mode, ADC_HPF_CUT=01, 10 and 11)

DAC FILTER RESPONSES

DAC STOPBAND ATTENUATION

The DAC digital filter type is selected by the DAC_SB_FILT register bit as shown in Table 91.

REGISTER ADDRESS	BIT	LABEL	DEFAULT	DESCRIPTION
R10 (0Ah)	8	DAC_SB_FILT	0b	Selects DAC filter characteristics 0 = Normal mode 1 = Sloping stopband mode

Table 91 DAC Filter Selection

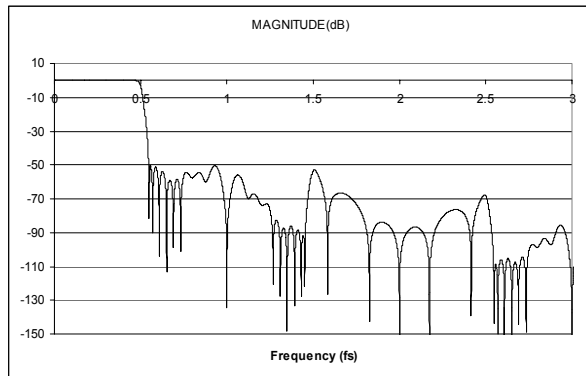

Figure 94 DAC Digital Filter Frequency Response (Normal Mode)

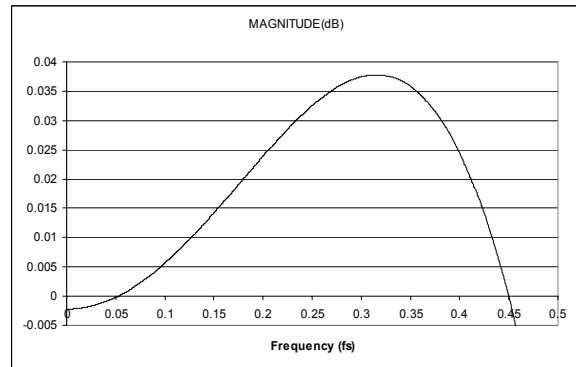

Figure 95 DAC Digital Filter Ripple (Normal Mode)

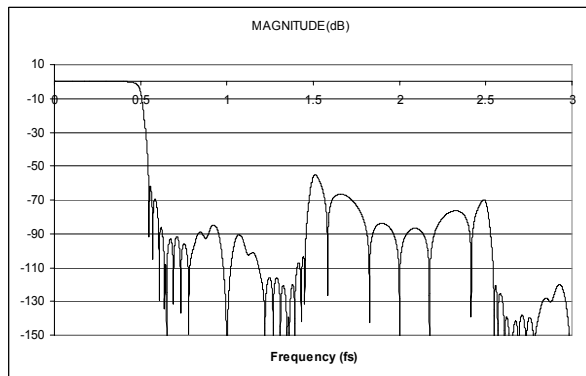

Figure 96 DAC Digital Filter Frequency Response (Sloping Stopband Mode)

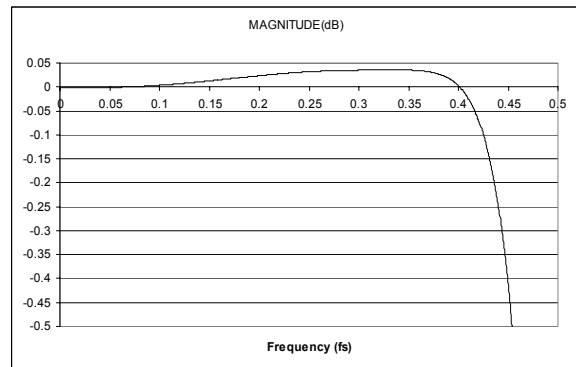

Figure 97 DAC Digital Filter Ripple (Sloping Stopband Mode)

DE-EMPHASIS FILTER RESPONSES

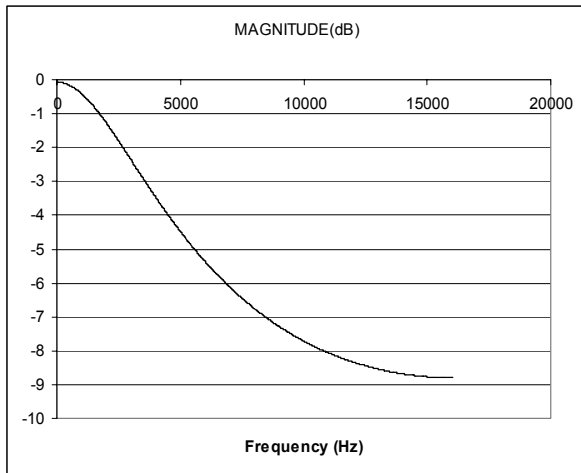

Figure 98 De-Emphasis Digital Filter Response (32kHz)

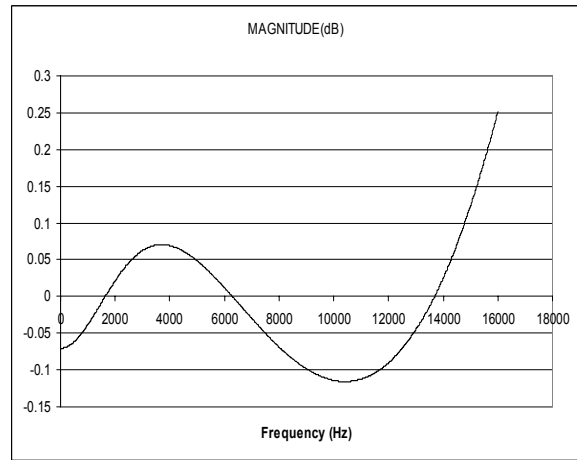

Figure 99 De-Emphasis Error (32kHz)

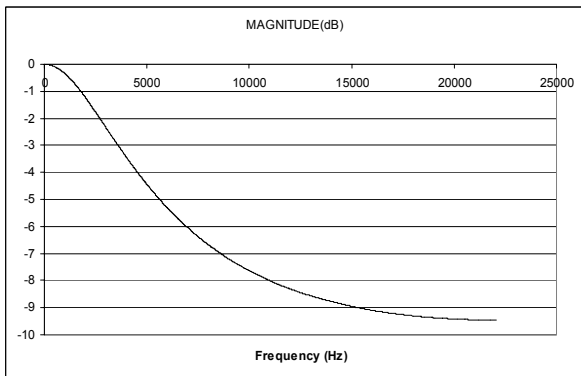

Figure 100 De-Emphasis Digital Filter Response (44.1kHz)

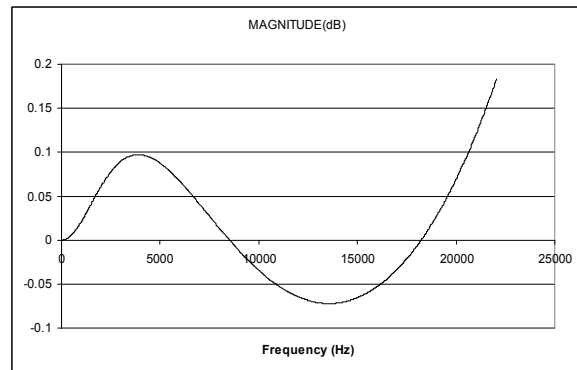

Figure 101 De-Emphasis Error (44.1kHz)

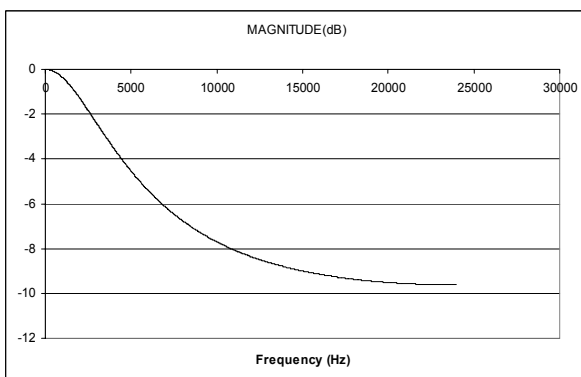

Figure 102 De-Emphasis Digital Filter Response (48kHz)

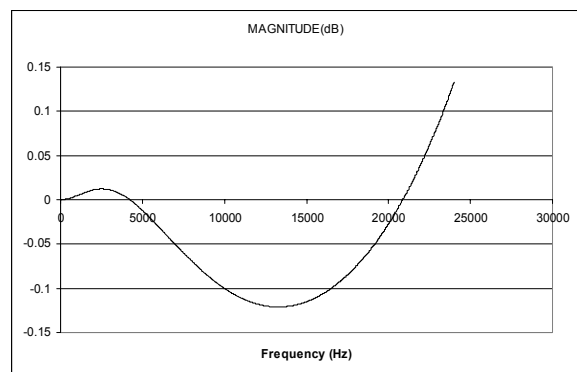
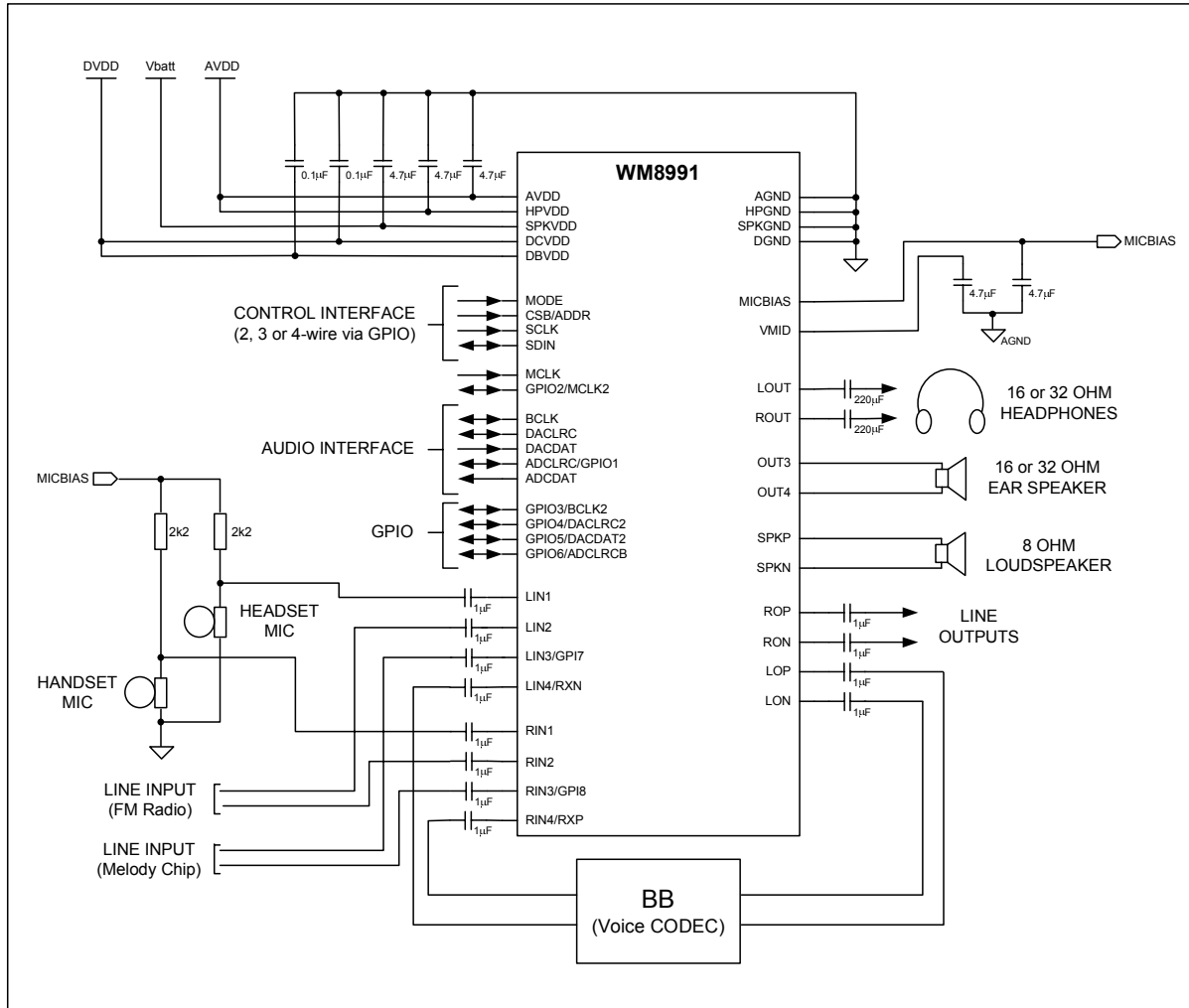

Figure 103 De-Emphasis Error (48kHz)

APPLICATIONS INFORMATION

RECOMMENDED EXTERNAL COMPONENTS



Notes:

1. Wolfson recommend using a single, common ground reference. Where this is not possible care should be taken to optimise split ground configuration for audio performance.
2. Supply decoupling capacitors on DCVDD, DBVDD, SPKVDD, HPVDD and AVDD should be positioned as close to the WM8991 as possible. Values indicated are minimum requirements.
3. Capacitor types should be carefully chosen. Capacitors with very low ESR are recommended for optimum performance.
4. The loudspeaker should be connected as close as possible to the WM8991. When this is not possible, filtering should be placed on the speaker outputs close to the WM8991.
5. The 2k2 MICBIAS resistors on each of the MIC inputs are typical values and will be suitable for many electret type microphones. However, it is recommended that engineers refer to individual microphone specifications prior to finalising the value of this component.

SPEAKER SELECTION

For filterless operation, it is important to select a speaker with appropriate internal inductance. The internal inductance and the speaker's load resistance create a low-pass filter with a cut-off frequency of:

$$f_c = R_L / 2\pi L$$

e.g. for an 8Ω speaker and required cut-off frequency of 20kHz, the speaker should be chosen to have an inductance of:

$$L = R_L / 2\pi f_c = 8\Omega / 2\pi * 20kHz = 64\mu H$$

8Ω speakers typically have an inductance in the range 20μH to 100μH. Care should be taken to ensure that the cut-off frequency of the speaker's internal filtering is low enough to prevent speaker damage. The class D outputs of the WM8991 operate at much higher frequencies than is recommended for most speakers, and the cut-off frequency of the filter should be low enough to protect the speaker.

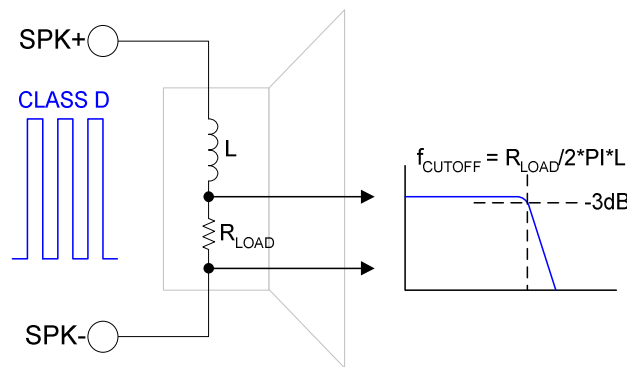

Figure 104 Speaker Equivalent Circuit

PCB LAYOUT CONSIDERATIONS

The efficiency of the speaker drivers is affected by the series resistance between the WM8991 and the speaker (e.g. inductor ESR) as shown in Figure 105. This resistance should be as low as possible to maximise efficiency.

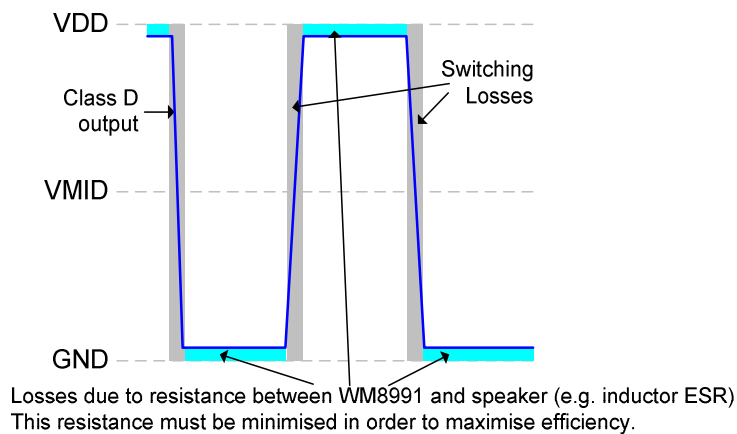

Figure 105 Speaker Connection Losses

The distance between the WM8991 and the speakers should be kept to a minimum to reduce series resistance, and also to reduce EMI. Further reductions in EMI can be achieved by additional passive filtering and/or shielding as shown in Figure 106. When additional passive filtering is used, low ESR components should be chosen to minimise series resistance between the WM8991 and the speaker, maximising efficiency.

LC passive filtering will usually be effective at reducing EMI at frequencies up to around 30MHz. To reduce emissions at higher frequencies, ferrite beads placed as close to the device as possible will be more effective.

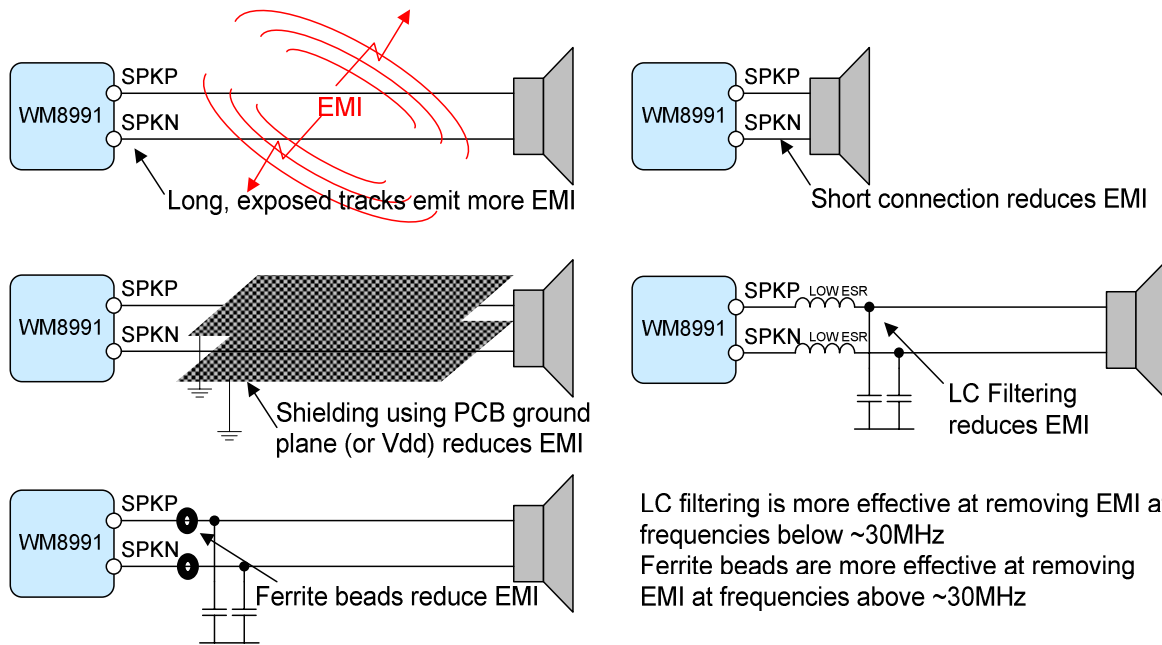
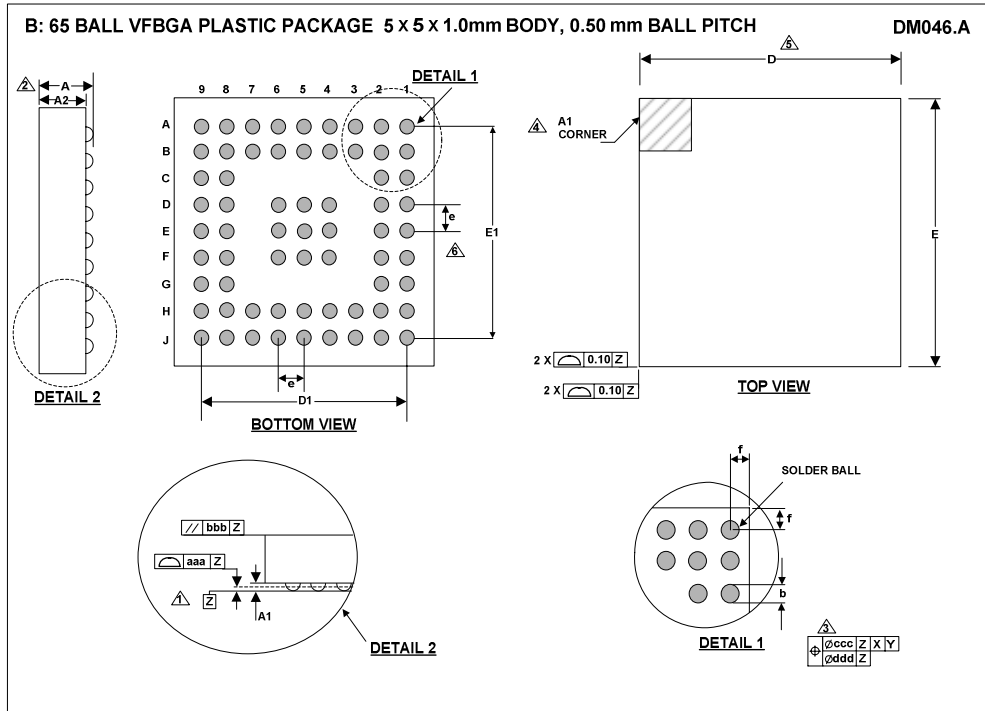

Figure 106 EMI Reduction Techniques

PACKAGE DIMENSIONS



Symbols	Dimensions (mm)			
	MIN	NOM	MAX	NOTE
A			1.0	
A1	0.15			
A2	0.65	0.70	0.75	
b	0.25	0.30	0.35	
D		5.00 BSC		
D1		4.00 BSC		
E		5.00 BSC		
E1		4.00 BSC		
e		0.50 BSC		6
f		0.50		
Tolerances of Form and Position				
aaa		0.08		
bbb		0.10		
ccc		0.15		
ddd		0.05		
REF:		JEDEC MO-225		

- NOTES:
1. PRIMARY DATUM -Z- AND SEATING PLANE ARE DEFINED BY THE SPHERICAL CROWNS OF THE SOLDER BALLS.
 2. THIS DIMENSION INCLUDES STAND-OFF HEIGHT 'A1'.
 3. DIMENSION 'b' IS MEASURED AT THE MAXIMUM SOLDER BALL DIAMETER, PARALLEL TO PRIMARY DATUM -Z-.
 4. A1 CORNER IS IDENTIFIED BY INK/LASER MARK ON TOP PACKAGE.
 5. BILATERAL TOLERANCE ZONE IS APPLIED TO EACH SIDE OF THE PACKAGE BODY.
 6. 'e' REPRESENTS THE BASIC SOLDER BALL GRID PITCH.
 7. THIS DRAWING IS SUBJECT TO CHANGE WITHOUT NOTICE.
 8. FOLLOWS JEDEC DESIGN GUIDE MO-225.

IMPORTANT NOTICE

Wolfson Microelectronics plc ("Wolfson") products and services are sold subject to Wolfson's terms and conditions of sale, delivery and payment supplied at the time of order acknowledgement.

Wolfson warrants performance of its products to the specifications in effect at the date of shipment. Wolfson reserves the right to make changes to its products and specifications or to discontinue any product or service without notice. Customers should therefore obtain the latest version of relevant information from Wolfson to verify that the information is current.

Testing and other quality control techniques are utilised to the extent Wolfson deems necessary to support its warranty. Specific testing of all parameters of each device is not necessarily performed unless required by law or regulation.

In order to minimise risks associated with customer applications, the customer must use adequate design and operating safeguards to minimise inherent or procedural hazards. Wolfson is not liable for applications assistance or customer product design. The customer is solely responsible for its selection and use of Wolfson products. Wolfson is not liable for such selection or use nor for use of any circuitry other than circuitry entirely embodied in a Wolfson product.

Wolfson's products are not intended for use in life support systems, appliances, nuclear systems or systems where malfunction can reasonably be expected to result in personal injury, death or severe property or environmental damage. Any use of products by the customer for such purposes is at the customer's own risk.

Wolfson does not grant any licence (express or implied) under any patent right, copyright, mask work right or other intellectual property right of Wolfson covering or relating to any combination, machine, or process in which its products or services might be or are used. Any provision or publication of any third party's products or services does not constitute Wolfson's approval, licence, warranty or endorsement thereof. Any third party trade marks contained in this document belong to the respective third party owner.

Reproduction of information from Wolfson datasheets is permissible only if reproduction is without alteration and is accompanied by all associated copyright, proprietary and other notices (including this notice) and conditions. Wolfson is not liable for any unauthorised alteration of such information or for any reliance placed thereon.

Any representations made, warranties given, and/or liabilities accepted by any person which differ from those contained in this datasheet or in Wolfson's standard terms and conditions of sale, delivery and payment are made, given and/or accepted at that person's own risk. Wolfson is not liable for any such representations, warranties or liabilities or for any reliance placed thereon by any person.

ADDRESS:

Wolfson Microelectronics plc
26 Westfield Road
Edinburgh
EH11 2QB
United Kingdom

Tel :: +44 (0)131 272 7000

Fax :: +44 (0)131 272 7001

Email :: sales@wolfsonmicro.com