

## General Description

The 851010 is a 1-to-10 Differential HCSL Fanout Buffer. The 851010 is designed to translate any differential signal levels to differential HCSL output levels. An external reference resistor is used to set the value of the current supplied to an external load. The load resistor value is chosen to equal the value of the characteristic line impedance of 50Ω. The 851010 is characterized at an operating supply voltage of 3.3V.

The differential HCSL outputs, accurate crossover voltage and symmetric duty cycle makes the 851010 ideal for interfacing to PCI Express and FBDIMM applications.

## Features

- Ten differential HCSL outputs
- Translates any differential input signal (LVPECL, LVHSTL, LVDS, HCSL) to HCSL levels without external bias networks
- Maximum output frequency: 250MHz
- Output skew: 165ps (maximum)
- Part-to-part skew: 250ps (maximum)
- Output drift: 140ps (maximum)
- $V_{OH}$ : 850mV (maximum)
- Full 3.3V supply voltage
- Available in lead-free (RoHS 6) package
- 0°C to 70°C ambient operating temperature

## Block Diagram

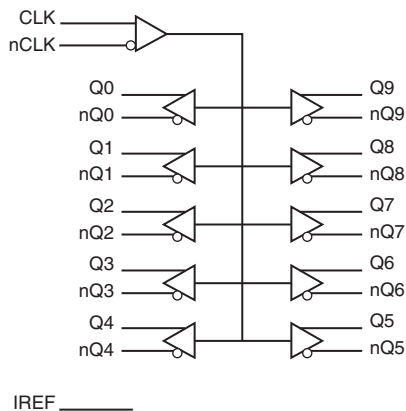

## Pin Assignment

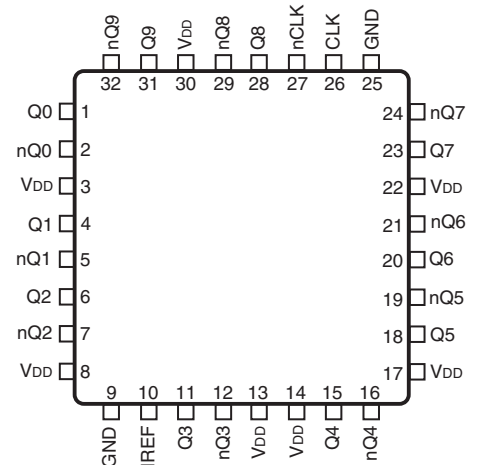

**851010**

**32-Lead LQFP**

**7mm x 7mm x 1.4mm package body**

**Y Package**

**Top View**

**Table 1. Pin Descriptions**

Number	Name	Type	Description
1, 2	Q0, nQ0	Output	Differential output pair. Differential HCSL interface levels.
3, 8, 13, 14, 17, 22, 30	V <sub>DD</sub>	Power	Positive supply pins.
4, 5	Q1, nQ1	Output	Differential output pair. Differential HCSL interface levels.
6, 7	Q2, nQ2	Output	Differential output pair. Differential HCSL interface levels.
9, 25	GND	Power	Power supply ground.
10	IREF	Input	Reference current input. Used to set the output current. Connect to 950Ω resistor to ground.
11, 12	Q3, nQ3	Output	Differential output pair. Differential HCSL interface levels.
15, 16	Q4, nQ4	Output	Differential output pair. Differential HCSL interface levels.
18, 19	Q5, nQ5	Output	Differential output pair. Differential HCSL interface levels.
20, 21	Q6, nQ6	Output	Differential output pair. Differential HCSL interface levels.
23, 24	Q7, nQ7	Output	Differential output pair. Differential HCSL interface levels.
26	CLK	Input	Non-inverting differential input.
27	nCLK	Input	Inverting differential clock input.
28, 29	Q8, nQ8	Output	Differential output pair. Differential HCSL interface levels.
31, 32	Q9, nQ9	Output	Differential output pair. Differential HCSL interface levels.

## Output Driver Current

The 851010 outputs are HCSL differential current drive with the current being set with a resistor from I<sub>REF</sub> to ground. For a *single load* and a 50Ω pc board trace, the drive current would typically be set with a R<sub>REF</sub> of 950Ω which produces an I<sub>REF</sub> of 1.16mA. The I<sub>REF</sub> is multiplied by a current mirror to an output drive of 12\*1.16mA or 13.90mA. See *Figure 1* for current mirror and output drive details.

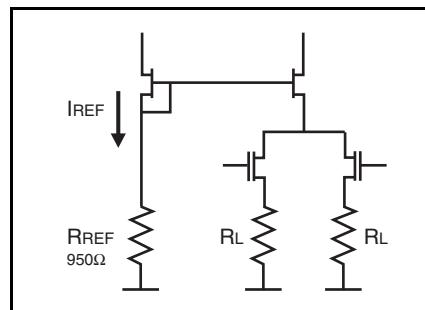
**Figure 1. HCSL Current Mirror and Output Drive**

## Absolute Maximum Ratings

NOTE: Stresses beyond those listed under *Absolute Maximum Ratings* may cause permanent damage to the device. These ratings are stress specifications only. Functional operation of product at these conditions or any conditions beyond those listed in the *DC Characteristics* or *AC Characteristics* is not implied. Exposure to absolute maximum rating conditions for extended periods may affect product reliability.

Item	Rating
Supply Voltage, $V_{DD}$	4.6V
Inputs, $V_I$	-0.5V to $V_{DD} + 0.5V$
Outputs, $I_O$	-0.5V to $V_{DD} + 0.5V$
Package Thermal Impedance, $\theta_{JA}$	65.7°C/W (0 mps)
Storage Temperature, $T_{STG}$	-65°C to 150°C

## DC Electrical Characteristics

**Table 2A. Power Supply DC Characteristics,  $V_{DD} = 3.3V \pm 5\%$ ,  $T_A = 0^\circ C$  to  $70^\circ C$**

Symbol	Parameter	Test Conditions	Minimum	Typical	Maximum	Units
$V_{DD}$	Core Supply Voltage		3.135	3.3	3.465	V
$I_{DD}$	Power Supply Current; NOTE 1				105	mA

NOTE 1: Measured using 200MHz input frequency.

**Table 2B. Differential DC Characteristics,  $V_{DD} = 3.3V \pm 5\%$ ,  $T_A = 0^\circ C$  to  $70^\circ C$**

Symbol	Parameter		Test Conditions	Minimum	Typical	Maximum	Units
$I_{IH}$	Input High Current	CLK, nCLK	$V_{DD} = V_{IN} = 3.465V$			5	$\mu A$
$I_{IL}$	Input Low Current	CLK, nCLK	$V_{DD} = 3.465V, V_{IN} = 0V$			5	$\mu A$
$V_{PP}$	Peak-to-Peak Voltage; NOTE 1			0.15		1.3	V
$V_{CMR}$	Common Mode Input Voltage; NOTE 1, 2			GND + 0.5		$V_{DD} - 0.85$	V

NOTE 1:  $V_{IL}$  should not be less than -0.3V.

NOTE 2: Common mode input voltage is defined as  $V_{IH}$ .

## AC Electrical Characteristics

**Table 3. HCSL AC Characteristics,  $V_{DD} = 3.3V \pm 5\%$ ,  $T_A = 0^\circ C$  to  $70^\circ C$**

Symbol	Parameter	Test Conditions	Minimum	Typical	Maximum	Units
$f_{MAX}$	Output Frequency				250	MHz
$t_{PD}$	Propagation Delay; NOTE 1	Measured on at $V_{OX}$	1.5		2.75	ns
$t_{sk(o)}$	Output Skew; NOTE 2, 3	Measured on at $V_{OX}$			165	ps
$t_{sk(pp)}$	Part-to-Part Skew; NOTE 3, 4				250	ps
$f_{jit}$	Buffer Additive Phase Jitter, RMS	CLK = 200MHz, Integration Range: 12kHz – 30MHz		0.24		ps
$t_{sk(drift)}$	Output Drift; NOTE 5				140	ps
$V_{MAX}$	Absolute Max Output Voltage; NOTE 6	$f \leq 150MHz$	500		850	mV
$V_{MIN}$	Absolute Min Output Voltage; NOTE 6	$f \leq 150MHz$	-150		150	mV
$V_{CROSS}$	Absolute Crossing Voltage; NOTE 7, 8, 9		250		550	mV
$\Delta V_{CROSS}$	Total Variation of $V_{CROSS}$ over all edges; NOTE 7, 8, 10				140	mV
$t_R / t_F$	Rise/Fall Edge Rate; NOTE 11, 12		0.6		4.0	V/ns
odc	Output Duty Cycle; NOTE 13		47		53	%

**NOTE:** Electrical parameters are guaranteed over the specified ambient operating temperature range, which is established when the device is mounted in a test socket with maintained transverse airflow greater than 500 lpm. The device will meet specifications after thermal equilibrium has been reached under these conditions.

**NOTE:** Current adjust set for  $V_{OH} = 0.7V$ . Measurements refer to PCIEX outputs only.

**NOTE:** Characterized using an  $R_{REF}$  value of  $950\Omega$  resistor.

**NOTE 1:** Measured from the differential input cross point to the differential output crossing point.

**NOTE 2:** Defined as skew between outputs at the same supply voltage and with equal load conditions. Measured at the differential output cross point.

**NOTE 3:** This parameter is defined in accordance with JEDEC Standard 65.

**NOTE 4:** Defined as skew between outputs on different devices operating at the same supply voltage, same frequency, same temperature and with equal load conditions. Using the same type of inputs on each device, the outputs are measured at the differential cross point.

**NOTE 5:** Output Drift is measured as the change in the time placement of the differential cross point for each output on a given device due to a change in temperature and supply voltage. Measured at the differential cross point.

**NOTE 6:** Measurement using  $R_{REF} = 950\Omega$ ,  $R_{LOAD} = 50\Omega$ .

**NOTE 7:** Measurement taken from single-ended waveform.

**NOTE 8:** Measured at crossing point where the instantaneous voltage value of the rising edge of  $Q_x$  equals the falling edge of  $nQ_x$ .

See Parameter Measurement Information Section.

**NOTE 9:** Refers to the total variation from the lowest crossing point to the highest, regardless of which edge is crossing. Refers to all crossing points for this measurement. See Parameter Measurement Information Section.

**NOTE 10:** Defined as the total variation of all crossing voltage of rising  $Q_x$  and falling  $nQ_x$ . This is the maximum allowed variance in the  $V_{CROSS}$  for any particular system. See Parameter Measurement Information Section.

**NOTE 11:** Measurement taken from differential waveform.

**NOTE 12:** Measurement from -150mV to +150mV on the differential waveform (derived from  $Q_x$  minus  $nQ_x$ ). The signal must be monotonic through the measurement region for rise and fall time. The 300mV measurement window is centered on the differential zero crossing.

**NOTE 13:** Assuming 50% input duty cycle. Data taken at  $f \leq 200MHz$ , unless otherwise specified.

### Parameter Measurement Information

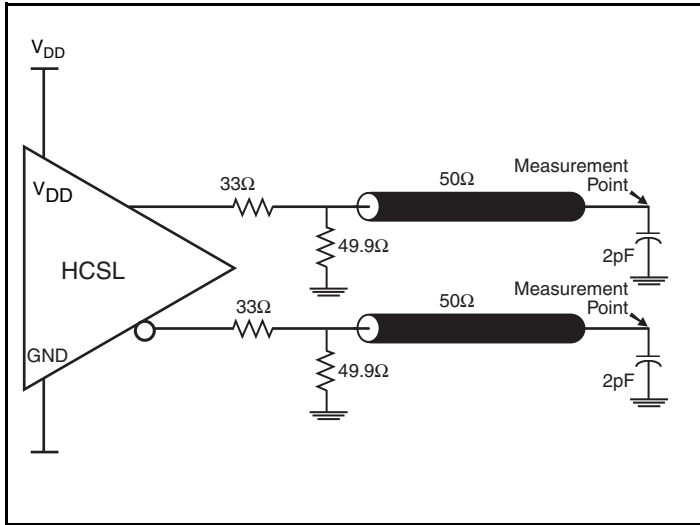

HCSL Output Load AC Test Circuit

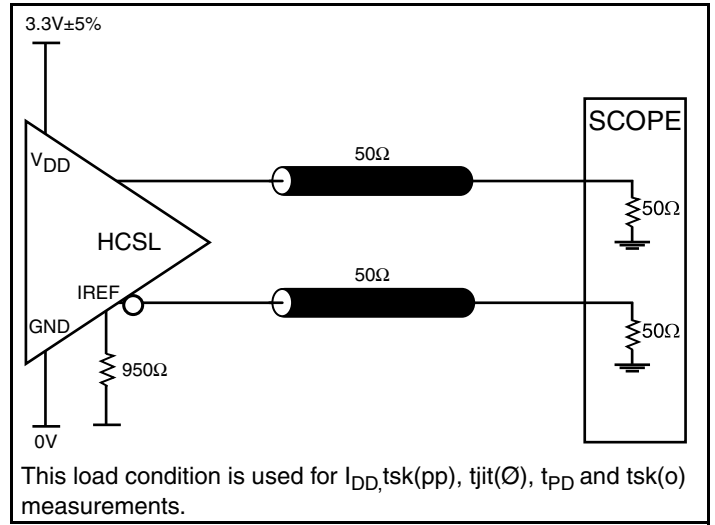

HCSL Output Load AC Test Circuit

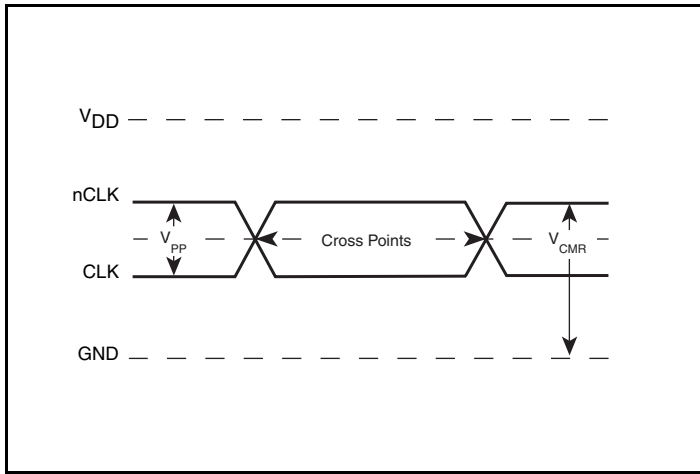

Differential Input Levels

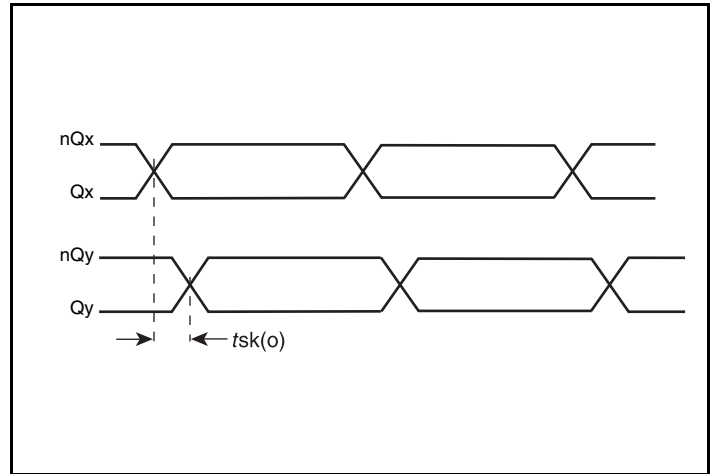

Output Skew

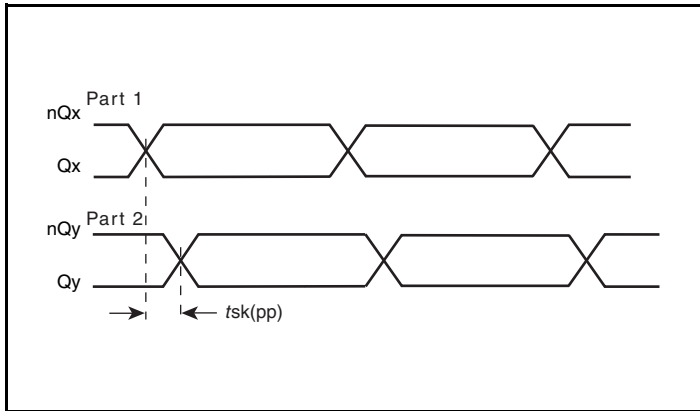

Part-to-Part Skew

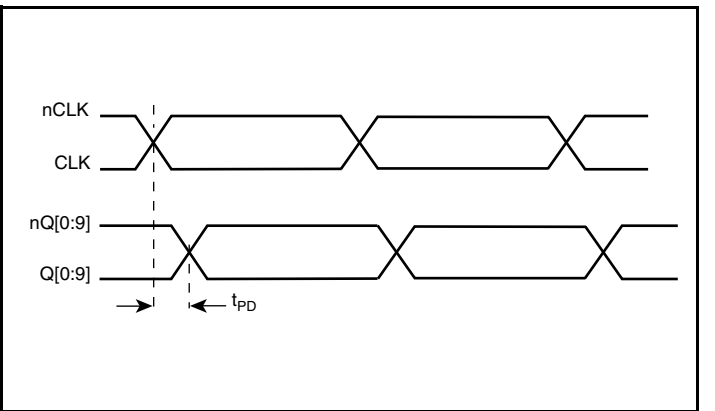

Propagation Delay

## Parameter Measurement Information, continued

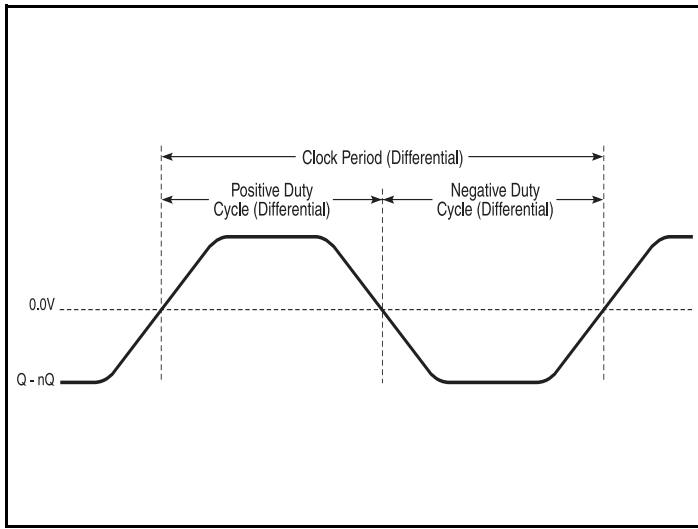

Differential Measurement Points for Duty Cycle/Period

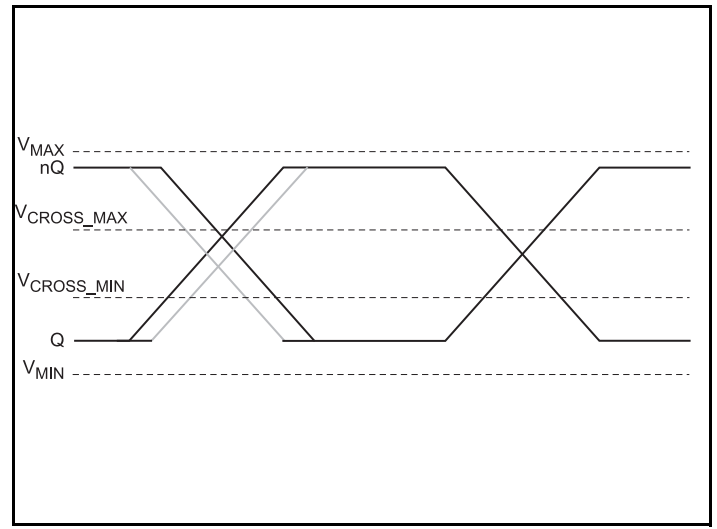

Single-ended Measurement Points for Absolute Cross Point and Swing

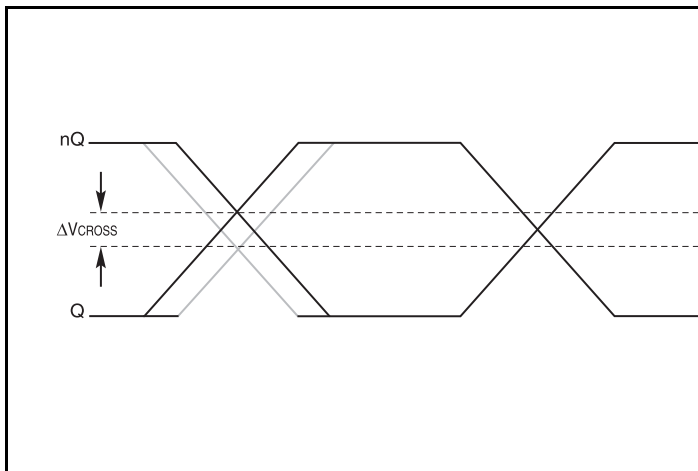

Single-ended Measurement Points for Delta Cross Point

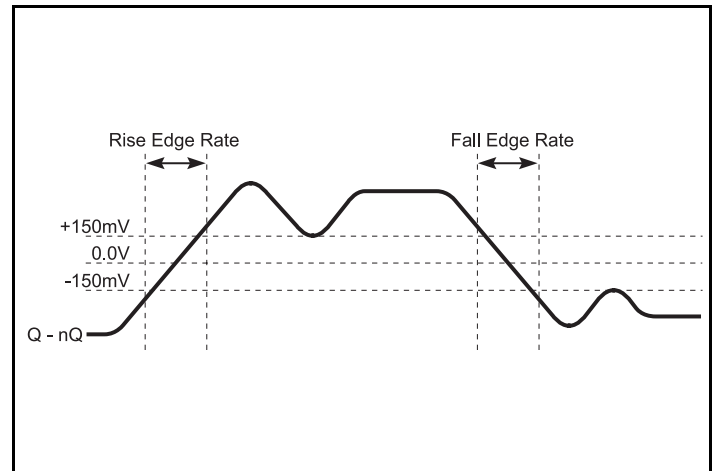

Differential Measurement Points for Rise/Fall Edge Rate

## Applications Information

### Recommendations for Unused Output Pins

#### Outputs:

##### Differential Outputs

All unused differential outputs can be left floating. We recommend that there is no trace attached. Both sides of the differential output pair should either be left floating or terminated.

### Wiring the Differential Input to Accept Single-Ended Levels

Figure 2 shows how a differential input can be wired to accept single ended levels. The reference voltage  $V_{REF} = V_{DD}/2$  is generated by the bias resistors R1 and R2. The bypass capacitor (C1) is used to help filter noise on the DC bias. This bias circuit should be located as close to the input pin as possible. The ratio of R1 and R2 might need to be adjusted to position the  $V_{REF}$  in the center of the input voltage swing. For example, if the input clock swing is 2.5V and  $V_{DD} = 3.3V$ , R1 and R2 value should be adjusted to set  $V_{REF}$  at 1.25V. The values below are for when both the single ended swing and  $V_{DD}$  are at the same voltage. This configuration requires that the sum of the output impedance of the driver ( $R_o$ ) and the series resistance ( $R_s$ ) equals the transmission line impedance. In addition, matched termination at the input will attenuate the signal in half. This can be done in one of two ways. First, R3 and R4 in parallel should equal the transmission

line impedance. For most 50Ω applications, R3 and R4 can be 100Ω. The values of the resistors can be increased to reduce the loading for slower and weaker LVCMOS driver. When using single-ended signaling, the noise rejection benefits of differential signaling are reduced. Even though the differential input can handle full rail LVCMOS signaling, it is recommended that the amplitude be reduced. The datasheet specifies a lower differential amplitude, however this only applies to differential signals. For single-ended applications, the swing can be larger, however  $V_{IL}$  cannot be less than -0.3V and  $V_{IH}$  cannot be more than  $V_{DD} + 0.3V$ . Though some of the recommended components might not be used, the pads should be placed in the layout. They can be utilized for debugging purposes. The datasheet specifications are characterized and guaranteed by using a differential signal.

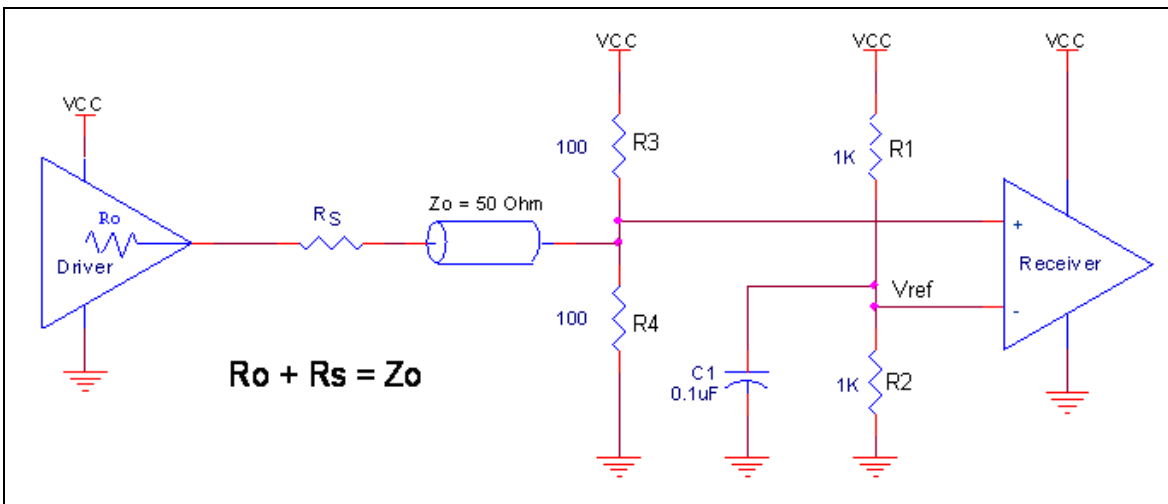
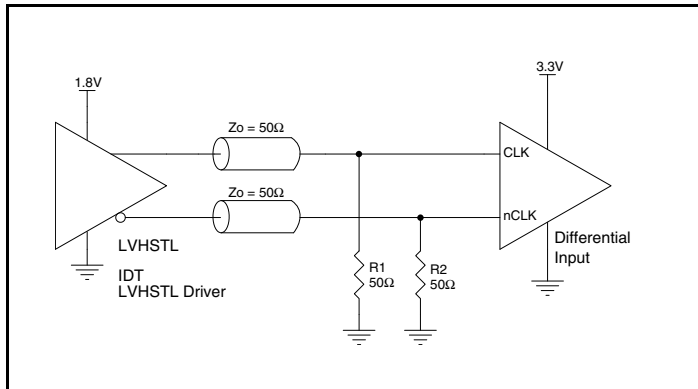

Figure 2. Recommended Schematic for Wiring a Differential Input to Accept Single-ended Levels

## Differential Clock Input Interface

The CLK/nCLK accepts HCSL, LVDS, LVPECL and SSTL and other differential signals. Both differential signals must meet the  $V_{PP}$  and  $V_{CMR}$  input requirements. *Figures 3A to 3F* show interface examples for the CLK/nCLK input driven by the most common driver types. The input interfaces suggested here are examples only. Please consult

with the vendor of the driver component to confirm the driver termination requirements. For example in Figure 3A, the input termination applies for IDT open emitter LVHSTL drivers. If you are using an LVHSTL driver from another vendor, use their termination recommendation.



**Figure 3A.** CLK/nCLK Input Driven by an IDT Open Emitter LVHSTL Driver

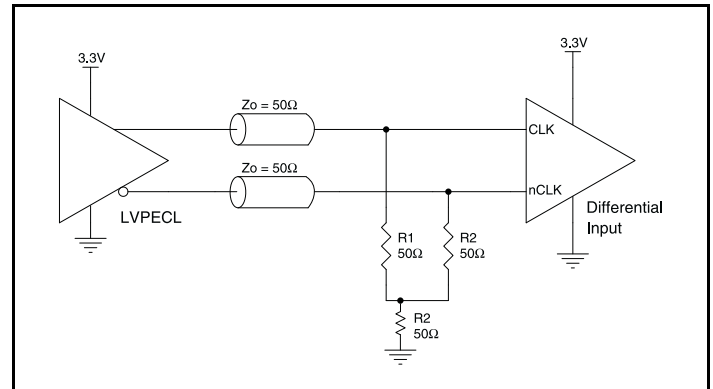

**Figure 3B.** CLK/nCLK Input Driven by a 3.3V LVPECL Driver

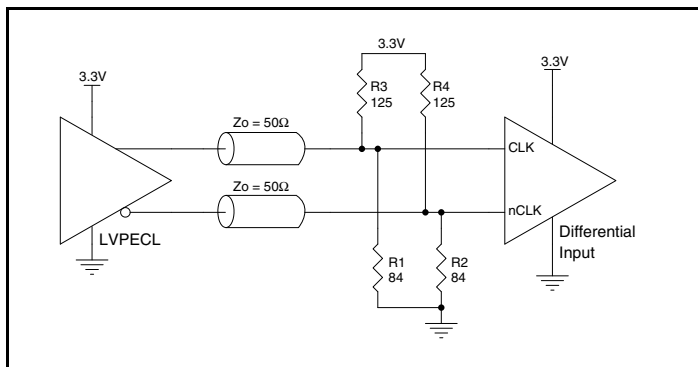

**Figure 3C.** CLK/nCLK Input Driven by a 3.3V LVPECL Driver

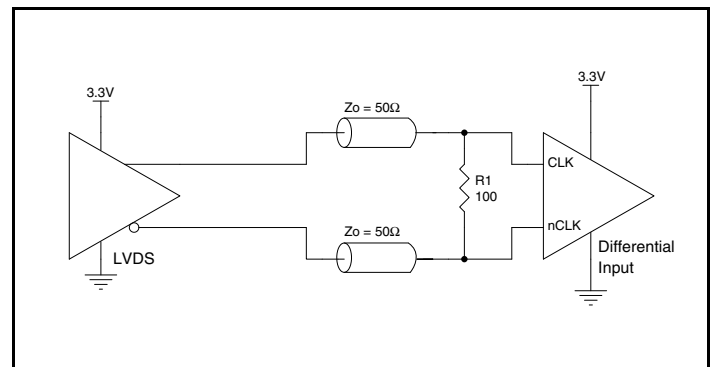

**Figure 3D.** CLK/nCLK Input Driven by a 3.3V LVDS Driver

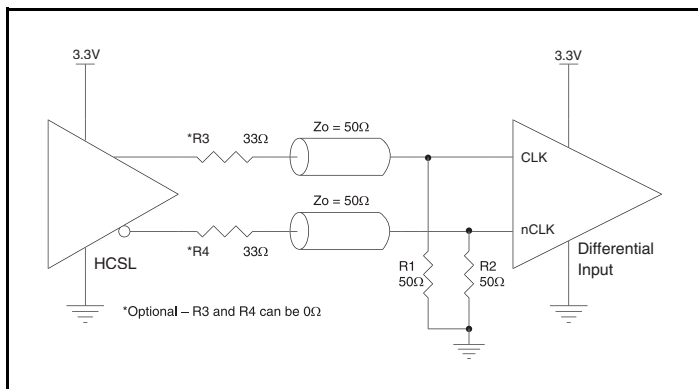

**Figure 3E.** CLK/nCLK Input Driven by a 3.3V HCSL Driver

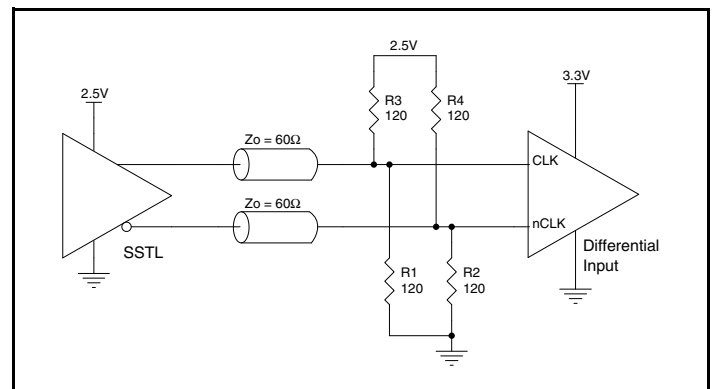

**Figure 3F.** CLK/nCLK Input Driven by an SSTL Driver



### Recommended Termination

Figure 4A is the recommended termination for applications which require the receiver and driver to be on a separate PCB. All traces should be 50Ω impedance.

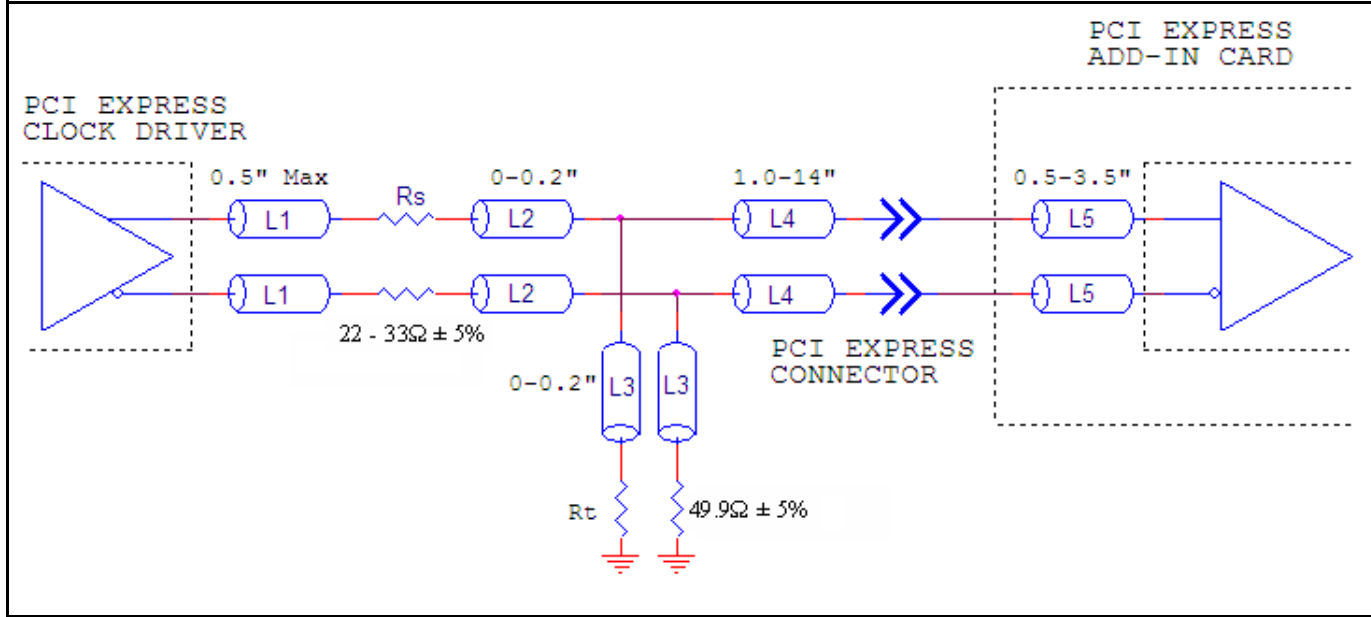

Figure 4A. Recommended Termination

Figure 4B is the recommended termination for applications which require a point to point connection and contain the driver and receiver on the same PCB. All traces should all be 50Ω impedance.

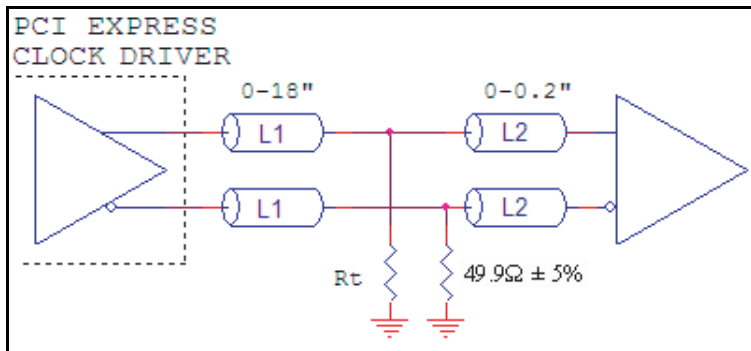

Figure 4B. Recommended Termination

## Power Considerations

This section provides information on power dissipation and junction temperature for the 851010. Equations and example calculations are also provided.

### 1. Power Dissipation.

The total power dissipation for the 851010 is the sum of the core power plus the power dissipated in the load(s). The following is the power dissipation for  $V_{DD} = 3.3V + 5\% = 3.465V$ , which gives worst case results.

- Power (core)<sub>MAX</sub> =  $V_{DD\_MAX} * I_{DD\_MAX} = 3.465V * 105mA = \mathbf{363.825mW}$
- Power (outputs)<sub>MAX</sub> = **44.5mW/Loaded Output Pair**  
If all outputs are loaded, the total power is  $10 * 44.5mW = \mathbf{445mW}$

**Total Power**<sub>MAX</sub> (3.465V, with all outputs switching) =  $363.825mW + 445mW = \mathbf{808.825mW}$

### 2. Junction Temperature.

Junction temperature,  $T_j$ , is the temperature at the junction of the bond wire and bond pad directly affects the reliability of the device. The maximum recommended junction temperature is 125°C. Limiting the internal transistor junction temperature,  $T_j$ , to 125°C ensures that the bond wire and bond pad temperature remains below 125°C.

The equation for  $T_j$  is as follows:  $T_j = \theta_{JA} * Pd\_total + T_A$

$T_j$  = Junction Temperature

$\theta_{JA}$  = Junction-to-Ambient Thermal Resistance

$Pd\_total$  = Total Device Power Dissipation (example calculation is in section 1 above)

$T_A$  = Ambient Temperature

In order to calculate junction temperature, the appropriate junction-to-ambient thermal resistance  $\theta_{JA}$  must be used. Assuming no air flow and a multi-layer board, the appropriate value is 65.7°C/W per Table 4 below.

Therefore,  $T_j$  for an ambient temperature of 70°C with all outputs switching is:

$$70^\circ\text{C} + 0.809\text{W} * 65.7^\circ\text{C/W} = 123.2^\circ\text{C}. \text{ This is below the limit of } 125^\circ\text{C}.$$

This calculation is only an example.  $T_j$  will obviously vary depending on the number of loaded outputs, supply voltage, air flow and the type of board (multi-layer).

**Table 4. Thermal Resistance  $\theta_{JA}$  for 32 Lead LQFP, Forced Convection**

$\theta_{JA}$ by Velocity			
Meters per Second	0	1	2.5
Multi-Layer PCB, JEDEC Standard Test Boards	65.7°C/W	55.9°C/W	52.4°C/W

The purpose of this section is to calculate power dissipation on the IC per HCSL output pair.

HCSL output driver circuit and termination are shown in *Figure 5*.

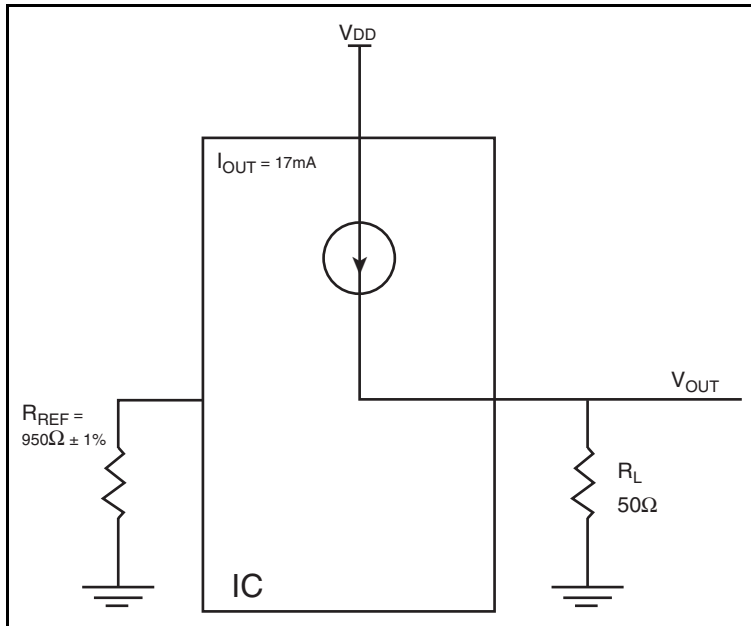

**Figure 5. HCSL Driver Circuit and Termination**

HCSL is a current steering output which sources a maximum of 17mA of current per output. To calculate worst case on-chip power dissipation, use the following equations which assume a 50Ω load to ground.

The highest power dissipation occurs when  $V_{DD\_MAX}$ .

$$\text{Power} = (V_{DD\_MAX} - V_{OUT}) * I_{OUT}$$

$$\text{since } V_{OUT} = I_{OUT} * R_L$$

$$= (V_{DD\_MAX} - I_{OUT} * R_L) * I_{OUT}$$

$$= (3.465V - 17mA * 50\Omega) * 17mA$$

Total Power Dissipation per output pair = **44.5mW**

## Reliability Information

**Table 5.  $\theta_{JA}$  vs. Air Flow Table for a 32 Lead LQFP**

$\theta_{JA}$ vs. Air Flow			
Meters per Second	0	1	2.5
Multi-Layer PCB, JEDEC Standard Test Boards	65.7°C/W	55.9°C/W	52.4°C/W

## Transistor Count

The transistor count for 851010 is: 843

## Package Outline and Package Dimensions

### Package Outline - Y Suffix for 32 Lead LQFP

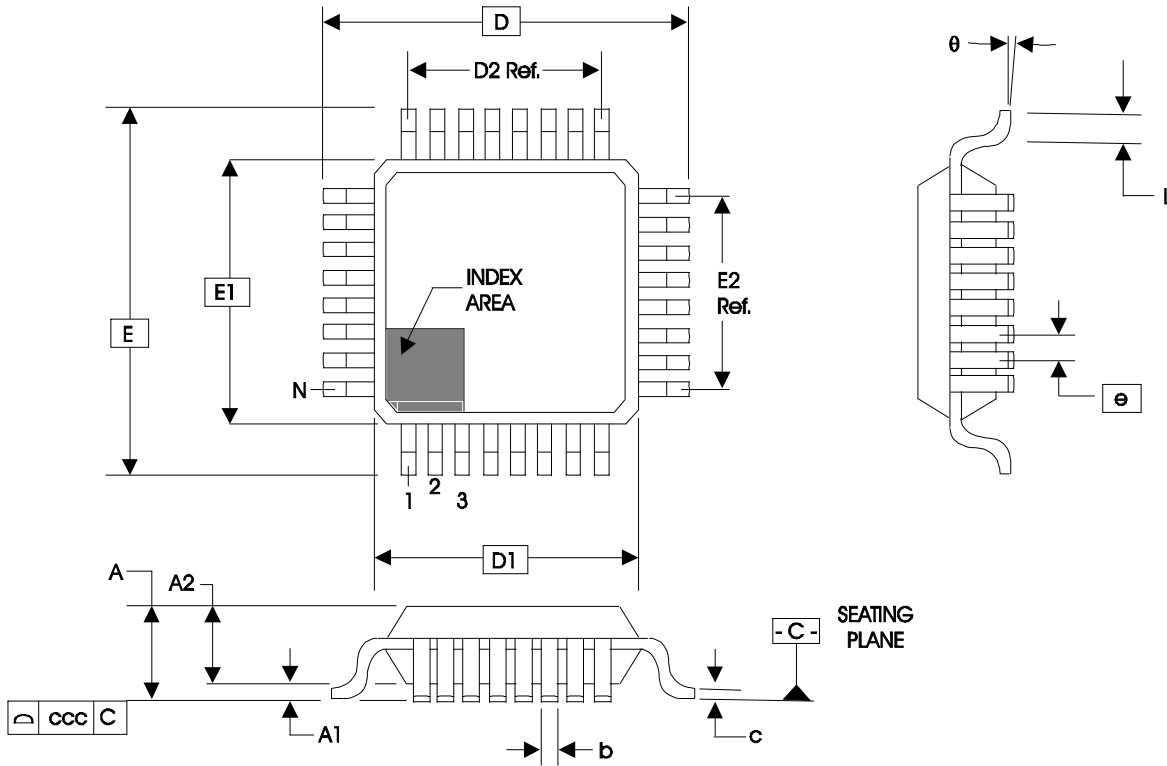

Table 6. Package Dimensions for 32 Lead LQFP

JEDEC Variation: BBA			
All Dimensions in Millimeters			
Symbol	Minimum	Nominal	Maximum
N	32		
A			1.60
A1	0.05		0.15
A2	1.35	1.40	1.45
b	0.30	0.37	0.45
c	0.09		0.20
D & E	9.00 Basic		
D1 & E1	7.00 Basic		
D2 & E2	5.60 Ref.		
e	0.80 Basic		
L	0.45	0.60	0.75
$\theta$	0°		7°
ccc			0.10

Reference Document: JEDEC Publication 95, MS-026

## Ordering Information

Table 7. Ordering Information

Part/Order Number	Marking	Package	Shipping Packaging	Temperature
851010AYLF	ICS851010AYL	Lead-Free, 32 Lead LQFP	Tray	0°C to 70°C
851010AYLFT	ICS851010AYL	Lead-Free, 32 Lead LQFP	Tape & Reel	0°C to 70°C

## Revision History Sheet

Rev	Table	Page	Description of Change	Date
A	T1	2	Pin Description Table, IREF description corrected 475ohm resistor to 950ohm.	8/2/10
		2	Corrected <i>Output Driver Current and diagram</i> .	
	T3	4	Added note, "Characterized using...".	
		5	Added <i>Propagation Delay</i> diagram and corrected <i>HCSL Output Load AC Test Circuit</i> diagram in Parameter Measurement Information section.	
		7	Updated <i>Wiring the Differential Input to Accept Single-ended Levels</i> .	
		10 -11	Corrected power dissipation calculation and total power dissipation section. Corrected <i>HCSL Driver Circuit Termination</i> diagram.	
		13	Updated <i>Package Outline</i> . Converted datasheet format.	
A	T7	14	Ordering Information - removed leaded devices. Removed the Lead Free note and the quantity (1000) in the shipping packaging field. Updated datasheet format.	12/3/15



Corporate Headquarters  
6024 Silver Creek Valley Road  
San Jose, CA 95138 USA  
[www.IDT.com](http://www.IDT.com)

Sales  
1-800-345-7015 or 408-284-8200  
Fax: 408-284-2775  
[www.IDT.com/go/sales](http://www.IDT.com/go/sales)

Tech Support  
[www.idt.com/go/support](http://www.idt.com/go/support)

DISCLAIMER Integrated Device Technology, Inc. (IDT) reserves the right to modify the products and/or specifications described herein at any time, without notice, at IDT's sole discretion. Performance specifications and operating parameters of the described products are determined in an independent state and are not guaranteed to perform the same way when installed in customer products. The information contained herein is provided without representation or warranty of any kind, whether express or implied, including, but not limited to, the suitability of IDT's products for any particular purpose, an implied warranty of merchantability, or non-infringement of the intellectual property rights of others. This document is presented only as a guide and does not convey any license under intellectual property rights of IDT or any third parties.

IDT's products are not intended for use in applications involving extreme environmental conditions or in life support systems or similar devices where the failure or malfunction of an IDT product can be reasonably expected to significantly affect the health or safety of users. Anyone using an IDT product in such a manner does so at their own risk, absent an express, written agreement by IDT.

Integrated Device Technology, IDT and the IDT logo are trademarks or registered trademarks of IDT and its subsidiaries in the United States and other countries. Other trademarks used herein are the property of IDT or their respective third party owners.

For datasheet type definitions and a glossary of common terms, visit [www.idt.com/go/glossary](http://www.idt.com/go/glossary).

Copyright ©2015 Integrated Device Technology, Inc. All rights reserved.