



# Current Sensing Resistors

Chip Current Sense / Open-Air Current Shunts /  
Axial Current Sense Resistors

## Token Electronics Industry Co., Ltd.

**Taiwan:** No. 137, Sec. 1, Chung Shin Rd., Wu Ku Hsiang, Taipei Hsien, Taiwan, R.O.C  
TEL: 886-2-2981 0109; FAX: 886-2-2988 7487

**China:** 12F, Zhongxing Industry Bld., Chuangye Rd., Nanshan District, Shenzhen, Guangdong  
TEL: 86-755-2605 5363, 2605 5364; FAX: 86-755-2605 5365



<http://www.token.com.tw>



[rfq@token.com.tw](mailto:rfq@token.com.tw)

# Product Index

## Information

● General Information -----	01
● Design & Selection -----	03
● Terminology & Glossary -----	05

## Chip Current Sense Resistors

● LRC Series - Current Sense Metal Strip Chip Resistors -----	08
● CS Series - Surface Mount Current Detecting Resistors -----	13
● TCS Series - Thin Film Current Sensing Chips -----	21

## Open-Air Current Shunts

● LRA Series - Open Air Low Ohmic Resistors -----	26
● LRB Series - Open Air Low Inductance -----	29
● OAR Series - Open-Air Metal Element Current Sense -----	32
● FL Series - Current Shunt Resistors -----	35
● LSQ Series - Kelvin Four Terminal Resistors -----	42
● LRD Series - Open-Air Four Leads Resistors -----	46
● LPS Series - Low Ohm Current Sense for Shunts -----	49

## Open-Air Current Shunts

● BWL Series - Power Low Resistance Resistors -----	52
● NE Series - Low Ohmic Extra Precision Resistors -----	54

Notice: Specification Changed or Version Updated will be posted at irregular intervals.  
All Updated and Final Specifications, Please Confirm with TOKEN ELECTRONICS REPRESENTATIVES.

✉ : [rfq@token.com.tw](mailto:rfq@token.com.tw)

🏠 : <http://www.token.com.tw>

# Information of Current Sensing Resistors

## You Current Options - Token Current Sense

As the world becomes more and more technology-driven, the uses for current sensing resistors will continue to increase. The need for even lower resistance value ranges is already becoming evident, as is the need for these resistors to handle more power. The industry-wide trend is the emergence of smaller and smaller products.

Token Electronics offers a wide variety of current sensing products from the industry to military standards, such as current sense in Thin-Film / Thick-Film Technology, Bare Element Resistors, and Open Air Shunts. This enables Token to present an astounding number of possible solutions for any circuit design needs.

## Applications of Current Detecting Resistors

Token's TCS and CS Series unique form factor provides automotive designers with several advantages. Both TCS and CS Series are ideal for applications involving window lift motors, fuel pump systems, seat belt pretensioners, and pulsewidth modulator feedback.

The wider resistive element and lower resistance enables higher current to pass through the device. Token's LRC ultra low ohmic metal strip chip series provides the inherent ability to flex slightly and offers stress relief during extreme temperature cycling on typical or metal substrates. This LRC series is suitable for switch power supply applications (DC-DC Converter, Charger, Adaptor) and power management of monitor.

The open air design of bare element resistor LRA and LRB Series provide a far cooler operation by allowing more air flow under the resistive element to keep excess heat from being transmitted to the PC board. They are suitable for high power AC/DC detection of power supply circuit.

Token axial moulded BWL series provides power rating up to 10 watts and lower resistance 0.005Ω, is ideal for all types of current sensing applications including switching and linear power supplies, instruments and power amplifiers.

## **PDF Catalogue Download**

Token standard current sensing resistors can be replacement for Vishay, IRC, Ohmite, KOA, Yageo devices with fast delivery and more competitive price. Contact us with your specific needs. Download Low Ohmic Current Sense Catalogue in PDF file (367KB).

Generally, a resistor manufacturer will offer their most popular devices as standards creating a reference for Engineers to design from. Typically, and especially true in the Current Sensing category, a standard device is available for most common applications. However, for applications requiring parameters that are not currently considered industry standards, Token is uniquely equipped to offer design and development services at comparatively lower costs than our competitors. In this case, the following information is required to effectively design a current sensing resistor:

# Design & Select Current Sense Resistors

## Point 1 - Power Rating

Calculate the power dissipation under operating conditions

**Equation:**  $P_{avg} = I_{RMS}^2 \times R$ ; where Power (P), Current (I), Root Mean Square (RMS), Resistance (R). Allowing for transient or fault conditions and high ambient temperature if applicable, select the required power rating. For many current sense products, only the maximum temperature of the solder joints limits the power rating. Power rating is thus a function of the PCB layout design as well as of component selection (see point 4.).

## Point 2 - Resistance Value

Determine the minimum suitable resistance value. This is the lowest value of peak sense voltage consistent with an acceptable signal to noise ratio, divided by the peak current to be measured.

## Point 3 - Temperature Coefficient of Resistance (TCR)

Establish the accuracy needed in terms of a tolerance on the value and of sensitivity to temperature. The latter factor is quoted as Temperature Coefficient of Resistance (TCR), defined as the value change in parts per million for a 1°C temperature rise. It is generally higher for low value resistors because the metallic leads or terminations, which have a very high TCR, make up a significant part of the total resistance value.

To achieve acceptable accuracy it is normally necessary to make four-terminal (Kelvin) connections to the resistor. This means connecting the current carrying tracks and the voltage sense tracks directly to the component pads. Even when this is done, there is still some pad area and solder in series with the resistor, which may compromise the actual tolerance and TCR of the soldered part. For very high accuracy or very low values, a four-terminal resistor type is the best choice.

## Point 4 - PCB Layout

Care must be taken when laying out a PCB if the stated performance of a sense resistor is to be achieved. The current carrying tracks should be as wide as possible, using multiple layers connected by many vias near the component pad. This also improves the heatsinking of the joints.

The best way to make four-terminal connections to a two-terminal through-hole resistor is to use different sides of the PCB for the current and voltage connections. Failing this, current and voltage tracks should connect to opposite sides of the component pad.

In order to avoid interference from stray magnetic fields, the loop area contained by the sense resistor, the voltage sense tracks and the sense circuit input should be minimised. This means keeping the sense circuitry as close as possible to the sense resistor and running the voltage sense tracks close to each other.

## **Point 5 - High Frequency Applications**

Where transient or AC currents involving high frequencies are to be sensed, the self-inductance of the resistor must be minimised. Wirewound or spiralled film parts should be avoided, in favour of bulk metal or low value chips.

## **Point 6 - High Heat Dissipation**

When using a metallic element shunt with high heat dissipation and low sense voltage, consideration may need to be given to thermoelectric voltages. The junction between a metallic resistance element and metal terminations acts as a thermocouple, generating a voltage proportional to the temperature difference across it.

A leaded metallic element sense resistor is therefore like two thermocouples back to back. This means that, if the temperature differences across both junctions are equal, the error voltage is cancelled out. This is achieved by making the design thermally symmetrical, namely, by presenting both terminals with similar heatsinking and by keeping any other heat sources thermally distant.

# Terminology Glossary of Current Sensing Resistors

## What is a Current Sensing Resistor

Current sensing products are the newest and fastest growing resistive products in the industry today. As with most passive products, the majority of new designs are surface mount. These resistors are used to monitor the current in a circuit and translate the amount of current in that circuit into a voltage that can be easily measured and monitored.

## Current Detecting Resistors

Due to the increase in sales of notebook PCs, the demand for the DC/DC converter has shown rapid growth because of its high-energy conversion efficiency, and its precise current-limiting capability. However, to ensure the performance of the multiple output DC/DC converter, the current limiting voltage must be detected precisely to protect an expensive notebook PC from an overload, which is generally due to shorts within the capacitors used in these devices.

For high-energy conversion efficiency various control ICs have been developed that utilize resistive components. To achieve the perfect cutoff mode of the DC load current at the programmed current-limiting voltage of the control IC, a very stable and accurate sense resistor with the following characteristics is required for precise voltage comparison.

- Very Low Ohmic Value should be below 25m $\Omega$  for minimizing power consumption at the current sensing resistor.
- Tight Tolerance must be  $\pm 1\%$  or tighter for maximizing the current supply within the limit of acceptable current.
- Low TCR is required for current sensing across the ambient temperature range of 0°C to 60°C.
- Low Thermal EMF for an accurate comparison between the programmed current-limiting voltage of the control IC and the detected voltage.

Furthermore, the self-inductance should be for high frequency applications. Recommended types are general purpose current sensing products or a flame retardant type.

## What is a Current Sensing Resistor

Current sensing products are the newest and fastest growing resistive products in the industry today. As with most passive products, the majority of new designs are surface mount. These resistors are used to monitor the current in a circuit and translate the amount of current in that circuit into a voltage that can be easily measured and monitored.

## Current Detecting Resistors

Due to the increase in sales of notebook PCs, the demand for the DC/DC converter has shown rapid growth because of its high-energy conversion efficiency, and its precise current-limiting capability. However, to ensure the performance of the multiple output DC/DC converter, the current limiting voltage must be detected precisely to protect an expensive notebook PC from an overload, which is generally due to shorts within the capacitors used in these devices.

For high-energy conversion efficiency various control ICs have been developed that utilize resistive components. To achieve the perfect cutoff mode of the DC load current at the programmed current-limiting voltage of the control IC, a very stable and accurate sense resistor with the following characteristics is required for precise voltage comparison.

- Very Low Ohmic Value should be below  $25\text{m}\Omega$  for minimizing power consumption at the current sensing resistor.
- Tight Tolerance must be  $\pm 1\%$  or tighter for maximizing the current supply within the limit of acceptable current.
- Low TCR is required for current sensing across the ambient temperature range of  $0^\circ\text{C}$  to  $60^\circ\text{C}$ .
- Low Thermal EMF for an accurate comparison between the programmed current-limiting voltage of the control IC and the detected voltage.

Furthermore, the self-inductance should be for high frequency applications. Recommended types are general purpose current sensing products or a flame retardant type.

## How Four Terminal Sense Resistor Work

High precision resistors used for current sensing are usually low ohmic value devices suitable for four terminal connection. To use a 4-terminal resistor, we force a current from Terminal 1 to Terminal 2. It's current, so the unknown resistances attached to Terminal 1 and Terminal 2 don't affect the amount of the current. The same number of electrons per second flow through from T1 to T2, regardless of the resistance.

A voltmeter measures the resulting voltage drop across the ultra-precise resistor, measuring through the unknown resistors attached to Terminal 3 and Terminal 4. The voltmeter's input impedance is very, very high compared to the unknown resistors, so the unknown resistors have essentially zero effect (typically less than 0.1 parts-per-million).

So the current flows through the  $0.100\ \text{ohm}$  resistor, unaffected by the unknown resistors, and we measure the voltage across the  $0.100\ \text{ohm}$  resistor, unaffected by the unknown resistors. And that's how a 4-terminal resistor works!

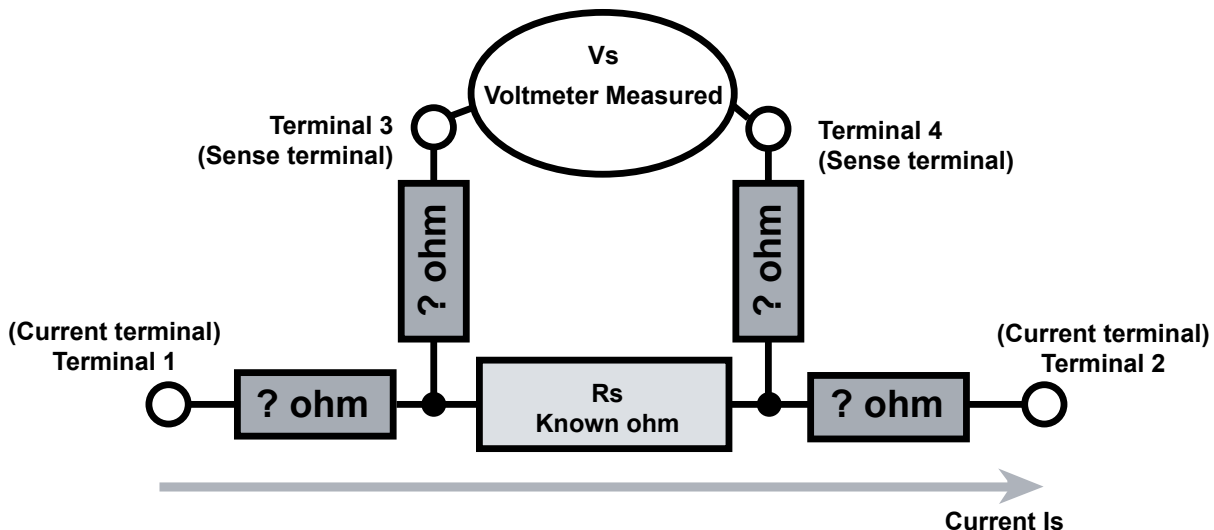

## **Flip Chip Resistor**

An unencapsulated resistor chip on which bead-type leads terminate on one face to permit “flip” (face down) mounting of the resistor chip by contact of the leads with interconnective circuitry.

## **Hot-Spot Temperature**

The maximum temperature measured on the resistor due to both internal heating and the ambient operating temperature.

## **Low Profile**

Components designed with “lower than standard heights”, to save space and allow clearance when mounted on PCBs.

## **Maximum Working Voltage**

The maximum specified voltage that may be applied across a resistor.

## **PPM**

Parts per million. The terminology used when describing the temperature coefficient.

## **Screen**

The process of printing a network pattern of thick-film ink or paste onto a substrate by means of a squeegee applied to a photo-etched wire-mesh “silk screen” or metal mask.

## **Current Shunt Resistors**

Current shunt resistors are low resistance precision resistors used to measure AC or DC electrical currents by the voltage drop those currents create across the resistance. Sometimes called an ammeter shunt, it is a type of current sensor.

## **SMT/SMD**

Surface-mount technology/surface-mount device.

## **Zero Ohm Resistors**

Products that look like resistors, but actually have no resistance (very very low resistance) and instead perform as jumpers.

## Metal Strip Current Sense Chip Resistors

**Ultra Low Ohm Resistor Save Space, Time,  
and Money (LRC)**

### ▶ Preview

Providing design engineers with an economical low ohmic value, current sense metal strip chip resistor with high quality performance, Token Electronics LRC Series is suitable for applications in the automotive sector for applications that require high power handling (Up to 3W) and low resistance 0.5mΩ.

From a certified supplier offering the automotive quality, Token's LRC Series gives all round superior performance for current sensing in lamp detection, mirrors, window lift, steering and seat controls.

As a first instance, the LRC Series displays enhanced power handling capabilities, against other technologies.

Thermal conductivity is important for chip resistors - little heat is dissipated directly into the air, and instead, is conducted out through the solder pads.

The heat generated from the specially constructed LRC resistor is more readily dispersed, therefore preventing localised heating, which contributes to TCR and thermal EMF errors, premature aging and possible scorching of the PC board.

They are rated for ambient operation from -55°C to +170°C.

The LRC Series is RoHS compliant and lead free. Contact us with your specific needs.



### ▶ Features

- Low TCR ±50, ±100PPM/°C
- High Wattage Rating Up to 3W
- Customized Resistance Available
- Resistance Values from 0.5m ohms to 20m ohms
- Without Laser Trimmed with Very Low Inductance

### ▶ Applications

- For NB power management.
- For MB power management.
- For Monitor power management.
- SWPS: DC-DC converter, Charger, Adaptor.

## ► Low Ohmic (LRC) Construction

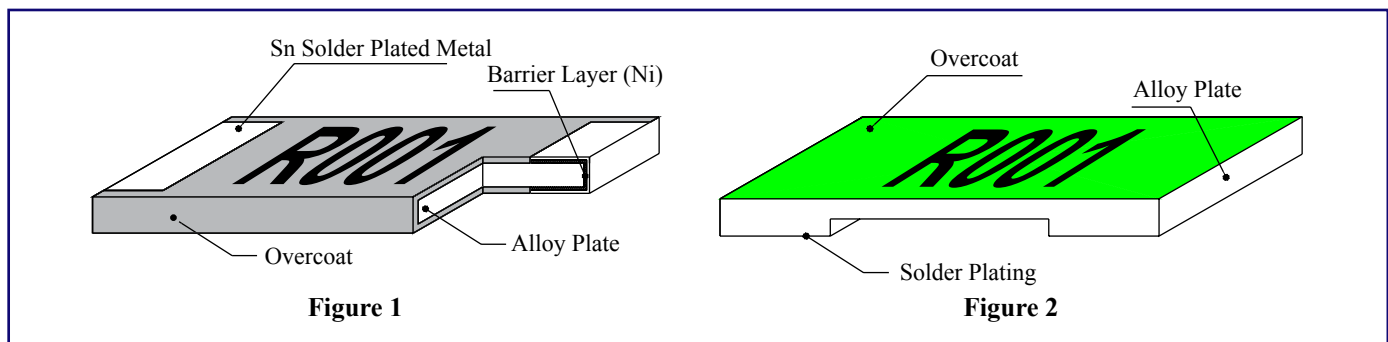

## ► SMD 2512, 2010, 1206 (LRC) Dimensions

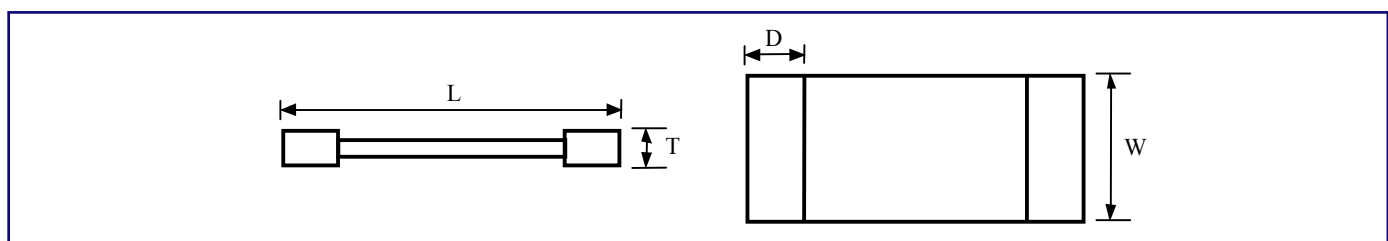

Type	Resistance (mΩ)	L(mm)	W(mm)	T(mm)	D(mm)
LRC12*T*0M50G	0.50	6.35±0.25	3.00±0.20	0.60±0.20	2.68±0.25
LRC12*T*0M75G	0.75	6.35±0.25	3.00±0.20	0.60±0.20	2.48±0.25
LRC12*T*R001G	1.0	6.35±0.25	3.00±0.20	0.60±0.20	1.93±0.25
LRC12*T*1M50G	1.5	6.35±0.25	3.00±0.20	0.60±0.20	1.43±0.25
LRC12*T***G	2.0~3.0	6.35±0.25	3.00±0.20	0.60±0.20	1.18±0.25
LRC12*T*R004G	4.00	6.35±0.25	3.00±0.20	0.60±0.20	2.18±0.25
LRC12*T***G	5.0~6.0	6.35±0.25	3.00±0.20	0.60±0.20	1.93±0.25
LRC12*T*R007G	7.00	6.35±0.25	3.00±0.20	0.60±0.20	1.43±0.25
LRC12*T***G	8.0~15	6.35±0.25	3.00±0.20	0.60±0.20	1.18±0.25
LRC12*T*0M50	0.50	6.35±0.25	3.18±0.25	1.40±0.20	1.43±0.38
LRC12*T*0M75	0.75	6.35±0.25	3.18±0.25	1.00±0.20	1.43±0.38
LRC12*T*R001	1.00	6.35±0.25	3.18±0.25	0.80±0.20	1.43±0.38
LRC12*T*1M50	1.50	6.35±0.25	3.18±0.25	0.65±0.20	1.43±0.38
LRC12*T*R002	2.00	6.35±0.25	3.18±0.25	0.50±0.20	1.43±0.38
LRC12*T*2M50	2.50	6.35±0.25	3.18±0.25	1.00±0.20	1.43±0.38
LRC12*T*R003	3.00	6.35±0.25	3.18±0.25	0.70±0.20	1.43±0.38
LRC12*T*R004	4.00	6.35±0.25	3.18±0.25	0.60±0.20	1.43±0.38
LRC12*T*R005	5.00	6.35±0.25	3.18±0.25	0.50±0.20	1.43±0.38
LRC12*T*R006	6.00	6.35±0.25	3.18±0.25	0.50±0.20	1.43±0.38
LRC12*T*6M50	6.50	6.35±0.25	3.18±0.25	0.45±0.20	1.43±0.38
LRC12*T*R007	7.00	6.35±0.25	3.18±0.25	0.45±0.20	1.43±0.38
LRC10*T***	1.0~10	5.08±0.25	2.54±0.15	0.60±0.20	1.67±0.63
LRC06*T***	1.0~10	3.20±0.25	1.60±0.10	0.60±0.20	0.98±0.38

Notice : TOKEN is capable of manufacturing the optional spec based on customer's requirement.

## ▶ SMD 2512, 1206 (LRC) Standard Electrical Specifications

Type	Power Rating at 80°C	Operating Temp. Range	Resistance Tolerance (±%)	Resistance (mΩ)	TCR (±PPM/°C)
LRC12*TK**	1W	-55°C ~ +170°C	1, 3, 5	2.5~3.5	150
LRC12*TE**	1W			4.0~5.5	100
LRC12*TW**	1W			6.0~7.0	75
LRC12*TD**G	1W			11.0~15.0	50
LRC12*TD**	1W			0.5~2.0	50
LRC06*TD**	1W			1.0~10.0	50

Remark : Operating Current  $I = \sqrt{P / R}$  , Operating Voltage  $V = \sqrt{P * R}$

## ▶ SMD 2512, 2010 (LRC) High Power Rating Electrical Specifications

Type	Power Rating at 80°C	Operating Temp. Range	Resistance Tolerance (±%)	Resistance (mΩ)	TCR (±PPM/°C)
LRC12*TDS*	2.0W	-55°C ~ +170°C	1, 3, 5	0.5~2.0	50
LRC12*TDS*G	2.0W			3.5	50
LRC12*TDS*G	2.0W			6.5~10.0	50
LRC12*TDB*G	2.5W			4.0~6.0	50
LRC12*TDR*G	3.0W			1.0~3.0	50
LRC12*TER*G	3.0W			0.5~0.75	100
LRC10*TDA*	1.5W			1.0~10.0	50

Remark : Operating Current  $I = \sqrt{P / R}$  , Operating Voltage  $V = \sqrt{P * R}$

## ▶ Surface Mount Chips (LRC) Packing Quantity

Type	Emboss Plastic Tape
LRC12 (2512)	2,000
LRC10 (2010)	2,000
LRC06 (1206)	2,000

## ▶ (LRC) Derating Curve

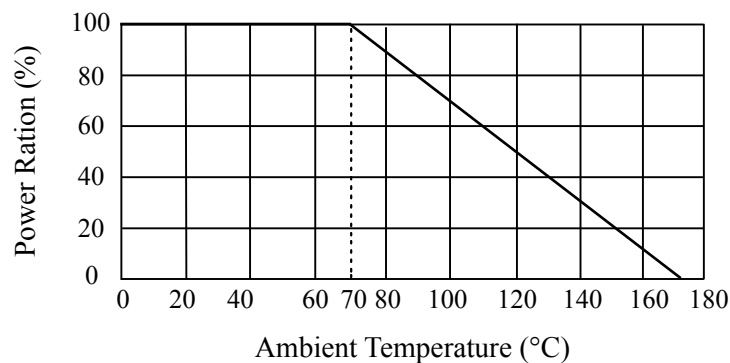

## ▶ Surface Mount (LRC) Emboss Plastic Tape Specifications

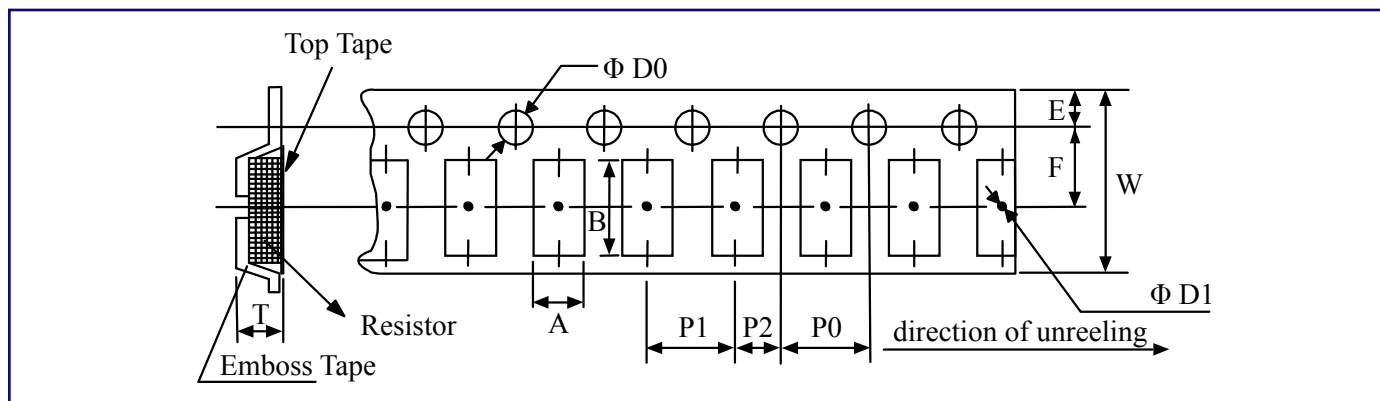

Size	Resistance (mΩ)	A	B	W	E	F	P0	P1	P2	ΦD0	ΦD0	T
LRC12	0.50~7	3.40±0.1	6.73±0.1	12.0±0.1	1.75±0.1	5.5±0.05	4.0±0.1	4.00±0.1	2.0±0.05	1.50±0.10	1.4min	0.81±0.1
	0.50~15	3.40±0.1	6.75±0.1	12.0±0.1	1.75±0.1	5.5±0.05	4.0±0.1	4.00±0.1	2.0±0.05	1.55±0.05	1.4min	0.80±0.1
LRC10	1~10	2.85±0.1	5.55±0.1	12.0±0.2	1.75±0.1	5.5±0.05	4.0±0.1	4.00±0.1	2.0±0.05	1.55±0.05	1.4min	0.85±0.1
LRC06	1~10	1.90±0.1	3.60±0.1	8.0±0.2	1.75±0.1	3.5±0.05	4.0±0.1	4.00±0.1	2.0±0.05	1.55±0.05	1.0min	0.87±0.1

- Notice:**
1. The cumulative tolerance of 10 sprocket hole pitch is  $\pm 0.2\text{mm}$ .
  2. Carrier camber shall be not more than 1mm per 100mm through a length of 250mm.
  3. A & B measured 0.3mm from the bottom of the packet.
  4. t measured at a point on the inside bottom of the packet to the top surface of the carrier.
  5. Pocket position relative to sprocket hole is measured as the true position of the pocket and not the pocket hole.

## ▶ Low Ohmic (LRC) Environmental Characteristics

Item	Specification		Test Method
	Black coating	Green coating	
Temperature Coefficient of Resistance	As Spec.		MIL-STD-202 Method 304 +25/-30/+25/+130/+25°C
Thermal Shock	$\pm 0.5\% + 0.5\text{m}\Omega$	$\pm 1\%$	MIL-STD-202 Method 107G -55°C~150°C, 100 cycles
Short Time Overload	$\pm 0.5\% + 0.5\text{m}\Omega$	$\pm 1\%$	JIS-C-5202-5.5 RCWV*2.5 or Max Overloading Voltage, 5 seconds
Resistance to Dry Heat	$\pm 1\% + 0.5\text{m}\Omega$	$\pm 1\%$	JIS-C-5202-7.2 96 hours @ +125°C without load
Load Life	$\pm 1\% + 0.5\text{m}\Omega$	$\pm 1\%$	MIL-STD-202 M108 RCWV, 70°C, 1.5 hours on, 0.5 hours off 1000~1048 hours
Resistance to Soldering Heat	$\pm 0.5\% + 0.5\text{m}\Omega$	$\pm 1\%$	MIL-STD-202F Method 210E 260±5°C, 10±1second
Solderability	95%min coverage		MIL-STD-202F Method 210E 260±5°C, 2±0.5second

**Remark:** Green coating can't be work with wave soldering bath. Humidity < 80%RH; Storage Temperature: 25±3°C

## How to Order

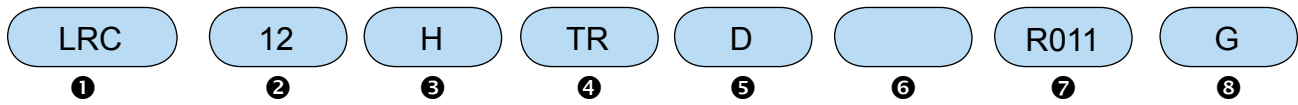

### 1 Part Number

### 2 Dimensions (L×W)

Code	Dimensions (L×W)
12	EIA2512 6.3×3.1mm
10	EIA2010 5.1×2.5mm
06	EIA1206 3.2×1.6mm

### 3 Resistance Tolerance

Code	Resistance Tolerance
J	±5%
H	±3%
F	±1%

### 4 Package

Code	Packaging
TR	Taping Reel

### 5 TCR

Code	TCR
D	±50PPM/°C
W	±75PPM/°C
E	±100PPM/°C
K	±150PPM/°C

### 6 Power Rating

Code	Power Rating
	Standard (1W)
A	(1.5W)
S	(2W)
R	(3W)
B	(2.5W)

### 7 Resistance

Code	Resistance
0M50	0.00050Ω
0M75	0.00075Ω
1M50	0.00150Ω
R002	0.00200Ω
R010	0.01000Ω

### 8 Protective Coating

Code	Packaging
	Black Coating
G	Green Coating
**2010/1206	No coating / marking

*Back to 1st Page - Current Sense Metal Strip Chip Resistors (LRC)*

# Surface Mount Current Detecting Chip Resistors

## CS Surface Mount Current Detecting Resistors Save Space and Weight

### ▶ Preview

Token Electronics has launched the CS series, a family of ultra small low-value current-sense surface-mount chip resistors. These smaller sizes save space on the circuit board, allowing the production of smaller and lighter products.

The new series complements Token's existing LRC Series, offering metal resistive film on ceramic construction but providing increased choice for product designers in the form of more smaller sizes options of 0201, 0402, 0603, 0805, 1206, 2010, 2512, 1225, 3720, and 7520.

Designed for current detecting in power electronic systems, the fully RoHS compliant CS series is suitable for a range of applications including the monitoring of power usage and battery life; and provision of output protection for power supplies; as well as for a range of consumer and automotive products such as satellite navigation, handheld PDAs and digital set-top boxes.

The series offers ohmic values as low as  $1\text{m}\Omega$  to minimise power consumption and has an ambient temperature range of  $-55^\circ\text{C}$  to  $+155^\circ\text{C}$ .

Exhibiting a resistance range up to  $1\Omega$  and excellent heat dissipation qualities, the series offers designers enhanced power handling capabilities and protection from the threat of localised heating, resulting in the production of a more energy efficient product.

As demand continues to grow for reduced size, handheld and portable devices operating at low voltages, designers will look to manufacturers to produce smaller and smaller current sense resistors. Token expects that demand for its latest range of small size resistors will be high.

Contact us with your specific needs.

### ▶ Features

- Low TCR  $\pm 50, \pm 100\text{PPM}/^\circ\text{C}$
- Resistance Values from  $1\text{m}\Omega$  to  $1\Omega$ .
- 3W Power Rating in 1W size, 1225 Package.
- Long size Terminations with Higher Power Rating.
- High Purity Alumina Substrate for High Power Dissipation.
- Products with Pb-free Terminations Meet RoHS Requirements.

### ▶ Applications

- Voltage Regulation Module (VRM).
- Portable Devices (PDA, Cell phone).
- Disk Driver, Switching Power Supply.
- Over Current Protection in Audio Application.
- DC-DC Converter, Battery Pack, Charger, Adaptor.
- Automotive Engine Control, Power Management Applications.



## ▶ Dimensions (Unit: mm)

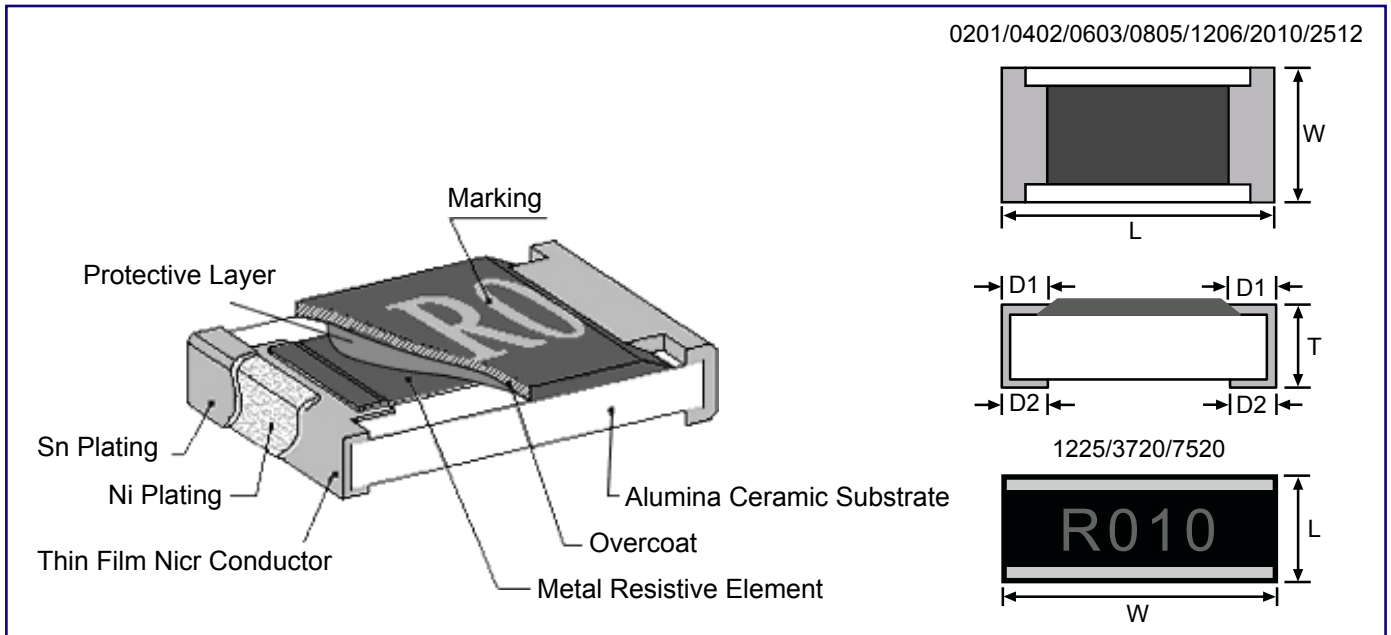

Type	L (Unit: mm)	W (Unit: mm)	T (Unit: mm)	D1 (Unit: mm)	D2 (Unit: mm)
CS01 (0201)	0.58±0.05	0.29±0.05	0.23±0.05	0.12±0.05	0.15±0.05
CS02 (0402)	1.00±0.05	0.50±0.05	0.32±0.10	0.25±0.10	0.20±0.10
CS03 (0603)	1.60±0.10	0.80±0.10	0.45±0.10	0.30±0.20	0.30±0.20
CS05 (0805)	2.00±0.15	1.25±0.15	0.55±0.10	0.30±0.20	0.40±0.25
CS06 (1206)	3.05±0.15	1.55±0.15	0.55±0.10	0.50±0.30	0.40±0.25
CS13 (1210)	3.00±0.15	2.50±0.15	0.55±0.10	0.50±0.30	0.50±0.25
CS10 (2010)	5.00±0.20	2.45±0.15	0.60±0.15	0.60±0.30	0.50±0.25
CS12 (2512)	6.35±0.20	3.15±0.15	0.60±0.10	0.60±0.30	0.55±0.25
CS12 (2512)(2W)(10~99mΩ)	6.35±0.20	3.15±0.15	0.74±0.10	0.60±0.30	0.55±0.25
CS12 (2512)(2W)(100~1000mΩ)	6.35±0.20	3.15±0.15	0.74±0.10	0.60±0.30	2.70±0.10
CS25 (1225)	3.10±0.15	6.30±0.15	0.90±0.15	0.60±0.30	0.55±0.25
CS37 (3720)	2.00±0.20	3.75±0.20	0.60±0.10	0.40±0.20	0.40±0.20
CS75 (7520)	2.00±0.20	7.50±0.30	0.60±0.10	0.40±0.20	0.40±0.20

## Standard Electrical Specifications

Type	Power Rating at 70°C	Operating Temp. Range	Resistance Tolerance	Resistance Range	TCR (PPM/°C)	
CS01 (0201)	1/20W	-55 ~ +155°C	±1% ±2% ±5%	100mΩ~149mΩ 150mΩ~500mΩ 501mΩ~1000mΩ	±1000PPM/°C ±600PPM/°C ±300PPM/°C	
CS02 (0402)	1/16W			50mΩ~100mΩ 101mΩ~500mΩ 501mΩ~1Ω	±400PPM/°C ±300PPM/°C ±200PPM/°C	
CS03 (0603)	1/10W			20mΩ~50mΩ 51mΩ~100mΩ 101mΩ~500mΩ 501mΩ~1Ω	±600PPM/°C ±400PPM/°C ±300PPM/°C ±200PPM/°C	
CS05 (0805)	1/8W			20mΩ~50mΩ 51mΩ~100mΩ 101mΩ~500mΩ 501mΩ~1Ω	±600PPM/°C ±400PPM/°C ±300PPM/°C ±200PPM/°C	
CS06 (1206)	1/4W			10mΩ~20mΩ 21mΩ~50mΩ	±600PPM/°C ±400PPM/°C	
CS13 (1210)	1/2W			51mΩ~500mΩ 501mΩ~1Ω	±300PPM/°C ±200PPM/°C	
CS10 (2010)	3/4W			3mΩ~5mΩ 6mΩ~20mΩ 21mΩ~30mΩ 31mΩ~200mΩ	±300PPM/°C ±200PPM/°C ±150PPM/°C ±100PPM/°C ±200PPM/°C	
CS12 (2512)	1W					
CS25 (1225)	3W					
CS37 (3720)	1W			10mΩ~19mΩ 20mΩ~500mΩ	±300PPM/°C ±150PPM/°C	
CS75 (7520)	2W			±2%,±5%	1mΩ~4mΩ	±300PPM/°C
				±1%,±2%,±5%	5mΩ~10mΩ 11mΩ~350mΩ	±200PPM/°C ±150PPM/°C

Note:Token has the ability to manufacture following options based on customer's requirement.

## Low TCR Electrical Specifications

Type	Power Rating at 70°C	Operating Temp. Range	Resistance Tolerance	Resistance Range	TCR
CS06*TRE**	1/4W	-55 ~ +155°C	±1% ±2% ±5%	100mΩ~1000mΩ	±100PPM/°C
CS13*TRE**	1/2W			100mΩ~1000mΩ	±100PPM/°C
CS10*TRE**	3/4W			100mΩ~1000mΩ	±100PPM/°C
CS12*TRE**	1W			20mΩ~1000mΩ	±100PPM/°C
CS37*TRE**	1W			100mΩ~500mΩ	±100PPM/°C
CS75*TRE**	2W			50mΩ~350mΩ	±100PPM/°C

## ▶ High Power Rating Electrical Specifications

Type	Power Rating at 70°C	Operating Temp. Range	Resistance Tolerance	Resistance Range	TCR
CS03*TR*W**	1/8W	-55 ~ +155°C	±1% ±2% ±5%	51mΩ~100mΩ	±400PPM/°C
CS05*TR*V**	1/4W 1/2W			101mΩ~500mΩ	±300PPM/°C
CS06*TR*U**	1/2W			501mΩ~1000mΩ	±200PPM/°C
CS13*TR*Q**	3/4W			10mΩ~20mΩ	±600PPM/°C
CS10*TR*T**	1W			21mΩ~50mΩ	±400PPM/°C
CS12*TR*A**	1.5W			51mΩ~500mΩ	±300PPM/°C
CS12*TR*S**	2W			501mΩ~1000mΩ	±200PPM/°C

## ▶ Power Derating Curve

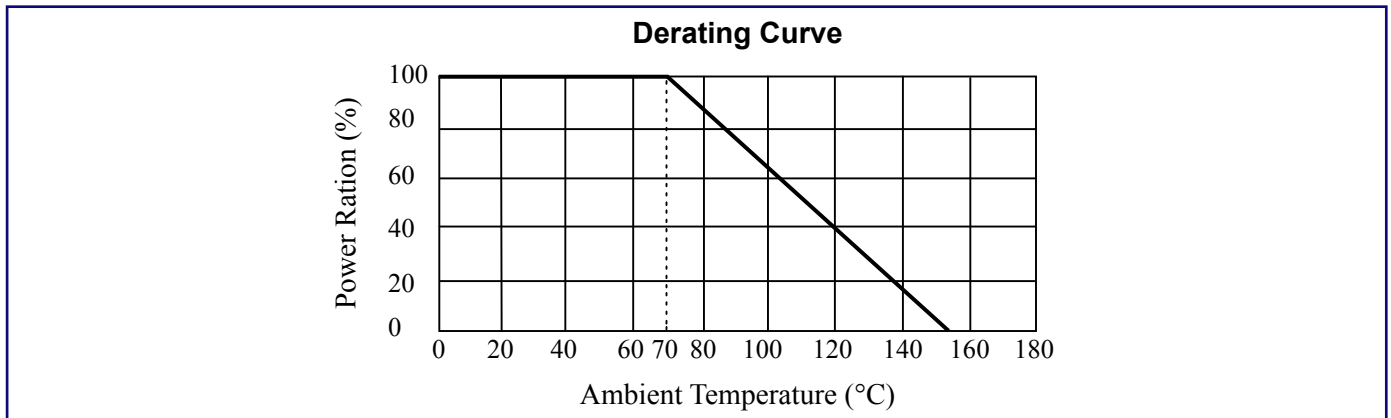

## ► Environmental Characteristics

Item	Specification	Test Method
Temperature Coefficient of Resistance	As Spec	MIL-STD-202F Method 304 +25/-55/+25/+125/+25°C
Short Time Overload	$\pm(0.5\% + 0.05\Omega)$	JIS-C-5202-5.5
	$\Delta R \pm 1\%$ for high power rating	RCWV*2.5 or Max Overloading Voltage 5seconds
Dielectric Withstand Voltage	by Type	MIL-STD-202F Method 301 Apply Max Overload Voltage for 1 minute
Insulation Resistance	$>1000M\Omega$	MIL-STD-202F Method 302 Apply 100VDC for 1 minute
Thermal Shock	$\pm(0.5\% + 0.05\Omega)$	MIL-STD-202F Method 107G -55°C~150°C, 100cycles
Load Life	$\pm(1\% + 0.05\Omega)$	MIL-STD-202F Method 108A RCWV, 70°C, 1.5 hours on , 0.5 hours off , 1000~1048 hours
humidity (Steady State)	$\pm(0.5\% + 0.05\Omega)$	MIL-STD-202F Method 103B 40°C, 90~95%RH, RCWV 1.5 hours ON, 0.5 hours OFF, total 1000 ~ 1048 hours
Resistance to dry heat	$\pm(0.5\% + 0.05\Omega)$	JIS-C-5202-7.2 96hours @ +155°C without load
Low Temperature Operation	$\pm(0.5\% + 0.05\Omega)$	JIS-C-5202-7.1 1hour, -65°C followed by 45minutes of RCWV
Bending Strength	As Spec	JIS-C-5202-6.1.4 Bending Amplitude 3mm for 10seconds
Solderability	95%min coverage	MIL-STD-202F Method 208H 260°C±5°C, 2±0.5 (sec)
Resistance to Soldering Heat	$\pm(0.5\% + 0.05\Omega)$	MIL-STD-202F Method 210E 260±5°C, 10±1 second

Note: Storage Temperature: 25±3°C; Humidity: <80%RH

## ► (CS) Marking for 0603

Marking	Value
1R0	1.000Ω
R10	0.100Ω
R01	0.010Ω
<u>101</u>	0.101Ω
<u>035</u>	0.035Ω

▶ Except For CS12: High Power Rating Series Recommend Land Pattern

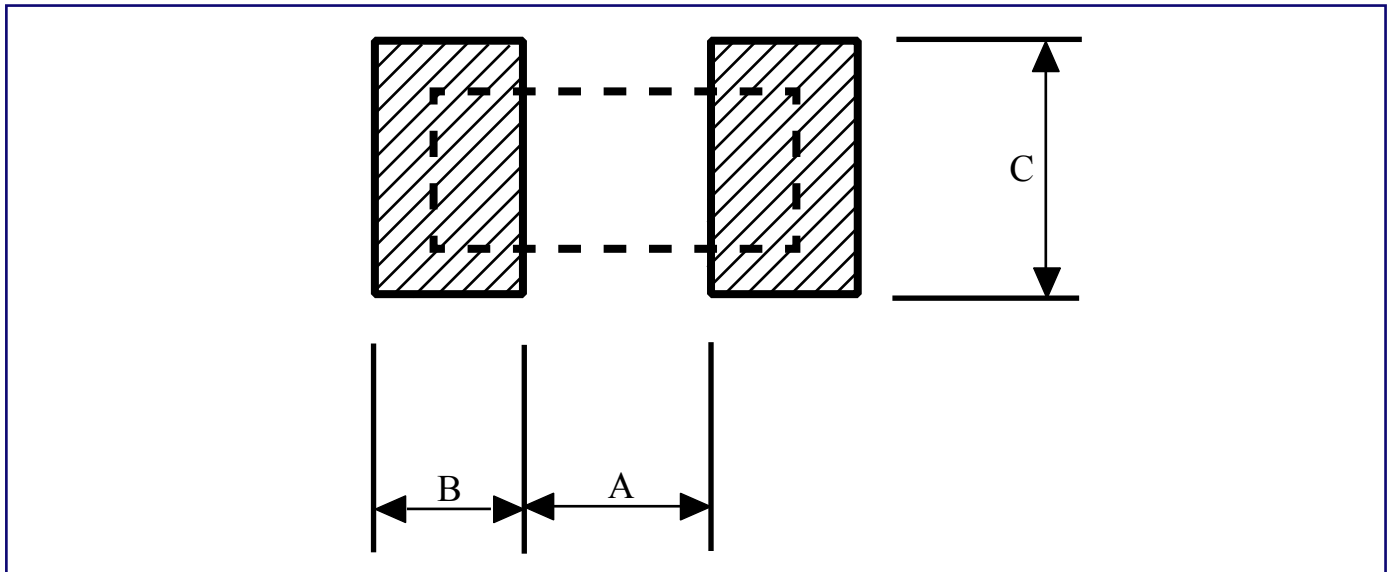

Codes	A	B	C
CS01	0.25	0.30	0.40±0.2
CS02	0.50	0.50	0.60±0.2
CS03	0.80	1.00	0.90±0.2
CS05	1.00	1.00	1.35±0.2
CS06	2.00	1.15	1.70±0.2
CS13	2.00	1.15	2.50±0.2
CS10	3.60	1.40	2.50±0.2
CS12	4.90	1.60	3.10±0.2
CS25	2.00	2.00	6.40±0.2
CS37	1.00	1.80	3.90±0.2
CS75	1.00	1.80	7.60±0.2

▶ For CS12 High Power Rating Series Recommend Land Pattern

Codes	Resistance Range	A	B	C
CS12	10~99mΩ	4.90	1.60	3.10±0.2
CS12	100~1000mΩ	1.00	3.55	3.10±0.2

## Packing Quantity & Reel Specifications

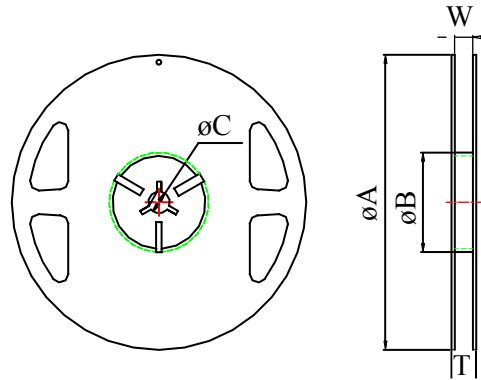

Type	ΦA	ΦB	ΦC	W	T	Paper Tape(EA)	Emboss Plastic Tape(EA)
CS01	178.0±1.0	60.0±1.0	13.5±0.7	9.5±1.0	11.5±1.0	10,000	-
CS02	178.0±1.0	60.0±1.0	13.5±0.7	9.5±1.0	11.5±1.0	10,000	-
CS03	178.0±1.0	60.0±1.0	13.5±0.7	9.5±1.0	11.5±1.0	5,000	-
CS05	178.0±1.0	60.0±1.0	13.5±0.7	9.5±1.0	11.5±1.0	5,000	-
CS06	178.0±1.0	60.0±1.0	13.5±0.7	9.5±1.0	11.5±1.0	5,000	-
CS13	178.0±1.0	60.0±1.0	13.5±0.7	9.5±1.0	11.5±1.0	5,000	-
CS10	178.0±1.0	60.0±1.0	13.5±0.7	13.5±1.0	15.5±1.0	-	4,000
CS12	178.0±1.0	60.0±1.0	13.5±0.7	13.5±1.0	15.5±1.0	-	4,000
CS12(2W)	178.0±1.0	60.0±1.0	13.5±0.7	13.5±1.0	15.5±1.0	-	2,000
CS25	178.0±1.0	60.0±1.0	13.5±0.7	13.5±1.0	15.5±1.0	-	2,000
CS37	178.0±1.0	60.0±1.0	13.5±0.7	13.5±1.0	15.5±1.0	-	2,000
CS75	178.0±1.0	60.0±1.0	13.5±0.7	17.5±1.0	19.5±1.0	-	2,000

## Paper Tape Specifications

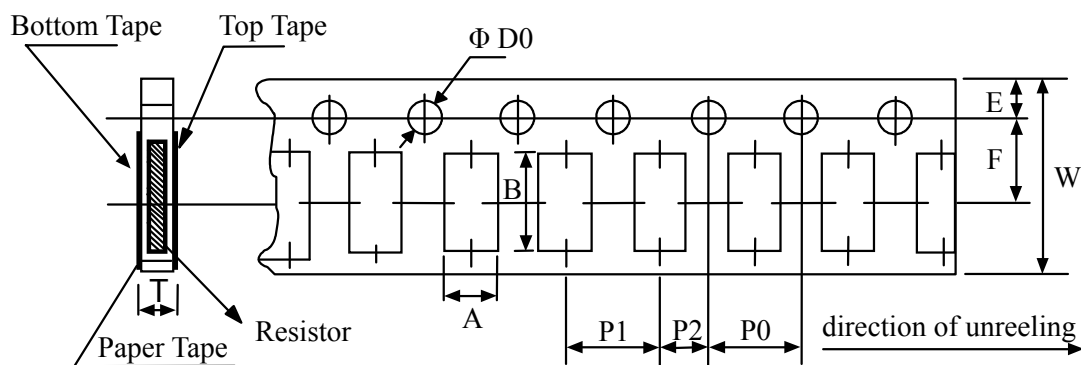

Type	A	B	W	E	F	P0	P1	P2	ΦD0	T
CS01	0.40±0.05	0.70±0.05	8.00±0.10	1.75±0.05	3.5±0.05	4.00±0.10	2.00±0.05	2.00±0.05	1.55±0.05	0.42±0.02
CS02	0.70±0.05	1.16±0.05	8.00±0.10	1.75±0.05	3.50±0.05	4.00±0.10	2.00±0.05	2.00±0.05	1.55±0.05	0.40±0.03
CS03	1.10±0.05	1.90±0.05	8.00±0.10	1.75±0.05	3.50±0.05	4.00±0.10	4.00±0.10	2.00±0.05	1.55±0.05	0.60±0.03
CS05	1.60±0.05	2.37±0.05	8.00±0.10	1.75±0.05	3.50±0.05	4.00±0.10	4.00±0.10	2.00±0.05	1.55±0.05	0.75±0.05
CS06	2.00±0.05	3.55±0.05	8.00±0.10	1.75±0.05	3.50±0.05	4.00±0.10	4.00±0.10	2.00±0.05	1.55±0.05	0.75±0.05
CS13	2.75±0.05	3.40±0.05	8.00±0.10	1.75±0.05	3.5±0.05	4.00±0.10	4.00±0.05	2.00±0.05	1.55±0.05	0.75±0.05

## How to Order

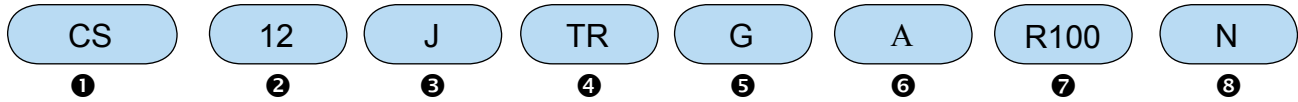

### 1 Part Number

### 2 Dimensions (L×W)

Code	Dimensions (L×W)	
01	0.58×0.29	0201
02	1.00×0.50mm	0402
03	1.60×0.80mm	0603
05	2.00×1.25mm	0805
06	3.10×1.55mm	1206
13	3.00×2.50	1210
10	5.00×2.50mm	2010
12	6.30×3.10mm	2512
25	3.10×6.30mm	1225
37	3.75×2.00mm	3720
75	7.50×2.00mm	7520

### 3 Resistance Tolerance

Code	Resistance Tolerance
J	±5%
G	±2%
F	±1%

### 4 Packaging

Code	Packaging
TR	Taping Reel
P	Bulk

### 5 TCR

Code	TCR
E	±100ppm/°C
K	±150ppm/°C
F	±200ppm/°C
G	±300ppm/°C
H	±400ppm/°C
J	±600ppm/°C
R	±1000ppm/°C

### 6 Power Rating

Code	Power Rating
S	2W
A	1.5W
T	1W
Q	3/4W
U	1/2W
V	1/4W
W	1/8W

### 7 Resistance

Code	Resistance
R010	0.01Ω
R100	0.100Ω
1R00	1.000Ω

### 8 Marking

Code	Resistance
	Standard
N	No Marking

# Thin Film Current Sense Chip Resistors

## TCS Surface Mount Resistors Make Sense of Current

### ▶ Preview

The trend towards smaller handheld and portable electronics equipment has also increased the need for ultra small current sensing resistors. Devices from the Token Electronics' TCS series use a thin film construction that enables them to achieve precision resistance tolerances, low noise and long-term stability.

The Token TCS Series precision resistors are nichrome thin film chip resistors with a temperature coefficient of resistance of just  $\pm 50\text{PPM}/^\circ\text{C}$  and tolerances of  $\pm 0.5\%$ .

They offer excellent stability at high frequencies and are suitable for operating high voltages with more options in the smaller form sizes of 0402, 0603, 0402, 0805, 1206, 2010, and 2512.

The full range of values is from  $50\text{m}\Omega$  to  $1\Omega$ . This low ohmic devices are particularly suited to car engine management units to act as current sensing shunt resistors.

The TCS series is fully RoHS compliant and is supplied in tape and reel packaging ready for use with automated assembly processes.

Contact us with your specific needs.

### ▶ Features

- Thin Film Process.
- Resistance Values from  $50\text{m}\Omega$  to  $1\Omega$ .
- Very Tight Tolerance from  $\pm 1\%$  to  $\pm 0.5\%$ .
- RoHS Requirements with Pb-free Terminations.
- Extremely Low TCR from  $\pm 200\text{PPM}/^\circ\text{C}$  to  $\pm 50\text{PPM}/^\circ\text{C}$ .
- High Purity Alumina Substrate for High Power Dissipation.



### ▶ Applications

- Voltage Regulation Module (VRM),
- Portable Devices (PDA, Cell phone),
- Disk Driver, Switching Power Supply,
- Over Current Protection in Audio Application,
- DC-DC Converter, Battery Pack, Charger, Adaptor,
- Automotive Engine Control, Power Management Applications

## ► Dimensions (Unit: mm)

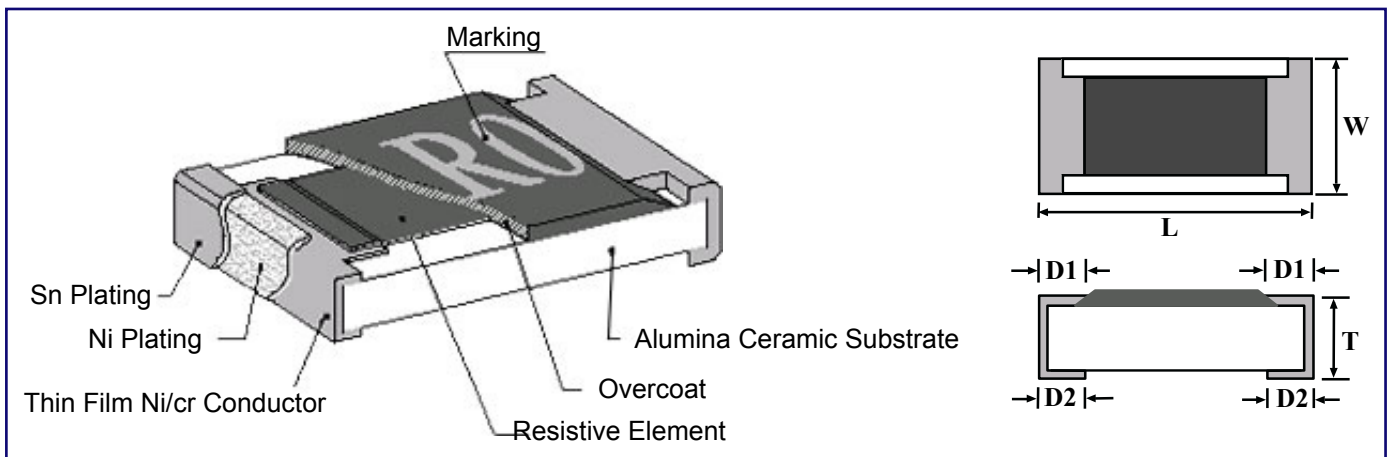

Type	L	W	T	D1	D2
TCS02	1.00±0.05	0.50±0.05	0.32±0.10	0.25±0.10	0.20±0.10
TCS03	1.60±0.10	0.80±0.10	0.45±0.10	0.30±0.20	0.30±0.20
TCS05	2.00±0.15	1.25±0.15	0.55±0.10	0.30±0.20	0.40±0.25
TCS06	3.05±0.15	1.55±0.15	0.55±0.10	0.50±0.30	0.40±0.25
TCS10	5.00±0.20	2.45±0.15	0.60±0.15	0.60±0.30	0.50±0.25
TCS12	6.35±0.20	3.15±0.15	0.60±0.10	0.60±0.30	0.55±0.25

## ► Standard Electrical Specifications

Type	Power Rating at 70°C	Operating Temp. Range	Resistance Tolerance	Resistance Range	TCR (PPM/°C)
TCS02 (0402)	1/16W	-55 ~ +155°C	±0.5% ±1.0%	500mΩ~999mΩ	±100 ±50
TCS03 (0603)	1/10W		±0.5% ±1.0%	200mΩ~300mΩ 301mΩ~999mΩ	±100 ±50
TCS05 (0805)	1/8W		±1.0%	50mΩ~100mΩ	±200 ±100
TCS06 (1206)	1/4W		±0.5% ±1.0%	101mΩ~300mΩ 301mΩ~999mΩ	±50
TCS10 (2010)	3/4W		±0.5% ±1.0%	50mΩ~100mΩ 101mΩ~300mΩ 301mΩ~999mΩ	±200 ±100 ±50
TCS12 (2512)	1W		±0.5% ±1.0%	50mΩ~100mΩ 101mΩ~300mΩ 301mΩ~999mΩ	±200 ±100 ±50

Note: Token has the ability to manufacture following options based on customer's requirement.

## ► High Power Rating Electrical Specifications

Type	Power Rating at 70°C	Operating Temp. Range	Resistance Tolerance	Resistance Range	TCR (PPM/°C)
TCS12 (2512)	3W	-55 ~ +155°C	±1.0%	100mΩ~1Ω	±100

## ▶ Power Derating Curve

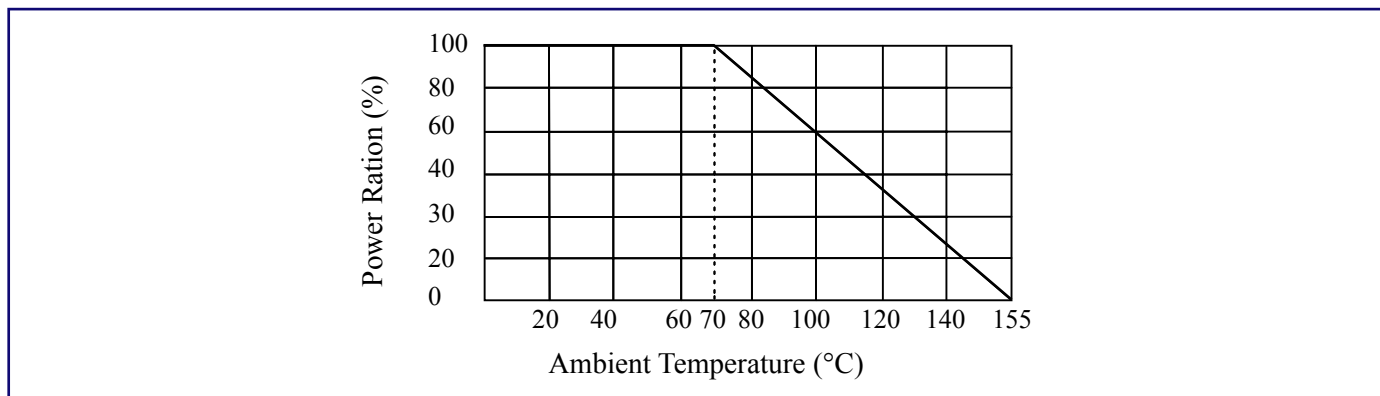

## ▶ Environmental Characteristics

Item	Specification	Test Method
Temperature Coefficient of Resistance	As Spec	MIL-STD-202F Method 304 +25/-55/+25/+125/+25°C
Short Time Overload	±0.5%	JIS-C-5202-5.5 RCWV*2.5 or Max Overloading Voltage 5seconds
Dielectric Withstand Voltage	by Type	MIL-STD-202F Method 301 Apply Max Overload Voltage for 1 minute
Insulation Resistance	>1000MΩ	MIL-STD-202F Method 302 Apply 100VDC for 1minute
Thermal Shock	±0.5%	MIL-STD-202F Method 107G -55°C~150°C, 100cycles
Load Life	±1%	MIL-STD-202F Method 108A RCWV, 70°C, 1.5 hours on , 0.5 hours off , Total 1000~1048 hours
Humidity (Steady State)	±0.5%	MIL-STD-202F Method 103B 40°C, 90~95%RH, RCWV 1.5 hours ON, 0.5 hours OFF, total 1000 ~ 1048 hours
Resistance to dry heat	±0.5%	JIS-C-5202-7.2 96hours @ +155°C without load
Low Temperature Operation	±0.5%	JIS-C-5202-7.1 1hour, -65°C followed by 45minutes of RCWV
Bending Strength	As Spec	JIS-C-5202-6.1.4 Bending Amplitude 3mm for 10seconds
Solderability	95%min coverage	MIL-STD-202F Method 208H 245°C±5°C, 2±0.5 (sec)
Resistance to Soldering Heat	±0.5%	MIL-STD-202F Method 210E 260±5°C, 10±1 second

Note: Storage Temperature: 25±3°C; Humidity: <80%RH

## ▶ Marking for 0603

Marking	Value
1R0	1.000Ω
R10	0.100Ω
R01	0.010Ω
<u>101</u>	0.101Ω
<u>035</u>	0.035Ω

## ▶ Packaging Quantity & Reel Specifications

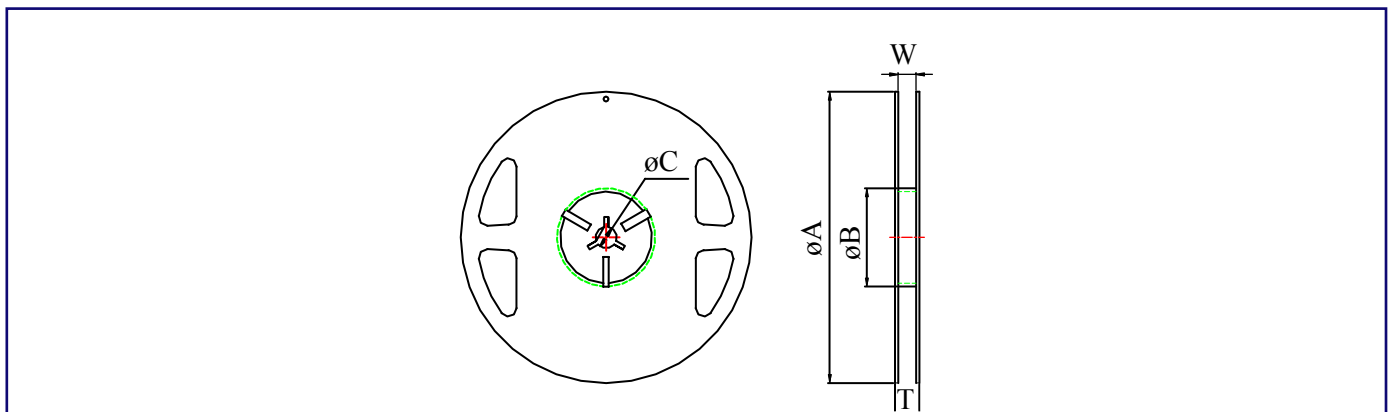

Type	ΦA	ΦB	ΦC	W	T	Paper Tape	Emboss Plastic Tape
TCS02	178±1	60.0+0.5	13.0±0.20	9.00±0.50	12.0±0.15	10,000	-
TCS03	178±1	60.0+0.5	13.0±0.20	9.00±0.50	12.0±0.15	5,000	-
TCS05	178±1	60.0+0.5	13.0±0.20	9.00±0.50	12.0±0.15	5,000	-
TCS06	178±1	60.0+0.5	13.0±0.20	9.00±0.50	12.0±0.15	5,000	-
TCS10	178±1	60.2±0.5	13.0±0.50	13.2±1.50	16.0±0.20	-	4,000
TCS12	178±1	60.2±0.5	13.0±0.50	13.2±1.50	16.0±0.20	-	4,000

## ▶ Emboss Plastic Tape Specifications

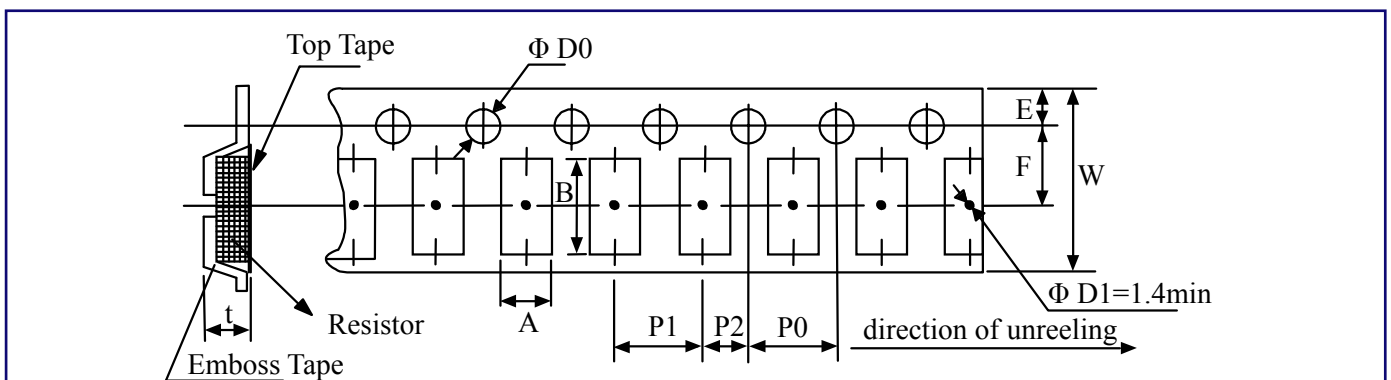

Type	A	B	W	E	F	P0	P1	P2	ΦD0	T
TCS10	2.85±0.10	5.45±0.10	12.0±0.10	1.75±0.10	5.5±0.05	4.00±0.05	4.00±0.10	2.00±0.05	1.50+0.10	1.00±0.20
TCS12	3.40±0.10	6.65±0.10	12.0±0.10	1.75±0.10	5.5±0.05	4.00±0.05	4.00±0.10	2.00±0.05	1.50+0.10	1.00±0.20

## Paper Tape Specifications

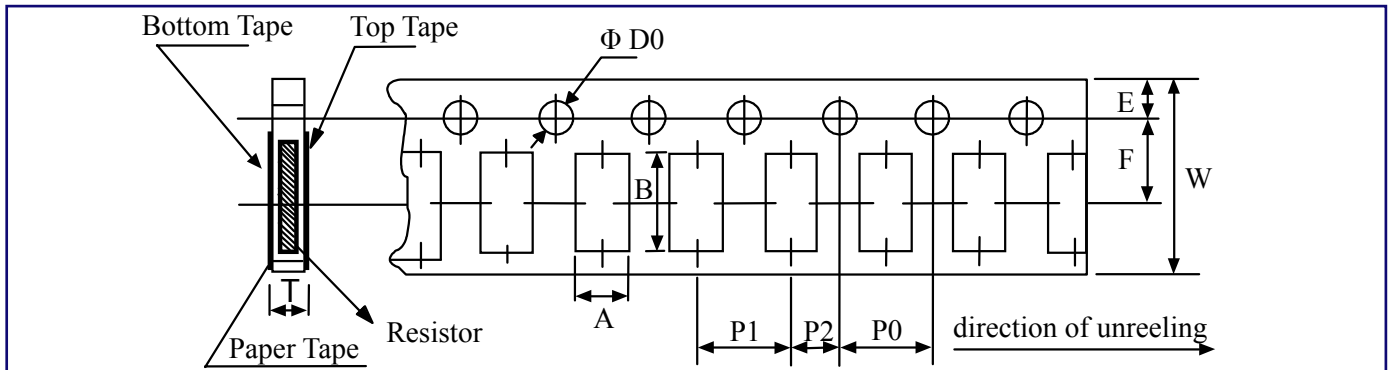

Type	A	B	W	E	F	P0	P1	P2	ΦD0	T
TCS02	0.70±0.05	1.16±0.05	8.00±0.10	1.75±0.05	3.50±0.05	4.00±0.10	2.00±0.10	2.00±0.05	1.55±0.05	0.40±0.03
TCS03	1.10±0.05	1.90±0.05	8.00±0.10	1.75±0.05	3.50±0.05	4.00±0.10	4.00±0.10	2.00±0.05	1.55±0.05	0.60±0.03
TCS05	1.60±0.05	2.37±0.05	8.00±0.10	1.75±0.05	3.50±0.05	4.00±0.10	4.00±0.10	2.00±0.05	1.55±0.05	0.75±0.05
TCS06	2.00±0.05	3.55±0.05	8.00±0.10	1.75±0.05	3.50±0.05	4.00±0.10	4.00±0.10	2.00±0.05	1.55±0.05	0.75±0.05

## How to Order

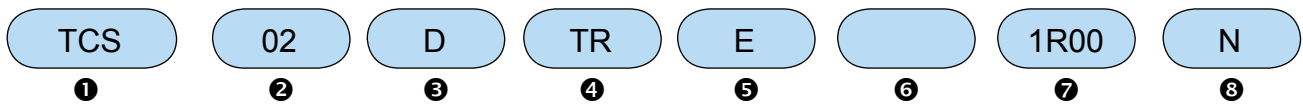

### 1 Part Number

### 2 Dimensions (L×W)

Code	Dimensions (L×W)	
01	0.58×0.29mm	0201
02	1.00×0.50mm	0402
03	1.60×0.80mm	0603
05	2.00×1.25mm	0805
06	3.10×1.55mm	1206
13	3.00×2.50mm	1210
10	5.00×2.50mm	2010
12	6.30×3.10mm	2512
25	3.10×6.30mm	1225
37	3.75×2.00mm	3720
75	7.50×2.00mm	7520

### 3 Resistance Tolerance

Code	Resistance Tolerance
J	±5%
g	±2%
F	±1%

### 4 Packaging

Code	Packaging
TR	Taping Reel
P	Bulk

### 5 TCR

Code	TCR
D	±50PPM/°C
E	±100PPM/°C
F	±200PPM/°C

### 6 Power Rating

Code	Power Rating
S	2W
A	1.5W
T	1W
Q	3/4W
U	1/2W
V	1/4W
W	1/8W

### 7 Resistance

Code	Resistance
R010	0.010Ω
R100	0.100Ω
1R00	1.000Ω

### 8 Marking

Code	Standard Marking
	Standard
N	No Marking

# Low Ohmic Open Air Resistors

## Low Ohmic Open Air (LRA) Resistors Feature Longer Thermal Path

### ▶ Preview

Token's current sense LRA open air resistors are expected to gain wide acceptance in the worldwide market as a result of increased thermal management capabilities.

The LRA Series is designed for applications requiring the transfer of heat away from circuits and solder joints. Available in various values, it is specified for current sensing, feedback, current detection, super low inductance, as well as surge and pulse applications.

The hot spot on the LRA resistor is approximately 0.2 degrees higher than on a typical metal strip chip resistor. This results in an increased thermal path for the LRA, reducing heat transfer into the solder joints and circuits.

The flameproof LRA Series resistors are constructed of a wire resistive element with welded copper leads to prevent solder wicking, which can change the device's resistance value in the circuit by as much as 30%. Because of this, the device is ideal for thermally harsh environments, including automotive and aerospace applications, as well as enclosed, poorly ventilated circuits in applications such as laptop computers.

The LRA Open Air Series feature a reduced pitch, or spacing between the leads on the circuit board (with a corresponding increase in the board mounted profile), when compared to the standard Token LRB Series devices.

The LRA resistors are rated for 1W or 1.5W at 70°C, with resistance values from 0.1Ω to 0.003Ω and tolerances down to ±1%. Operating temperature range is -50°C to 300°C. The LRA Series is available in bulk packaging in 200 increments.

Token will also produce devices outside these specifications to meet customer requirements. A lead-free RoHS-compliant version is available, as is a non-inductive version for high frequency applications. Contact us with your specific needs.



### ▶ Features

- Radial leads.
- Non-inductance.
- Solderable Copper Leads.
- Lead (Pb)-free and RoHS compliant.
- ±1%, ±3%, ±5%, ±10% standard tolerance.
- High stability bare metal element open air style.

### ▶ Applications

- High power AC/DC detection.
- Automotive, Feedback System.
- Residual Battery Power Detection.
- Inverter and Switching Power Supplies
- CPU Drive Control, Power Tool Motor controls.
- Power Supply Shunt, Current Detective, and Current Sensing.

## ► Dimensions (Unit: mm)

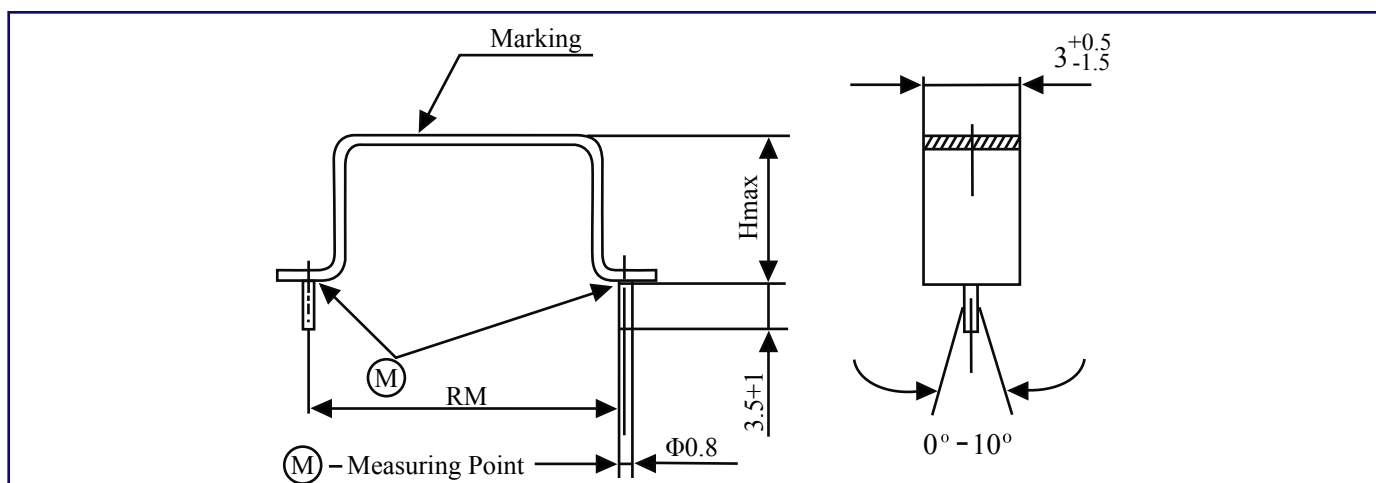

Type	H max.	RM
LRA350-009	6.5	10
LRA351-009	10.5	
LRA352-009	17.0	
LRA351-010	8.0	15
LRA352-010	14.5	
LRA352-010	16.1 $\pm$ 1.0	14.5 $\pm$ 1.0
LRA352-010	17.1 $\pm$ 1.0	14.5 $\pm$ 1.0
LRA352-011	12.0	20

- Construction:
1. The resistive elements consist of a flat metal-band.
  2. Spot welded Cu-terminals ensure high stability of contacts.
  3. Thus, this construction results in a non inductive of both high stability and overload capacity.

## ► Packing Specification

Type	Packaging	Pieces	Pack.-Code
LRA350-009	Bulk	200pcs	Bulk
LRA351-009	Bulk	200pcs	Bulk
LRA351-010			Bulk
LRA352-010	Bulk	200pcs	Bulk
LRA352-011			Bulk

## ▶ Characteristic Specification

Type	LRA	350-009	351-009 351-010	352-009 352-010 352-011
Power rating P70	W	0.5	1.0	1.5
Resistance range	$\Omega$	R003~R051	R004~R068	R006~R10
E-series		E24 $\geq$ R010		
Tolerances	%	$\pm 1, \pm 3, \pm 5, \pm 10$		
Temperature coefficient	PPM	+200~+1200		
Max. Cont. working voltage	VRMS	For all styles		
Insulation voltage (1min.)	VRMS	Non insulated		
Insulation resistance	$\Omega$	Non insulated		
Derating, linear	$^{\circ}\text{C}$	70~300(0W)		
Climatic category		55/200/56		
Temperature range	$^{\circ}\text{C}$	-50~300		
Thermal resistance	KW-1	200	100	70
Failure rate (Total , max, 60% conf. lev.)	$10^{-9} * h^{-1}$	Ca.10, Depends on value		
Endurance (P70, 70,1000h)	[ ]%	$\pm 3.0$		
Damp heat ,steady state(40 $^{\circ}\text{C}$ ,93% r.h.,56d)	[ ]%	$\pm 0.5$		
Climatic sequence	[ ]%	$\pm 0.5$		
Terminal strength	[ ]%	$\pm 0.5$		
Terminal tensile strengths	N	30		
Resistance to soldering heat ( 260 $^{\circ}\text{C}$ ,10s )	[ ]%	$\pm 0.2$ typ.		
Solder ability	s	2.5 Flow time, solder globule test IEC 60068-2-20-T		
Making		Value imprinted		

## ▶ How to Order

LRA351-009

❶

R024

❷

J

❸

Bulk

❹

### ❶ Part Number

### ❷ Resistance Value ( $\Omega$ )

Code	Resistance Value
R020	0.020 $\Omega$
R022	0.022 $\Omega$
R024	0.024 $\Omega$
R100	0.100 $\Omega$

### ❸ Tolerance

Code	Tolerance
F	$\pm 1\%$
G	$\pm 2\%$
J	$\pm 5\%$
K	$\pm 10\%$

### ❹ Pack. -Code

Code	
p	Bulk

*Back to 1st Page - Low Ohmic Open Air Resistors (LRA)*

# Open Air Low Resistance Resistors

**Token's Low Resistance, Low Inductance,  
Open-Air Resistor is Alternative Shunts (LRB)**



## ▶ Preview

Developed for current sensing and shunt applications, Token's LRB series of bare element resistors have a precision alloys (Ni-Cu) element welded construction. Built-in stand-offs and standard spacings make for easy mounting.

The bare metal element design allows for maximum cooling via airflow, forcing less heat into the PCB. The flameproof construction offers values down to 2mΩ with low inductance. Customer can specify resistance range designed to satisfy challenging and specific technical requirements.

These factors make the LRB Series an outstanding choice for all types of high current power supplies and power applications requiring a robust part that is impervious to most environmental stresses. The device is ideal for current limited, Current balance, and sampling sense in power supplier. It takes on the capability of high overload, and the function easily welding and non inductance as well.

The LRB Series is available in bulk packaging and is RoHS compliant and lead free. For non-standard technical requirements and special applications, please contact us with your specific needs.

## ▶ Features

- Low inductance.
- High stability open-air style.
- Precision alloys resistive element.
- Lead (Pb)-free and RoHS compliant.
- Standard tolerance  $\pm 3\%$ ,  $\pm 5\%$ ,  $\pm 10\%$ .
- Radial leads, low resistance value 2 mΩ ~ 50 mΩ.

## ▶ Applications

- CPU Drive Control.
- Power Tool Motor controls.
- Automotive, Feedback System.
- Inverter and Switching Power Supplies.
- Power Supply Shunt, Current Detective.
- Residual Battery Power Detection, and Current Sensing.

## ▶ Dimensions (Unit: mm)

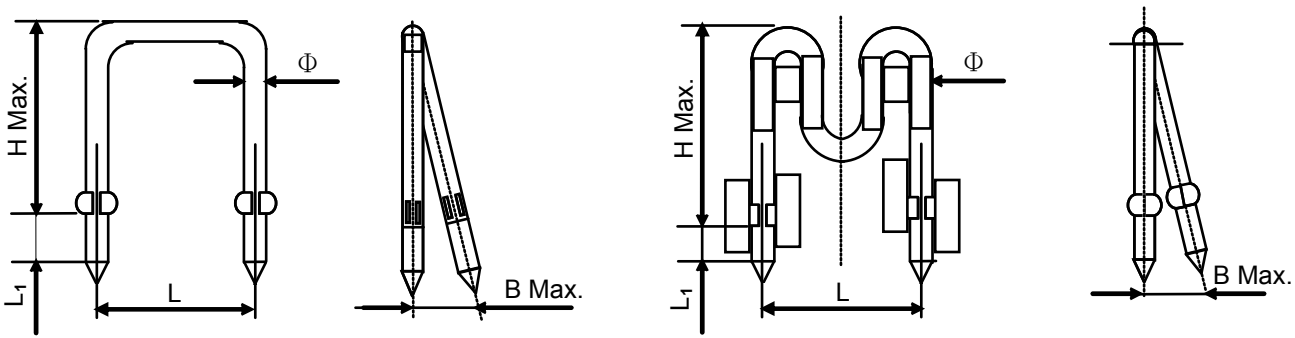

RM (mm)	H Max. (mm)	B Max. (mm)	Ø (mm)	L1 (mm)
5 ~ 50	20	1	5 ~ 29	3±0.5

## ▶ Specification

Type	Diameter Ø (mm)	Rated Current (A)	Resistance Range (mΩ)	Tolerance (%)	Temperature Coefficient (ppm/°C)	Temperature Range (°C)
LRB-05	0.5	2.5	20~50	±3%(H) ±5%(J) ±10%(K)	±50 ~ ±100	-55 ~ +85
LRB-06	0.6	3.0	20~50			
LRB-07	0.7	4.0	20~50			
LRB-08	0.8	4.5	20~50			
LRB-09	0.9	5.0	10~50			
LRB-10	1.0	5.5	10~30			
LRB-11	1.1	6.0	5~20			
LRB-12	1.2	7.0	5~20			
LRB-13	1.3	7.5	5~20			
LRB-14	1.4	8.0	5~20			
LRB-15	1.5	9.0	5~20			
LRB-16	1.6	9.5	5~15			
LRB-18	1.8	11	3~10			
LRB-20	2.0	12	2~8			
LRB-23	2.3	14	2~8			
LRB-25	2.5	17	2~5			
LRB-29	2.9	21	2~5			

## How to Order

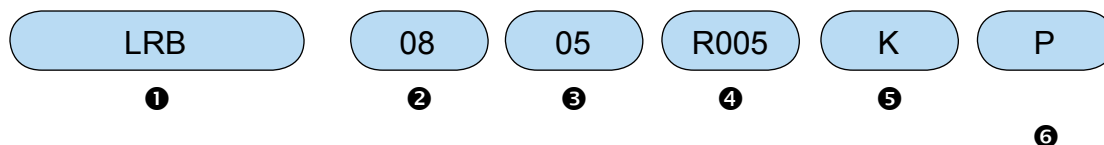

① Part Number: LRB

② Diameter Ø

Code	Diameter Ø
05	0.5 mm
06	0.6 mm
07	0.7 mm
08	0.8 mm
09	0.9 mm
10	1.0 mm
11	1.1 mm
12	1.2 mm
13	1.3 mm
14	1.4 mm
15	1.5 mm
16	1.6 mm
17	1.7 mm
18	1.8 mm
20	2.0 mm
23	2.3 mm
25	2.5 mm
29	2.9 mm

③ Leads Pitch RM (mm)

Code	Leads Pitch RM (mm)
05	0.5 mm
10	10 mm
15	15 mm
20	20 mm
25	25 mm
30	30 mm
35	35 mm
40	40 mm
45	45 mm
50	50 mm

④ Resistance Value (Ω)

Code	Resistance Value (Ω)
05	0.5 mm
10	10 mm
15	15 mm

⑤ Tolerance %

Code	Tolerance %
H	±3%
J	±5%
K	±10%

⑥ Package-Code

Code	Package-Code
P	Bulk

*Back to 1st Page - Open Air Low Resistance Resistors (LRB)*

## Open Air Current Sense Resistor

Token's "tight pitch" version of its open air metal element current sense resistor (OAR) need less PCB space.

### ▶ Preview

In response to requests from power electronics design engineer with the means to squeeze more current-sensing capability into crowded power supply designs, Token Electronics has developed a "tight pitch" version of its open air metal element current sensing resistor with ratings as high as 5W in a reduced PC board footprint and longer thermal path.

Designated the OAR Series, these open-air through-hole devices offer a high current, flameproof alternative to conventional axial devices and flat chips for current-sense circuits where PC board space is at a premium. The resistor's footprint is reduced by extending the height of the device above the board, thus keeping the resistor element's "hot spot" safely off the PC board and providing for increased air circulation under it, which in turn provides increased heat dissipation and cooler operation.

The OAR devices with increased height improve cooling efficiency, and because many power supply designs are already tightly-packed at the PC board level, the additional height does not create any profile issues. The OAR series resistors feature a reduced pitch, or spacing between the leads on the circuit board with a corresponding increase in the board mounted profile.

The OAR Series resistors are power rated for 1W, 2W, 3W, or 5W at 85°C, with resistance values from 0.05Ω to 0.005Ω, with tolerances down to ±1%. They feature TCRs as low as ±50ppm/°C and inductance values in the single-digit nanohenry range (10 nH Max.). Operating temperature range is -40°C to +125°C. The flameproof OAR resistors are constructed of a wire resistive element with welded copper leads to prevent solder wicking, which can change the device's resistance value in the circuit by as much as 30%.

The OAR Series is available in bulk packaging and is RoHS compliant and lead free. For non-standard technical requirements and special applications, please contact us with your specific needs.

### ▶ Features

- High stability open-air style.
- Precision alloys resistive element.
- Lead (Pb)-free and RoHS compliant.
- Standard tolerance ±1%, ±2%, ±5%.
- Low inductance. Solderable copper leads (60/40).
- Radial leads, low resistance value 0.05Ω ~ 0.005Ω.

### ▶ Applications

- CPU Drive Control.
- Power Tool Motor controls.
- Automotive, Feedback System.
- Inverter and Switching Power Supplies.
- Power Supply Shunt, Current Detective.
- Residual Battery Power Detection, and Current Sensing.



## ► Dimensions (Unit: mm)

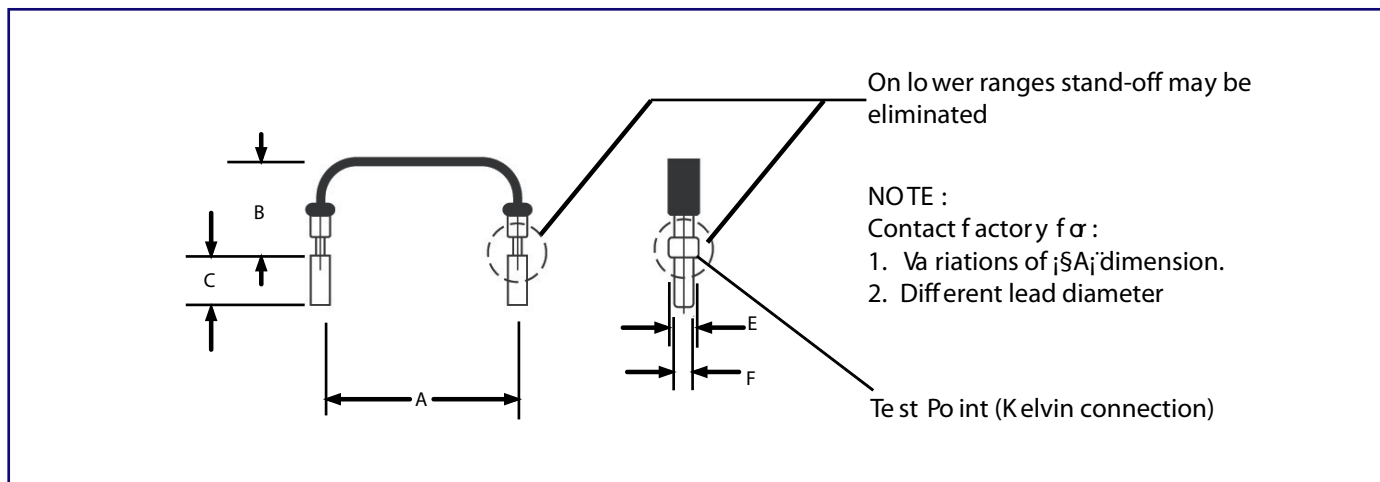

Type	Dimensions (Unit: mm)				
	A±1	B±3	C±0.8	E±0.3	F±0.1
OAR-1	10	10	3.5	1.6	1.0
OAR-2	15	15	3.5	1.6	1.0
OAR-3	20	20	3.5	1.6	1.0
OAR-5	20	20	3.5	1.6	1.0

## ► Specification

Type	Power Rating @ 85°C (W)	Resistance Range (mΩ)	Tolerance (±%)	Temperature Coefficient TCR (ppm/°C)	Inductance (nH)
OAR-1	1	R005~R05	±1% ±2% ±5%	±50	10 Max.
OAR-2	2	R005~R05			
OAR-3	3	R005~R05			
OAR-5	5	R005~R01			

## ► Characteristic Specification

Test Items	Test Method	Specification
Load Life	1000 hours @ 25°C	ΔR/R < 1%
Moisture Test	no load for 1000 hours	ΔR/R < 1%
Temperature Cycling	-40°C to +125°C for 1000 cycles	ΔR/R < 1%
Operating Temperature		-40°C to +125°C

## How to Order

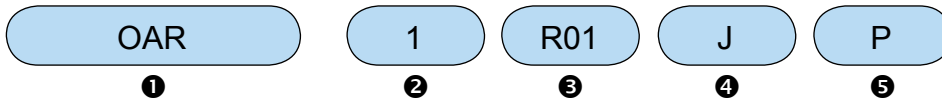

❶ Part Number: OAR

❷ Rated power

Code	Rated power
1	1w
2	2w
3	3w
5	5w

❹ Tolerance %

Code	Resistance Value ( $\Omega$ )
F	$\pm 1\%$
G	$\pm 2\%$
J	$\pm 5\%$

❸ Resistance Value ( $\Omega$ )

Code	Resistance Value ( $\Omega$ )
R005	$0.005\Omega$
R01	$0.01\Omega$
R05	$0.05\Omega$

❺ Package-Code

Code	Resistance Value ( $\Omega$ )
P	Bulk

*Back to 1st Page - Open-Air Current Sensing Resistors (OAR)*

# Current Shunt Resistors

**Token's Shunt Resistors (FL)  
for high-current applications aid precision measurement.**

## ▶ Preview

Current shunt resistors are low resistance precision resistors used to measure AC or DC electrical currents by the voltage drop those currents create across the resistance. Sometimes called an ammeter shunt, it is a type of current sensor.

A wide range of precision shunts, designed for use with kilowatt-hour meters and other high-current applications where a high level of accuracy is required, is now available from Token Electronics.

The interchangeable shunts (FL) are used to multiply the measuring range of measuring instruments and designed for PCB and busbar mounting, are manufactured from electron beam welded copper and manganin, and have low temperature coefficients. Featuring low inductance values, shunts FL series can handle permanent currents of up to 10000A at voltage 75 mV.

FLQ-54 type shunt is made of precision alloy board. It's copper terminals spot welded by silver alloy ensure extremely high electric capability. The construction provides a kind of excellent stability and high overloaded ability non-inductive resistor, applied widely as current limited, current balance or sampling sense in communication system, electric equipment and auto-controlling electrical circuit.

The FL Series is available in bulk packaging and is RoHS compliant and lead free. For non-standard technical requirements and special applications, please contact us with your specific needs.



## ▶ Power Rating : Watts (W) = Current (I) x Resistance Value (R)

- The heat produced is power measured in Watts (W).
- In practice current shunts are often rated to be used continuously at only 2/3 of their "rated current".
- Because current shunts are resistors and dissipate heat from the current flowing through them, they get hot.
- Since that heat can change their resistance and even permanently damage the shunt, current shunts are often given a power rating or a derating factor.

## ▶ Calculate Current : Current (I) = Voltage (V) / Resistance Value (R)

- Then knowing the resistance of the current shunt you can calculate the current using Ohm's law.
- By inserting a current shunt into a circuit whose current you want to measure you can find the current by measuring the voltage drop across the shunt.

▶ FL-2 (5A-100A, Unit: mm)

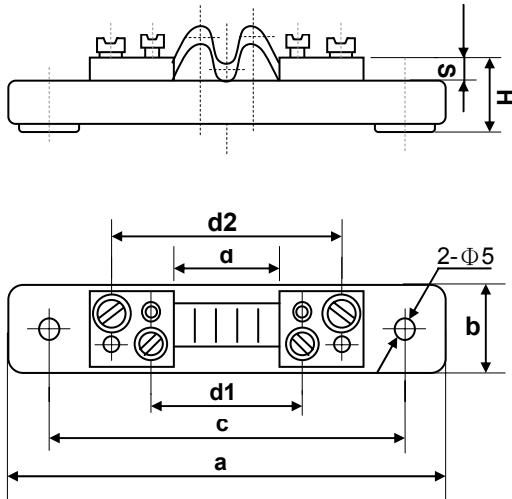

**5A ~ 50A**

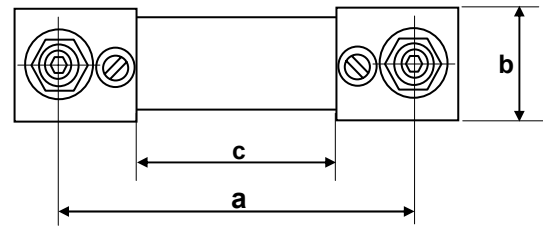
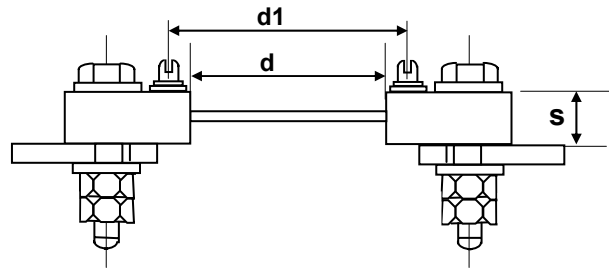

**75A ~ 100A**

Rating Current (A)	Dimensions (Unit: mm)										High Current Bolt (mm)-PC (Option)	Shunt Voltage Bolt (mm)-PC (Option)
	a	c	b	c1	c2	H	S	d	d1	d2		
5	120	100	20			15	5	30	42	60	M5x6-2	M5x6-2
10	120	100	20			15	5	30	42	60	M5x6-2	
15	120	100	20			15	5	30	42	60	M5x6-2	
20	120	100	20			15	5	30	42	60	M5x6-2	
30	120	100	20			15	5	30	42	60	M5x6-2	
50	120	100	20			15	5	30	42	60	M5x6-2	
75	104	85	22			22	10	40	53		M8x35-2	
100	104	85	22			22	10	40	53		M8x35-2	

► FL-2 Dimensions (150A-1000A, Unit: mm)

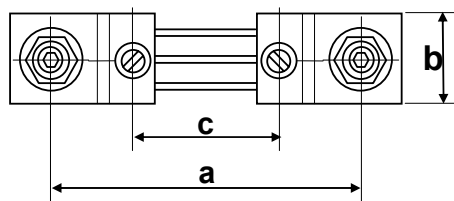
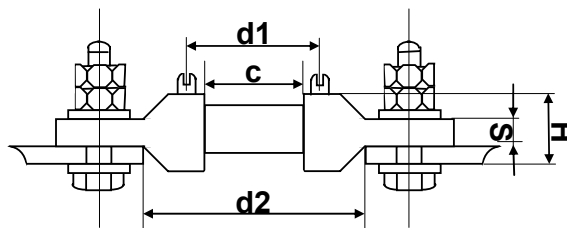
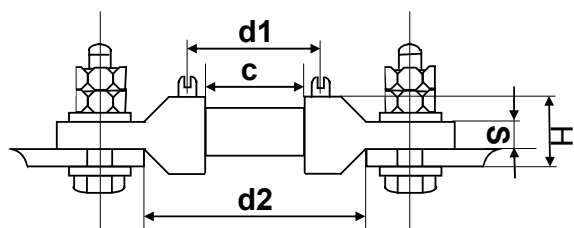

**150A ~ 600A**

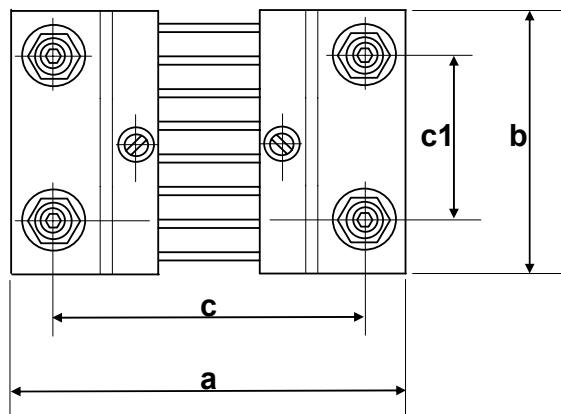

**750A ~ 1000A**

Rating Current (A)	Dimensions (Unit: mm)										High Current Bolt (mm)-PC (Option)	Shunt Voltage Bolt (mm)-PC (Option)
	a	c	b	c1	c2	H	S	d	d1	d2		
150	116	85	22			22	6	30	39	54	M8x35-2	M5x6-2
200	116	85	22			22	6	30	39	54	M8x35-2	
250	126	100	26			22	6	40	49	64	M10x35-2	
300	126	100	26			22	6	40	49	64	M10x35-2	
400	126	100	38			22	6	40	49	64	M10x35-2	
500	126	100	45			22	6	40	49	64	M10x35-2	
600	126	100	62			22	6	40	49	64	M10x35-2	
750	126	100	76	50		22	6	40	49	64	M10x35-4	
1000	126	100	95	50		22	6	40	49	64	M10x35-4	

▶ FL-2 Dimensions (1500A-10000A, Unit: mm)

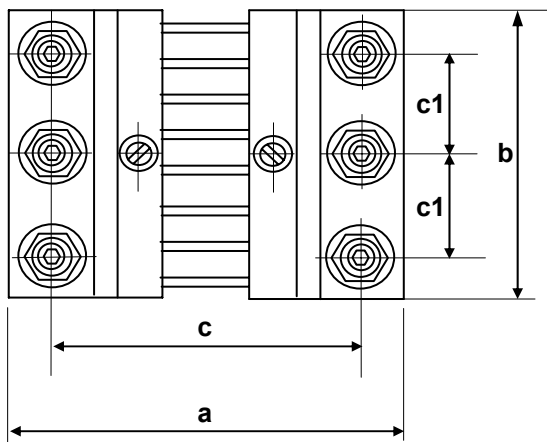
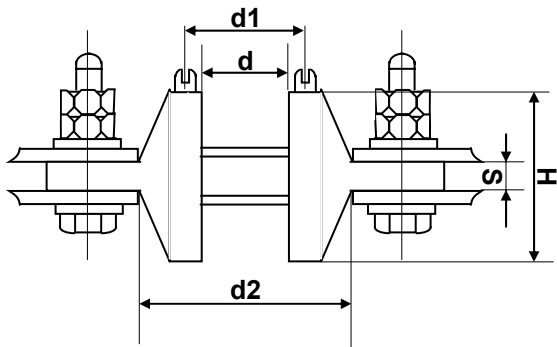

**1500A ~ 3000A**

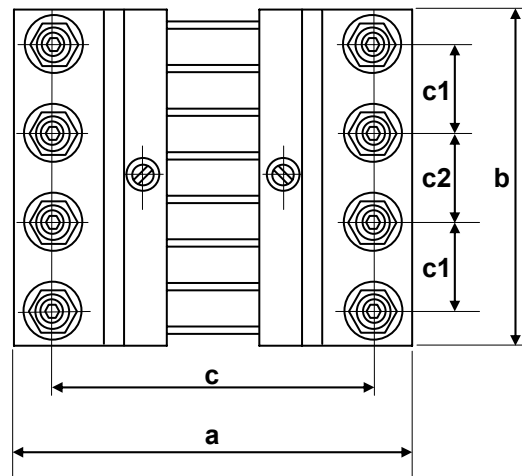

**4000A ~ 10000A**

Rating Current (A)	Dimensions (Unit: mm)										High Current Bolt (mm)-PC (Option)	Shunt Voltage Bolt (mm)-PC (Option)
	a	c	b	c1	c2	H	S	d	d1	d2		
1500	190	160	95	50		22	6	40	52	64	M12x60-4	M5x6-2
2000	190	160	95	50		22	6	40	52	64	M12x60-4	
2500	190	160	110	50		100	13	40	52	84	M12x60-4	
3000	190	160	145	2-50		100	13	40	52	84	M12x60-6	
4000	190	160	195	2-50	55	100	13	40	52	84	M16x80-8	
5000	284	220	195	2-50	55	150	18	40	52	88	M16x80-8	
6000	284	220	210	2-50	80	150	18	40	52	88	M16x80-8	
7500	290	220	320	3-50	2-60	150	18	40	52	88	M16x80-12	
10000	290	220	400	3-50	2-90	150	18	40	52	88	M16x80-12	

► FL-13 Dimensions (30A-75A, Unit: mm)

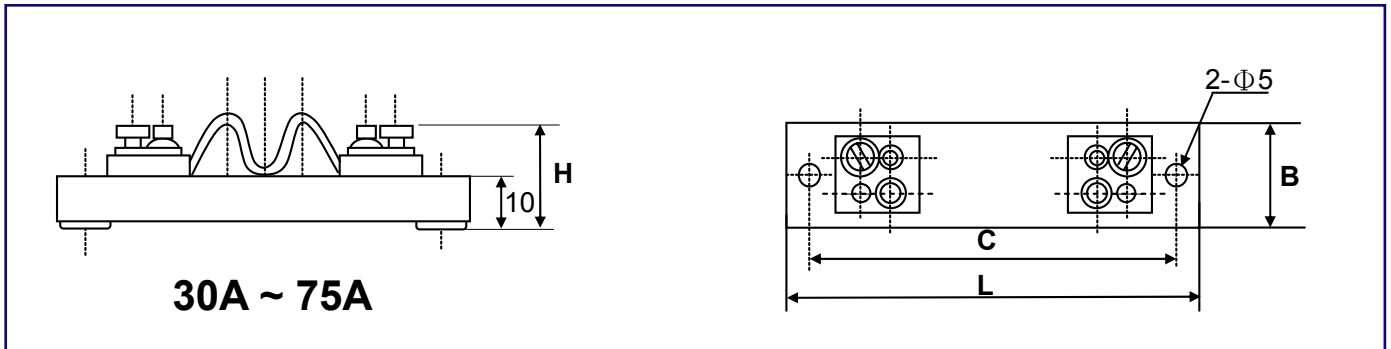

Voltage (mV)	Rating Current (A)	Dimensions (Unit: mm)			Mounting size (mm)	
		L	B	H	C	Bolt
75mV	30A	100	20	21	85	M5
75mV	50A	130	14	30	85	M8
75mV	75A	130	14	30	85	M8

## ▶ FL-13-A Dimensions (100A-1000A, Unit: mm)

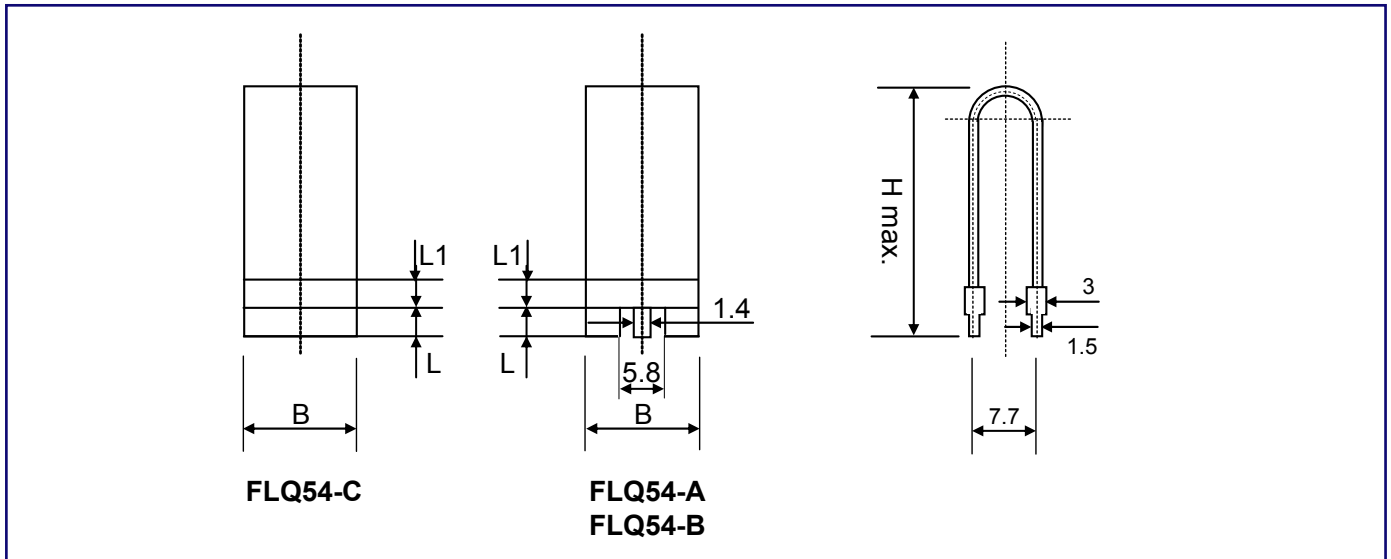

Type	Dimensions (Unit: mm)				Style of terminal
	H max.	B	L	L1	
FLQ54-A	37	18	3	3	6
FLQ54-B	60	30	5	5	6
FLQ54-C	32	15	3	3	2

## ▶ FLQ54 Technical Specifications (30A-100A)

Type	Rated Current (A)	Rated Voltage Drop (mV)	Nominal Resistance (mΩ)	Accuracy Class	Temperature Range (°C)	Temperature Coefficient (ppm/°C)
FLQ54-A	30	50	1.6667	0.5	-55 ~ +85	±25 ppm/°C
FLQ54-A	50	50	1.0000			
FLQ54-A	60	50	0.8333			
FLQ54-B	60	50	0.8333			
FLQ54-B	75	50	0.6667			
FLQ54-B	100	50	0.5000			
FLQ54-C	30	45	1.5000			
FLQ54-C	60	45	0.7500			

## ▶ Current Shunts (FL-2, FL-13, FL-13-A) Characteristic Specification

Test Items	Specification
Voltage Drop	50mV, 60mV, 75mV, 100mV.
Accuracy Class	0.5 for 5~40000A; 1 for 5000~6000A
Over Rating Capacity	120% of rated current for 2 hours.
Ambient Conditions	Temperature: -40~+60°C; relative humidity: ≤95% 35°C
Giving Out Heat When Loaded	Not be more than 80°C after temperature rise gets steady; not be more than 80°C at rated current of over 50A.
Capacity to Withstand Mechanical Force	It is capable of withstanding the transport bumping at acceleration of 70m/S <sup>2</sup> and shock frequency of 80-20 times/min for 5 hours.

## ▶ How to Order

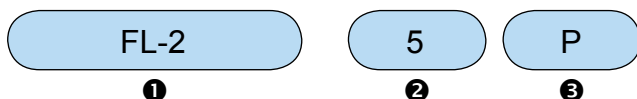

① Part Number: FL-2, FL-13, FL-13-A, FLQ54-A, FLQ54-B, FLQ54-C

② Rating Current (A)

Code	Rating Current (A)
5	5A
10	10A
200	200A
750	750A

③ Package-Code

Code	Package-Code
P	Bulk

[Back to 1st Page - Current Shunt Resistors \(FL\)](#)

# Kelvin Four Terminal Resistors

**Token (LSQ) Family Four Terminal Resistors handle high-wattage applications**

## ▶ Preview

Providing ultralow resistance values (to 0.01 ohm) for relatively high current requirements, new four-terminal cement filling resistors from Token combine the advantages of a Kelvin configuration with PC board mounting capability.

The Kelvin (or four-terminal) configuration enables current to be applied through two opposite terminals and a sensing voltage to be measured across the other two terminals, eliminating the resistance and temperature coefficient of the terminals for a more accurate current measurement.



The four terminal resistors are a new version of Token's (LSQ) Current Sense Family Series which was specially designed for use in a Kelvin configuration where a current is applied through two opposing leads and sensing voltage is measured across the other two leads. Token LSQ series is specifically designed for low resistance applications requiring the highest accuracy and temperature stability.

The advantages of Kelvin configuration enable the resistance and temperature coefficient of the leads to be effectively eliminated. The need to connect to the leads at precise test points is eliminated, allowing for tighter tolerance on the end application. Also results in a lower temperature coefficient of resistance and lower self-heating drift which may be experienced on two-terminal resistors.

Token will also produce low ohm resistor LSQ series outside these specifications to meet customer requirements. Contact us with your specific needs.

## ▶ Features

- Welded & fireproof construction.
- Superior anti-surge capability & Low TCR.
- Thermal conductivity and moisture resistance.
- Special inorganic potting construction provides high moisture resistance and thermal conductivity.
- 4 leads for Kelvin connection with extremely low resistance values.

## ▶ Applications

- Automatic Test Equipment.
- Current Sensing Application.
- High Precision Instrumentation.
- Industrial, Medical and Military.
- Measurement Instrumentation.

## ▶ (LSQ-A) Specification & Dimensions (Unit: mm)

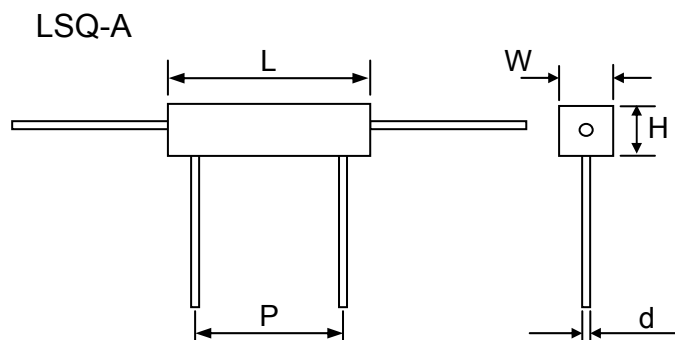

Type	Power (Watts)	Resistance Range ( $\Omega$ )	Dimensions (Unit: mm)				
			L	W $\pm$ 1	H $\pm$ 1	P $\pm$ 1	d $\pm$ 0.5
LSQ-A-3	3	R01~R1	22 $\pm$ 1.0	8	8	14	0.8
LSQ-A-5	5	R01~R1	22 $\pm$ 1.5	9.5	9.5	14	0.8
LSQ-A-7	7	R01~R1	35 $\pm$ 2.0	9.5	9.5	25	0.8
LSQ-A-10	10	R01~R1	48 $\pm$ 2.0	9.5	9.5	36	0.8
LSQ-A-15	15	R01~R1	48 $\pm$ 2.0	12.5	12.5	36	0.8

## ▶ (LSQ-B) Specification & Dimensions (Unit: mm)

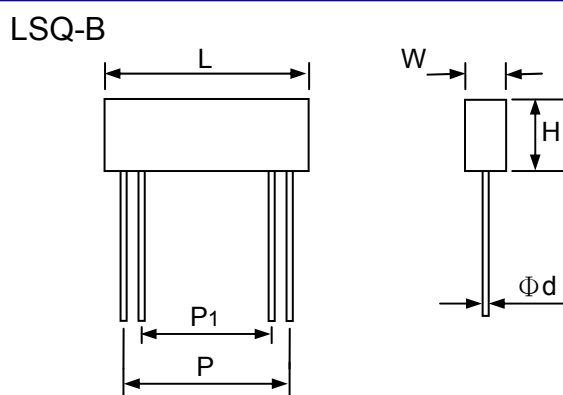

Type	Power (Watts)	Resistance Range ( $\Omega$ )	Dimensions (Unit: mm)					
			L $\pm$ 2	W $\pm$ 1	H $\pm$ 1	P $\pm$ 1	P1 $\pm$ 1	d $\pm$ 0.5
LSQ-B-5	5	R01~R1	26	5	10	20	12	0.8

## ▶ (LSQ-C) Specification & Dimensions (Unit: mm)

LSQ-C

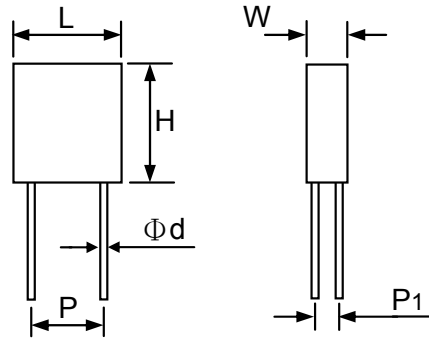

Type	Power (Watts)	Resistance Range ( $\Omega$ )	Dimensions (Unit: mm)					
			$L \pm 2$	$W \pm 1$	$H \pm 1$	$P \pm 1$	$P_1 \pm 1$	$d \pm 0.5$
LSQ-C-10	10	R01~R1	18	10.5	20	12	5	1.0

## ▶ Power Derating Curve

**Power Derating Curve**

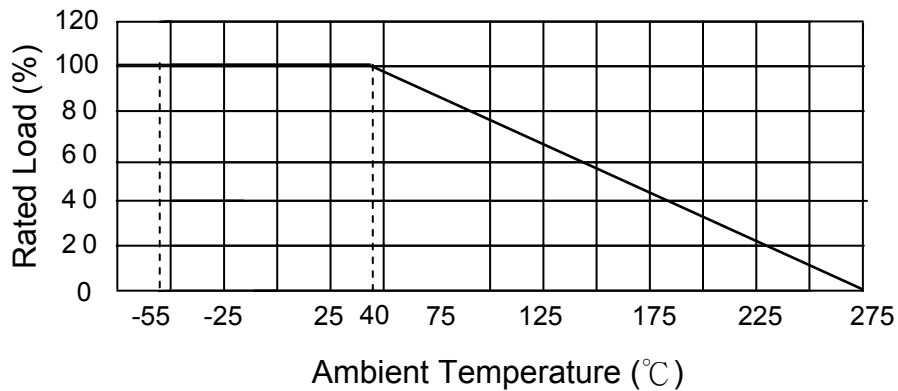

## ▶ Characteristic Specification

### KELVIN ELECTRICAL CONNECTION

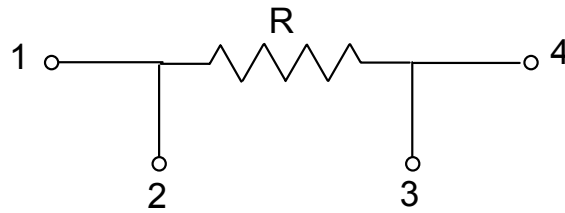

TERMINALS 2 & 3 CURRENT TRACES.  
TERMINALS 1 & 4 SENSE TRACES.

Test Items	Test Method	Specification
Resistance Tolerances		D(±0.5%), F(±1%), G(±2%), J(±5%)
Temperature Coefficients		±100 ppm/°C
Operating Temperature Range		-55°C~275°C
Maximum Working Voltage		(P40°C x R)1/2
Terminal Tensile Strength	50N, 10s	ΔR≤±1.0%R
Withstand Voltage	1000V, 1 Min.	No damage on the appearance.
Short Time Overload	5 times rated power, 5s	ΔR≤±4.0%R
Thermal Shock	-55°C~+275°C, 5 cycles, 30 min.	ΔR≤±5.0%R
Load Life	40°C, 1000h 1.5 hours on, 0.5 hours off.	ΔR≤±5.0%R

## ▶ How to Order

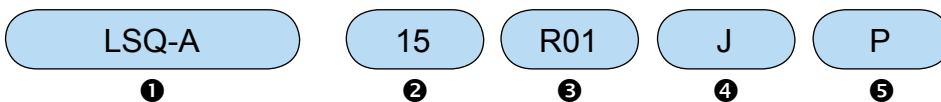

❶ Part Number: LSQ-A, LSQ-B, LSQ-C

❷ Rated power

Code	Rated power
3	3 Watt
5	5 Watt
7	7 Watt
10	10 Watt
15	15 Watt

❸ Resistance Value (Ω)

Code	Resistance Value (Ω)
R01	0.01Ω
R05	0.05Ω
R1	0.1Ω

❹ Tolerance %

Code	Tolerance %
J	±5%

❺ Package-Code

Code	Package-Code
P	Bulk

*Back to 1st Page - Kelvin Four Terminal Resistors (LSQ)*

# Open Air Four-terminal Resistors

**Token's Open Air Four-terminal resistors (LRD) tackle current sensing applications**

## ▶ Preview

Always preferred in current sense applications, Token's LRD Series range is available in the 1W, 3W, 5W, 7W and 10W packages, resistance values down to 0.001 ohm, with tolerances as tight as 0.50% and TCRs of 50ppm standard.

The Kelvin (four-terminal) configuration enables current to be applied through two opposite terminals and a sensing voltage to be measured across the other two terminals, eliminating the resistance and temperature coefficient of the terminals for a more accurate current measurement.

With up to 10W power rating and TCRs as low as 50ppm/°C, the LRD Series resistors deliver excellent performance, making them ideal for a variety of applications. The resistor is constructed using a low-resistance, low-inductance, high-impulse proprietary metal element that gives the device its extended power and temperature ratings.

Continually upgrading its resistors to take advantage of modern technologies and manufacturing methods, Token is now able to offer complete ranges of products which meet the RoHS requirements and in addition to detailing these, the component selector also provides designers with a comprehensive selection of application notes.

The LRD devices can be manufactured to custom length/width for use as a current shunt. Token will also produce outside these specifications to meet customer requirements. Contact us with your specific needs.



## ▶ Features

- Low inductance.
- 4 leads for Kelvin connection.
- Decimal marked, silicone coated.
- Tinned copper terminal for easy soldering.
- Radial, self-supporting, design is ideal for PC board mounting.

## ▶ Applications

- Surge/Pulse Applications.
- Current Sensing Application.
- Feed Back & Motor Control.
- High Precision Measurement Instrumentation.

## ► Specification & Dimensions (Unit: mm)

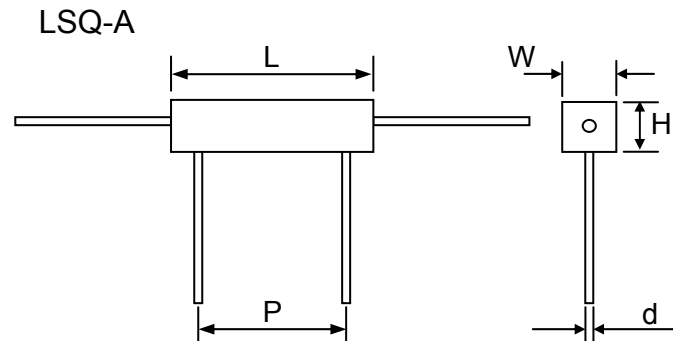

Type	Rating Wattage	Resistance Range (mΩ)	Tolerance (%)	TCR (ppm/°C)
LRD-1	1W	1 ~ 10 mΩ	D(±0.5%) F(±1%) G(±2%) J(±5%)s	±50 ppm/°C ±100 ppm/°C
LRD-3	3W	1 ~ 10 mΩ		
LRD-5	5W	0.5 ~ 5 mΩ		
LRD-7	7W	0.3 ~ 3 mΩ		
LRD-10	10W	0.1 ~ 1 mΩ		

## ► Power Derating Curve

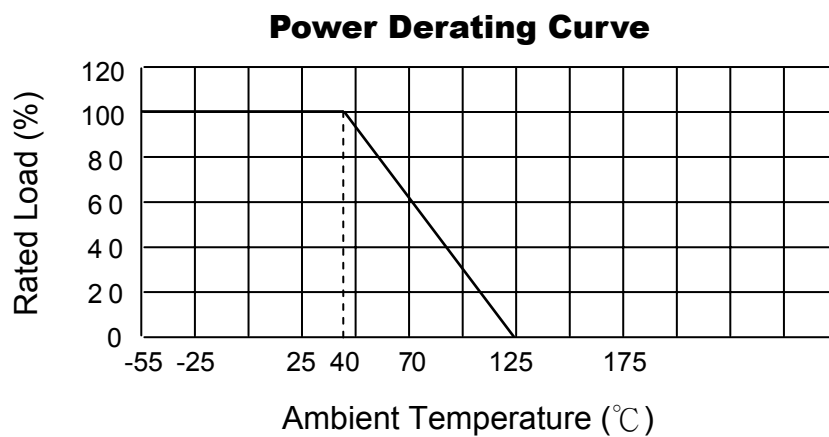

## ▶ Characteristic Specification

### KELVIN ELECTRICAL CONNECTION

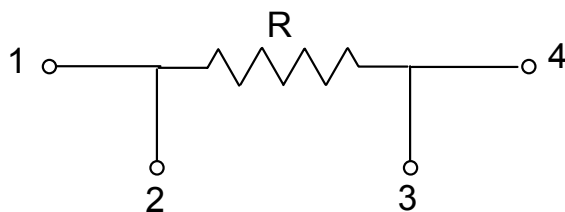

TERMINALS 2 & 3 CURRENT TRACES.  
TERMINALS 1 & 4 SENSE TRACES.

Test Items	Test Method	Specification
Operating Temperature Range		-55°C ~ 125°C
Maximum Working Voltage		(P40°C x R)/2
Terminal Tensile Strength	50N, 10s	$\Delta R \leq \pm 1.0\%R$
Withstand Voltage	1000V, 1 Min.	No damage on the appearance.
Short Time Overload	5 times rated power, 5s	$\Delta R \leq \pm 4.0\%R$
Thermal Shock	-55°C ~ +125°C, 5 cycles, 30 min.	$\Delta R \leq \pm 5.0\%R$
Load Life	70°C, 1000h 1.5 hours on, 0.5 hours off.	$\Delta R \leq \pm 5.0\%R$

## ▶ How to Order

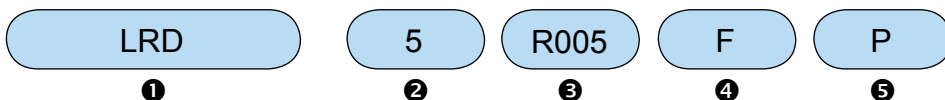

❶ Part Number: LRD

❷ Rated power

Code	Rated power
1	1 Watt
3	3 Watt
5	5 Watt
7	7 Watt
10	10 Watt

❹ Tolerance %

Code	Tolerance %
D	$\pm 0.5\%$
F	$\pm 1\%$
G	$\pm 2\%$
J	$\pm 5\%$

❸ Resistance Value ( $\Omega$ )

Code	Resistance Value ( $\Omega$ )
R005	0.005 $\Omega$
R05	0.05 $\Omega$
R1	0.1 $\Omega$

❺ Package-Code

Code	Package-Code
P	Bulk

*Back to 1st Page - Open Air Four-terminal Resistors (LRD)*

# Low Ohm Current Sensing Resistors

## Token (LPS) Family Offers A Variety of Possibilities for Shunt-Resistors

### ▶ Preview

Token's current sense LPS family for shunt-resistors is expected to gain wide acceptance in the worldwide market as a result of offering a variety of possibilities.

The U-shaped semi-customized LPS family for direct board mounting is specified for current sensing, feedback, current detective, super low inductance, as well as surge and pulse applications. LPS family Available in very low ohm ( $0.002\Omega \sim 0.05\Omega$ ) and high power ( $1W \sim 5W$ ).

The dimensions of the semi-customized final unit is designed in accordance with the applicational requirements of resistance value and required power rating. Token's LPS series can be manufactured with 2 or 4 soldertags (terminals). The LPS type B with 2 soldertags (1 pin on each side) is a standard part of LPS series and type A with 4 terminals (2 pin on each side) is used either for Kelvin connections or for high current applications. Depending from the alloy material's thickness, one terminal contact on each side can carry up to 50A ( $A \text{ (Current)} = (W \text{ (Power)} / \Omega \text{ (Resistance)})^{1/2}$ ), so a 4-terminal part can carry 100A (ask Token factory).

Operating temperature range is  $-50^{\circ}\text{C}$  to  $300^{\circ}\text{C}$  with tolerances  $\pm 2\%$ ,  $\pm 5\%$ , and  $\pm 10\%$ .

Token will also produce low ohm resistor LPS series outside these specifications to meet customer requirements. Contact us with your specific needs.



### ▶ Features

- Radial leads.
- Non-inductance.
- Solderable Copper Leads.
- Lead (Pb)-free and RoHS compliant.
- $\pm 2\%$ ,  $\pm 5\%$ ,  $\pm 10\%$  standard tolerance.
- High stability bare metal element open air style.

### ▶ Applications

- High power AC/DC detection.
- Automotive, Feedback System.
- Residual Battery Power Detection.
- Inverter and Switching Power Supplies
- CPU Drive Control, Power Tool Motor controls.
- Power Supply Shunt, Current Detective, and Current Sensing.

## ► Dimensions (Unit: mm)

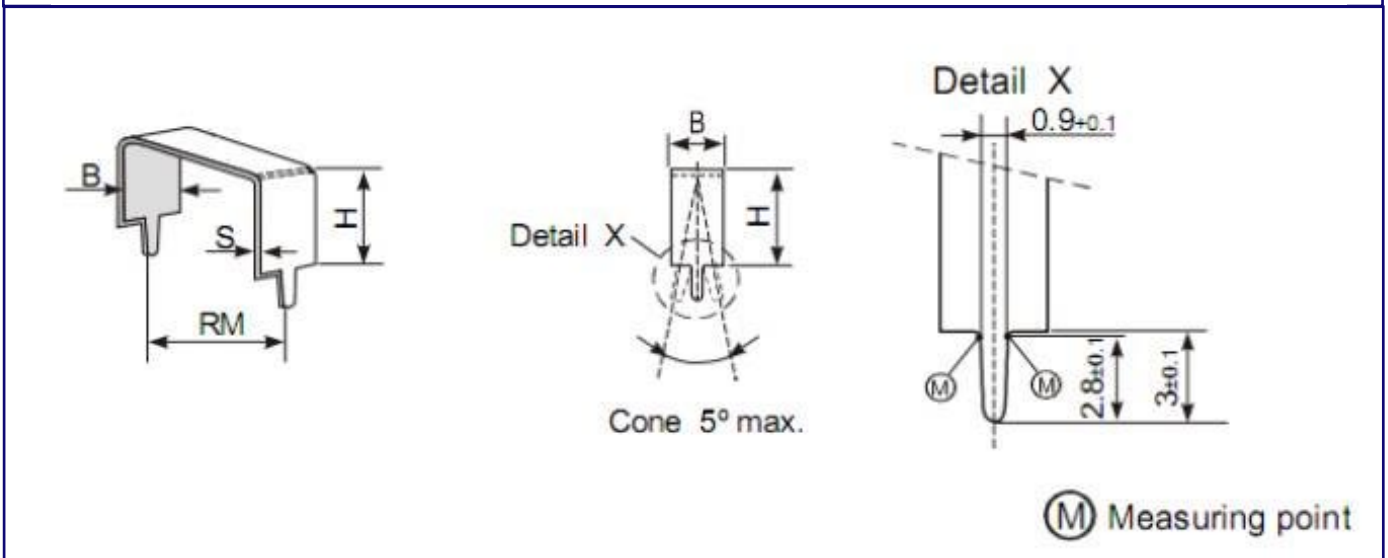
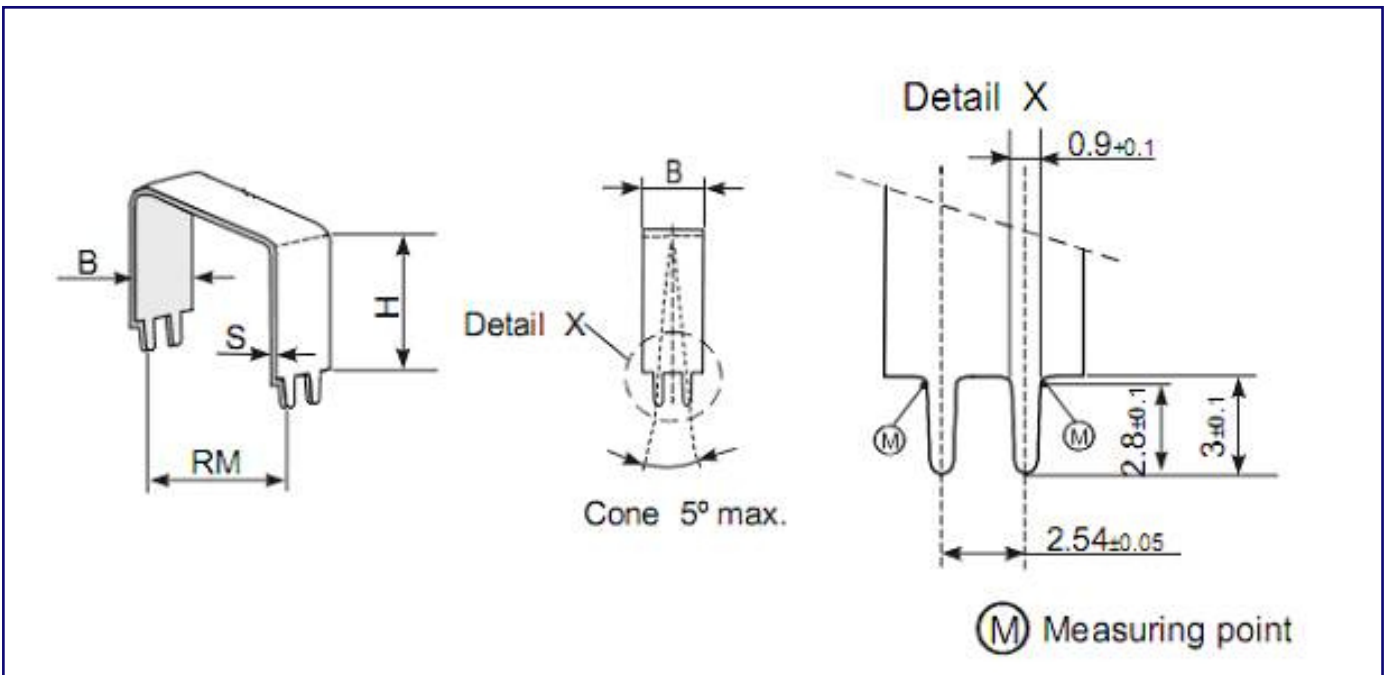

Type	Power (Watts)	Resistance Range ( $\Omega$ )	RM (mm)	H (mm) Max.
LPS359-008	1	R005~R05	5 ~ 30	20.0
LPS359-009	2	R005~R02		
LPS359-010	3	R003~R01		
LPS359-011	5	R002~R005		

Construction: 1. W, T and H depend on material, resistance value and required power rating.

2. RM: 5~30 mm, preferably in 5 mm-steps. Special varieties on request.

3. M: Measuring point.

## ▶ Characteristic Specification

Test Items	Specification
Resistance range	R002~R05
Tolerances	±2%, ±5%, ±10%
Temperature coefficient	Upon request
Insulation voltage	Non insulated
Insulation resistance	Non insulated
Derating, linear	70~300°C(0W)
Climatic category	55/155/21
Temperature range	-50~300°C
Endurance (P70, 70°C, 1000 Hrs.)	$\Delta R \leq \pm 2\%R$
Damp heat, steady state (40°C, 93% r.h., 56d)	$\Delta R \leq \pm 2\%R$
Climatic sequence	$\Delta R \leq \pm 0.5\%R$
Terminal strength	None
Terminal tensile strength	None
Resistance to soldering heat (350°C, 3.5s)	$\Delta R \leq \pm 0.5\%R$ typ.
Solderability (Solder bath method 235±5°C, 2±0.5s)	Good tinning (≥ 90 % covered), no visible damage

## ▶ How to Order

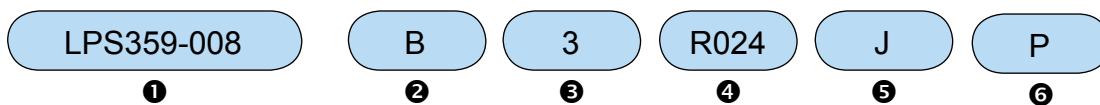

① Part Number: LPS359-008, LPS359-009, LPS359-010, LPS359-011

② Terminal Type

Code	Resistance Value (Ω)
A	4 Terminals
B	2 Terminals

② Rated power

Code	Rated power
1	1 Watt
2	2 Watt
3	3 Watt
5	5 Watt

⑤ Resistance Value (Ω)

Code	Resistance Value (Ω)
R002	0.002Ω
R010	0.010Ω
R022	0.022Ω
R050	0.050Ω

④ Tolerance %

Code	Tolerance %
G	±2%
J	±5%
K	±10%

⑤ Package-Code

Code	Package-Code
P	Bulk

*Back to 1st Page - Low Ohm Current Sensing Resistors (LPS)*

# Low Resistance Power Resistors

## Lowest Ohmic Value Resistor (BWL) Minimise Power Consumption

### ▶ Preview

In response to demand for more energy efficient products, Token Electronics has expanded its current sensing resistors offering with the launch of the BWL series, its lowest ohmic value resistor, to minimise power consumption.

The BWL series has been designed for current sensing in power electronic systems and the resistors are available in 0.5W to 10W power ratings, with a wide ohmic range starting from as low as 0.005Ω.

Products in the economical, low-inductance BWL series are axial leads with high temperature mold compound, making them well-suited to the industry trend and are ideal for all types of current sensing applications including switching and linear power supplies, instruments and power amplifiers

In addition, the BWL series utilizes metal strip technology, essential for those involved in constructing devices and circuits for the detection of currents.

Token's BWL standard series is lead-free and RoHS compliant and can be a replacement for Vishay, IRC, KAO, Panasonic current sense devices with more competitive price and short lead time. Contact us with your specific needs.



### ▶ Material

- Terminals: Tinned copper.
- Element: Self-supporting nickel-chrome alloy.
- BWL metal strip technology utilizes manganin.
- Encapsulation: High temperature mold compound.

### ▶ Applications

- Switching and linear power supplies.
- Notebook power management.
- Power amplifiers.
- Instruments.

### ▶ Features

- Low inductance.
- Excellent load life stability.
- Low temperature coefficient.
- Cooler operation for high power to size ratio.
- Proprietary processing technique produces extremely low resistance values.

## Technical Specifications & Dimensions

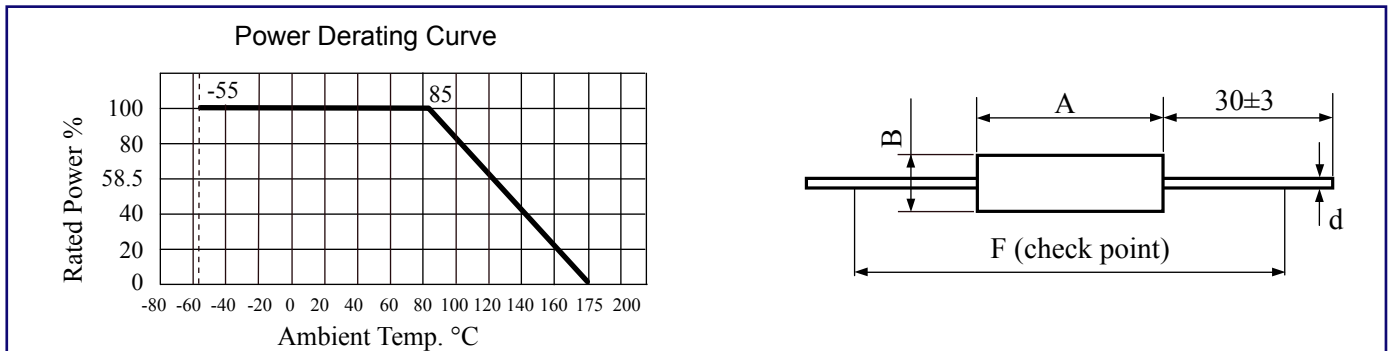

Type	Rated Watts at 25°C (W)	Resistance Range (Ω)		Tolerance	Dimensions (mm)			
		Min	Max		A±0.25	ΦB±0.25	Φd	F
BWL-0.5	0.5	0.01	1	±1% ±2% ±5%	7.0	3.0	0.8	27.0
BWL-1	1.0	0.005	2		11.0	3.0	0.8	31.0
BWL-3	3.0	0.005	2		15.0	5.2	0.8	34.0
BWL-4	4.0	0.005	5		18.0	6.5	0.8	38.0
BWL-5	5.0	0.005	1		24.0	8.4	1.0	44.0
BWL-10	10.0	0.01	1		46.5	10.0	1.0	66.0

## Electrical Performance

Test Items	Test Conditions	Specifications
Operating Temp. Range		-55°C ~ 175°C
Insulation Resistance	500V	>1GΩ
Dielectric Withstanding Voltage	500V AC 1 Min.	ΔR ≤ ±0.1%R
Load Life	70°C on~off cycle 1000 Hrs.	ΔR ≤ ±1%R
Moisture-Proof Load Life	40°C 95% RH on~off cycle 21 Hrs.	ΔR ≤ ±0.2%R
Resistance to soldering heat	350°C, 3.5s	ΔR ≤ ±0.1%R
Solderability	235±5°C, 5s(solder bath method)	IEC68-2-20(1968)

## How to Order

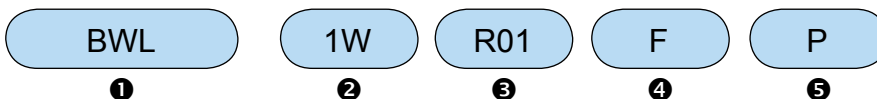

❶ Part Number

❷ Power Rating (W)

❸ Resistance

Code	Resistance
R01	0.01Ω
R1	0.1Ω
1R	1Ω

❹ Resistance Tolerance

Code	Resistance Tolerance
F	±1%
G	±2%
J	±5%

❺ Packaging: P (Bulk)

*Back to 1st Page - Power Low Resistance Resistors (BWR)*

# Metal Film Extra Low Ohmic Precision Resistors

## Token Advanced Film NE Spell High Precision

### ▶ Preview

A homogenous film of metal alloy is deposited on a high grade ceramic body. After a helical groove has been cut in the resistive layer, tinned connecting wires of electrolytic copper are welded to the end-caps.

The resistors are moulding which provides electrical, mechanical, and climatic protection.

Token has complete capability to develop specific reliability programs designed to customer requirements. Products equate Vishay, Ohmite, Caddock, IRC, EBG, Panasonic Precision Devices with more competitive price and fast delivery.

Full line products meet RoHS compliant. Detailed specifications, both mechanical and electrical, please contact our sales representative for more information.

### MIL-PRF-55182 :

The NE series meets the electrical, environmental and dimensional requirements of MIL-PRF-55182. Referencing to Chinese National Quality Standard GJB244A-2001.

### POWER RATING

Power ratings are based on the following two conditions,

- $\pm 2.0\%$  maximum  $\Delta R$  in 10 000 h load life.
- $+ 175\text{ }^\circ\text{C}$  maximum operating temperature.

### Applications

- Telecom
- Test and measurement
- Space and aircraft electronics
- Industrial process control systems
- Measuring and calibration equipment

### Features

- Metal film moulding type
- Industrial grades, RoHS Compliant.
- Excellent stability and High reliability.
- Caps range of ultra low resistance  $0.05\Omega \sim 10\Omega$ .
- Extreme precision tolerance tight to A5( $\pm 0.05\%$ ).
- Extensive stocking program at distributors and factory.
- Controlled temperature coefficient and narrowed to C7 ( $\pm 5\text{PPM}/^\circ\text{C}$ ).
- Token NE Series meets MIL-PRF-55182 and GJB244A-2001 quality standards.



## ► Dimensions & Technical Characteristics

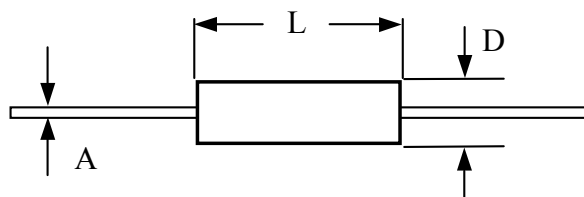

Metal Film (NE) Dimensions

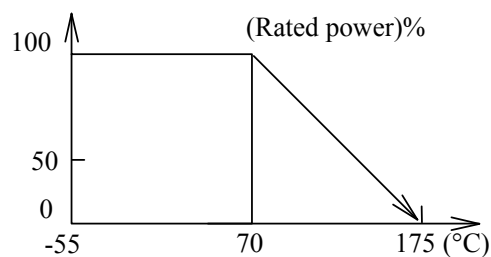

Precision Resistor (NE) Power Derating Curve

Type		NE1/10	NE1/8	NE1/4	NE1/2
Rated Wattage (W)	70 °C	0.25	0.5	0.75	1.0
	125 °C	0.10	0.125	0.25	0.5
Resistance Range ( $\Omega$ )		0.05 ~ 10	0.05 ~ 10	0.025 ~ 10	0.025 ~ 10
Dimensions (mm)	$L \pm 0.3$	6.80	10.2	14.5	18.4
	$D \pm 0.4$	2.50	3.80	4.50	6.50
	$A \pm 0.05$	0.60	0.60	0.60	0.80
Working Temperature Range		-55°C ~ +175°C			
Nominal Resistance Tolerance J( $\pm 5.0\%$ ) F( $\pm 1.0\%$ ) D( $\pm 0.5\%$ ) C( $\pm 0.25\%$ ) B( $\pm 0.10\%$ ) A5( $\pm 0.05\%$ )		all resistance:J 0.1 $\Omega$ ≤R≤0.2 $\Omega$ :J / F 0.2 $\Omega$ <R≤0.4 $\Omega$ :J / F / D 0.4 $\Omega$ <R≤1.0 $\Omega$ :J / F / D / C 1 $\Omega$ <R≤5 $\Omega$ :J / F / D / C / B 5 $\Omega$ <R : J / F / D / C / B / A5			
Temperature Coefficient PPM Normal test range (+25°C ~ +85°C)		1 $\Omega$ ≤R<3 $\Omega$ : C2( $\pm 50$ PPM/°C), C3( $\pm 25$ PPM/°C) R>3 $\Omega$ : C2( $\pm 50$ PPM/°C), C3( $\pm 25$ PPM/°C),C5( $\pm 15$ PPM/°C), C6( $\pm 10$ PPM/°C), C7( $\pm 5$ PPM/°C) R<1 $\Omega$ :No Temperature Coefficient reference			

**Remark:** Please contact Token's Representatives if your requirement is not in above range.

## Periodical Inspection Items and Methods

Type	Item	Method	Requirement
Long Period	Life time	GJB244A (MIL-PRF-55182) 4.8.18 Rated Wattage, 125°C, 2000h 10000h	GJB244A (MIL-PRF-55182) 3.24 $\Delta R \leq \pm(0.5\%R + 0.01\Omega)$ $\Delta R \leq \pm(2\%R + 0.01\Omega)$
	Humidity	GJB244A (MIL-PRF-55182) 4.8.18 -10°C ~ +65°C, RH < 90% Rated Wattage, Cycle 240h.	GJB244A (MIL-PRF-55182) 3.21 $\Delta R \leq \pm(0.4\%R + 0.01\Omega)$
	High temp exposed	GJB244A 4.8.19 175°C 2000h	GJB244A (MIL-PRF-55182) 3.25 $\Delta R \leq \pm(2.0\%R + 0.01\Omega)$
Short Period	Dielectric voltage	GJB244A (MIL-PRF-55182) 4.8.12/4.8.23/4.8.10	GJB244A (MIL-PRF-55182) 3.18/3.29/3.16 $\Delta R \leq \pm(0.15\%R + 0.01\Omega)$ no physical damage, arc, isolation break through
	Lead strength Impact High frequency vibration	GJB244A (MIL-PRF-55182) 4.8.11/4.8.16/4.8.17	GJB244A (MIL-PRF-55182) 3.17/3.22/3.23 $\Delta R \leq \pm(0.20\%R + 0.01\Omega)$ no physical damage
	Solderability	GJB244A (MIL-PRF-55182) 4.8.14	GJB244A (MIL-PRF-55182) 3.20 $\Delta R \leq \pm(0.10\%R + 0.01\Omega)$ no physical damage

## How to Order

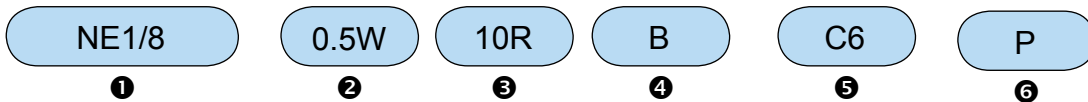

① Part Number: NE1/10, NE1/8, NE1/4, NE1/2

② Rated Power (W)

Code	Temperature	Rated Power (W)
NE1/10	70 °C	0.25
NE1/8		0.50
NE1/4		0.75
NE1/2		1.00
NE1/10	125°C	0.10
EE1/8		0.125
EE1/4		0.25
EE1/2		0.50

③ Resistance Value

Code	Resistance Value
R01	0.01Ω
R1	0.1Ω
1R	1Ω

④ Resistance Tolerance

Code	Resistance Tolerance
A5	±0.05%
B	±0.10%
C	±0.25%
D	±0.50%
F	±1.00%
J	±5.00%

④ Temperature coefficient (PPM/°C)

Code	Temperature coefficient
C2	±50ppm/°C
C3	±25ppm/°C
C5	±15ppm/°C
C6	±10ppm/°C
C7	±5ppm/°C

⑥ Packaging: P (Bulk)

*Back to 1st Page - Metal Film Precision Resistors (NE)*