

FEATURES

- Advanced trench process technology
- avalanche energy, 100% test
- Fully characterized avalanche voltage and current
- Lead free product

ID =200A
BV=100V
R_{DS(ON)}=4.7mΩ (Typ.)

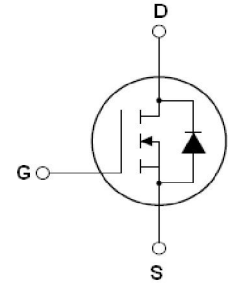

DESCRIPTION

The SSF1006A is a new generation of high voltage and low current N-Channel enhancement mode trench power MOSFET. This new technology increases the device reliability and electrical parameter repeatability. SSF1006A is assembled in high reliability and qualified assembly house.

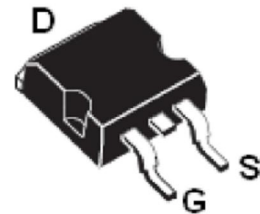

SSF1006A Top View (D2PAK)

APPLICATIONS

- Power switching application

Absolute Maximum Ratings

	Parameter	Max.	Units
$I_D@T_c=25^\circ\text{C}$	Continuous drain current, $V_{GS}@10\text{V}$	200	A
$I_D@T_c=100^\circ\text{C}$	Continuous drain current, $V_{GS}@10\text{V}$	130	
I_{DM}	Pulsed drain current ①	800	
$P_D@T_c=25^\circ\text{C}$	Power dissipation	272	W
	Linear derating factor	1.5	W/C
V_{GS}	Gate-to-Source voltage	± 20	V
E_{AS}	Single pulse avalanche energy ②	960	mJ
E_{AR}	Repetitive avalanche energy	TBD	mJ
dv/dt	Peak diode recovery voltage	31	v/ns
T_J T_{STG}	Operating Junction and Storage Temperature Range	-55 to +150	$^\circ\text{C}$

Thermal Resistance

	Parameter	Min.	Typ.	Max.	Units
$R_{\theta JC}$	Junction-to-case	—	0.46	—	$^\circ\text{C/W}$
$R_{\theta JA}$	Junction-to-ambient	—	—	62	

Electrical Characteristics @ $T_J=25^\circ\text{C}$ (unless otherwise specified)

	Parameter	Min.	Typ.	Max.	Units	Test Conditions
BV_{DSS}	Drain-to-Source breakdown voltage	100	—	—	V	$V_{GS}=0\text{V}, I_D=250\mu\text{A}$
$R_{DS(on)}$	Static Drain-to-Source on-resistance	—	4.7	5.5	mΩ	$V_{GS}=10\text{V}, I_D=30\text{A}$
$V_{GS(th)}$	Gate threshold voltage	2.0	—	4.0	V	$V_{DS}=V_{GS}, I_D=250\mu\text{A}$
I_{DSS}	Drain-to-Source leakage current	—	—	2	μA	$V_{DS}=100\text{V}, V_{GS}=0\text{V}$

		—	—	10		$V_{DS}=100V,$ $V_{GS}=0V, T_J=150C$
I_{GSS}	Gate-to-Source forward leakage	—	—	100	nA	$V_{GS}=20V$
	Gate-to-Source reverse leakage	—	—	-100		$V_{GS}=-20V$
Q_g	Total gate charge	—	108		nC	$I_D=30A, V_{GS}=10V$ $V_{DD}=30V$
Q_{gs}	Gate-to-Source charge	—	24	—		
Q_{gd}	Gate-to-Drain("Miller") charge	—	37	—		
$t_{d(on)}$	Turn-on delay time	—	18.2		nS	$V_{DD}=30V$ $I_D=2A, R_L=15\Omega$ $R_G=2.5\Omega$ $V_{GS}=10V$
t_r	Rise time	—	15.6			
$t_{d(off)}$	Turn-Off delay time	—	70.5			
t_f	Fall time	—	13.8			
C_{iss}	Input capacitance	—	3150		pF	$V_{GS}=0V$ $V_{DS}=25V$ $f=1.0MHZ$
C_{oss}	Output capacitance	—	350			
C_{rss}	Reverse transfer capacitance	—	240			

Source-Drain Ratings and Characteristics

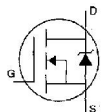
	Parameter	Min.	Typ.	Max.	Units	Test Conditions
I_S	Continuous Source Current (Body Diode)	—	—	160	A	MOSFET symbol showing the integral reverse p-n junction diode. 
I_{SM}	Pulsed Source Current (Body Diode) ①	—	—	520		
V_{SD}	Diode Forward Voltage	—	—	1.3	V	$T_J=25C, I_S=60A, V_{GS}=0V$ ③
t_{rr}	Reverse Recovery Time	—	57	—	nS	$T_J=25C, I_F=75A$ $di/dt=100A/\mu s$ ③
Q_{rr}	Reverse Recovery Charge	—	107	—	μC	
t_{on}	Forward Turn-on Time	Intrinsic turn-on time is negligible (turn-on is dominated by $L_s + L_D$)				

Notes:

- ① Repetitive rating; pulse width limited by max junction temperature.
- ② Test condition: $L = 0.3mH, V_{DD} = 50V, I_D=80A$
- ③ Pulse width $\leq 300\mu s$, duty cycle $\leq 1.5\%$; $R_G = 25\Omega$ Starting $T_J = 25^\circ C$

EAS Test Circuit

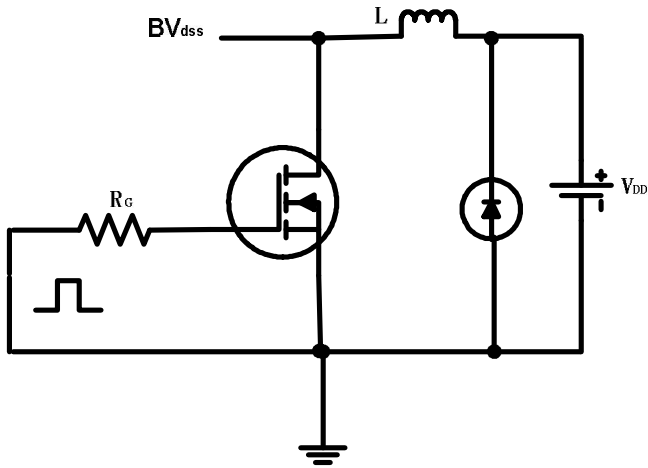

Gate Charge Test Circuit

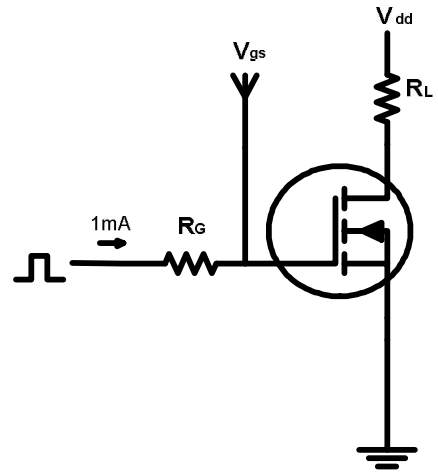

Switch Time Test Circuit

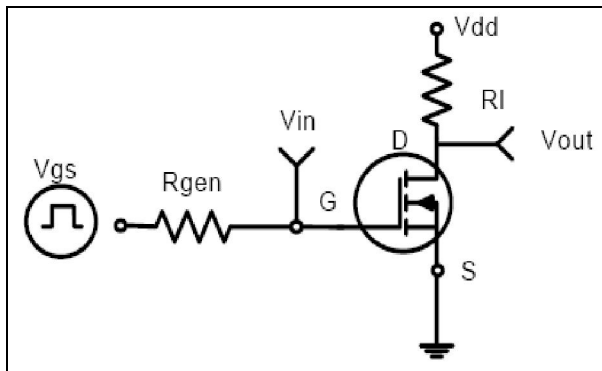

Switch Waveform

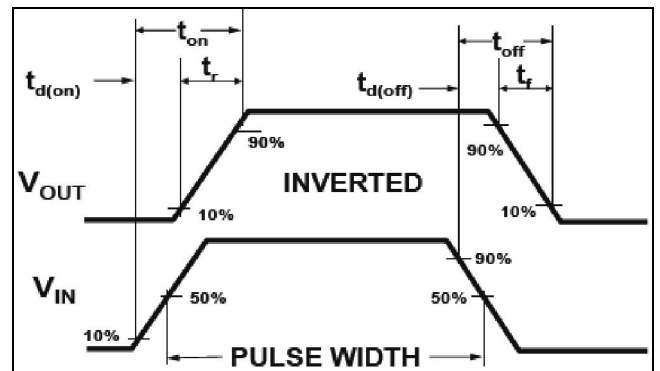

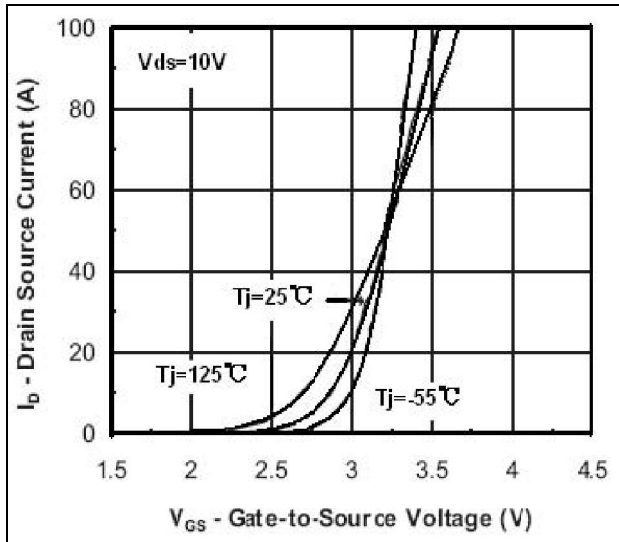

Transfer Characteristic

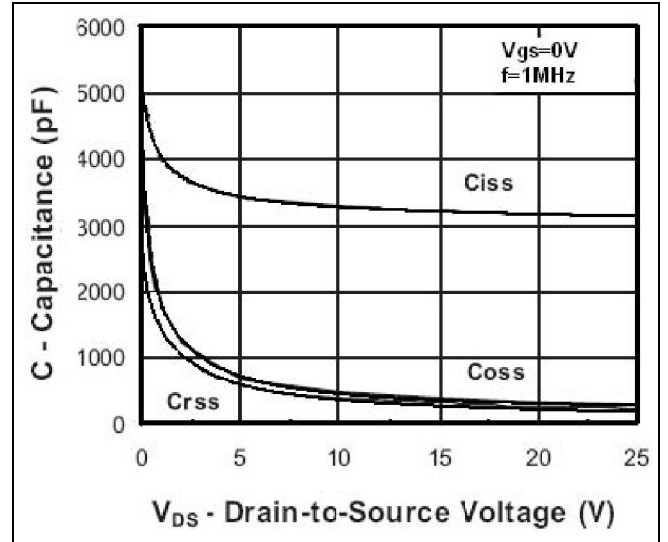

Capacitance

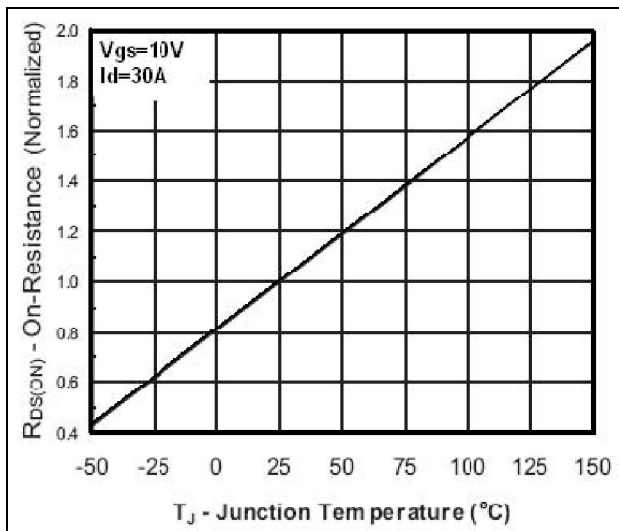

On Resistance vs. Junction Temperature

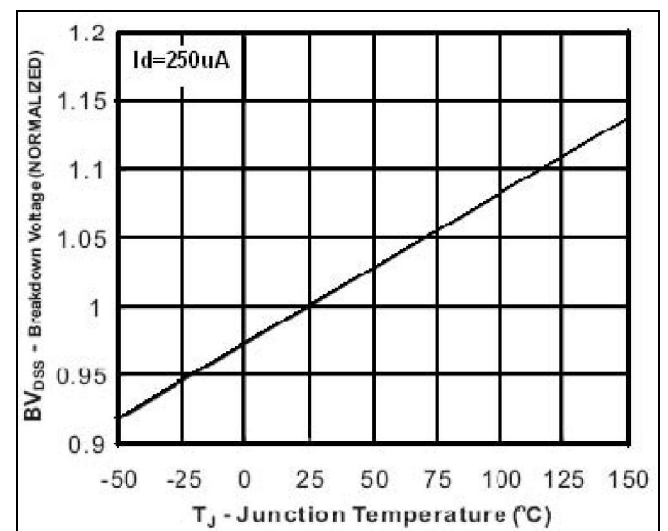

Breakdown Voltage vs. Junction Temperature

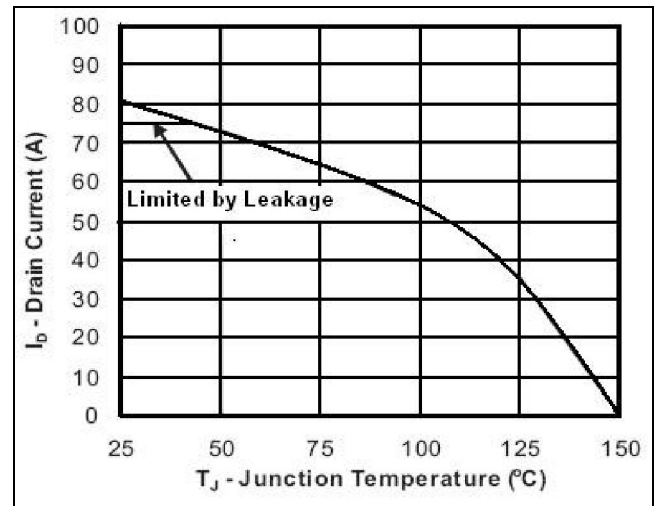
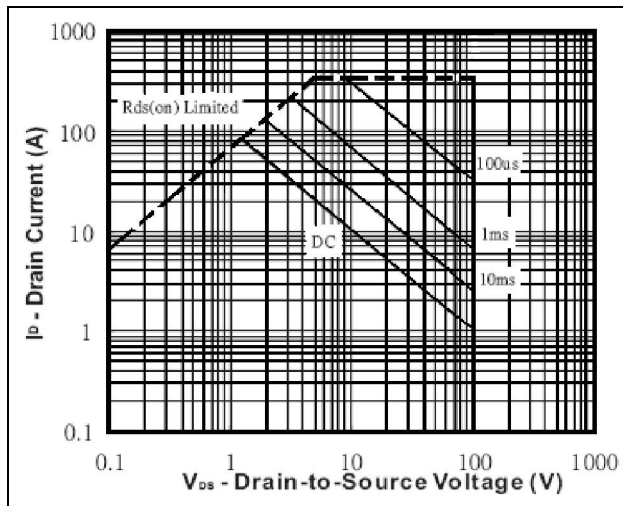
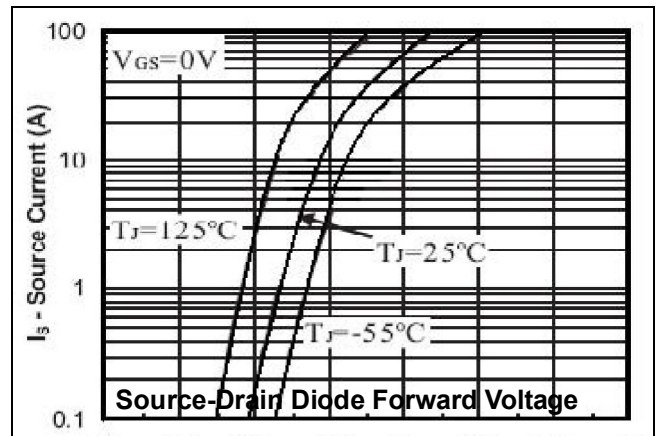
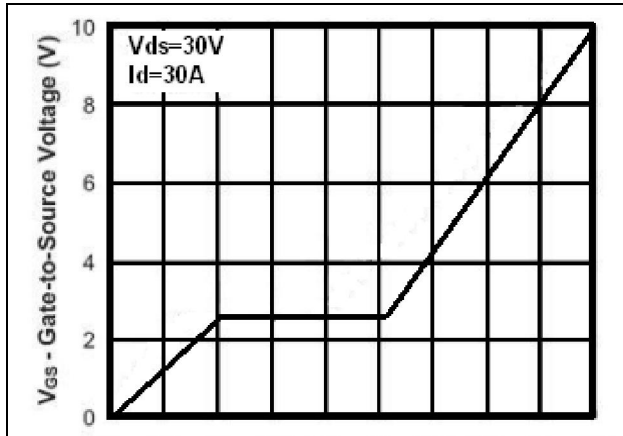

Safe Operation Area

Max Drain Current vs. Junction

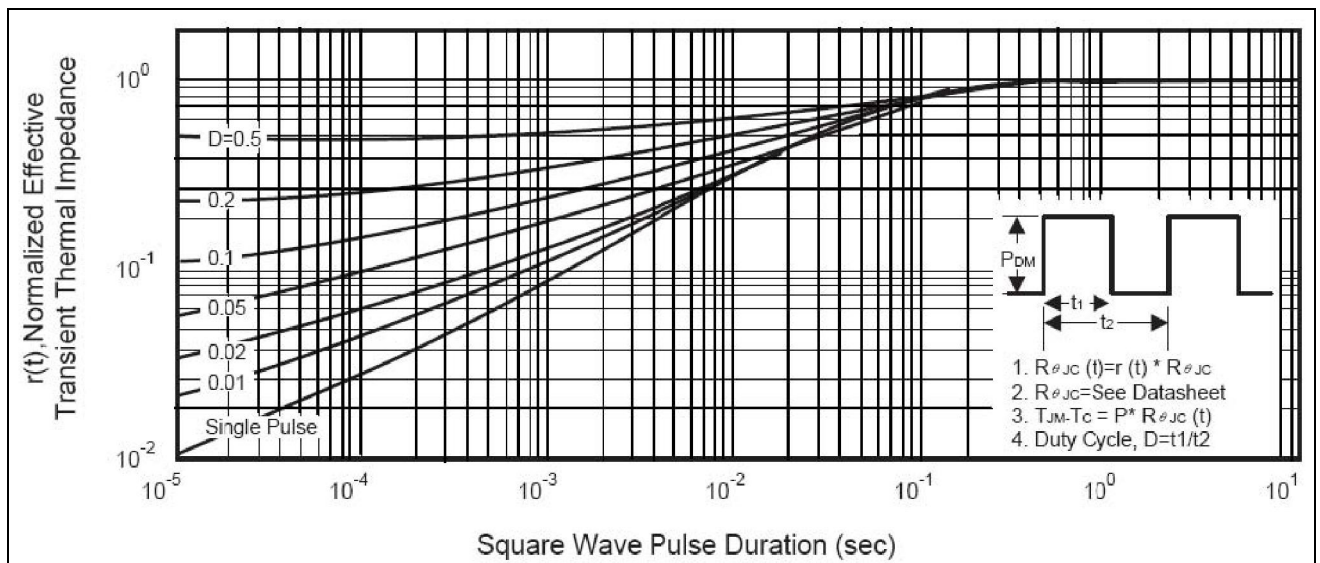

Transient Thermal Impedance Curve

D2PAK MECHANICAL DATA

DIM.	mm.			inch		
	MIN.	TYP	MAX.	MIN.	TYP.	MAX.
A	4.4		4.6	0.173		0.181
A1	2.49		2.69	0.098		0.106
A2	0.03		0.23	0.001		0.009
B	0.7		0.93	0.027		0.036
B2	1.14		1.7	0.044		0.067
C	0.45		0.6	0.017		0.023
C2	1.23		1.36	0.048		0.053
D	8.95		9.35	0.352		0.368
D1		8			0.315	
E	10		10.4	0.393		
E1		8.5			0.334	
G	4.88		5.28	0.192		0.208
L	15		15.85	0.590		0.625
L2	1.27		1.4	0.050		0.055
L3	1.4		1.75	0.055		0.068
M	2.4		3.2	0.094		0.126
R		0.4			0.015	
V2	0°		4°			

