

PROXIMITY/UV/AMBIENT LIGHT SENSOR MODULE WITH I²C INTERFACE

Features

- Integrated infrared proximity detector
 - Proximity detection adjustable from under 1 cm to over 50 cm
 - Three independent LED drivers
 - 15 current settings from 5.6 mA to 360 mA for each LED driver
 - 25.6 μ s LED driver pulse width
 - 50 cm proximity range with single pulse (<3 klx)
 - 15 cm proximity range with single pulse (>3 klx)
 - Operates at up to 128 klx (direct sunlight)
 - High reflectance sensitivity < 1 μ W/cm²
 - High EMI immunity without shielded packaging
- Integrated UV index sensor
- Integrated ambient light sensor
 - 100 mlx resolution possible, allowing operation under dark glass
 - 1 to 128 klx dynamic range possible across two ADC range settings
- Accurate lux measurements with IR correction algorithm
- Industry's lowest power consumption
 - 1.71 to 3.6 V supply voltage
 - 9 μ A average current (LED pulsed 25.6 μ s every 800 ms at 180 mA plus 3 μ A Si1145/46/47-M01 supply)
 - < 500 nA standby current
 - Internal and external wake support
 - Built-in voltage supply monitor and power-on reset controller
 - 25.6 μ s LED "on" time keeps total power consumption duty cycle low without compromising performance or noise immunity
- IR LED integrated inside the module
- I²C Serial communications
 - Up to 3.4 Mbps data rate
 - Slave mode hardware address decoding (0x60)
- Small-outline 10-lead 4.9x2.85x1.2 mm QFN
- Temperature Range
 - -40 to +85 °C

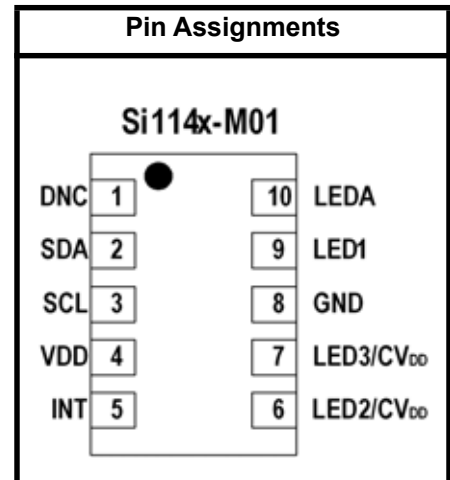

Applications

- Handsets
- Heart rate monitoring
- Pulse oximetry
- Wearables
- E-book readers
- Notebooks/Netbooks
- Portable consumer electronics
- Touchless switches
- Touchless sliders
- Consumer electronics
- Display backlighting control

Description

The Si1145/46/47-M01 is a low-power, reflectance-based, proximity, UV Index and ambient light module with integrated single IR LED, two additional LED driver outputs, I²C digital interface, and programmable-event interrupt output. This touchless sensor module includes an analog-to-digital converter, integrated high-sensitivity visible and infrared photodiodes, digital signal processor, and three integrated infrared LED drivers with fifteen selectable drive levels. The Si1145/46/47-M01 offers excellent performance under a wide dynamic range and a variety of light sources including direct sunlight. The Si1145/46/47-M01 can also work under dark glass covers. The photodiode response and associated digital conversion circuitry provide excellent immunity to artificial light flicker noise and natural light flutter noise. With two or more LEDs, the Si1145/46/47-M01 is capable of supporting multiple-axis proximity motion detection. The Si1145/46/47-M01 devices are provided in a 10-lead 4.9x2.85x1.2 mm QFN package and are capable of operation from 1.71 to 3.6 V over the -40 to +85 °C temperature range.

Si1145/46/47-M01

Functional Block Diagram

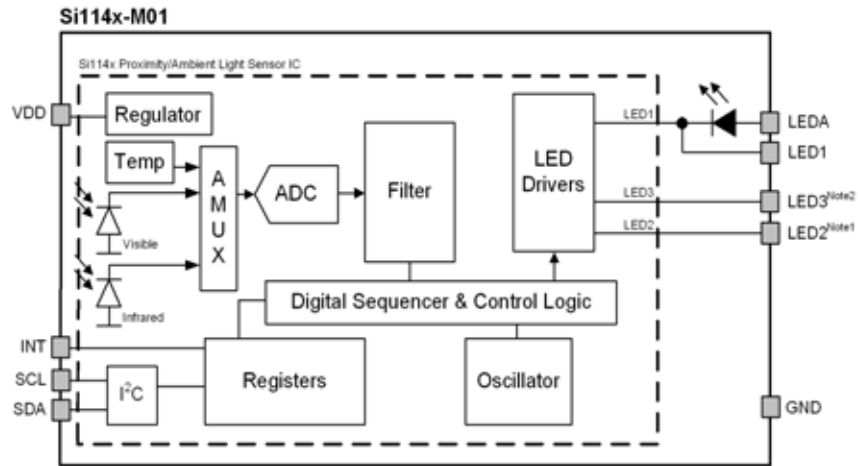

Notes:

1. Si1146-M01 and Si1147-M01 only. Must be tied to V_{DD} with Si1145-M01.
2. Si1147-M01 only. Must be tied to V_{DD} with Si1145-M01 and Si1146-M01.

Figure 1. Si114x-M01 Sensor Module

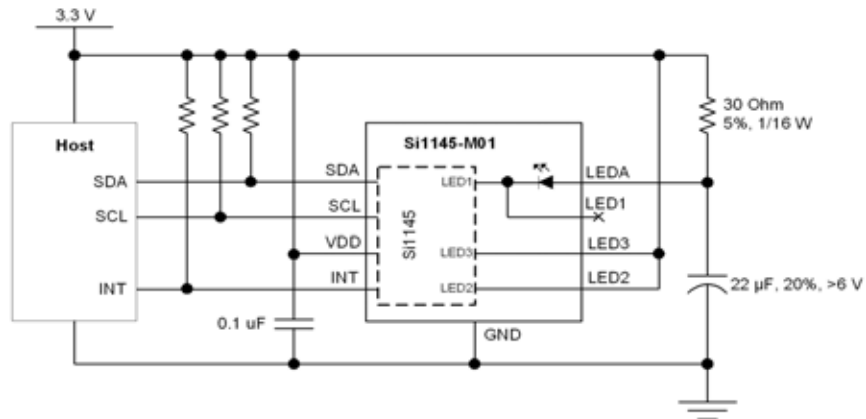

Figure 2. Si1145-M01 Module Basic Application Schematic for 1 LED

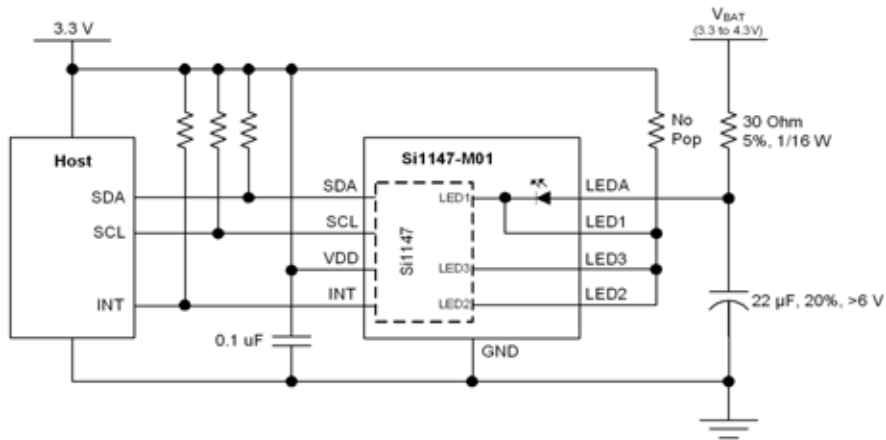

Figure 3. Si1147-M01 Module Application Schematic for Long-Range Proximity Detection

Note: For more application examples, refer to “AN498: Si114x Designer’s Guide”.

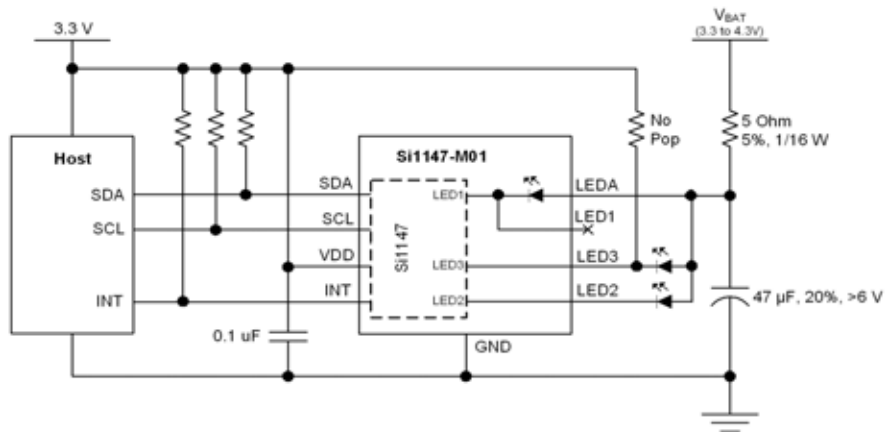

Figure 4. Si1147-M01 Module Application Schematic with Three LEDs and Separate LED Power Supply

TABLE OF CONTENTS

<u>Section</u>	<u>Page</u>
1. Electrical Specifications	5
1.1. Performance Tables	5
1.2. Typical Performance Graphs	12
2. Functional Description	15
2.1. Introduction	15
2.2. Proximity Sensing (PS)	15
2.3. Ambient Light	16
2.4. Ultraviolet (UV) Index	18
2.5. Host Interface	20
3. Operational Modes	22
3.1. Off Mode	22
3.2. Initialization Mode	22
3.3. Standby Mode	22
3.4. Forced Conversion Mode	23
3.5. Autonomous Operation Mode	23
4. Programming Guide	24
4.1. Command and Response Structure	24
4.2. Command Protocol	25
4.3. Resource Summary	28
4.4. Signal Path Software Model	32
4.5. I2C Registers	33
4.6. Parameter RAM	48
5. Pin Descriptions	62
6. Ordering Guide	63
7. Package Outline: 10-Pin QFN	64
8. Suggested PCB Land Pattern	66
9. Top Markings	67
9.1. Si1145-M01-GMR Top Marking	67
9.2. Si1146-M01-GMR Top Marking	67
9.3. Si1147-M01-GMR Top Marking	67
9.4. Top Marking Explanation	68
Document Change List	69
Contact Information	70

1. Electrical Specifications

1.1. Performance Tables

Table 1. Recommended Operating Conditions

Parameter	Symbol	Test Condition	Min	Typ	Max	Unit
V _{DD} Supply Voltage	V _{DD}		1.71	—	3.6	V
V _{DD} OFF Supply Voltage	V _{DD_OFF}	OFF mode	-0.3		1.0	V
V _{DD} Supply Ripple Voltage		V _{DD} = 3.3 V 1 kHz–10 MHz	—	—	50	mVpp
Operating Temperature	T		-40	25	85	°C
SCL, SDA, Input High Logic Voltage	I ² C _{VIH}		V _{DD} ×0.7	—	V _{DD}	V
SCL, SDA Input Low Logic Voltage	I ² C _{VIL}		0	—	V _{DD} ×0.3	V
PS Operation under Direct Sunlight	Edc		—	—	128	klx
IrLED Emission Wavelength	λ		750	850	950	nm
IrLED Supply Voltage	V _{LED}	IrLED V _F = 1.0 V nominal	V _{DD}	—	4.3	V
IrLED Supply Ripple Voltage		Applies if IrLEDs use separate supply rail 0–30 kHz 30 kHz–100 MHz	— —	— —	250 100	mVpp mVpp
Start-Up Time		V _{DD} above 1.71 V	25	—	—	ms
LED3 Voltage		Start-up	V _{DD} ×0.77	—	—	V

Table 2. Performance Characteristics¹

Parameter	Symbol	Test Condition	Min	Typ	Max	Unit
I _{DD} OFF Mode	I _{off}	V _{DD} < V _{DD_OFF} (leakage from SCL, SDA, and INT not included)	—	240	1000	nA
I _{DD} Standby Mode	I _{sb}	No ALS / PS Conversions No I ² C Activity V _{DD} = 1.8 V	—	150	500	nA
I _{DD} Standby Mode	I _{sb}	No ALS / PS Conversions No I ² C Activity V _{DD} = 3.3 V	—	1.4	—	μA
I _{DD} Actively Measuring	I _{active}	Without LED influence, V _{DD} = 3.3 V	—	4.3	5.5	mA
Peak I _{DD} while LED1, LED2, or LED3 is Actively Driven		V _{DD} = 3.3 V	—	8	—	mA
LED Driver Saturation Voltage ^{2,3}		V _{DD} = 1.71 to 3.6 V PS_LEDn = 0001 PS_LEDn = 0010 PS_LEDn = 0011 PS_LEDn = 0100 PS_LEDn = 0101 PS_LEDn = 0110 PS_LEDn = 0111 PS_LEDn = 1000 PS_LEDn = 1010 PS_LEDn = 1010 PS_LEDn = 1011 PS_LEDn = 1100 PS_LEDn = 1101 PS_LEDn = 1110 PS_LEDn = 1111	—	50	70	mV
LED1, LED2, LED3 Pulse Width	t _{PS}		—	25.6	30	μs
LED1, LED2, LED3, INT, SCL, SDA Leakage Current		V _{DD} = 3.3 V	-1	—	1	μA
Notes:						
1. Unless specifically stated in "Conditions", electrical data assumes ambient light levels < 1 klx.						
2. Proximity-detection performance may be degraded, especially when there is high optical crosstalk, if the LED supply and voltage drop allow the driver to saturate and current regulation is lost.						
3. Guaranteed by design and characterization.						
4. Represents the time during which the device is drawing a current equal to I _{active} for power estimation purposes. Assumes default settings.						

Table 2. Performance Characteristics¹ (Continued)

Parameter	Symbol	Test Condition	Min	Typ	Max	Unit
LED1, LED2, LED3 Active Current	I_{LEDx}	$V_{DD} = 3.3$ V, single drive				mA
		$V_{LEDn} = 1$ V, PS_LEDn = 0001	3.5	5.6	7	
		$V_{LEDn} = 1$ V, PS_LEDn = 0010	—	11.2	—	
		$V_{LEDn} = 1$ V, PS_LEDn = 0011	13	22.4	29	
		$V_{LEDn} = 1$ V, PS_LEDn = 0100	—	45	—	
		$V_{LEDn} = 1$ V, PS_LEDn = 0101	—	67	—	
		$V_{LEDn} = 1$ V, PS_LEDn = 0110	—	90	—	
		$V_{LEDn} = 1$ V, PS_LEDn = 0111	—	112	—	
		$V_{LEDn} = 1$ V, PS_LEDn = 1000	—	135	—	
		$V_{LEDn} = 1$ V, PS_LEDn = 1001	—	157	—	
		$V_{LEDn} = 1$ V, PS_LEDn = 1010	—	180	—	
		$V_{LEDn} = 1$ V, PS_LEDn = 1011	—	202	—	
		$V_{LEDn} = 1$ V, PS_LEDn = 1100	—	224	—	
		$V_{LEDn} = 1$ V, PS_LEDn = 1101	—	269	—	
$V_{LEDn} = 1$ V, PS_LEDn = 1110	—	314	—			
$V_{LEDn} = 1$ V, PS_LEDn = 1111	—	359	—			
Actively Measuring Time ⁴		Single PS	—	155	—	μ s
		ALS VIS + ALS IR	—	285	—	μ s
		Two ALS plus three PS	—	660	—	μ s
Visible Photodiode Response		Sunlight ALS_VIS_ADC_GAIN = 0 VIS_RANGE = 0	—	0.282	—	ADC counts/ lux
		2500K incandescent bulb ALS_VIS_ADC_GAIN = 0 VIS_RANGE = 0	—	0.319	—	ADC counts/ lux
		“Cool white” fluorescent ALS_VIS_ADC_GAIN = 0 VIS_RANGE = 0	—	0.146	—	ADC counts/ lux
		Infrared LED (875 nm) ALS_VIS_ADC_GAIN = 0 VIS_RANGE = 0	—	8.277	—	ADC counts. m^2/W

Notes:

1. Unless specifically stated in "Conditions", electrical data assumes ambient light levels < 1 klx.
2. Proximity-detection performance may be degraded, especially when there is high optical crosstalk, if the LED supply and voltage drop allow the driver to saturate and current regulation is lost.
3. Guaranteed by design and characterization.
4. Represents the time during which the device is drawing a current equal to I_{active} for power estimation purposes. Assumes default settings.

Table 2. Performance Characteristics¹ (Continued)

Parameter	Symbol	Test Condition	Min	Typ	Max	Unit
Small Infrared Photodiode Response		Sunlight ALS_IR_ADC_GAIN = 0 IR_RANGE = 0	—	2.44	—	ADC counts/lux
		2500K incandescent bulb ALS_IR_ADC_GAIN = 0 IR_RANGE = 0	—	8.46	—	ADC counts/lux
		“Cool white” fluorescent ALS_IR_ADC_GAIN = 0 IR_RANGE = 0	—	0.71	—	ADC counts/lux
		Infrared LED (875 nm) ALS_IR_ADC_GAIN = 0 IR_RANGE = 0	—	452.38	—	ADC counts.m ² /W
Large Infrared Photodiode Response		Sunlight PS_ADC_GAIN = 0 PS_RANGE = 0 PS_ADC_MODE = 0	—	14.07	—	ADC counts/lux
		2500K incandescent bulb PS_ADC_GAIN = 0 PS_RANGE = 0 PS_ADC_MODE = 0	—	50.47	—	ADC counts/lux
		“Cool white” fluorescent PS_ADC_GAIN = 0 PS_RANGE = 0 PS_ADC_MODE = 0	—	3.97	—	ADC counts/lux
		Infrared LED (875 nm) PS_ADC_GAIN = 0 PS_RANGE = 0 PS_ADC_MODE = 0	—	2734	—	ADC counts.m ² /W
Visible Photodiode Noise		All gain settings	—	7	—	ADC counts RMS
Small Infrared Photodiode Noise		All gain settings	—	1	—	ADC counts RMS

Notes:

1. Unless specifically stated in "Conditions", electrical data assumes ambient light levels < 1 klx.
2. Proximity-detection performance may be degraded, especially when there is high optical crosstalk, if the LED supply and voltage drop allow the driver to saturate and current regulation is lost.
3. Guaranteed by design and characterization.
4. Represents the time during which the device is drawing a current equal to I_{active} for power estimation purposes. Assumes default settings.

Table 2. Performance Characteristics¹ (Continued)

Parameter	Symbol	Test Condition	Min	Typ	Max	Unit
Large Infrared Photodiode Noise		All gain settings	—	10	—	ADC counts RMS
Visible Photodiode Offset Drift		VIS_RANGE = 0 ALS_VIS_ADC_GAIN = 0 ALS_VIS_ADC_GAIN = 1 ALS_VIS_ADC_GAIN = 2 ALS_VIS_ADC_GAIN = 3 ALS_VIS_ADC_GAIN = 4 ALS_VIS_ADC_GAIN = 5 ALS_VIS_ADC_GAIN = 6 ALS_VIS_ADC_GAIN = 7	—	-0.3 -0.11 -0.06 -0.03 -0.01 -0.008 -0.007 -0.008	—	ADC counts/°C
Small Infrared Photodiode Offset Drift		IR_RANGE = 0 IR_GAIN = 0 IR_GAIN = 1 IR_GAIN = 2 IR_GAIN = 3	—	-0.3 -0.06 -0.03 -0.01	—	ADC counts/°C
SCL, SDA, INT Output Low Voltage	V _{OL}	I = 4 mA, V _{DD} > 2.0 V I = 4 mA, V _{DD} < 2.0 V	— —	— —	V _{DD} × 0.2 0.4	V V
Temperature Sensor Offset		25 °C	—	11136	—	ADC counts
Temperature Sensor Gain			—	35	—	ADC counts/°C
Notes:						
<ol style="list-style-type: none"> 1. Unless specifically stated in "Conditions", electrical data assumes ambient light levels < 1 klx. 2. Proximity-detection performance may be degraded, especially when there is high optical crosstalk, if the LED supply and voltage drop allow the driver to saturate and current regulation is lost. 3. Guaranteed by design and characterization. 4. Represents the time during which the device is drawing a current equal to I_{active} for power estimation purposes. Assumes default settings. 						

Si1145/46/47-M01

Table 3. I²C Timing Specifications

Parameter	Symbol	Min	Typ	Max	Unit
Clock Frequency	f _{SCL}	0.09	—	3.4	MHz
Clock Pulse Width Low	t _{LOW}	160	—	—	ns
Clock Pulse Width High	t _{HIGH}	60	—	—	ns
Start Condition Hold Time	t _{HD.STA}	160	—	—	ns
Start Condition Setup Time	t _{SU.STA}	160	—	—	ns
Input Data Setup Time	t _{SU.DAT}	10	—	—	ns
Input Data Hold Time	t _{HD.DAT}	0	—	—	ns
Stop Condition Setup Time	t _{SU.STO}	160	—	—	ns

Table 4. LED Electro-Optical Characteristics*

Parameter	Symbol	Test Condition	Min	Typ	Max	Unit
Forward voltage	V _{f1}	I _f = 10 μA	0.8	—	—	V
	V _{f2}	I _f = 50 mA	—	1.6	1.9	V
Reverse current	I _r	V _r = 10 V	—	—	5.0	μA
Peak wavelength	λ _p	I _f = 50 mA	840	855	870	nm
Spectral half-width	Δλ	I _f = 50 mA	—	30	—	nm
Radiant flux	P _o	I _f = 50 mA	12	—	—	mW
Radiant Intensity	I _e	I _f = 50 mA	17	23	30	mW/sr
Half Angle	φ		—	25	—	Degrees

***Note:** All specifications measured at 25 °C.

Table 5. Absolute Maximum Ratings*

Parameter	Test Condition	Min	Max	Unit
V _{DD} Supply Voltage		-0.3	4	V
Operating Temperature		-40	85	°C
Storage Temperature		-65	85	°C
LED1, LED2, LED3 Voltage	at VDD = 0 V, T _A < 85 °C	-0.5	3.6	V
LEDA Voltage		-0.5	4.3	V
INT, SCL, SDA Voltage	at VDD = 0 V, T _A < 85 °C	-0.5	3.6	V
Maximum Total Current Through LED1, LED2, LED3 and LEDA		—	500	mA
Maximum Total Current Through GND		—	600	mA
Forward DC Current Through LEDA	T _A = 25 °C	—	70	mA
ESD Rating	Human Body Model	—	2	kV
	Machine Model	—	225	V
	Charged-Device Model	—	2	kV

***Note:** Permanent device damage may occur if the absolute maximum ratings are exceeded.

1.2. Typical Performance Graphs

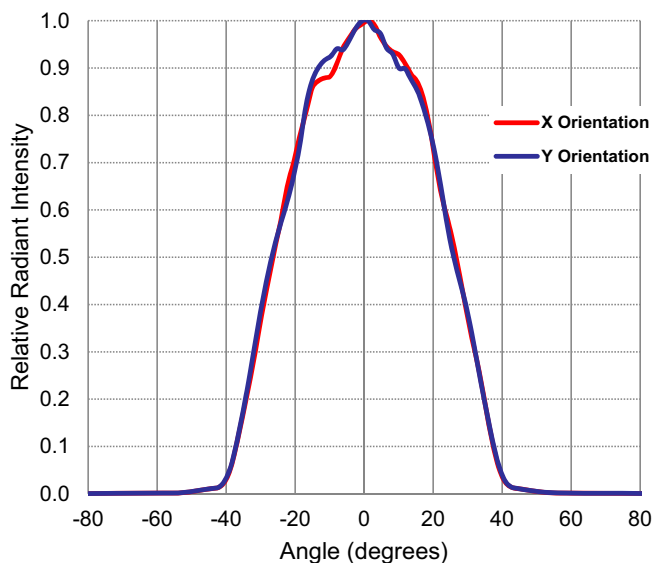

Figure 5. LED Radiant Intensity vs. Angle

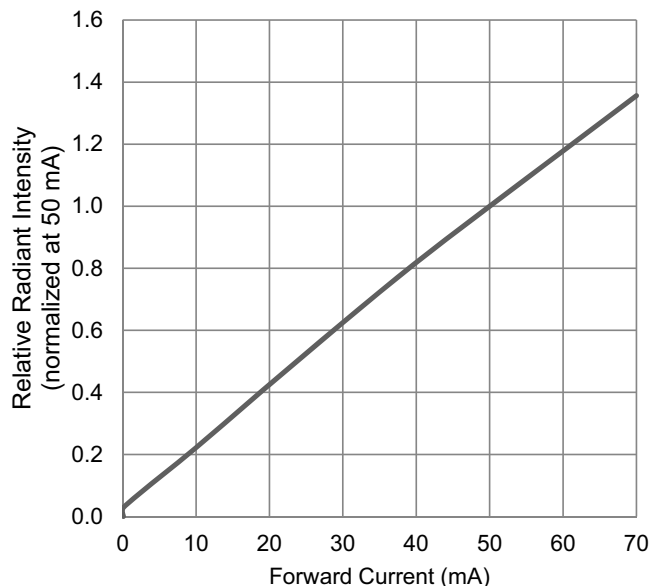

Figure 6. LED Radiant Intensity vs. Forward Current

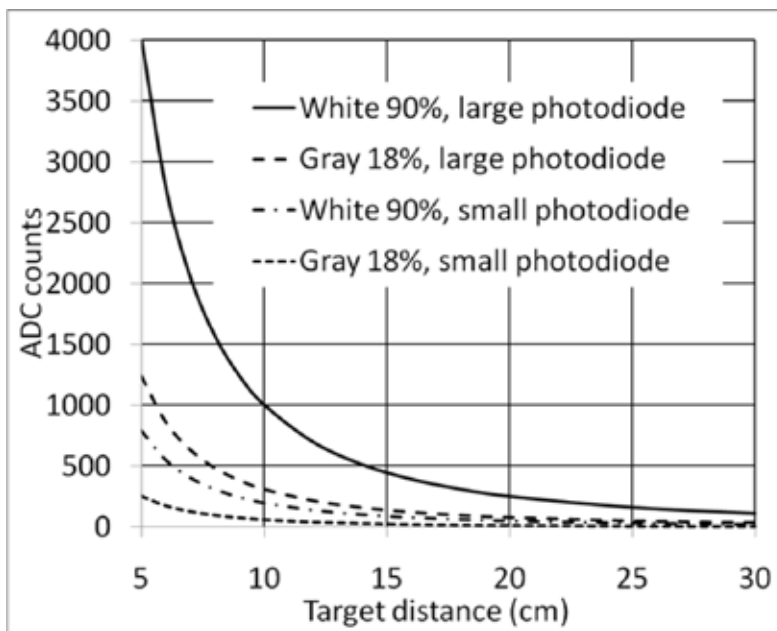

Figure 7. Proximity Response Using Kodak Gray Cards, PS_RANGE = 0, PS_ADC_GAIN = 0 (Single 25.6 μ s LED Pulse), 22.5 mW/sr, No Overlay (Preliminary)

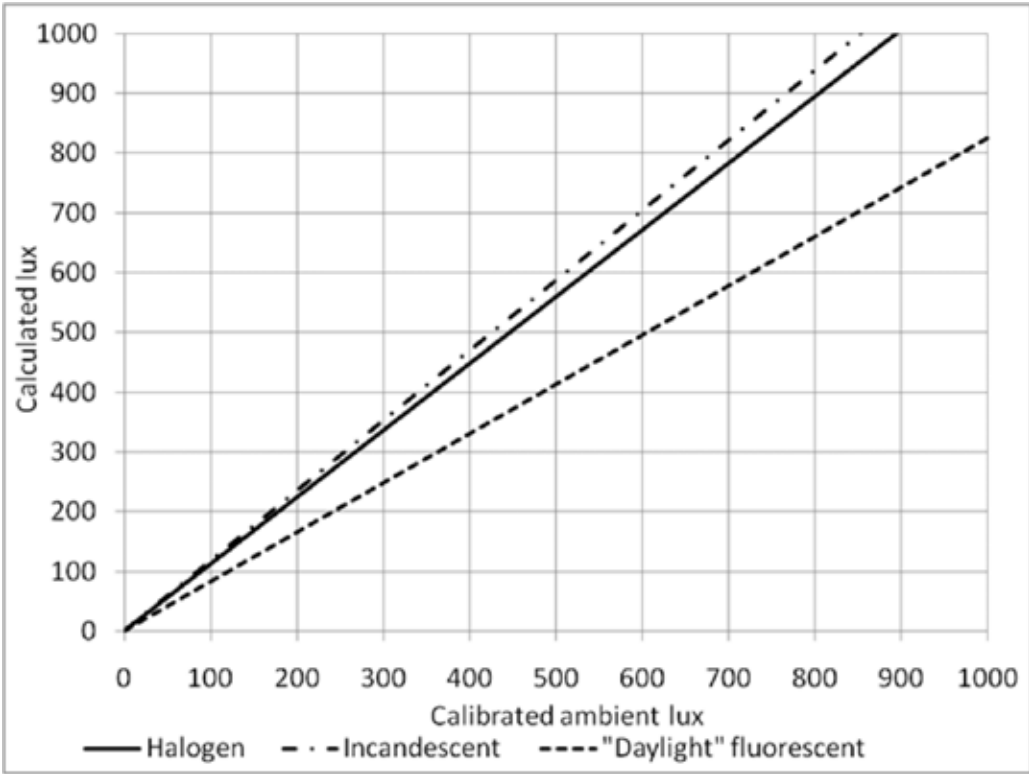

Figure 8. ALS Variability with Different Light Sources

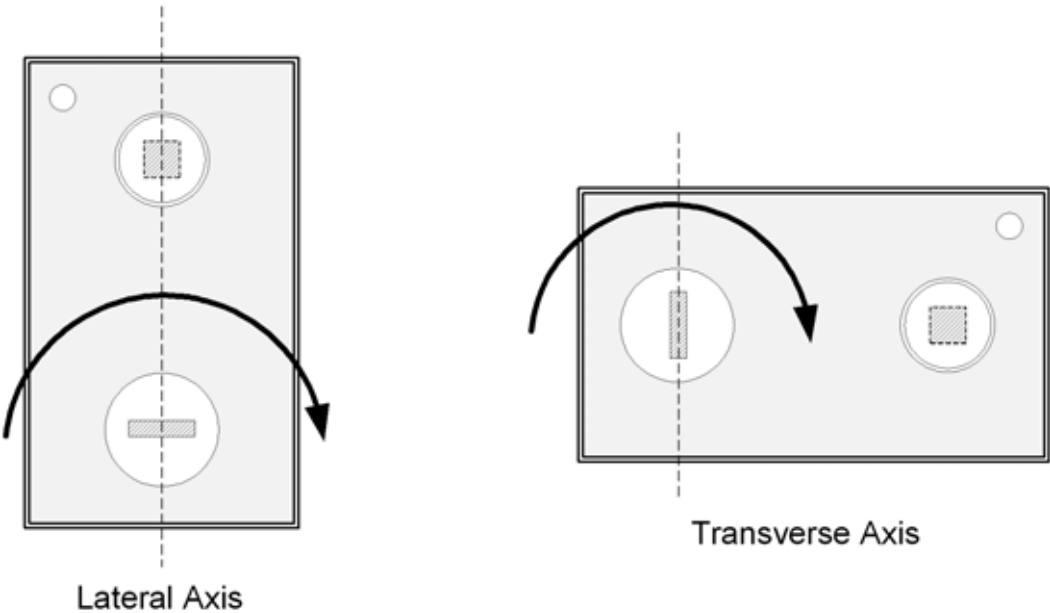

Figure 9. Module Axis Orientation

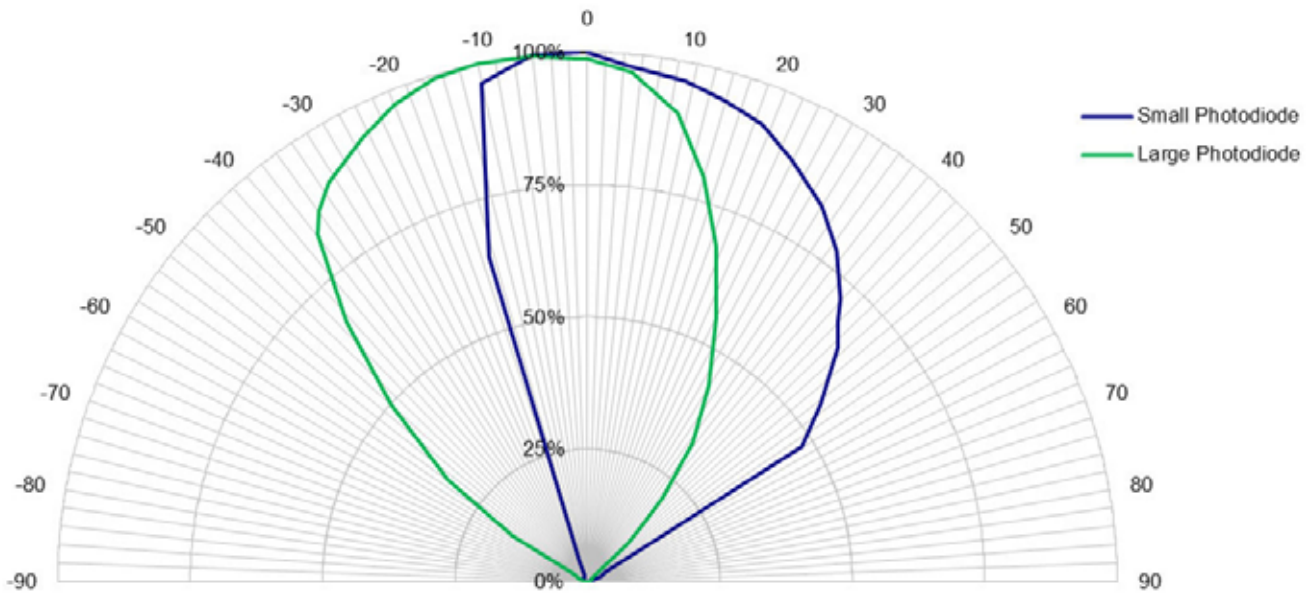

Figure 10. Lateral Photodiode View Angle

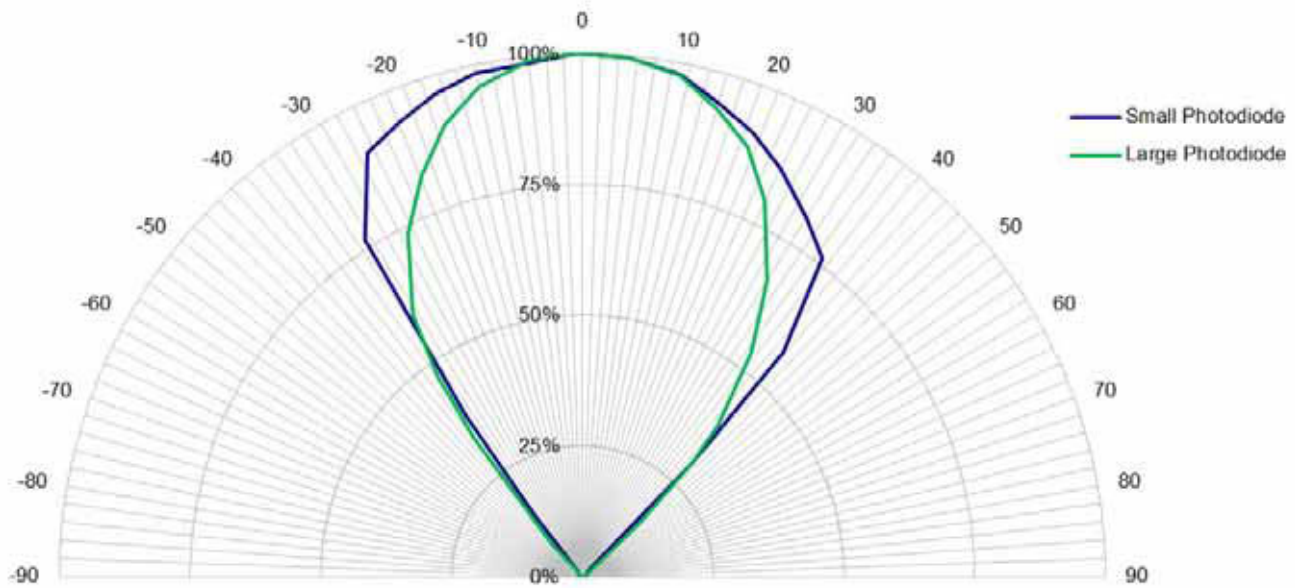

Figure 11. Transverse Photodiode View Angle

2. Functional Description

2.1. Introduction

The Si1145/46/47-M01 is an active optical reflectance proximity detector, UV Index, and ambient light sensor with an integrated infrared LED in a single module. By combining the proximity detector and LED into a single module, the Si1145/46/47-M01 delivers optimized optical performance in a single compact package. Unlike discrete implementations, module-based proximity sensor designs include the necessary optical blocking between the sensor and LED. This reduces “blind spots” that can occur in discrete implementations that lack proper optical blocking.

The Si1145/46/47-M01’s operational state is controlled through registers accessible through the I²C interface. The host can command the Si1145/46/47-M01 to initiate on-demand proximity detection, UV Index, or ambient light sensing. The host can also place the Si1145/46/47-M01 in an autonomous operational state where it performs measurements at set intervals and interrupts the host either after each measurement is completed. This results in an overall system power saving allowing the host controller to operate longer in its sleep state instead of polling the Si1145/46/47-M01. For more details, refer to “AN498: Si114x Designer’s Guide”.

2.2. Proximity Sensing (PS)

The Si1145/46/47-M01 has been optimized for use as either a dual-port or single-port active reflection proximity detector. Over distances of less than 50 cm, the dual-port active reflection proximity detector has significant advantages over single-port, motion-based infrared systems, which are only good for triggered events. Motion-based infrared detectors identify objects within proximity, but only if they are moving. Single-port motion-based infrared systems are ambiguous about stationary objects even if they are within the proximity field. The Si1145/46/47-M01 can reliably detect an object entering or exiting a specified proximity field, even if the object is not moving or is moving very slowly. However, beyond about 30–50 cm, even with good optical isolation, single-port signal processing may be required due to static reflections from nearby objects, such as table tops, walls, etc. If motion detection is acceptable, the Si1145/46/47-M01 can achieve ranges of up to 50 cm, through a single product window.

For small objects, the drop in reflectance is as much as the fourth power of the distance. This means that there is less range ambiguity than with passive motion-based devices. For example, a sixteenfold change in an object’s reflectance means only a fifty-percent drop in detection range.

The Si1145/46/47-M01 contains three LED drivers. For long-range proximity detection, the three LED drivers can be connected in parallel to deliver high drive current for the internal LED. The LED drivers can also be used to drive up to two external LEDs, in addition to the LED integrated within the Si1145/46/47-M01. When the three infrared LEDs are placed in an L-shaped configuration, it is possible to triangulate an object within the three-dimensional proximity field. Thus, a touchless user interface can be implemented with the aid of host software.

The Si1145/46/47-M01 can initiate proximity sense measurements when explicitly commanded by the host or periodically through an autonomous process. Refer to Section “3. Operational Modes” on page 22 for additional details of the Si1145/46/47-M01’s Operational Modes.

Whenever it is time to make a PS measurement, the Si1145/46/47-M01 makes up to three measurements, depending on what is enabled in the CHLIST parameter. Other ADC parameters for these measurements can also be modified to allow proper operation under different ambient light conditions.

The LED choice is programmable for each of these three measurements. By default, each measurement turns on a single LED driver. However, the order of measurements can be easily reversed or even have all LEDs turned on at the same time.

The Si1145/46/47-M01 can also generate an interrupt after a complete set of proximity measurements.

To support different power usage cases dynamically, the LED current of each output is independently programmable. The current can be programmed anywhere from a few to several hundred milliamps. Therefore, the host can optimize for proximity detection performance or for power saving dynamically. This feature can be useful since it allows the host to reduce the LED current once an object has entered a proximity sphere, and the object can still be tracked at a lower current setting. Finally, the flexible current settings make it possible to control the infrared LED currents with a controlled current sink, resulting in higher precision.

The ADC properties are programmable. For indoor operation, the ADC should be configured for low signal range for best reflectance sensitivity. When under high ambient conditions, the ADC should be configured for high signal level range operation.

When operating in the lower signal range, it is possible to saturate the ADC when the ambient light level is high. Any overflow condition is reported in the RESPONSE register, and the corresponding data registers report a value of 0xFFFF. The host can then adjust the ADC sensitivity. Note, however, that the overflow condition is not sticky. If the light levels return to a range within the capabilities of the ADC, the corresponding data registers begin to operate normally. However, the RESPONSE register will continue to hold the overflow condition until a NOP command is received. Even if the RESPONSE register has an overflow condition, commands are still accepted and processed.

Proximity detection ranges beyond 50 cm and up to several meters can be achieved without lensing by selecting a longer integration time. The detection range may be increased further, even with high ambient light, by averaging multiple measurements. Refer to “AN498: Si114x Designer’s Guide” for more details.

2.3. Ambient Light

The Si1145/46/47-M01 has photodiodes capable of measuring both visible and infrared light. However, the visible photodiode is also influenced by infrared light. The measurement of illuminance requires the same spectral response as the human eye. If an accurate lux measurement is desired, the extra IR response of the visible-light photodiode must be compensated. Therefore, to allow the host to make corrections to the infrared light’s influence, the Si1145/46/47-M01 reports the infrared light measurement on a separate channel. The separate visible and IR photodiodes lend themselves to a variety of algorithmic solutions. The host can then take these two measurements and run an algorithm to derive an equivalent lux level as perceived by a human eye. Having the IR correction algorithm running in the host allows for the most flexibility in adjusting for system-dependent variables. For example, if the glass used in the system blocks visible light more than infrared light, the IR correction needs to be adjusted.

If the host is not making any infrared corrections, the infrared measurement can be turned off in the CHLIST parameter.

By default, the measurement parameters are optimized for indoor ambient light levels where it is possible to detect light levels as low as 6 lx. For operation under direct sunlight, the ADC can be programmed to operate in a high signal operation so that it is possible to measure direct sunlight without overflowing the 16-bit result.

For low-light applications, it is possible to increase the ADC integration time. Normally, the integration time is 25.6 μ s. By increasing this integration time to 410 μ s, the ADC can detect light levels as low as 1 lx. The ADC can be programmed with an integration time as high as 3.28 ms, allowing measurement to 100 mlx light levels. The ADC integration time for the Visible Light Ambient measurement can be programmed independently of the ADC integration time of the Infrared Light Ambient measurement. The independent ADC parameters allow operation under glass covers having a higher transmittance to Infrared Light than Visible Light.

When operating in the lower signal range, or when the integration time is increased, it is possible to saturate the ADC when the ambient light suddenly increases. Any overflow condition is reported in the RESPONSE register, and the corresponding data registers report a value of 0xFFFF. Based on either of these two overflow indicators, the host can adjust the ADC sensitivity. However, the overflow condition is not sticky. If the light levels return to a range within the capabilities of the ADC, the corresponding data registers begin to operate normally. The RESPONSE register will continue to hold the overflow condition until a NOP command is received. Even if the RESPONSE register has an overflow condition, commands are still accepted and processed.

The Si1145/46/47-M01 can initiate ALS measurements either when explicitly commanded by the host or periodically through an autonomous process. Refer to "3. Operational Modes" on page 22 for additional details of the Si1145/46/47-M01's Operational Modes. The conversion frequency setting is programmable and independent of the Proximity Sensor. This allows the Proximity Sensor and Ambient Light sensor to operate at different conversion rates, increasing host control over the Si1145/46/47-M01.

When operating autonomously, the ALS has a slightly different interrupt structure compared to the Proximity Sensor. An interrupt can be generated to the host on every sample, or when the ambient light has changed.

The “Ambient Light Changed” interrupt is accomplished through two thresholds working together to implement a window. As long as the ambient light stays within the window defined by the two thresholds, the host is not interrupted. When the ambient light changes and either threshold is crossed, an interrupt is sent to the host, thereby allowing the host notification that the ambient light has changed. This can be used by the host to trigger a recalculation of the lux values.

The window can be applied to either the Visible Ambient Measurement, or the Infrared Ambient Measurement, but not both. However, monitoring the ambient change in either channel should allow notification that the ambient light level has changed.

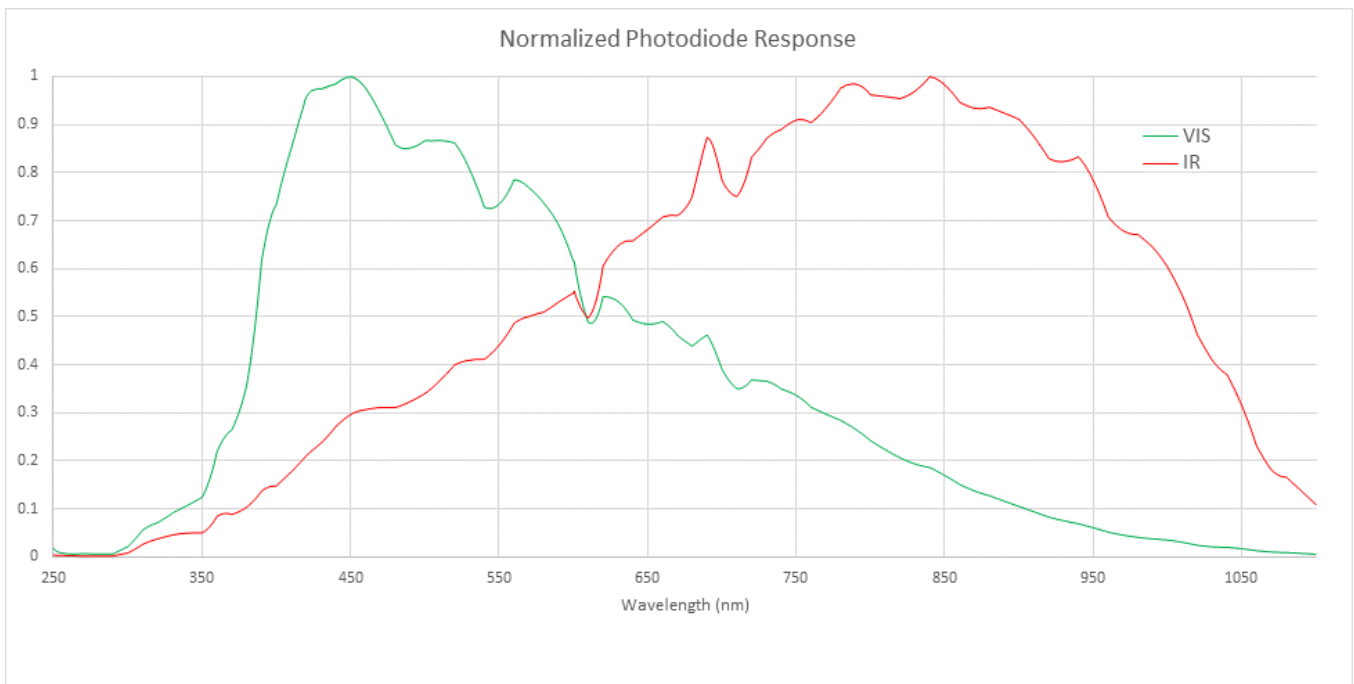

Figure 12. Photodiode Spectral Response to Visible and Infrared Light (Indicative)

2.4. Ultraviolet (UV) Index

The UV Index is a number linearly related to the intensity of sunlight reaching the earth and is weighted according to the CIE Erythral Action Spectrum as shown in Figure 13. This weighting is a standardized measure of human skin's response to different wavelengths of sunlight from UVB to UVA. The UV Index has been standardized by the World Health Organization and includes a simplified consumer UV exposure level as shown in Figure 14 and Figure 15.

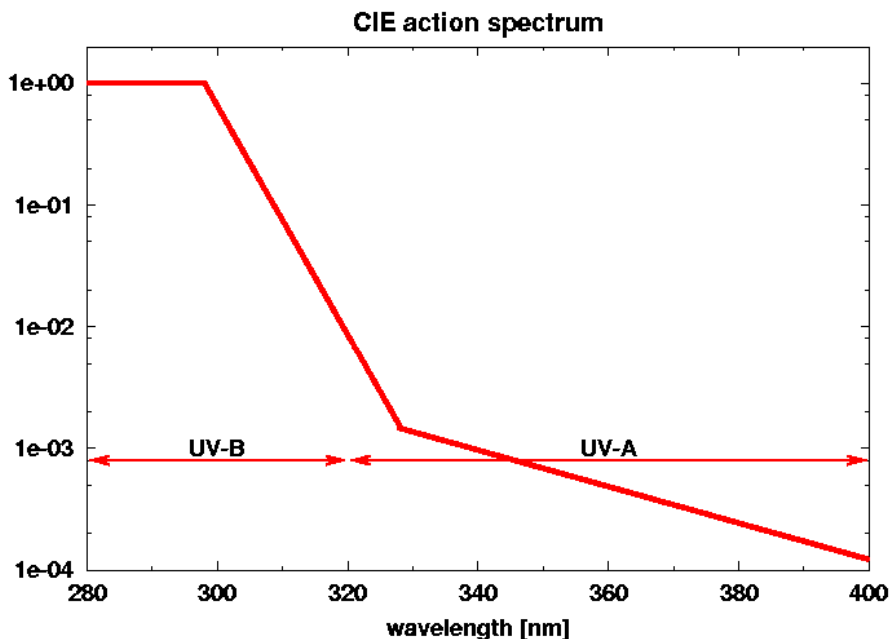

Figure 13. CIE Erythral Action Spectrum

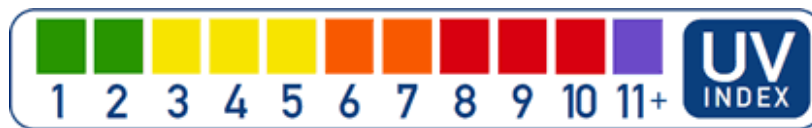

Figure 14. UV Index Scale



Figure 15. UV Levels

To enable UV reading, set the EN_UV bit in CHLIST, and configure UCOEF [0:3] to the default values of 0xDB, 0x8F, 0x01, and 0x00. Also set the VIS_RANGE and IR_RANGE bits. If the sensor will be under an overlay that is not 100% transmissive to sunlight, contact Silicon Labs for more information on adjusting these coefficients.

Typically, after 285 μ s, AUX_DATA will contain a 16-bit value representing 100 times the sunlight UV Index. Host software must divide the results from AUX_DATA by 100.

The accuracy of UV readings can be improved by using calibration parameters that are programmed into the Si1145/46/47-M01 at Silicon Labs' production facilities to adjust for normal part-to-part variation. The calibration parameters are recovered from the Si1145/46/47-M01 by writing Command Register @ address 0x18 with the value 0x12.

When the calibration parameters are recovered they show up at I²C registers 0x22 to 0x2D. These are the same registers used to report the VIS, IR, PS1, PS2, PS3, and AUX measurements.

The use of calibration parameters is documented in the file, Si114x_functions.h, which is part of the Si114x Programmer's Toolkit example source code and is downloadable from Silabs.com. The host code is expected to allocate memory for the SI114X_CAL_S structure. The si114x_calibration routine will then fill it up with the appropriate values.

Once the calibration parameters have been recovered the routine Si114x_set_ucoef is used to modify the default values that go into the UCOEF0 to UCOEF3 UV configuration registers to remove normal part-to-part variation.

The typical calibrated UV sensor response vs. calculated ideal UV Index is shown in Figure 16 for a large database of sunlight spectra from cloudy to sunny days and at various angles of the sun/time of day.

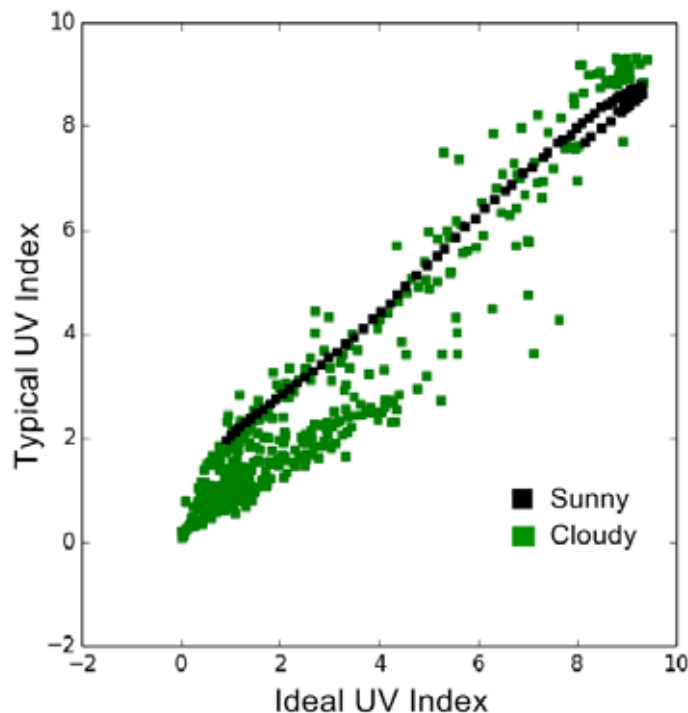

Figure 16. Calibrated UV Sensor Response vs. Calculated Ideal UV Index (AUX_DATA Measurement / 100)

Si1145/46/47-M01

2.5. Host Interface

The host interface to the Si1145/46/47-M01 consists of three pins:

- SCL
- SDA
- INT

SCL and SDA are standard open-drain pins as required for I²C operation.

The Si1145/46/47-M01 asserts the INT pin to interrupt the host processor. The INT pin is an open-drain output. A pull-up resistor is needed for proper operation. As an open-drain output, it can be shared with other open-drain interrupt sources in the system.

For proper operation, the Si1145/46/47-M01 is expected to fully complete its Initialization Mode prior to any activity on the I²C.

The INT, SCL, and SDA pins are designed so that it is possible for the Si1145/46/47-M01 to enter the Off Mode by software command without interfering with normal operation of other I²C devices on the bus.

The Si1145/46/47-M01 I²C slave address is 0x60. The Si1145/46/47-M01 also responds to the global address (0x00) and the global reset command (0x06). Only 7-bit I²C addressing is supported; 10-bit I²C addressing is not supported.

Conceptually, the I²C interface allows access to the Si1145/46/47-M01 internal registers. Table 15 on page 33 is a summary of these registers.

An I²C write access always begins with a start (or restart) condition. The first byte after the start condition is the I²C address and a read-write bit. The second byte specifies the starting address of the Si1145/46/47-M01 internal register. Subsequent bytes are written to the Si1145/46/47-M01 internal register sequentially until a stop condition is encountered. An I²C write access with only two bytes is typically used to set up the Si1145/46/47-M01 internal address in preparation for an I²C read.

The I²C read access, like the I²C write access, begins with a start or restart condition. In an I²C read, the I²C master then continues to clock SCK to allow the Si1145/46/47-M01 to drive the I²C with the internal register contents.

The Si1145/46/47-M01 also supports burst reads and burst writes. The burst read is useful in collecting contiguous, sequential registers. The Si1145/46/47-M01 register map was designed to optimize for burst reads for interrupt handlers, and the burst writes are designed to facilitate rapid programming of commonly used fields, such as thresholds registers.

The internal register address is a six-bit (bit 5 to bit 0) plus an Autoincrement Disable (on bit 6). The Autoincrement Disable is turned off by default. Disabling the autoincrementing feature allows the host to poll any single internal register repeatedly without having to keep updating the Si1145/46/47-M01 internal address every time the register is read.

It is recommended that the host should read PS or ALS measurements (in the I²C Register Map) when the Si1145/46/47-M01 asserts INT. Although the host can read any of the Si1145/46/47-M01's I²C registers at any time, care must be taken when reading 2-byte measurements outside the context of an interrupt handler. The host could be reading part of the 2-byte measurement when the internal sequencer is updating that same measurement coincidentally. When this happens, the host could be reading a hybrid 2-byte quantity whose high byte and low byte are parts of different samples. If the host must read these 2-byte registers outside the context of an interrupt handler, the host should “double-check” a measurement if the measurement deviates significantly from a previous reading.

I²C Broadcast Reset: The I²C Broadcast Reset should be sent prior to any I²C register access to the Si1145/46/47-M01. If any I²C register or parameter has already been written to the Si1145/46/47-M01 when the I²C Broadcast Reset is issued, the host must send a reset command and reinitialize the Si1145/46/47-M01 completely.

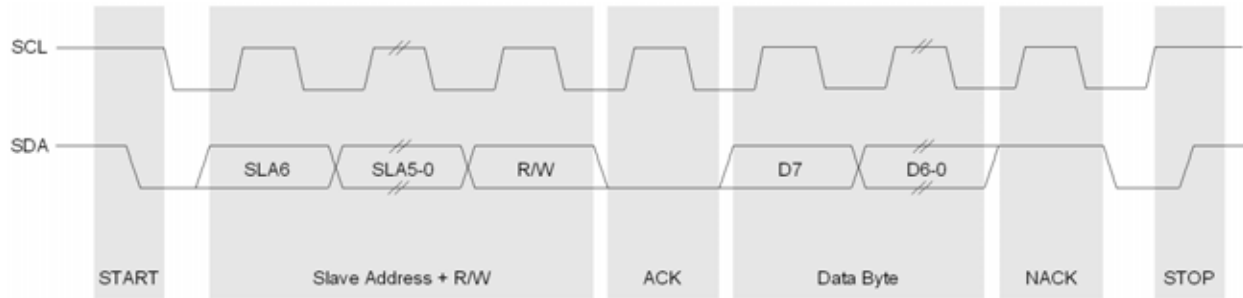

Figure 17. I²C Bit Timing Diagram



Figure 18. Host Interface Single Write

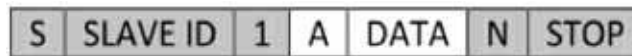

Figure 19. Host Interface Single Read

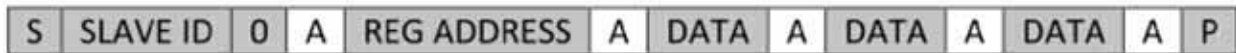

Figure 20. Host Interface Burst Write



Figure 21. Host Interface Burst Read

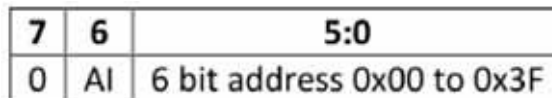

Figure 22. Si1145/46/47-M01 REG ADDRESS Format

Notes:

- Gray boxes are driven by the host to the Si1145/46/47-M01
- White boxes are driven by the Si1145/46/47-M01 to the host
- A = ACK or “acknowledge”
- N = NACK or “no acknowledge”
- S = START condition
- Sr = repeat START condition
- P = STOP condition
- AI = Disable Auto Increment when set

3. Operational Modes

The Si1145/46/47-M01 can be in one of many operational modes at any one time. It is important to consider the operational mode since the mode has an impact on the overall power consumption of the Si1145/46/47-M01. The various modes are:

- Off Mode
- Initialization Mode
- Standby Mode
- Forced Conversion Mode
- Autonomous Mode

3.1. Off Mode

The Si1145/46/47-M01 is in the Off Mode when V_{DD} is either not connected to a power supply or if the V_{DD} voltage is below the stated V_{DD_OFF} voltage described in the electrical specifications. As long as the parameters stated in Table 4, “LED Electro-Optical Characteristics*,” on page 10 are not violated, no current will flow through the Si1145/46/47-M01. In the Off Mode, the Si1145/46/47-M01 SCL and SDA pins do not interfere with other I²C devices on the bus. The LED pins will not draw current through the infrared diodes. Keeping V_{DD} less than V_{DD_OFF} is not intended as a method of achieving lowest system current draw. The reason is that the ESD protection devices on the SCL, SDA and INT pins also form a current path through V_{DD} . If V_{DD} is grounded for example, then, current flow from system power to system ground through the SCL, SDA and INT pull-up resistors and the ESD protection devices.

Allowing V_{DD} to be less than V_{DD_OFF} is intended to serve as a hardware method of resetting the Si1145/46/47-M01 without a dedicated reset pin.

The Si1145/46/47-M01 can also reenter the Off Mode upon receipt of either a general I²C reset or if a software reset sequence is initiated. When one of these software methods is used to enter the Off Mode, the Si1145/46/47-M01 typically proceeds directly from the Off Mode to the Initialization Mode.

3.2. Initialization Mode

When power is applied to V_{DD} and is greater than the minimum V_{DD} Supply Voltage stated in Table 1, “Recommended Operating Conditions,” on page 5, the Si1145/46/47-M01 enters its Initialization Mode. In the Initialization Mode, the Si1145/46/47-M01 performs its initial startup sequence. Since the I²C may not yet be active, it is recommended that no I²C activity occur during this brief Initialization Mode period. The “Start-up time” specification in Table 1 is the minimum recommended time the host needs to wait before sending any I²C accesses following a power-up sequence. After Initialization Mode has completed, the Si1145/46/47-M01 enters Standby Mode. The host must write 0x17 to the HW_KEY register for proper operation.

3.3. Standby Mode

The Si1145/46/47-M01 spends most of its time in Standby Mode. After the Si1145/46/47-M01 completes the Initialization Mode sequence, it enters Standby mode. While in Standby Mode, the Si1145/46/47-M01 does not perform any Ambient Light measurements or Proximity Detection functions. However, the I²C interface is active and ready to accept reads and writes to the Si1145/46/47-M01 registers. The internal Digital Sequence Controller is in its sleep state and does not draw much power. In addition, the INT output retains its state until it is cleared by the host.

I²C accesses do not necessarily cause the Si1145/46/47-M01 to exit the Standby Mode. For example, reading Si1145/46/47-M01 registers is accomplished without needing the Digital Sequence Controller to wake from its sleep state.

3.4. Forced Conversion Mode

The Si1145/46/47-M01 can operate in Forced Conversion Mode under the specific command of the host processor. The Forced Conversion Mode is entered if either the ALS_FORCE or the PS_FORCE command is sent. Upon completion of the conversion, the Si1145/46/47-M01 can generate an interrupt to the host if the corresponding interrupt is enabled. It is possible to initiate both an ALS and multiple PS measurements with one command register write access by using the PSALS_FORCE command.

3.5. Autonomous Operation Mode

The Si1145/46/47-M01 can be placed in the Autonomous Operation Mode where measurements are performed automatically without requiring an explicit host command for every measurement. The PS_AUTO, ALS_AUTO and PSALS_AUTO commands are used to place the Si1145/46/47-M01 in the Autonomous Operation Mode.

The Si1145/46/47-M01 updates the I²C registers for PS and ALS automatically. Each measurement is allocated a 16-bit register in the I²C map. It is possible to operate the Si1145/46/47-M01 without interrupts. When doing so, the host poll rate must be at least twice the frequency of the conversion rates for the host to always receive a new measurement. The host can also choose to be notified when these new measurements are available by enabling interrupts.

The conversion frequencies for the PS and ALS measurements are set up by the host prior to the PS_AUTO, ALS_AUTO, or PSALS_AUTO commands.

4. Programming Guide

4.1. Command and Response Structure

All Si1145/46/47-M01 I²C registers (except writes to the COMMAND register) are read or written without waking up the internal sequencer. A complete list of the I²C registers can be found in "4.5. I2C Registers" on page 33. In addition to the I²C Registers, RAM parameters are memory locations maintained by the internal sequencer. These RAM Parameters are accessible through a Command Protocol (see "4.6. Parameter RAM" on page 48). A complete list of the RAM Parameters can be found in "4.6. Parameter RAM" on page 48.

The Si1145/46/47-M01 can operate either in Forced Measurement or Autonomous Mode. When in Forced Measurement mode, the Si1145/46/47-M01 does not make any measurements unless the host specifically requests the Si1145/46/47-M01 to do so via specific commands (refer to the Section 3.2). The CHLIST parameter needs to be written so that the Si1145/46/47-M01 would know which measurements to make. The parameter MEAS_RATE, when zero, places the internal sequencer in Forced Measurement mode. When in Forced Measurement mode, the internal sequencer wakes up only when the host writes to the COMMAND register. The power consumption is lowest in Forced Measurement mode (MEAS_RATE = 0).

The Si1145/46/47-M01 operates in Autonomous Operation mode when MEAS_RATE is non-zero. The MEAS_RATE represents the time interval at which the Si1145/46/47-M01 wakes up periodically. Once the internal sequencer has awoken, up to three proximity measurements are made (PS1, PS2, and PS3) depending on which measurements are enabled via the lower bits of the CHLIST parameter. All three PS measurements are performed in sequence beginning with the PS1 measurement channel. Up to three measurements are made (ALS_VIS, ALS_IR, and AUX) depending on which measurements are enabled via the upper bits of the CHLIST parameter. All three measurements are made in the following sequence: ALS_VIS, ALS_IR, and AUX.

The operation of the Si1145/46/47-M01 can be described as two measurement groups bound by some common factors. The PS Measurement group consists of the three PS measurements while the ALS Measurement group consists of the Visible Light Ambient Measurement (ALS_VIS), the Infrared Light Ambient Measurement (ALS_IR) and the Auxiliary measurement (AUX). Each measurement group has three measurements each. The Channel List (CHLIST) parameter enables the specific measurements for that measurement grouping.

Each measurement (PS1, PS2, PS3, ALS_VIS, ALS_IR, AUX) are controlled through a combination of I2C Register or Parameter RAM. Tables 7 to 9 below summarize the properties and resources used for each measurement.

4.2. Command Protocol

The I²C map implements a bidirectional message box between the host and the Si1145/46/47-M01 Sequencer. Host-writable I²C registers facilitate host-to-Si1145/46/47-M01 communication, while read-only I²C registers are used for Si1145/46/47-M01-to-host communication.

Unlike the other host-writable I²C registers, the COMMAND register causes the internal sequencer to wake up from Standby mode to process the host request.

When a command is executed, the RESPONSE register is updated. Typically, when there is no error, the upper four bits are zeroes. To allow command tracking, the lower four bits implement a 4-bit circular counter. In general, if the upper nibble of the RESPONSE register is non-zero, this indicates an error or the need for special processing.

The PARAM_WR and PARAM_RD registers are additional mailbox registers.

In addition to the registers in the I²C map, there are environmental parameters accessible through the Command/Response interface. These parameters are stored in the internal ram space. These parameters generally take more I²C accesses to read and write. The Parameter RAM is described in "4.6. Parameter RAM" on page 48.

For every write to the Command register, the following sequence is required:

1. Write 0x00 to Command register to clear the Response register.
2. Read Response register and verify contents are 0x00.
3. Write Command value from Table 5 into Command register.
4. *Read the Response register and verify contents are now non-zero.* If contents are still 0x00, repeat these steps.

The Response register will be incremented upon the successful completion of a Command. If the Response register remains 0x00 for over 25 ms after the Command write, the entire Command process should be repeated from Step 1.

Step 4 above is not applicable to the Reset Command because the device will reset itself and does not increment the Response register after reset. No Commands should be issued to the device for at least 1 ms after a Reset is issued.

Table 6. Command Register Summary

COMMAND Register		PARAM_W R Register	PARAM_RD Register	Error Code in RESPONSE Register	Description
Name	Encoding				
PARAM_QUERY	100 aaaaa	—	nnnn nnnn	✓	Reads the parameter pointed to by bitfield [4:0] and writes value to PARAM_RD. See Table 11 for parameters.
PARAM_SET	101 aaaaa	dddd dddd	nnnn nnnn	✓	Sets parameter pointed by bitfield [4:0] with value in PARAM_WR, and writes value out to PARAM_RD. See Table 11 for parameters.
NOP	000 00000	—	—	✓	Forces a zero into the RESPONSE register
RESET	000 00001	—	—	✓	Performs a software reset of the firmware
BUSADDR	000 00010	—	—	—	Modifies I ² C address
Reserved	000 00011	—	—	—	—
Reserved	000 00100	—	—	—	—
PS_FORCE	000 00101	—	—	✓	Forces a single PS measurement
ALS_FORCE	000 00110	—	—	✓	Forces a single ALS measurement
PSALS_FORCE	000 00111	—	—	✓	Forces a single PS and ALS measurement
Reserved	000 01000	—	—	—	—
PS_PAUSE	000 01001	—	—	✓	Pauses autonomous PS
ALS_PAUSE	000 01010	—	—	✓	Pauses autonomous ALS
PSALS_PAUSE	000 01011	—	—	✓	Pauses PS and ALS
Reserved	000 01100	—	—	✓	—
PS_AUTO	000 01101	—	—	✓	Starts/Restarts an autonomous PS Loop
ALS_AUTO	000 01110	—	—	✓	Starts/Restarts an autonomous ALS Loop
PSALS_AUTO	000 01111	—	—	✓	Starts/Restarts autonomous ALS and PS loop
Reserved	000 1xxxx	—	—	—	—

Table 7. Response Register Error Codes

RESPONSE Register	Description
0000 cccc	NO_ERROR. The lower bit is a circular counter and is incremented every time a command has completed. This allows the host to keep track of commands sent to the Si1145/46/47-M01. The circular counter may be cleared using the NOP command.
1000 0000	INVALID_SETTING. An invalid setting was encountered. Clear using the NOP command.
1000 1000	PS1_ADC_OVERFLOW. Indicates proximity channel one conversion overflow.
1000 1001	PS2_ADC_OVERFLOW. Indicates proximity channel two conversion overflow.
1000 1010	PS3_ADC_OVERFLOW. Indicates proximity channel three conversion overflow.
1000 1100	ALS_VIS_ADC_OVERFLOW. Indicates visible ambient light channel conversion overflow.
1000 1101	ALS_IR_ADC_OVERFLOW. Indicates infrared ambient light channel conversion overflow.
1000 1110	AUX_ADC_OVERFLOW. Indicates auxiliary channel conversion overflow.

4.3. Resource Summary

Table 8. Resource Summary for Interrupts

Measurement Channel	Channel Enable	Interrupt Status Output	Interrupt Enable	Autonomous Measurement Time Base
Proximity Sense 1	EN_PS1 in CHLIST[0]	PS1_INT in IRQ_STATUS[2]	PS1_IE in IRQ_ENABLE[2]	MEAS_RATE[15:0]
Proximity Sense 2	EN_PS2 in CHLIST[1]	PS2_INT in IRQ_STATUS[3]	PS2_IE in IRQ_ENABLE[3]	
Proximity Sense 3	EN_PS3 in CHLIST[2]	PS3_INT in IRQ_STATUS[4]	PS3_EN in IRQ_ENABLE[4]	
ALS Visible	EN_ALS_VIS in CHLIST[4]	ALS_INT[1:0] in IRQ_STATUS[1:0]	ALS_IE[1:0] in IRQ_ENABLE[1:0]	
ALS IR	EN_ALS_IR in CHLIST[5]			
Auxiliary Measurement	EN_AUX in CHLIST[6]			

Table 9. Resource Summary for LED Choice and ADC Parameters

Measurement Channel	LED Selection	ADC Mode	ADC Output	ADC Input Source	ADC Recovery Count	ADC High Signal Mode	ADC Clock Divider	ADC Alignment
Proximity Sense 1	PS1_LED[2:0] in PSLED12_SELECT[2:0]	PS_ADC_MODE in PS_ADC_MISC[2]	PS1_DATA1[7:0] / PS1_DATA0[7:0]	PS1_ADCMUX[7:0]	PS_ADC_REC in PS_ADC_COUNTER [6:4]	PS_RANGE in PS_ADC_MISC[5]	PS_ADC_GAIN[3:0]	PS1_ALIGN in PS_ENCODING[4]
Proximity Sense 2	PS2_LED[2:0] in PSLED12_SELECT[6:4]		PS2_DATA1[7:0] / PS2_DATA0[7:0]	PS2_ADCMUX[7:0]				PS2_ALIGN in PS_ENCODING[5]
Proximity Sense 3	PS3_LED[2:0] in PSLED3_SELECT[2:0]		PS3_DATA1[7:0] / PS3_DATA0[7:0]	PS3_ADCMUX[7:0]				PS3_ALIGN in PS_ENCODING[6]
ALS Visible			ALS_VIS_DATA1 / ALS_VIS_DATA0		VIS_ADC_REC in ALS_VIS_ADC_COUNTER [6:4]	VIS_RANGE in ALS_VIS_ADC_MISC[5]	ALS_VIS_ADC_GAIN [3:0]	ALS_VIS_ALIGN in ALS_ENCODING[4]
ALS IR			ALS_IR_DATA1[7:0] / ALS_IR_DATA0[7:0]		IR_ADC_REC in ALS_IR_ADC_COUNTER [6:4]	IR_RANGE in ALS_IR_ADC_MISC[5]	ALS_IR_ADC_GAIN [3:0]	ALS_IR_ALIGN in ALS_ENCODING[5]
Auxiliary Measurement			AUX_DATA1[7:0] / AUX_DATA0[7:0]		AUX_ADCMUX[7:0]			

Table 10. Resource Summary for Hardware Pins

Pin Name	LED Current Drive	Output Drive Disable	Analog Voltage Input Enable
LED1	LED1_I in PSLED12[3:0]		ANA_IN_KEY[31:0]
LED2	LED2_I in PSLED12[7:4]	HW_KEY[7:0]	ANA_IN_KEY[31:0]
LED3	LED3_I in PSLED3[3:0]	HW_KEY[7:0]	
INT		INT_OE in INT_CFG[0]	ANA_IN_KEY[31:0]

The interrupts of the Si1145/46/47-M01 are controlled through the INT_CFG, IRQ_ENABLE, IRQ_MODE1, IRQ_MODE2 and IRQ_STATUS registers.

The INT hardware pin is enabled through the INT_OE bit in the INT_CFG register. The hardware essentially performs an AND function between the IRQ_ENABLE register and IRQ_STATUS register. After this AND function, if any bits are set, the INT pin is asserted. The host is responsible for clearing the interrupt by writing to the IRQ_STATUS register. When the specific bits of the IRQ_STATUS register is written with 1, that specific IRQ_STATUS bit is cleared.

Typically, the host software is expected to read the IRQ_STATUS register, stores a local copy, and then writes the same value back to the IRQ_STATUS to clear the interrupt source. The INT_CFG register is normally written with 1.

The IRQ_MODE1, IRQ_MODE2 and IRQ_ENABLE registers work together to define how the internal sequencer sets bits in the IRQ_STATUS register (and as a consequence, asserting the INT pin).

The PS1 interrupts are described in Table 10. The PS2 interrupts are described in Table 12. The PS3 interrupts are described in Table 13. The ALS interrupts are described in Table 14.

Table 11. PS1 Channel Interrupt Resources

IRQ_ENABLE[2]	Description
PS1_IE	
0	No PS1 Interrupts
1	PS1_INT set after every PS1 sample

Table 12. PS2 Channel Interrupt Resources

IRQ_ENABLE[3]	Description
PS2_IE	
0	No PS2 Interrupts
1	PS2_INT set after every PS2 sample

Table 13. PS3 Channel Interrupt Resources

IRQ_ENABLE[4]	Description
PS3_IE	
0	No PS3 Interrupts
1	PS3_INT set after every PS3 sample

Table 14. Ambient Light Sensing Interrupt Resources

IRQ_ENABLE[1:0]		Description
ALS_IE[1:0]		
0	0	No ALS Interrupts
0	1	ALS_INT set after every ALS_VIS or UV sample

Si1145/46/47-M01

4.4. Signal Path Software Model

The following diagram gives an overview of the signal paths, along with the I²C register and RAM Parameter bit fields that control them. Sections with detailed descriptions of the I²C registers and Parameter RAM follow.

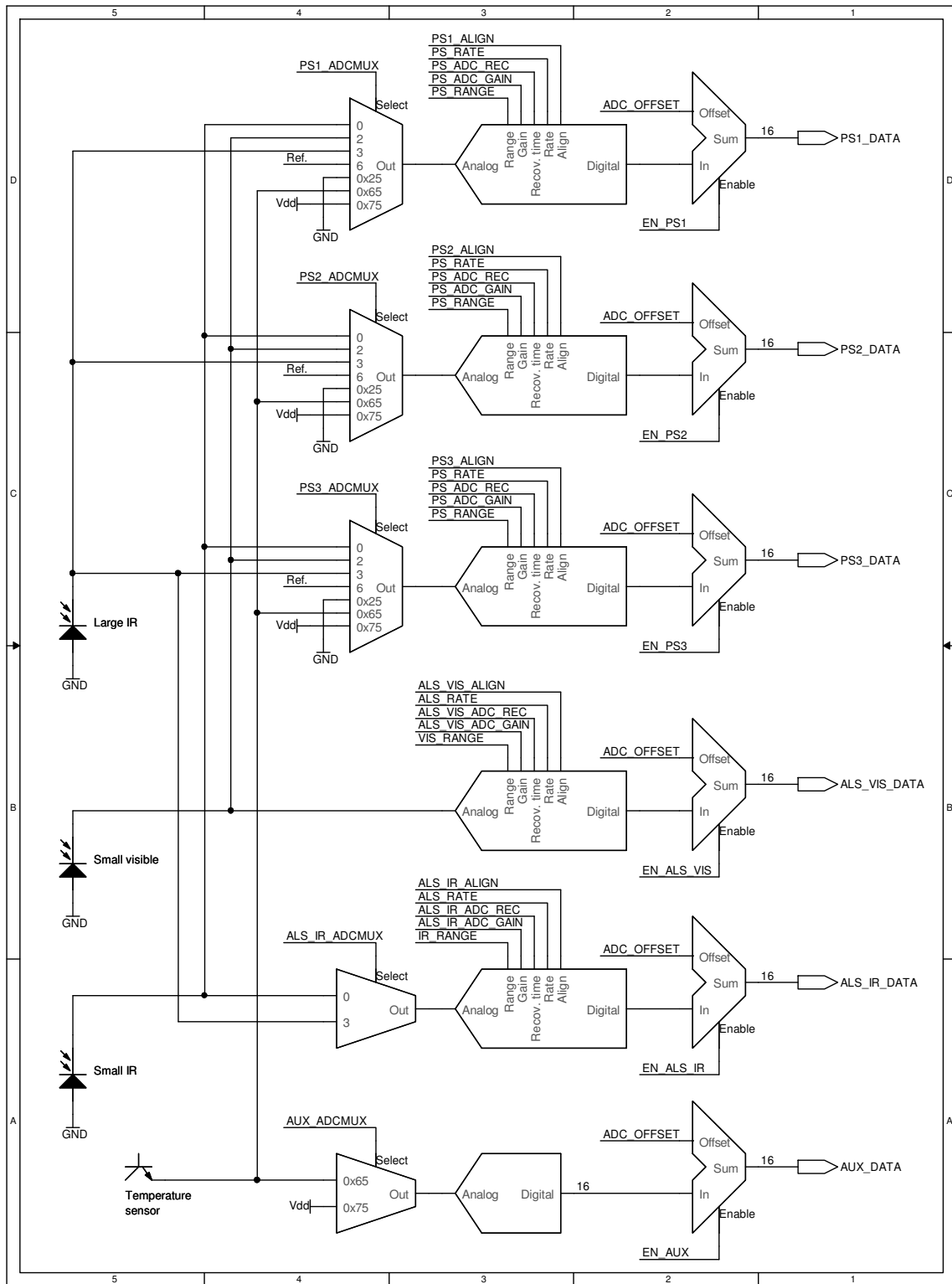

Figure 23. Signal Path Programming Model

4.5. I²C RegistersTable 15. I²C Register Summary

I ² C Register Name	Address	7	6	5	4	3	2	1	0
PART_ID	0x00	PART_ID							
REV_ID	0x01	REV_ID							
SEQ_ID	0x02	SEQ_ID							
INT_CFG	0x03								INT_OE
IRQ_ENABLE	0x04				PS3_IE	PS2_IE	PS1_IE		ALS_IE
IRQ_MODE1	0x05	PS2_IM		PS1_IM			ALS_IM		
IRQ_MODE2	0x06					CMD_IM		PS3_IM	
HW_KEY	0x07	HW_KEY							
MEAS_RATE	0x08	MEAS_RATE							
ALS_RATE	0x09	ALS_RATE							
Reserved	0x0A-0x0E	Reserved							
PS_LED21	0x0F	LED2_I				LED1_I			
PS_LED3	0x10					LED3_I			
Reserved	0x11-0x12	Reserved							
UCOEF0	0x13	UCOEF0							
UCOEF1	0x14	UCOEF1							
UCOEF2	0x15	UCOEF2							
UCOEF3	0x16	UCOEF3							
PARAM_WR	0x17	PARAM_WR							
COMMAND	0x18	COMMAND							
RESPONSE	0x20	RESPONSE							
IRQ_STATUS	0x21			CMD_INT	PS3_INT	PS2_INT	PS1_INT	ALS_INT	
ALS_VIS_DATA0	0x22	ALS_VIS_DATA0							
ALS_VIS_DATA1	0x23	ALS_VIS_DATA1							
ALS_IR_DATA0	0x24	ALS_IR_DATA0							

Table 15. I²C Register Summary (Continued)

I ² C Register Name	Address	7	6	5	4	3	2	1	0
ALS_IR_DATA1	0x25	ALS_IR_DATA1							
PS1_DATA0	0x26	PS1_DATA0							
PS1_DATA1	0x27	PS1_DATA1							
PS2_DATA0	0x28	PS2_DATA0							
PS2_DATA1	0x29	PS2_DATA1							
PS3_DATA0	0x2A	PS3_DATA0							
PS3_DATA1	0x2B	PS3_DATA1							
AUX_DATA0/ UVINDEX0	0x2C	AUX_DATA0/UVINDEX0							
AUX_DATA1/ UVINDEX1	0x2D	AUX_DATA1/UVINDEX1							
PARAM_RD	0x2E	PARAM_RD							
CHIP_STAT	0x30						RUN- NING	SUSPEND	SLEEP
ANA_IN_KEY	0x3B– 0x3E	ANA_IN_KEY							

PART_ID @ 0x00

Bit	7	6	5	4	3	2	1	0
Name	PART_ID							
Type	R							

Reset value = 0100 0101 (Si1145-M01)

Reset value = 0100 0110 (Si1146-M01)

Reset value = 0100 0111 (Si1147-M01)

REV_ID @ 0x1

Bit	7	6	5	4	3	2	1	0
Name	REV_ID							
Type	R							

Reset value = 0000 0000

SEQ_ID @ 0x02

Bit	7	6	5	4	3	2	1	0
Name	SEQ_ID							
Type	R							

Reset value = 0000 1000

Bit	Name	Function
7:0	SEQ_ID	Sequencer Revision. 0x08 Si1145/46/47-M01 (MAJOR_SEQ = 1, MINOR_SEQ = 0)

Si1145/46/47-M01

INT_CFG @ 0x03

Bit	7	6	5	4	3	2	1	0	
Name								INT_OE	
Type								RW	

Reset value = 0000 0000

Bit	Name	Function
7:2	Reserved	Reserved.
0	INT_OE	INT Output Enable. INT_OE controls the INT pin drive. 0: INT pin is never driven. 1: INT pin driven low whenever an IRQ_STATUS and its corresponding IRQ_ENABLE bits match.

IRQ_ENABLE @ 0x04

Bit	7	6	5	4	3	2	1	0
Name			CMD_IE	PS3_IE	PS2_IE	PS1_IE		ALS_IE
Type			RW	RW	RW	RW		RW

Reset value = 0000 0000

Bit	Name	Function
7:6	Reserved	Reserved.
5	CMD_IE	Command Interrupt Enable. Enables interrupts based on COMMAND/RESPONSE activity. 0: INT never asserts due to COMMAND/RESPONSE interface activity. 1: Assert INT pin whenever CMD_INT is set by the internal sequencer.
4	PS3_IE	PS3 Interrupt Enable. Enables interrupts based on PS3 Channel Activity. 0: INT never asserts due to PS3 Channel activity. 1: Assert INT pin whenever PS3_INT is set by the internal sequencer.
3	PS2_IE	PS2 Interrupt Enable. Enables interrupts based on PS2 Channel Activity. 0: INT never asserts due to PS2 Channel activity. 1: Assert INT pin whenever PS2_INT is set by the internal sequencer.
2	PS1_IE	PS1 Interrupt Enable. Enables interrupts based on PS1 Channel Activity. 0: INT never asserts due to PS1 Channel activity. 1: Assert INT pin whenever PS1_INT is set by the internal sequencer.
1	Reserved	Reserved.
0	ALS_IE	ALS Interrupt Enable. Enables interrupts when VIS bit or UV bit in CHLIST is enabled. 0: INT never asserts due to VIS or UV activity. 1: Assert INT pin whenever VIS or UV measurements are ready.

Si1145/46/47-M01

HW_KEY @ 0x07

Bit	7	6	5	4	3	2	1	0
Name	HW_KEY							
Type	RW							

Reset value = 0000 0000

Bit	Name	Function
7:0	HW_KEY	The system must write the value 0x17 to this register for proper Si1145/46/47-M01 operation.

MEAS_RATE0: MEAS_RATE Data Word Low Byte @ 0x08

Bit	7	6	5	4	3	2	1	0
Name	MEAS_RATE[7:0]							
Type	RW							

Reset value = 0000 0000

Bit	Name	Function
7:0	MEAS_RATE[7:0]	MEAS_RATE1 and MEAS_RATE0 together form a 16-bit value: MEAS_RATE [15:0]. The 16-bit value, when multiplied by 31.25 us, represents the time duration between wake-up periods where measurements are made. Once the device wakes up, all measurements specified in CHLIST are made. Note that for the Si1145/6/7 with SEQ_ID=0x01, there is a code error that places MEAS_RATE0 at 0x0A with MEAS_RATE1 at 0x08 instead. This will be fixed in future revisions of the Si1145/6/7.

MEAS_RATE1: MEAS_RATE Data Word High Byte @ 0x09

Bit	7	6	5	4	3	2	1	0
Name	MEAS_RATE[15:8]							
Type	RW							

Reset value = 0000 0000

Bit	Name	Function
7:0	MEAS_RATE[15:8]	MEAS_RATE1 and MEAS_RATE0 together form a 16-bit value: MEAS_RATE[15:0]. The 16-bit value, when multiplied by 31.25 ms, represents the time duration between wake-up periods where measurements are made. Once the device wakes up, all measurements specified in CHLIST are made. Note that for the Si1145/6/7 with SEQ_ID=0x01, there is a code error that places MEAS_RATE0 at 0x0A and MEAS_RATE1 at 0x08 instead. This will be fixed in future revisions of the Si1145/6/7.

PS_LED21 @ 0x0F

Bit	7	6	5	4	3	2	1	0
Name	LED2_I				LED1_I			
Type	RW				RW			

Reset value = 0000 0000

Bit	Name	Function
7:4	LED2_I	LED2_I Represents the irLED current sunk by the LED2 pin during a PS measurement. On the Si1145, these bits must be set to zero.
3:0	LED1_I	LED1_I Represents the irLED current sunk by the LED1 pin during a PS measurement. LED3_I, LED2_I, and LED1_I current encoded as follows: 0000: No current 0001: Minimum current 1111: Maximum current Refer to Table 2, "Performance Characteristics ¹ ," on page 6 for LED current values.

Si1145/46/47-M01

PS_LED3 @ 0x10

Bit	7	6	5	4	3	2	1	0
Name	LED3_I							
Type	RW							

Reset value = 0000 0000

Bit	Name	Function
7:4	Reserved	Reserved.
3:0	LED3_I	LED3_I Represents the irLED current sunk by the LED3 pin during a PS measurement. See PS_LED21 Register for additional details.

PARAM_WR @ 0x17

Bit	7	6	5	4	3	2	1	0
Name	PARAM_WR							
Type	RW							

Reset value = 0000 0000

Bit	Name	Function
7:0	PARAM_WR	Mailbox register for passing parameters from the host to the sequencer.

COMMAND @ 0x18

Bit	7	6	5	4	3	2	1	0
Name	COMMAND							
Type	RW							

Reset value = 0000 0000

Bit	Name	Function
7:0	COMMAND	COMMAND Register. The COMMAND Register is the primary mailbox register into the internal sequencer. Writing to the COMMAND register is the only I ² C operation that wakes the device from standby mode.

RESPONSE @ 0x20

Bit	7	6	5	4	3	2	1	0
Name	RESPONSE							
Type	RW							

Reset value = 0000 0000

Bit	Name	Function
7:0	RESPONSE	<p>The Response register is used in conjunction with command processing. When an error is encountered, the response register will be loaded with an error code. All error codes will have the MSB is set.</p> <p>The error code is retained until a RESET or NOP command is received by the sequencer. Other commands other than RESET or NOP will be ignored. However, any autonomous operation in progress continues normal operation despite any error.</p> <p>0x00–0x0F: No Error. Bits 3:0 form an incrementing roll-over counter. The roll over counter in bit 3:0 increments when a command has been executed by the Si1145/46/47-M01. Once autonomous measurements have started, the execution timing of any command becomes non-deterministic since a measurement could be in progress when the COMMAND register is written. The host software must make use of the rollover counter to ensure that commands are processed.</p> <p>0x80: Invalid Command Encountered during command processing 0x88: ADC Overflow encountered during PS1 measurement 0x89: ADC Overflow encountered during PS2 measurement 0x8A: ADC Overflow encountered during PS3 measurement 0x8C: ADC Overflow encountered during ALS-VIS measurement 0x8D: ADC Overflow encountered during ALS-IR measurement 0x8E: ADC Overflow encountered during AUX measurement</p>

Si1145/46/47-M01

IRQ_STATUS @ 0x21

Bit	7	6	5	4	3	2	1	0
Name			CMD_INT	PS3_INT	PS2_INT	PS1_INT	ALS_INT	
Type			RW	RW	RW	RW	RW	

Reset value = 0000 0000

Bit	Name	Function
7:6	Reserved	Reserved.
5	CMD_INT	Command Interrupt Status.
4	PS3_INT	PS3 Interrupt Status.
3	PS2_INT	PS3 Interrupt Status.
2	PS1_INT	PS1 Interrupt Status.
1:0	ALS_INT	ALS Interrupt Status. (Refer to Table 13 for encoding.)

***Note:** If the corresponding IRQ_ENABLE bit is also set when the IRQ_STATUS bit is set, the INT pin is asserted.

ALS_VIS_DATA0: ALS_VIS_DATA Data Word Low Byte @ 0x22

Bit	7	6	5	4	3	2	1	0
Name	ALS_VIS_DATA[7:0]							
Type	RW							

Reset value = 0000 0000

Bit	Name	Function
7:0	ALS_VIS_DATA[7:0]	ALS VIS Data LSB. Once autonomous measurements have started, this register must be read after INT has asserted but before the next measurement is made. Refer to AN498 "Designer's Guide" Section 5.6.2 "Host Interrupt Latency."

ALS_VIS_DATA1: ALS_VIS_DATA Data Word High Byte @ 0x23

Bit	7	6	5	4	3	2	1	0
Name	ALS_VIS_DATA[15:8]							
Type	RW							

Reset value = 0000 0000

Bit	Name	Function
7:0	ALS_VIS_DATA[15:8]	ALS VIS Data MSB. Once autonomous measurements have started, this register must be read after INT has asserted but before the next measurement is made. Refer to AN498 "Designer's Guide" Section 5.6.2 "Host Interrupt Latency."

ALS_IR_DATA0: ALS_IR_DATA Data Word Low Byte@ 0x24

Bit	7	6	5	4	3	2	1	0
Name	ALS_IR_DATA[7:0]							
Type	RW							

Reset value = 0000 0000

Bit	Name	Function
7:0	ALS_IR_DATA[7:0]	ALS IR Data LSB. Once autonomous measurements have started, this register must be read after INT has asserted but before the next measurement is made. Refer to AN498 "Designer's Guide" Section 5.6.2 "Host Interrupt Latency."

ALS_IR_DATA1: ALS_IR_DATA Data Word High Byte @ 0x25

Bit	7	6	5	4	3	2	1	0
Name	ALS_IR_DATA[15:8]							
Type	RW							

Reset value = 0000 0000

Bit	Name	Function
7:0	ALS_IR_DATA[15:8]	ALS IR Data MSB. Once autonomous measurements have started, this register must be read after INT has asserted but before the next measurement is made. Refer to AN498 "Designer's Guide" Section 5.6.2 "Host Interrupt Latency."

Si1145/46/47-M01

PS1_DATA0: PS1_DATA Data Word Low Byte @ 0x26

Bit	7	6	5	4	3	2	1	0
Name	PS1_DATA[7:0]							
Type	RW							

Reset value = 0000 0000

Bit	Name	Function
7:0	PS1_DATA[7:0]	PS1 Data LSB. Once autonomous measurements have started, this register must be read after INT has asserted but before the next measurement is made. Refer to AN498 "Designer's Guide" Section 5.6.2 "Host Interrupt Latency."

PS1_DATA1: PS1_DATA Data Word High Byte @ 0x27

Bit	7	6	5	4	3	2	1	0
Name	PS1_DATA[15:8]							
Type	RW							

Reset value = 0000 0000

Bit	Name	Function
7:0	PS1_DATA[15:8]	PS1 Data MSB. Once autonomous measurements have started, this register must be read after INT has asserted but before the next measurement is made. Refer to AN498 "Designer's Guide" Section 5.6.2 "Host Interrupt Latency."

PS2_DATA0: PS2_DATA Data Word Low Byte @ 0x28

Bit	7	6	5	4	3	2	1	0
Name	PS2_DATA[7:0]							
Type	RW							

Reset value = 0000 0000

Bit	Name	Function
7:0	PS2_DATA[7:0]	PS2 Data LSB. Once autonomous measurements have started, this register must be read after INT has asserted but before the next measurement is made. Refer to AN498 "Designer's Guide" Section 5.6.2 "Host Interrupt Latency."

PS2_DATA1: PS2_DATA Data Word High Byte @ 0x29

Bit	7	6	5	4	3	2	1	0
Name	PS2_DATA[15:8]							
Type	RW							

Reset value = 0000 0000

Bit	Name	Function
7:0	PS2_DATA[15:8]	PS2 Data MSB. Once autonomous measurements have started, this register must be read after INT has asserted but before the next measurement is made. Refer to AN498 "Designer's Guide" Section 5.6.2 "Host Interrupt Latency."

PS3_DATA0: PS3_DATA Data Word Low Byte @ 0x2A

Bit	7	6	5	4	3	2	1	0
Name	PS3_DATA[7:0]							
Type	RW							

Reset value = 0000 0000

Bit	Name	Function
7:0	PS3_DATA[7:0]	PS3 Data LSB. Once autonomous measurements have started, this register must be read after INT has asserted but before the next measurement is made. Refer to AN498 "Designer's Guide" Section 5.6.2 "Host Interrupt Latency."

PS3_DATA1: PS3_DATA Data Word High Byte @ 0x2B

Bit	7	6	5	4	3	2	1	0
Name	PS3_DATA[15:8]							
Type	RW							

Reset value = 0000 0000

Bit	Name	Function
7:0	PS3_DATA[15:8]	PS3 Data MSB. Once autonomous measurements have started, this register must be read after INT has asserted but before the next measurement is made. Refer to AN498 "Designer's Guide" Section 5.6.2 "Host Interrupt Latency."

Si1145/46/47-M01

AUX_DATA0/UVINDEX0: AUX_DATA Data Word Low Byte @ 0x2C

Bit	7	6	5	4	3	2	1	0
Name	AUX_DATA[7:0]							
Type	RW							

Reset value = 0000 0000

Bit	Name	Function
7:0	AUX_DATA[7:0]	AUX Data LSB. Once autonomous measurements have started, this register must be read after INT has asserted but before the next measurement is made. Refer to AN498 "Designer's Guide" Section 5.6.2 "Host Interrupt Latency."

AUX_DATA1/UVINDEX1: AUX_DATA Data Word High Byte @ 0x2D

Bit	7	6	5	4	3	2	1	0
Name	AUX_DATA[15:8]							
Type	RW							

Reset value = 0000 0000

Bit	Name	Function
7:0	AUX_DATA[15:8]	AUX Data MSB. Once autonomous measurements have started, this register must be read after INT has asserted but before the next measurement is made. Refer to AN498 "Designer's Guide" Section 5.6.2 "Host Interrupt Latency."

PARAM_RD @ 0x2E

Bit	7	6	5	4	3	2	1	0
Name	PARAM_RD							
Type	RW							

Reset value = 0000 0000

Bit	Name	Function
7:0	PARAM_RD	Mailbox register for passing parameters from the sequencer to the host.

CHIP_STAT @ 0x30

Bit	7	6	5	4	3	2	1	0
Name						RUNNING	SUSPEND	SLEEP
Type				R			R	R

Reset value = 0000 0000

Bit	Name	Function
7:3	Reserved	Reserved
2	RUNNING	Device is awake.
1	SUSPEND	Device is in a low-power state, waiting for a measurement to complete.
0	SLEEP	Device is in its lowest power state.

ANA_IN_KEY @ 0x3B to 0x3E

Bit	7	6	5	4	3	2	1	0
0x3B	ANA_IN_KEY[31:24]							
0x3C	ANA_IN_KEY[23:16]							
0x3D	ANA_IN_KEY[15:8]							
0x3E	ANA_IN_KEY[7:0]							
Type	RW							

Reset value = 0000 0000

Bit	Name	Function
31:0	ANA_IN_KEY[31:0]	Reserved.

Si1145/46/47-M01

4.6. Parameter RAM

Parameters are located in internal memory and are not directly addressable over I²C. They must be indirectly accessed using the PARAM_QUERY and PARAM_SET Commands that are described in Section “4.2 Command Protocol”.

Table 16. Parameter RAM Summary Table

Parameter Name	Offset	Bit 7	Bit 6	Bit 5	Bit 4	Bit 3	Bit 2	Bit 1	Bit 0	
I2C_ADDR	0x00	I ² C Address								
CHLIST	0x01	EN_UV	EN_AUX	EN_ALS_IR	EN_ALS_VIS	—	EN_PS3	EN_PS2	EN_PS1	
PSLED12_SELECT	0x02	—	PS2_LED			—	PS1_LED			
PSLED3_SELECT	0x03	—					PS3_LED			
Reserved	0x04	Reserved (always set to 0)								
PS_ENCODING	0x05	—	PS3_ALIGN	PS2_ALIGN	PS1_ALIGN	Reserved (always set to 0)				
ALS_ENCODING	0x06	—		ALS_IR_ALIGN	ALS_VIS_ALIGN	Reserved (always set to 0)				
PS1_ADCMUX	0x07	PS1 ADC Input Selection								
PS2_ADCMUX	0x08	PS2 ADC Input Selection								
PS3_ADCMUX	0x09	PS3 ADC Input Selection								
PS_ADC_COUNTER	0x0A	—	PS_ADC_REC			Reserved (always set to 0)				
PS_ADC_GAIN	0x0B	—					PS_ADC_GAIN			
PS_ADC_MISC	0x0C	—		PS_RANGE	—		PS_ADC_MODE	—		
Reserved	0x0D	Reserved (do not modify from default setting of 0x02)								
ALS_IR_ADCMUX	0x0E	ALS_IR_ADCMUX								
AUX_ADCMUX	0x0F	AUX ADC Input Selection								
ALS_VIS_ADC_COUNTER	0x10	—	VIS_ADC_REC			Reserved (always set to 0)				
ALS_VIS_ADC_GAIN	0x11	—					ALS_VIS_ADC_GAIN			
ALS_VIS_ADC_MISC	0x12	Reserved (always set to 0)		VIS_RANGE	Reserved (always set to 0)					
Reserved	0x13	Reserved (do not modify from default setting of 0x40)								
Reserved	0x14–0x15	Reserved (do not modify from default setting of 0x00)								
Reserved	0x16–0x1A	Reserved								
Reserved	0x1B	Reserved (do not modify from default setting of 0x00)								

Table 16. Parameter RAM Summary Table (Continued)

Parameter Name	Offset	Bit 7	Bit 6	Bit 5	Bit 4	Bit 3	Bit 2	Bit 1	Bit 0	
LED_REC	0x1C	LED recovery time								
ALS_IR_ADC_COUNTER	0x1D	—	IR_ADC_REC			Reserved (always set to 0)				
ALS_IR_ADC_GAIN	0x1E						ALS_IR_ADC_GAIN			
ALS_IR_ADC_MISC	0x1F	Reserved (always set to 0)		IR_RANGE	Reserved (always set to 0)					

I2C @ 0x00

Bit	7	6	5	4	3	2	1	0
Name	I ² C Address[7:0]							
Type	RW							

Reset value = 0000 0000

Bit	Name	Function
7:0	I ² C Address[7:0]	Specifies a new I ² C Address for the device to respond to. The new address takes effect when a BUSADDR command is received.

Si1145/46/47-M01

CHLIST @ 0x01

Bit	7	6	5	4	3	2	1	0
Name	EN_UV	EN_AUX	EN_ALS_IR	EN_ALS_VIS		EN_PS3	EN_PS2	EN_PS1
Type	RW				RW			

Reset value = 0000 0000

Bit	Name	Function
7	EN_UV	Enables UV Index, data stored in AUX_DATA1 [7:0] and AUX_DATA0 [7:0]
6	EN_AUX	Enables Auxiliary Channel, data stored in AUX_DATA1[7:0] and AUX_DATA0[7:0].
5	EN_ALS_IR	Enables ALS IR Channel, data stored in ALS_IR_DATA1[7:0] and ALS_IR_DATA0[7:0].
4	EN_ALS_VIS	Enables ALS Visible Channel, data stored in ALS_VIS_DATA1[7:0] and ALS_VIS_DATA0[7:0].
3	Reserved	
2	EN_PS3	Enables PS Channel 3, data stored in PS3_DATA1[7:0] and PS3_DATA0[7:0].
1	EN_PS2	Enables PS Channel 2, data stored in PS2_DATA1[7:0] and PS2_DATA0[7:0].
0	EN_PS1	Enables PS Channel 1, data stored in PS1_DATA1[7:0] and PS1_DATA0[7:0].

Note: For proper operation, CHLIST must be written with a non-zero value before forced measurements or autonomous operation is requested.

PSLED12_SELECT @ 0x02

Bit	7	6	5	4	3	2	1	0
Name		PS2_LED[2:0]				PS1_LED[2:0]		
Type		RW				RW		

Reset value = 0010 0001

Bit	Name	Function
7	Reserved	
6:4	PS2_LED[2:0]	Specifies the LED pin driven during the PS2 Measurement. Note that any combination of irLEDs is possible. 000: NO LED DRIVE xx1: LED1 Drive Enabled x1x: LED2 Drive Enabled (Si1146 and Si1147 only. Clear for Si1145.) 1xx: LED3 Drive Enabled (Si1147 only. Clear for Si1145 and Si1146.)
3	Reserved	
2:0	PS1_LED[2:0]	Specifies the LED pin driven during the PS1 Measurement. Note that any combination of irLEDs is possible. 000: NO LED DRIVE xx1: LED1 Drive Enabled x1x: LED2 Drive Enabled (Si1146 and Si1147 only. Clear for Si1145.) 1xx: LED3 Drive Enabled (Si1147 only. Clear for Si1145 and Si1146.)

PSLED3_SELECT @ 0x03

Bit	7	6	5	4	3	2	1	0
Name						PS3_LED[2:0]		
Type						RW		

Reset value = 0000 0100

Bit	Name	Function
7:3	Reserved	
2:0	PS3_LED[2:0]	Specifies the LED pin driven during the PS3 Measurement. Note that any combination of irLEDs is possible. 000: No LED drive. xx1: LED1 drive enabled. x1x: LED2 drive enabled. (Si1146 and Si1147 only. Clear for Si1145.) 1xx: LED3 drive enabled. (Si1147 only. Clear for Si1145 and Si1146.)

Si1145/46/47-M01

PS_ENCODING @ 0x05

Bit	7	6	5	4	3	2	1	0
Name		PS3_ALIGN	PS2_ALIGN	PS1_ALIGN				
Type		RW	R/W	R/W				

Reset value = 0000 0000

Bit	Name	Function
7	Reserved	
6	PS3_ALIGN	When set, the ADC reports the least significant 16 bits of the 17-bit ADC when performing PS3 Measurement. Reports the 16 MSBs when cleared.
5	PS2_ALIGN	When set, the ADC reports the least significant 16 bits of the 17-bit ADC when performing PS2 Measurement. Reports the 16 MSBs when cleared.
4	PS1_ALIGN	When set, the ADC reports the least significant 16 bits of the 17-bit ADC when performing PS1 Measurement. Reports the 16 MSBs when cleared.
3:0	Reserved	Always set to 0.

ALS_ENCODING @ 0x06

Bit	7	6	5	4	3	2	1	0
Name			ALS_IR_ALIGN	ALS_VIS_ALIGN				
Type			RW	RW				

Reset value = 0000 0000

Bit	Name	Function
7:6	Reserved	
5	ALS_IR_ALIGN	When set, the ADC reports the least significant 16 bits of the 17-bit ADC when performing ALS VIS Measurement. Reports the 16 MSBs when cleared.
4	ALS_VIS_ALIGN	When set, the ADC reports the least significant 16 bits of the 17-bit ADC when performing ALS IR Measurement. Reports the 16 MSBs when cleared.
3:0	Reserved	Always set to 0.

PS1_ADCMUX @ 0x07

Bit	7	6	5	4	3	2	1	0
Name	PS1_ADCMUX[7:0]							
Type	RW							

Reset value = 0000 0011

Bit	Name	Function
7:0	PS1_ADCMUX[7:0]	<p>Selects ADC Input for PS1 Measurement.</p> <p>The following selections are valid when PS_ADC_MODE = 1 (default). This setting is for normal Proximity Detection function.</p> <p>0x03: Large IR Photodiode 0x00: Small IR Photodiode</p> <p>In addition, the following selections are valid for PS_ADC_MODE = 0. With this setting, irLED drives are disabled and the PS channels are no longer operating in normal Proximity Detection function. The results have no reference and the references needs to be measured in a separate measurement.</p> <p>0x02: Visible Photodiode A separate 'No Photodiode' measurement should be subtracted from this reading. Note that the result is a negative value. The result should therefore be negated to arrive at the Ambient Visible Light reading.</p> <p>0x03: Large IR Photodiode A separate "No Photodiode" measurement should be subtracted to arrive at Ambient IR reading.</p> <p>0x00: Small IR Photodiode A separate "No Photodiode" measurement should be subtracted to arrive at Ambient IR reading.</p> <p>0x06: No Photodiode This is typically used as reference for reading ambient IR or visible light.</p> <p>0x25: GND voltage This is typically used as the reference for electrical measurements.</p> <p>0x65: Temperature (Should be used only for relative temperature measurement. Absolute Temperature not guaranteed) A separate GND measurement should be subtracted from this reading.</p> <p>0x75: V_{DD} voltage A separate GND measurement is needed to make the measurement meaningful.</p>

Si1145/46/47-M01

PS2_ADCMUX @ 0x08

Bit	7	6	5	4	3	2	1	0
Name	PS2_ADCMUX[7:0]							
Type	R/W							

Reset value = 0000 0011

Bit	Name	Function
7:0	PS2_ADCMUX[7:0]	Selects input for PS2 measurement. See PS1_ADCMUX register description for details.

PS3_ADCMUX @ 0x09

Bit	7	6	5	4	3	2	1	0
Name	PS3_ADCMUX[7:0]							
Type	R/W							

Reset value = 0000 0011

Bit	Name	Function
7:0	PS3_ADCMUX[7:0]	Selects input for PS3 measurement. See PS1_ADCMUX register description for details.

PS_ADC_COUNTER @ 0x0A

Bit	7	6	5	4	3	2	1	0
Name		PS_ADC_REC[2:0]						
Type		RW	R/W	R/W				

Reset value = 0111 0000

Bit	Name	Function
7	Reserved	
6:4	PS_ADC_REC[2:0]	<p>Recovery period the ADC takes before making a PS measurement.</p> <p>000: 1 ADC Clock (50 ns times $2^{\text{PS_ADC_GAIN}}$)</p> <p>001: 7 ADC Clock (350 ns times $2^{\text{PS_ADC_GAIN}}$)</p> <p>010: 15 ADC Clock (750 ns times $2^{\text{PS_ADC_GAIN}}$)</p> <p>011: 31 ADC Clock (1.55 μs times $2^{\text{PS_ADC_GAIN}}$)</p> <p>100: 63 ADC Clock (3.15 μs times $2^{\text{PS_ADC_GAIN}}$)</p> <p>101: 127 ADC Clock (6.35 μs times $2^{\text{PS_ADC_GAIN}}$)</p> <p>110: 255 ADC Clock (12.75 μs times $2^{\text{PS_ADC_GAIN}}$)</p> <p>111: 511 ADC Clock (25.55 μs times $2^{\text{PS_ADC_GAIN}}$)</p> <p>The recommended PS_ADC_REC value is the one's complement of PS_ADC_GAIN.</p>
3:0	Reserved	Always set to 0.

Si1145/46/47-M01

PS_ADC_GAIN @ 0x0B

Bit	7	6	5	4	3	2	1	0
Name						PS_ADC_GAIN[2:0]		
Type						R/W	R/W	R/W

Reset value = 0000 0000

Bit	Name	Function
7:3	Reserved	
2:0	PS_ADC_GAIN[2:0]	<p>Increases the irLED pulse width and ADC integration time by a factor of $(2 ^ PS_ADC_GAIN)$ for all PS measurements.</p> <p>Care must be taken when using this feature. At an extreme case, each of the three PS measurements can be configured to drive three separate irLEDs, each of which, are configured for 359 mA. The internal sequencer does not protect the device from such an error. To prevent permanent damage to the device, do not enter any value greater than 5 without consulting with Silicon Labs.</p> <p>For Example:</p> <p>0x0: ADC Clock is divided by 1 0x4: ADC Clock is divided by 16 0x5: ADC Clock is divided by 32</p>

PS_ADC_MISC @ 0x0C

Bit	7	6	5	4	3	2	1	0
Name			PS_RANGE			PS_ADC_MODE		
Type	RW				RW			

Reset value = 0000 0100

Bit	Name	Function
7:6	Reserved	
5	PS_RANGE	When performing PS measurements, the ADC can be programmed to operate in high sensitivity operation or high signal range. The high signal range is useful in operation under direct sunlight. 0: Normal Signal Range 1: High Signal Range (Gain divided by 14.5)
4:3	Reserved	
2	PS_ADC_MODE	PS Channels can either operate normally as PS channels, or it can be used to perform raw ADC measurements: 0: Raw ADC Measurement Mode 1: Normal Proximity Measurement Mode
1:0	Reserved	

ALS_IR_ADCMUX @ 0x0E

Bit	7	6	5	4	3	2	1	0
Name	ALS_IR_ADCMUX							
Type	RW							

Reset value = 0000 0000

Bit	Name	Function
7:0	ALS_IR_ADCMUX	Selects ADC Input for ALS_IR Measurement. 0x00: Small IR photodiode 0x03: Large IR photodiode

Si1145/46/47-M01

AUX_ADCMUX @ 0x0F

Bit	7	6	5	4	3	2	1	0
Name	AUX_ADCMUX[7:0]							
Type	RW							

Reset value = 0110 0101

Bit	Name	Function
7:0	AUX_ADCMUX[7:0]	Selects input for AUX Measurement. These measurements are referenced to GND. 0x65: Temperature (Should be used only for relative temperature measurement. Absolute Temperature not guaranteed) 0x75: V _{DD} voltage

ALS_VIS_ADC_COUNTER @ 0x10

Bit	7	6	5	4	3	2	1	0
Name	VIS_ADC_REC[2:0]							
Type	RW		R/W	R/W				

Reset value = 0111 0000

Bit	Name	Function
7	Reserved	
6:4	VIS_ADC_REC[2:0]	Recovery period the ADC takes before making a ALS-VIS measurement. 000: 1 ADC Clock (50 ns times $2^{\text{ALS_VIS_ADC_GAIN}}$) 001: 7 ADC Clock (350 ns times $2^{\text{ALS_VIS_ADC_GAIN}}$) 010: 15 ADC Clock (750 ns times $2^{\text{ALS_VIS_ADC_GAIN}}$) 011: 31 ADC Clock (1.55 μ s times $2^{\text{ALS_VIS_ADC_GAIN}}$) 100: 63 ADC Clock (3.15 μ s times $2^{\text{ALS_VIS_ADC_GAIN}}$) 101: 127 ADC Clock (6.35 μ s times $2^{\text{ALS_VIS_ADC_GAIN}}$) 110: 255 ADC Clock (12.75 μ s times $2^{\text{ALS_VIS_ADC_GAIN}}$) 111: 511 ADC Clock (25.55 μ s times $2^{\text{ALS_VIS_ADC_GAIN}}$) The recommended VIS_ADC_REC value is the one's complement of ALS_VIS_ADC_GAIN.
3:0	Reserved	Always set to 0.

Note: For A02 and earlier, this parameter also controls ALS-IR measurements.

ALS_VIS_ADC_GAIN @ 0x11

Bit	7	6	5	4	3	2	1	0
Name						ALS_VIS_ADC_GAIN[2:0]		
Type						RW	R/W	RW

Reset value = 0000 0000

Bit	Name	Function
7:3	Reserved	
2:0	ALS_VIS_ADC_GAIN[2:0]	Increases the ADC integration time for ALS Visible measurements by a factor of $(2^{\text{ALS_VIS_ADC_GAIN}})$. This allows visible light measurement under dark glass. The maximum gain is 128 (0x7). For Example: 0x0: ADC Clock is divided by 1 0x4: ADC Clock is divided by 16 0x6: ADC Clock is divided by 64
Note: For A02 and earlier, this parameter also controls ALS-IR measurements.		

ALS_VIS_ADC_MISC @ 0x12

Bit	7	6	5	4	3	2	1	0
Name			VIS_RANGE					
Type			RW					

Reset value = 0000 0000

Bit	Name	Function
7:6	Reserved	
5	VIS_RANGE	When performing ALS-VIS measurements, the ADC can be programmed to operate in high sensitivity operation or high signal range. The high signal range is useful in operation under direct sunlight. 0: Normal Signal Range 1: High Signal Range (Gain divided by 14.5)
4:0	Reserved	
Note: For A02 and earlier, this parameter also controls ALS-IR measurements.		

Si1145/46/47-M01

LED_REC @ 0x1C

Bit	7	6	5	4	3	2	1	0
Name	LED_REC[7:0]							
Type	RW							

Reset value = 0000 0000

Bit	Name	Function
7:0	LED_REC[7:0]	Reserved.

ALS_IR_ADC_COUNTER @ 0x1D

Bit	7	6	5	4	3	2	1	0
Name	IR_ADC_REC[2:0]							
Type	RW							

Reset value = 0111 0000

Bit	Name	Function
7	Reserved	
6:4	IR_ADC_REC[2:0]	Recovery period the ADC takes before making a ALS-IR measurement. 000: 1 ADC Clock (50 ns times $2^{\text{ALS_IR_ADC_GAIN}}$) 001: 7 ADC Clock (350 ns times $2^{\text{ALS_IR_ADC_GAIN}}$) 010: 15 ADC Clock (750 ns times $2^{\text{ALS_IR_ADC_GAIN}}$) 011: 31 ADC Clock (1.55 μ s times $2^{\text{ALS_IR_ADC_GAIN}}$) 100: 63 ADC Clock (3.15 μ s times $2^{\text{ALS_IR_ADC_GAIN}}$) 101: 127 ADC Clock (6.35 μ s times $2^{\text{ALS_IR_ADC_GAIN}}$) 110: 255 ADC Clock (12.75 μ s times $2^{\text{ALS_IR_ADC_GAIN}}$) 111: 511 ADC Clock (25.55 μ s times $2^{\text{ALS_IR_ADC_GAIN}}$) The recommended IR_ADC_REC value is the one's complement of ALS_IR_ADC_GAIN.
3:0	Reserved	Always set to 0.

Note: This parameter available for sequencer revisions A03 or later.

ALS_IR_ADC_GAIN @ 0x1E

Bit	7	6	5	4	3	2	1	0
Name						ALS_IR_ADC_GAIN[2:0]		
Type						R/W	R/W	R/W

Reset value = 0000 0000

Bit	Name	Function
7:3	Reserved	
2:0	ALS_IR_ADC_GAIN[2:0]	Increases the ADC integration time for IR Ambient measurements by a factor of $(2 ^ \text{ALS_IR_ADC_GAIN})$. The maximum gain is 128 (0x7). For Example: 0x0: ADC Clock is divided by 1 0x4: ADC Clock is divided by 16 0x6: ADC Clock is divided by 64
Note: This parameter available for sequencer revisions A03 or later.		

ALS_IR_ADC_MISC @ 0x1F

Bit	7	6	5	4	3	2	1	0
Name			IR_RANGE					
Type			RW					

Reset value = 0000 0000

Bit	Name	Function
7:6	Reserved	
5	IR_RANGE	When performing ALS-IR measurements, the ADC can be programmed to operate in high sensitivity operation or high signal range. The high signal range is useful in operation under direct sunlight. 0: Normal Signal Range 1: High Signal Range (Gain divided by 14.5)
4:0	Reserved	Write operations to this RAM parameter must preserve this bit-field value using read-modify-write.
Note: This parameter is available for sequencer revisions A03 or later.		

Si1145/46/47-M01

5. Pin Descriptions

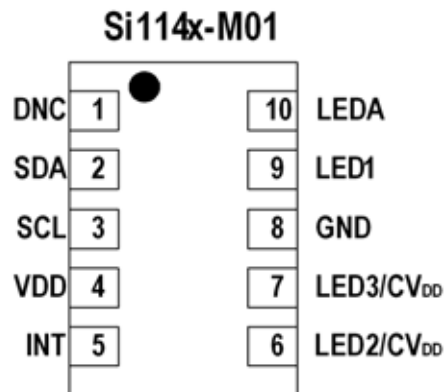

Table 17. Pin Descriptions

Pin	Name	Type	Description
1	DNC		Do Not Connect. This pin is electrically connected to an internal Si1145/46/47-M01 node. It should remain unconnected.
2	SDA	Bidirectional	I ² C Data.
3	SCL	Input	I ² C Clock.
4	VDD	Power	Power Supply. Voltage source.
5	INT	Bidirectional	Interrupt Output. Open-drain interrupt output pin. Must be at logic level high during power-up sequence to enable low power operation.
6	LED2/ CV _{DD} ¹	Output	LED2 Output/Connect to V _{DD} ¹ Programmable constant current sink normally connected to an infrared LED cathode. Connect directly to V _{DD} when not in use.
7	LED3/ CV _{DD} ²	Output	LED3 Output/Connect to V _{DD} ² Programmable constant current sink normally connected to an infrared LED cathode. If V _{LED} < (V _{DD} + 0.5 V), a 47 kΩ pull-up resistor from LED3 to V _{DD} is needed for proper operation. Connect directly to V _{DD} when not in use.
8	GND	Power	Ground. Reference voltage.
9	LED1	Output	LED1 Output. Programmable constant current sink connected to the internal LED cathode. For long-range proximity detection, connect LED1 to LED2 and LED3.
10	LEDA	Input	Internal LED anode. Connect to external resistor and capacitor.

Notes:

1. Si1145 and Si1146 only. Must connect to V_{DD} in Si1145.
2. Si1147 only. Must connect to V_{DD} in Si1145 and Si1146.

6. Ordering Guide

Part Number	Package	LED Drivers/Integrated LEDs
Si1147-M01-GMR	4.9 x 2.85 x 1.2 mm QFN	3 LED drivers, 1 LED Integrated
Si1146-M01-GMR	4.9 x 2.85 x 1.2 mm QFN	2 LED drivers, 1 LED Integrated
Si1145-M01-GMR	4.9 x 2.85 x 1.2 mm QFN	1 LED driver, 1 LED Integrated

Si1145/46/47-M01

7. Package Outline: 10-Pin QFN

Figure 24 illustrates the package details for the Si1145/46/47-M01 Si1145/46/47-M01 QFN package. Table 19 lists the values for the dimensions shown in the illustration.

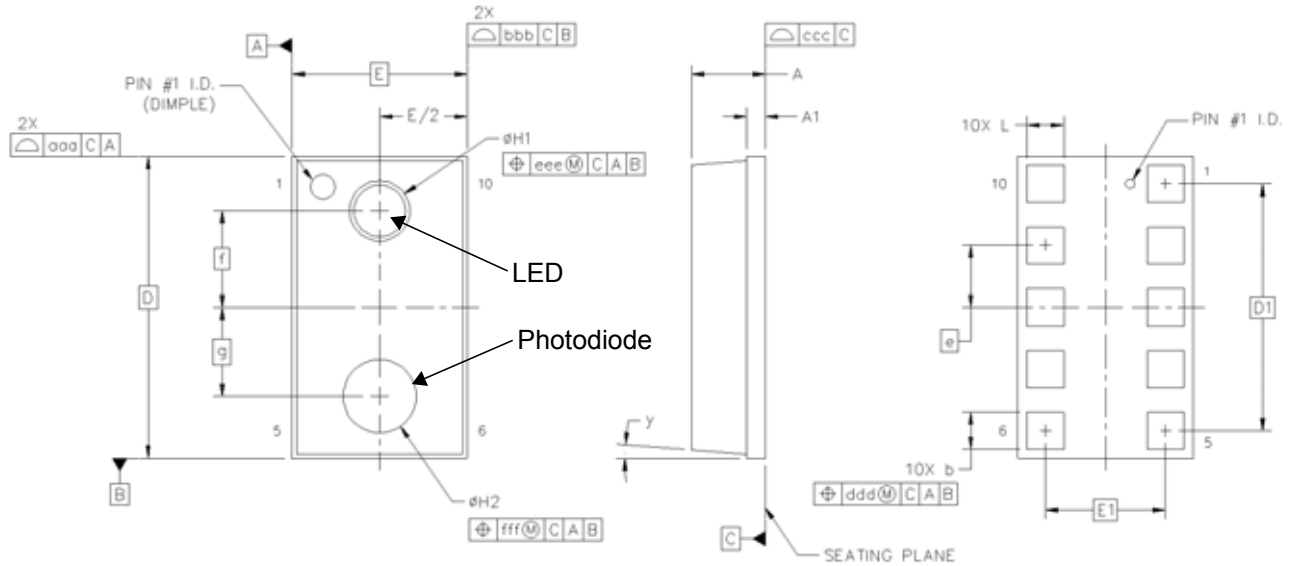

Figure 24. QFN Package Diagram Dimensions

Table 18. QFN Package Diagram Dimensions

Dimension	Min	Nom	Max
A	1.10	1.20	1.30
A1	0.28	0.30	0.32
b	0.55	0.60	0.65
D	4.90 BSC		
D1	4.00 BSC		
e	1.00 BSC		
E	2.85 BSC		
E1	1.95 BSC		
f	1.56 BSC		
g	1.44 BSC		
H1	0.98	1.03	1.08
H2	1.19	1.24	1.29
L	0.55	0.60	0.65
y	3° REF		
aaa	0.10		
bbb	0.10		
ccc	0.08		
ddd	0.10		
eee	0.10		
fff	0.10		
Notes:			
1. All dimensions shown are in millimeters (mm) unless otherwise noted.			
2. Dimensioning and tolerancing per ANSI Y14.5M-1994.			
3. Recommended card reflow profile is per the JEDEC/IPC J-STD-020 specification for Small Body Components.			

8. Suggested PCB Land Pattern

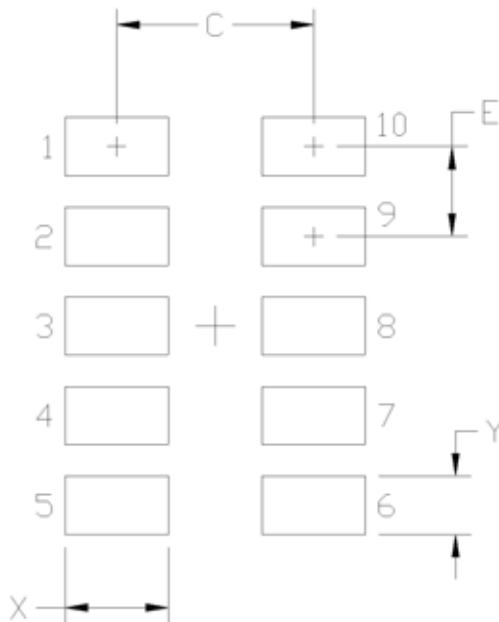

Table 19. PCB Land Pattern Dimensions

Dimension	mm
C	2.20
E	1.00
X	1.15
Y	0.65

Notes:

General

1. All dimensions shown are in millimeters (mm).
2. This Land Pattern Design is based on the IPC-7351 guidelines.
3. All dimensions shown are at Maximum Material Condition (MMC). Least Material Condition (LMC) is calculated based on a Fabrication Allowance of 0.05 mm.

Solder Mask Design

4. All metal pads are to be non-solder mask defined (NSMD). Clearance between the solder mask and the metal pad is to be 60 μm minimum, all the way around the pad.

Stencil Design

5. A stainless steel, laser-cut and electro-polished stencil with trapezoidal walls should be used to assure good solder paste release.
6. The stencil thickness should be 0.125 mm (5 mils).
7. The ratio of stencil aperture to land pad size should be 1:1 for all pads.

Card Assembly

8. A No-Clean, Type-3 solder paste is recommended.
9. The recommended card reflow profile is per the JEDEC/IPC J-STD-020 specification for Small Body Components.

9. Top Markings

9.1. Si1145-M01-GMR Top Marking

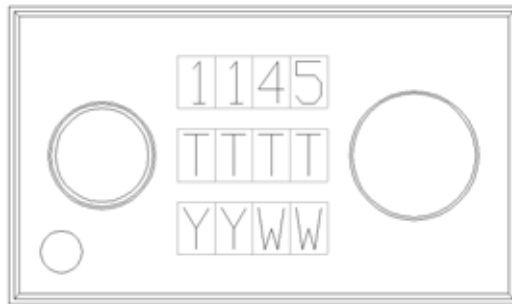

Figure 25. Si1145-M01-GMR Top Marking

9.2. Si1146-M01-GMR Top Marking

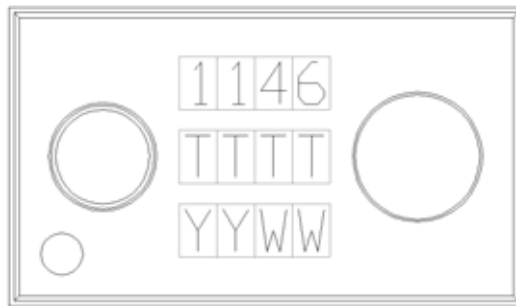

Figure 26. Si1146-M01-GMR Top Marking

9.3. Si1147-M01-GMR Top Marking

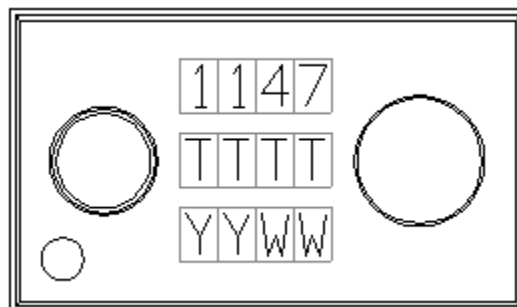

Figure 27. Si1147-M01-GMR Top Marking

Si1145/46/47-M01

9.4. Top Marking Explanation

Mark Method	YAG Laser	
Line 1 Marking	Part Number	
Line 2 Marking	TTTT=Trace Code	Assigned by the Assembly House. Corresponds to the year and work week of the mold date. Product version and Site.
Line 3 Marking	YY = Current Year WW = Work Week	Lot Number assigned by the Assembly Site
Line 4 Marking	Circle = 0.7 mm Diameter Lower Left-Justified	Pin 1 Identifier

DOCUMENT CHANGE LIST

Revision 0.2 to Revision 0.3

- Updated recommended UV coefficients.

Revision 0.3 to Revision 1.0

- Clarified usage of Command Register and Parameter RAM.
- Clarified LED2 and LED3 connection when using Si1145 and Si1146.

CONTACT INFORMATION

Silicon Laboratories Inc.

400 West Cesar Chavez
Austin, TX 78701
Tel: 1+(512) 416-8500
Fax: 1+(512) 416-9669
Toll Free: 1+(877) 444-3032

Please visit the Silicon Labs Technical Support web page:
<https://www.silabs.com/support/pages/contacttechnicalsupport.aspx>
and register to submit a technical support request.

Patent Notice

Silicon Labs invests in research and development to help our customers differentiate in the market with innovative low-power, small size, analog-intensive mixed-signal solutions. Silicon Labs' extensive patent portfolio is a testament to our unique approach and world-class engineering team.

The information in this document is believed to be accurate in all respects at the time of publication but is subject to change without notice. Silicon Laboratories assumes no responsibility for errors and omissions, and disclaims responsibility for any consequences resulting from the use of information included herein. Additionally, Silicon Laboratories assumes no responsibility for the functioning of undescribed features or parameters. Silicon Laboratories reserves the right to make changes without further notice. Silicon Laboratories makes no warranty, representation or guarantee regarding the suitability of its products for any particular purpose, nor does Silicon Laboratories assume any liability arising out of the application or use of any product or circuit, and specifically disclaims any and all liability, including without limitation consequential or incidental damages. Silicon Laboratories products are not designed, intended, or authorized for use in applications intended to support or sustain life, or for any other application in which the failure of the Silicon Laboratories product could create a situation where personal injury or death may occur. Should Buyer purchase or use Silicon Laboratories products for any such unintended or unauthorized application, Buyer shall indemnify and hold Silicon Laboratories harmless against all claims and damages.

Silicon Laboratories and Silicon Labs are trademarks of Silicon Laboratories Inc.
Other products or brandnames mentioned herein are trademarks or registered trademarks of their respective holders.