

BAROMETER MODULE

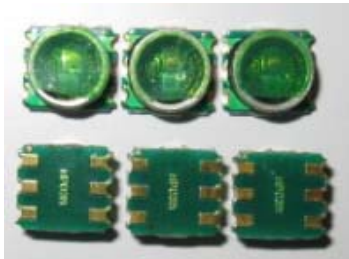

- . Integrated pressure sensor
- . Pressure Range 750-1100hpa
- . 16 Bit Σ - Δ ADC
- . I²C Serial Interface
- . One system clock line (32768Hz)
- . Low voltage, low power

Description

The HP01 pressure module includes a piezo-resistive pressure sensor and an ADC interface. It provides 16 bit word data for pressure and temperature related voltage. HP01 is a low power, low voltage device with automatic power down switching. I²C Serial Interface is used for communications with a microprocessor.

Features

- . 14 Bit ENOB ADC resolution
- . Supply voltage 2.2-3.6v
- . -40°C to + 85°C operating range

Applications

- . Pressure measurement and control systems
- . Weather forecast products

Block Diagram

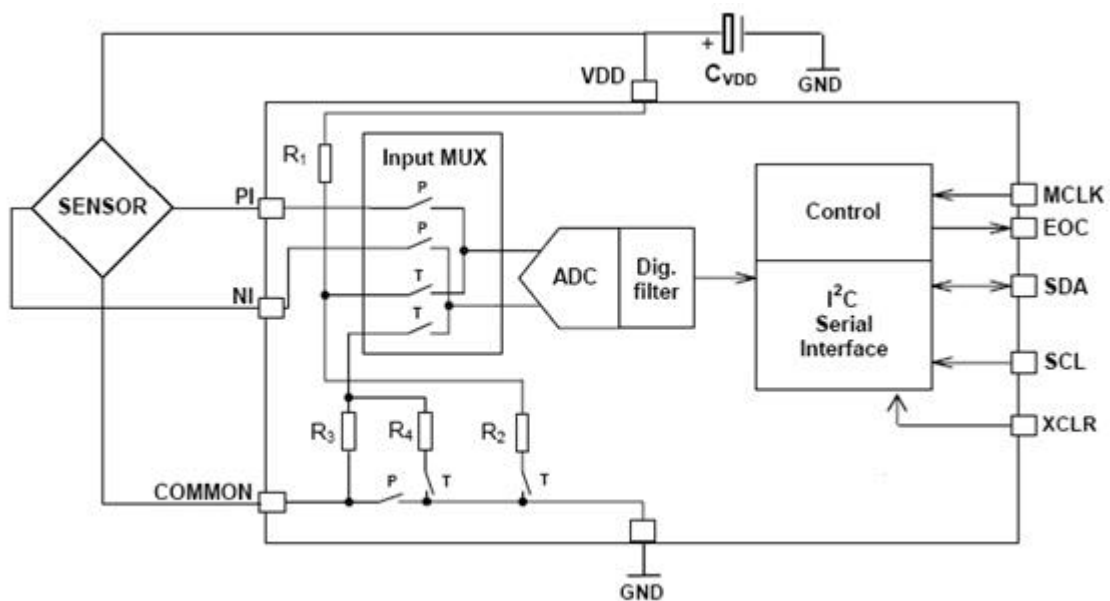

BAROMETER MODULE

2011-4-20

PRELIMINARY

Version: 2.2

Pin Name	Pin Number	Type	Function
VSS	1	G	power ground
VDD	2	P	power VCC
MCLK	3	I	master clock(32k) input
XCLR*	4	I	ADC reset input
SDA	5	I/O	I ² C data input and output
SCL	6	I	I ² C clock input

* XCLR is to reset the AD converter (active low). During the AD conversion phase, XCLR should stay high. After AD conversion end, keep XCLR pin low before another AD conversion starts.

Absolute Maximum Ratings

Parameter	Symbol	Min	Max	Unit
Supply Voltage	VDD	-0.3	4.0	V
Over pressure	P		5	Bar(abs)
Storage Temperature	Tstg	-40	125	°C

Recommended Operating Conditions

Parameter	Symbol	Conditions	Min	Typ	Max	Unit
Supply Voltage	VDD		2.2	3	3.6	V
Supply Current	I	VDD=3V				V
During conversion				500		μA
Stand by				1		μA
Operating Pressure Range	P		900		1100	Hpa (abs)
Operating Temperature Range	T		-40	25	85	°C
Conversion Time	T	MCLK=32k			35	ms
Duty Cycle of MCLK			40%	50%	60%	%
Serial Date Rate	SCL				100	KHZ

Pressure and Temperature Output Characteristics

HP01 system is able to reach the following characteristics:

Parameter	Symbol	Conditions	Min	Typ	Max	Unit
Resolution			0.1			hpa
Accuracy		900-1100	-8		+10	hpa
Pressure Sensitivity	SNS	900-1100	25	27	30	Cnts/mbar
Maximum Error Over Temperature		0~+55	-5.0		5.0	hpa
Long Term Stability		12 month		1		hpa
VDD Dependency		2.0~5.0	-1.5	0	1.5	hpa
Temperature coefficient of sensitivity	TCS		-0.45	-0.55	-0.6	ΔD1/ΔD2

BAROMETER MODULE

2011-4-20

PRELIMINARY

Version: 2.2

Pressure Measurement

The main function of HP01 system is to convert the uncompensated pressure and temperature signal from a pressure sensor. After the conversion, the following two values can be obtained:

- . measured temperature “D2”
- . measured pressure “D1”

As the sensor is strongly temperature dependent, it is necessary to compensate for these effects. Therefore necessary temperature compensation is needed to achieve nominal accuracy.

Pressure and Temperature Compensation Calculation:

The following information is just a guide line for temperature compensate, the end user of this module should not be confined to this method. Many other methods can be deployed to achieve best accuracy.

Step 1: (set relative pressure starting reference point, normally this step be done after power up or reset relative pressure)

$$\begin{aligned} P0 &= 1013.2 \text{hp} \\ D1(P0) &= D1 \\ D2(P0) &= D2 \end{aligned}$$

Step 2: (normal pressure calculation with first order temperature compensation)

$$\begin{aligned} dUT &= D2 - D2(P0) && ; \text{ calculate current temperature difference with reference temperature} \\ dTCS &= TCS * dUT && ; \text{ calculate compensated pressure offset with temperature coefficients} \\ dUP &= D1 - dTCS - D1(P0) && ; \text{ calculate temperature compensated pressure reading} \\ P2 &= dUP / SNS && ; \text{ calculate pressure difference referred to starting pressure } P0 \\ P &= P0 + P2 && ; \text{ calculate current relative pressure} \end{aligned}$$

Example:

$$\begin{aligned} D1(P0) &= 30000 && (\text{obtained after power up reading: } D1) \\ D2(P0) &= 4100 && (\text{obtained after power up reading: } D2) \\ TCS &= -0.55 && (\text{nominal module value from this data sheet}) \\ SNS &= 27 && (\text{nominal module value from this data sheet}) \end{aligned}$$

$$\begin{aligned} D1 &= 30036 && (\text{current pressure AD reading from module}) \\ D2 &= 4107 && (\text{current temperature AD reading from module}) \end{aligned}$$

$$\begin{aligned} dUT &= 4107 - 4100 = 7 \\ dTCS &= -0.55 * 7 = -3.85 \\ dUP &= 30036 + 3.85 - 30000 = 39 \end{aligned}$$

BAROMETER MODULE

2011-4-20

PRELIMINARY

Version: 2.2

$$P2=39/27=1.44$$

$$P=1013.2+1.44=1014.6$$

Serial Interface

The I²C interface is used for reading measurement result from AD conversion:D1 and D2.

Reading Temperature and Pressure value:D1,D2

AD chip I²C address is set to 0xEE (device write address), 0xEF (device read address). In order to get the AD value D1 and D2, you have to follow the following timing sequence:

Pressure Measure:

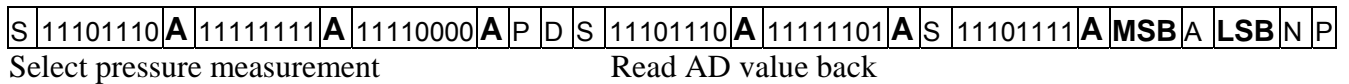

Temperature Measure:

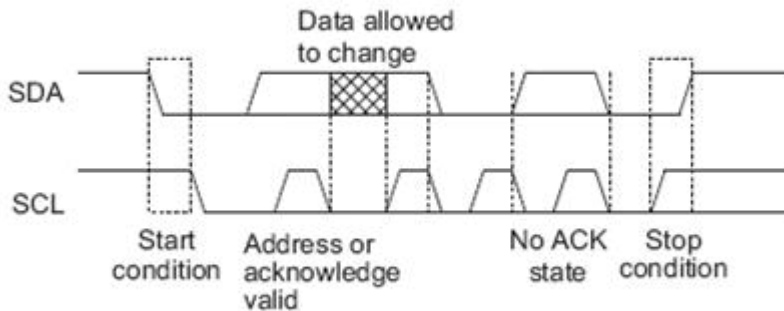
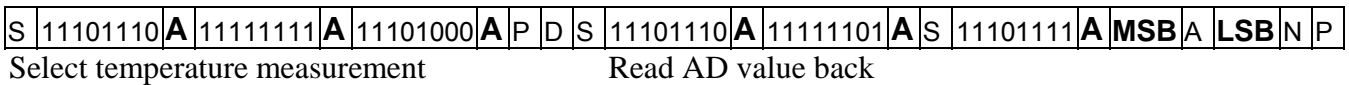

- S: I²C bus START (refer to AT24C02 EEPROM start command)
- P: I²C bus STOP (refer to AT24C02 EEPROM stop command)
- A** (bold): I²C bus acknowledge by slave (SDA pull low: slave send out bit 0)
- A: I²C bus acknowledge by master (SDA pull low: master send out bit 0)
- N: I²C bus no acknowledge from master (SDA keep high: master send out bit 1 instead)
- D : delay for 38ms or above
- MSB: conversion result (MSB bit clocked out first)
- LSB: conversion result (MSB bit clocked out first).

Remark:

Before start an AD conversion cycle, remember to set XCLR pin high so that the system is no longer in the reset state (not valid for HP01).

BAROMETER MODULE

2011-4-20

PRELIMINARY

Version: 2.2

All data read from the module is in hex format.

After first power on, the first read data should be disregarded, and only the second value be used. This can assure that unstable reading after power on reset can be filtered out.

Like any other semiconductor device, the sensor is sensitive to light. During the application of this sensor, please keep the sensor in dark place to achieve best accuracy.

Since the module is not calibrated for sensitivity and temperature, thus only relative pressure can be calculated. If you need higher accuracy with temperature, please refer to our HP02 or HP03 series pressure module accordingly.

Typical Application Circuit Diagram:

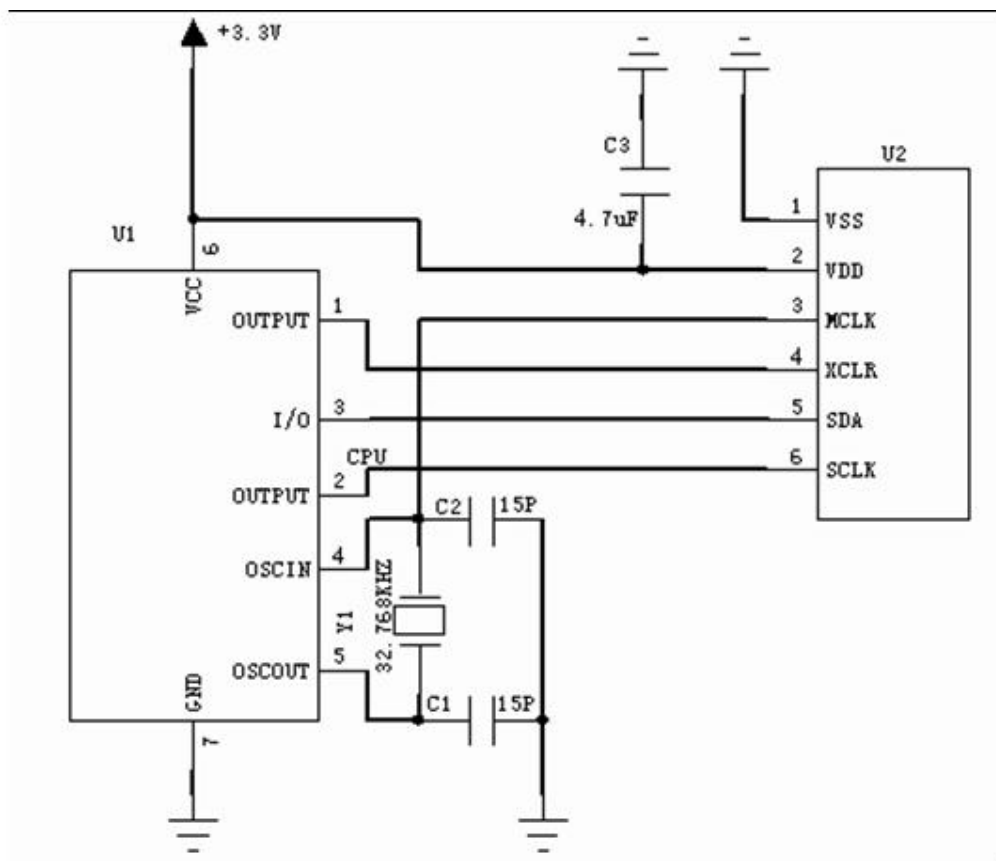

Remark:

In the battery supply product this application need be changed as:
 32 KHz signal is outputted via the port of the MCU instead of the 32.768 KHz crystal to MCLK pin. The MCU will not output 32 KHz signal and keep low level when the HP01 enter to standby mode.

BAROMETER MODULE

2011-4-20

PRELIMINARY

Version: 2.2

HP01-TQ Mechanical Dimension

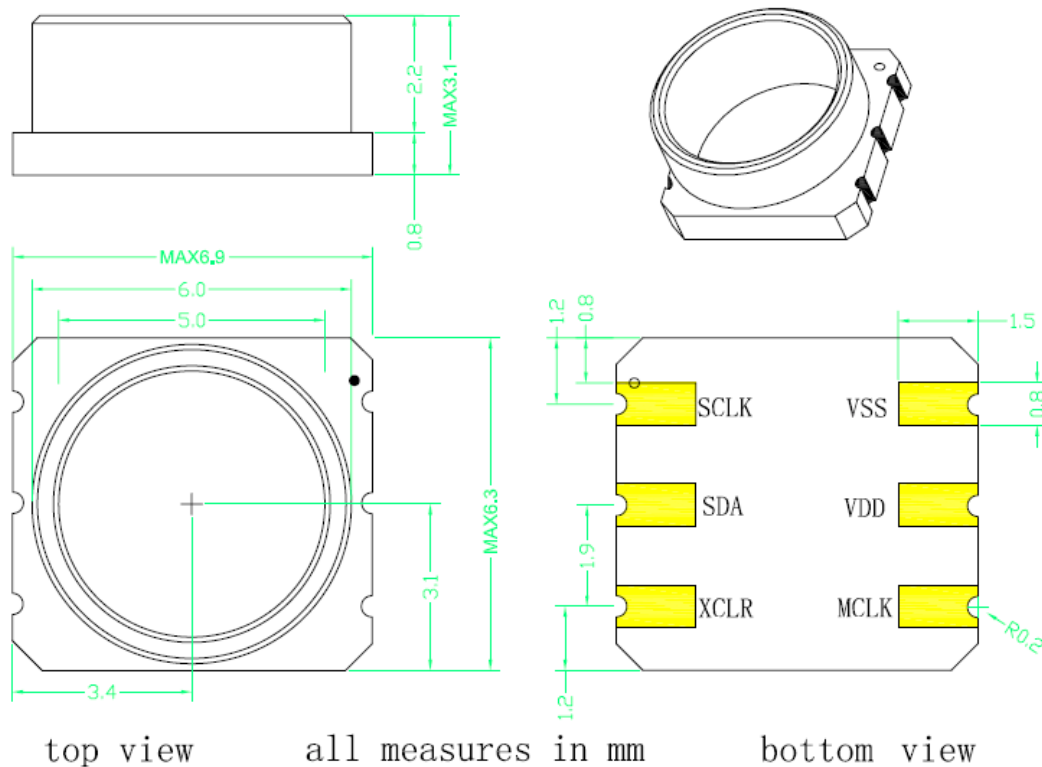

Never unplug the module when power is on.

Do not use this product as safety or emergency stop device or in any application where failure of this product could lead in personal injury. Failure to comply with these instructions could result with death or serious injury.

Should buyer purchase or use HOPE RF products for any such unintended or unauthorized application, buyer should indemnify and hold HOPE RF and its officers, employees, affiliates and distributors harmless against all claims, costs, damages and expenses, and reasonable attorney fees arising out of, directly or indirectly, any claim of personal injury associated with such unintended or unauthorized use, even if such claim alleges that HOPE RF was negligent regarding the design or manufacturing of the part.

Hope RF reserves the right, without further notice, to change the product specification and/or information in this document and to improve reliability, functions and design.