

MP8P8C R

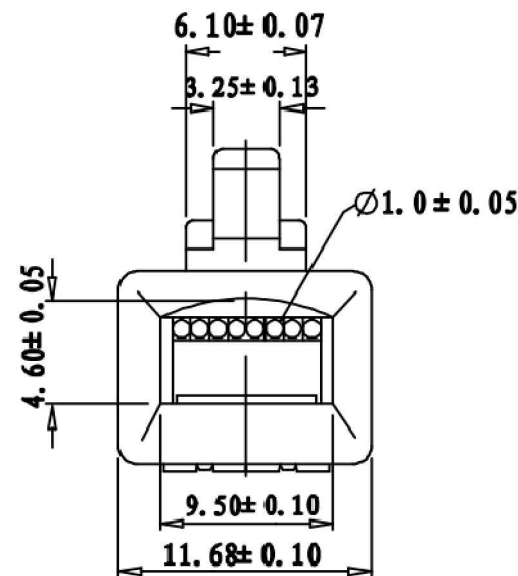
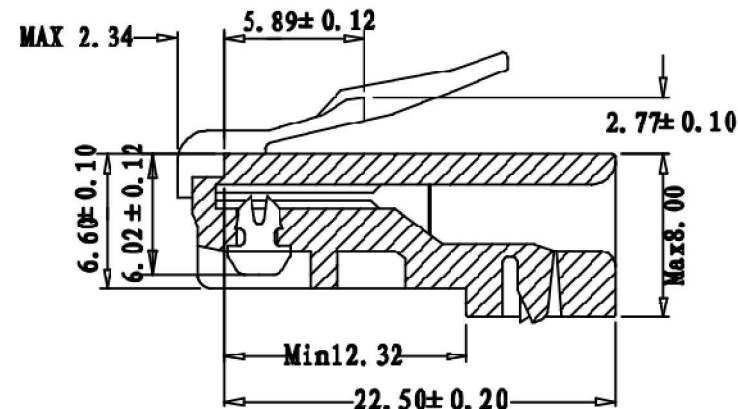
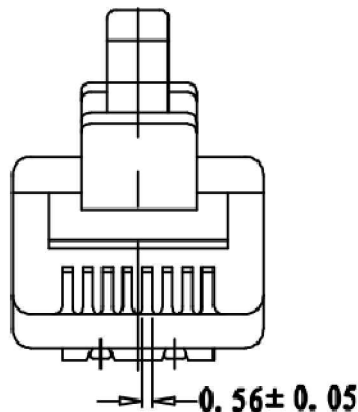

SPECIFICATIONS

HOUSING	POLY CARBONATE (PC) UL94V2
CONTACT BLADE	HIGH STRENGTH COPPER ALLOY
MATERIAL	100 MICRON NICKEL UNDERPLATED
PLATING TYPE	8% PHOSPHOR BRONZE
PLATING THICKNESS:	GOLD PLATED 6U*
OPERATING TEMP	-40° C TO 125° C
CURRENT RATING	250V AC MAX AT 2A
DIELECTRIC	500V AC
INSULATION RES	500MGAOHMS

COMPLIES WITH FCC68/F

RoHS compliant
Unit: mm

Scale	Free						
TOLERANCE							
X.							
X.X							
X.XX							
DIM	TOL						
X.°	±3°						
X.X°	±1.0°	①	Drawn	04.06.2014	Joanna		
Angle	TOL	Id.	Modification	Date	Name		



Customer-No.		
Drawn	04.06.2014	Joanna
Approved	04.06.2014	Joanna
ASSMANN WSW-No.		A-MO-8/8-SR
Drawing-No.		ASS 6402 CO
Replace		rev00
		Sheet