



## DESCRIPTION

The PT2607 Encoder Series are tri-state remote control encoder ICs utilizing CMOS Technology. It encodes data and address pins into a serially encoded waveform suitable for RF modulation. PT2607 supports up to a maximum 12 address and 8 address/data bits. Housed in either 18, 20 or 24 pins, SOP or DIP Package, PT2607's pin assignments and application circuit are optimized for easy PCB Layout and cost saving benefits.

## FEATURES

- CMOS technology
- Low power consumption
- Operating voltage: 2.4 to 15V
- Low standby current
- Three words transmission
- Built-in oscillator
- Least external components
- Available in 18, 20 or 24 pins, DIP or SOP package
- Easy to use

## APPLICATIONS

- Burglar alarm system
- Car/Motorcycle security system
- Home/Office security system
- Smoke & fire alarm system
- Toy/Garage door remote controller
- Cordless telephone
- Object finder
- Remote switch
- Remote control for industrial use
- Automation system



## BLOCK DIAGRAM

**DATA TRIGGER TYPE: PT2607, PT2607-S**

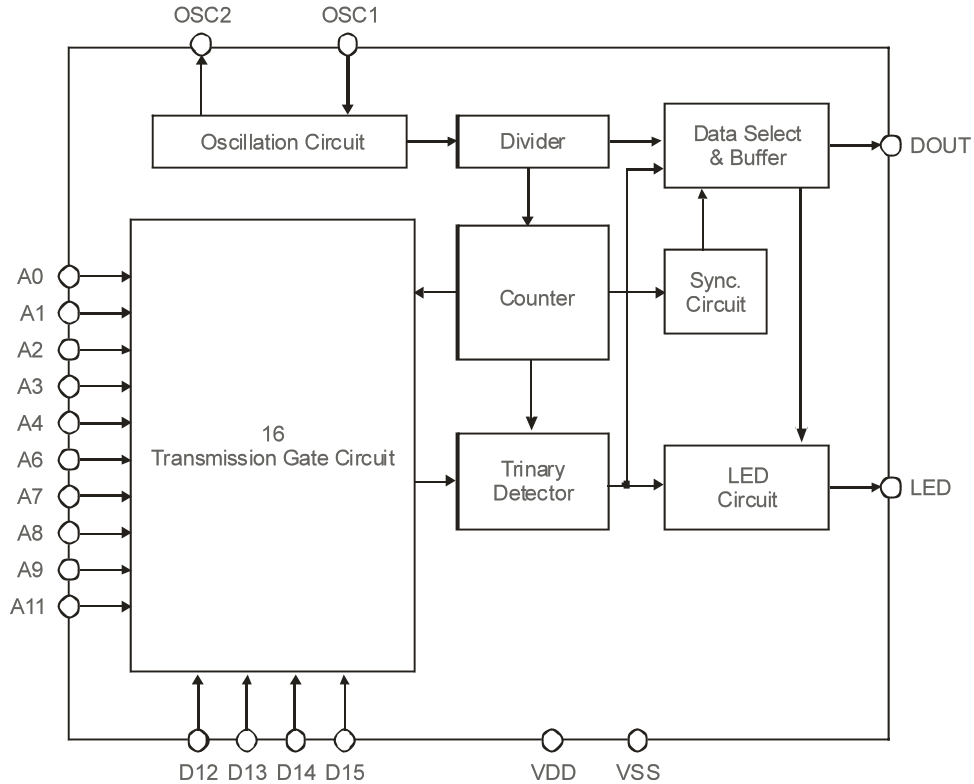



**TE TRIGGER: PT2607B, PT2607B-S, PT2607C, PT2607C-S**

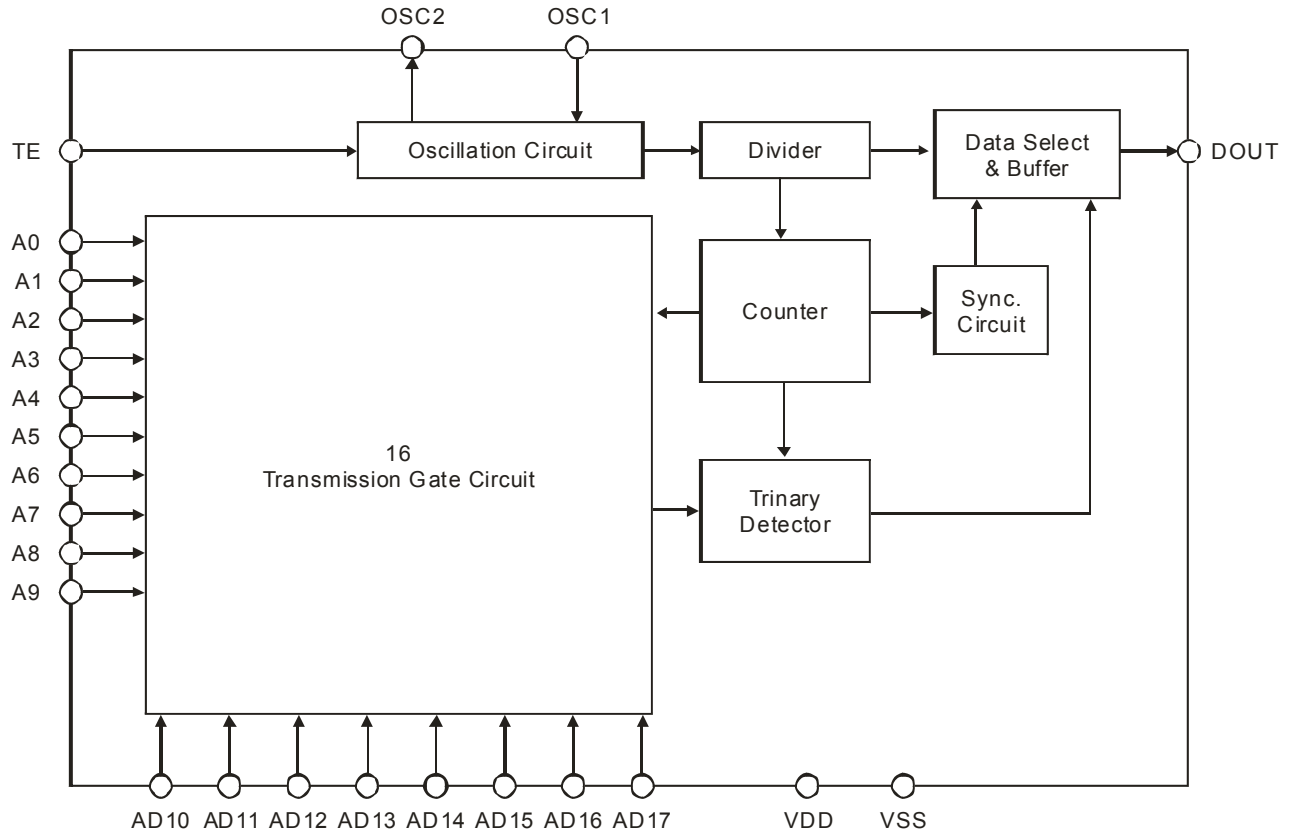



## PIN CONFIGURATION

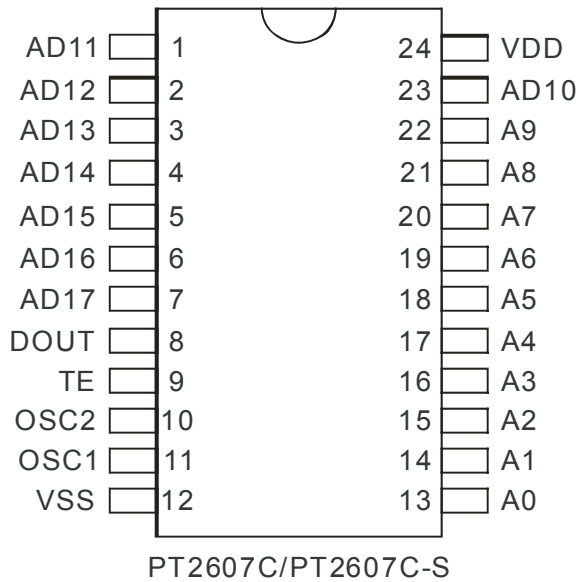
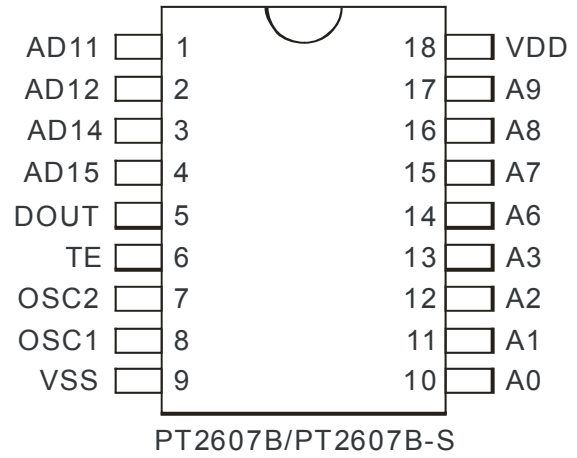
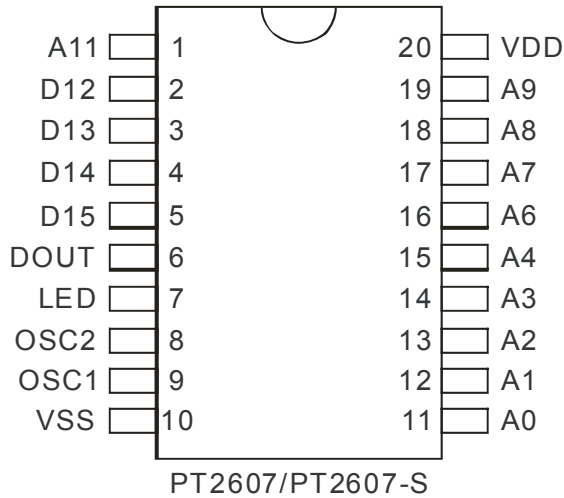



## PIN DESCRIPTION

Pin Name	I/O	Description	Pin No.		
			18 pins	20 pins	24 pins
A11	I	Address pin no. 11 This pin may be externally set to "0", "1" or "floating"	-	1	-
A0~A3	I	Address pin no. 0~3 These pins may be externally set to "0", "1" or "floating"	10~13	11~14	13~16
A4	I	Address pin no. 4 This pin may be externally set to "0", "1" or "floating"	-	15	17
A5	I	Address pin no. 5 This pin may be externally set to "0", "1" or "floating"	-	-	18
A6~A9	I	Address pin no. 6~9 These pins may be externally set to "0", "1" or "floating"	14~17	16~19	19~22
AD10	I	Address/Data Input & Transmission Enable Pins Active high (Internal pull-low resistor) These pins may be externally set to "0", "1" or "floating"	-	-	23
AD11~AD12			1~2	-	1~2
AD13			-	-	3
AD14~AD15			3~4	-	4~5
AD16~AD17			-	-	6~7
D12~D15	I	Data Input and Transmission Enable Pins Active high (Internal pull-low resistor) These pins may be externally set to "0", "1" or "floating"	-	2~5	-
DOUT	O	Data Output Pin	5	6	8
LED	O	LED Indicator Pin	-	7	-
TE	I	Transmission Enable Pin (Active High)	6	-	9
OSC2	O	Oscillator Input Pin	7	8	10
OSC1	I	Oscillator Output Pin	8	9	11
VSS	-	Negative Power Supply	9	10	12
VDD	-	Positive Power Supply	18	20	24



## FUNCTION DESCRIPTION

### OPERATION

Transmission is enabled by setting any one of the data pins -- D12 to D15 to "HIGH" (for PT2607 version) or by setting the TE (for PT2607B and PT2607C versions).

For PT2607 version, when transmission enable signals from Pins -- D12 to D15 -- are received, PT2607 begins a three-word transmission cycle. This three-word transmission cycle will continue as long as the transmission enable (D12 to D15) is held "HIGH". When D12 to D15 goes to "LOW" (that is, the transmission enable become "LOW"), the encoder output completes its final three-word transmission cycle and then stops. Please refer to the diagram below.

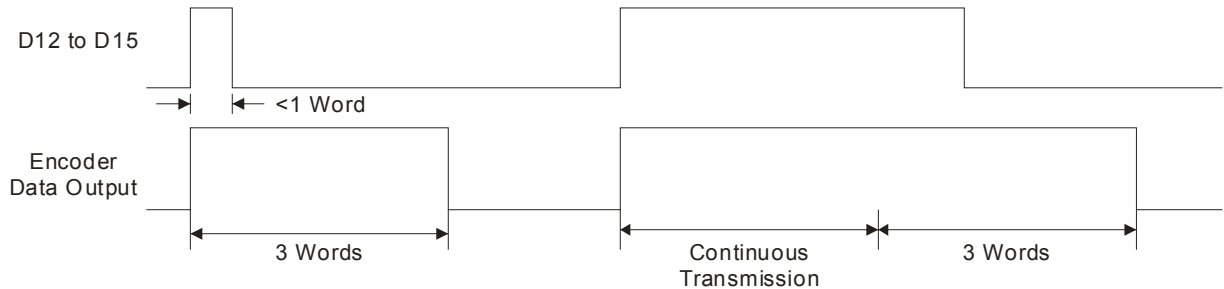

For PT2607B & PT2607C versions, when transmission enable signals from TE is received, PT2607B/PT2607C begins a three-word transmission cycle. This three-word transmission cycle will continue as long as the transmission enable is held "HIGH". When TE goes to "LOW" (that is, the transmission enable become "LOW"), the encoder output completes its final three-word transmission cycle and then stops. Please refer to the diagram below.

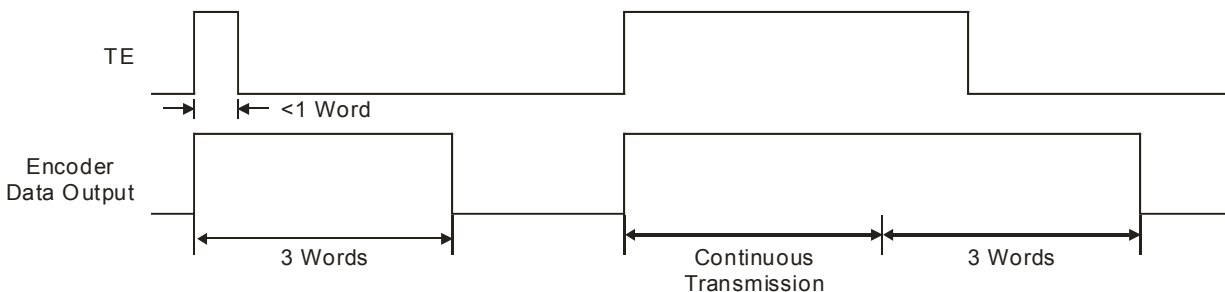





## START BIT

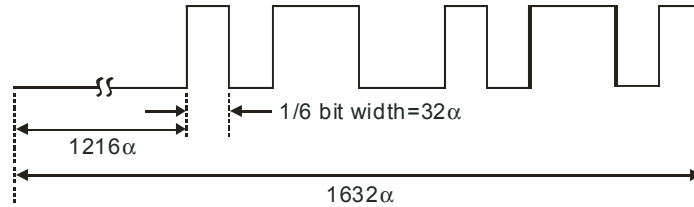

## PRESET ADDRESS/DATA PROGRAMMING

Each address or data pin can be preset to “High”, “Low” or “Floating”. When a transmission enable signal is applied, the encoder scans and transmits serially the status of the 18 bits of address/data in the order of A0 to D17.

## ADDRESS AND DATA SEQUENCE

PT2607 Address and Data Sequence is provided in the table below.

Address Bits:

0~3	4	5	6~9	10	11	12	13	14	15	16	17
A0~A3	A4	*	A6~A9	*	A11	D12	D13	D14	D15	**	**

Notes:

1. \*=Bit 5 and Bit 10 are “open” and internally bonded.
2. \*\*=Bit 16 and Bit 17 are set to “LOW” and are internally bonded.

PT2607B Address and Data Sequence is provided in the table below.

Address Bits:

0~3	4	5	6~9	10	11~12	13	14~15	16	17
A0~A3	*	*	A6~A9	*	AD11~AD12	*	AD14~AD15	*	*

Note: \*=Bits 4,5,10,13,16,17 are “open” and internally bonded.

PT2607C Address and Data Sequence is provided in the table below.

Address Bits:

0	1	2	3	4	5	6	7	8	9	10	11	12	13	14	15	16	17
A0	A1	A2	A3	A4	A5	A6	A7	A8	A9	AD10	AD11	AD12	AD13	AD14	AD15	AD16	AD17





## OPERATION FLOWCHART

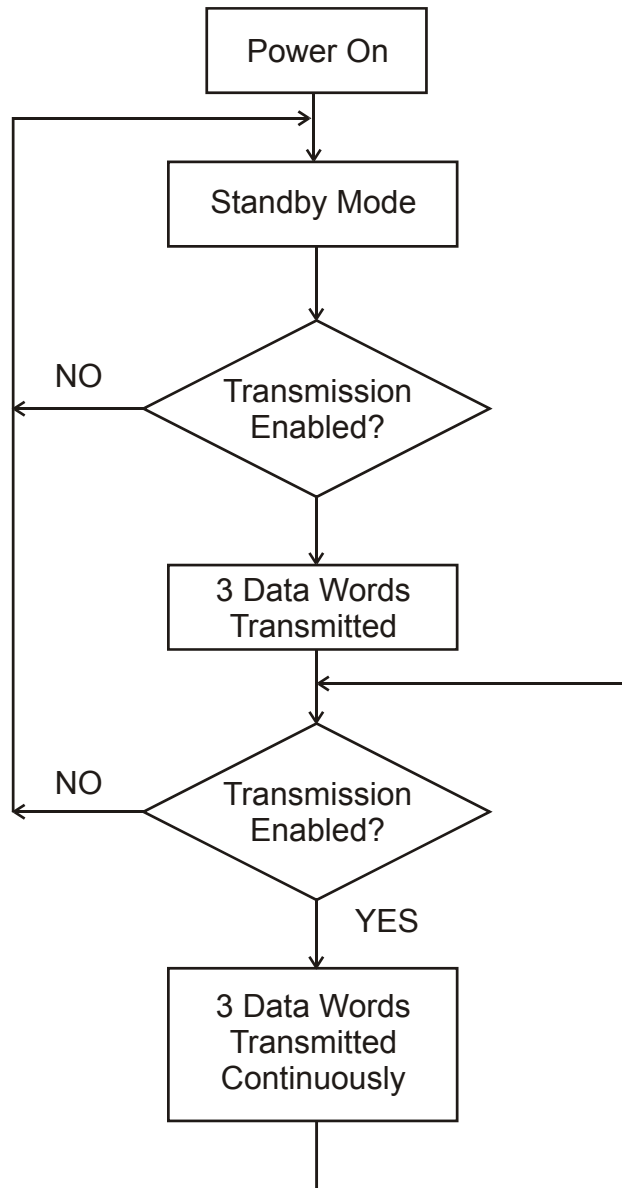

### Notes:

1. D12 to D15 is transmission enable pins of PT2607 version.
2. TE is the transmission enable pin of PT2607B and PT2607C versions.



### OSCILLATION FREQUENCY VS. SUPPLY VOLTAGE

The recommended oscillation frequency of PT2607 ICs must be equal to the oscillation frequency of the decoder. That is,  $F_{osc}(\text{decoder}) = F_{osc}(\text{encoder})$ .

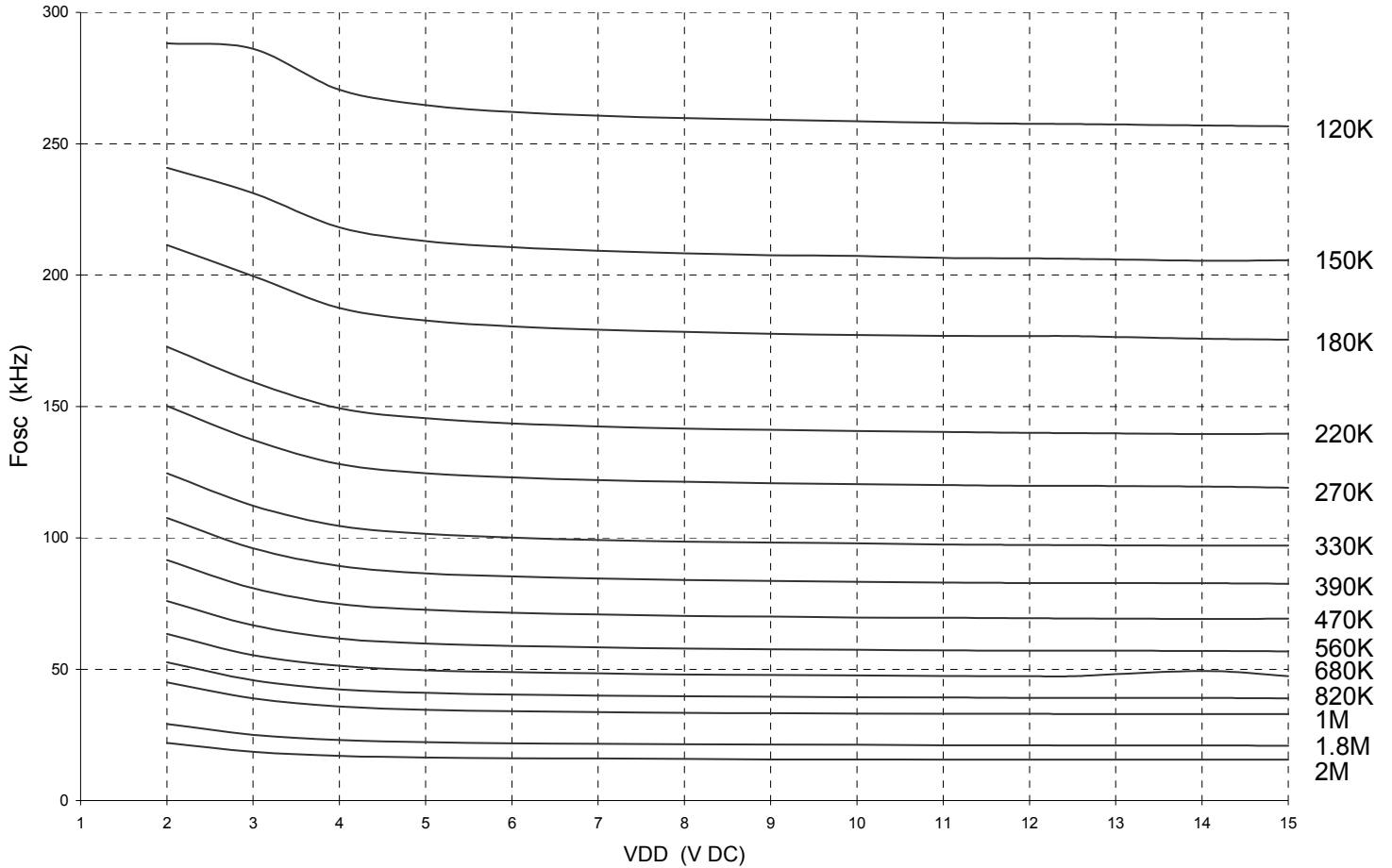



## ABSOLUTE MAXIMUM RATINGS

Parameter	Symbol	Rating	Unit
Operating temperature	Topr	-40 ~ +85	°C
Storage temperature	Tstg	-65 ~ +150	°C

## ELECTRICAL CHARACTERISTICS

(Unless otherwise specified, Ta=25°C)

Parameter	Symbol	Conditions	Min.	Typ.	Max.	Unit
Operating voltage	VDD		2.4	-	15	V
Standby current	ISB	VDD=3V, OSC stops	-	0.1	1	μA
		VDD=12V, OSC stops	-	2	4	
Operating current	IDD	VDD=5V, no load	-	250	500	μA
		VDD=12V, Fosc=100KHz	-	1200	2400	
LED sink current	ILED	VDD=5V, VLED=0.5V	1.5	3	-	mA
Output current	IDOUT	VDD=5V, VOH=0.9VDD (Drive)	-0.6	-1.2	-	mA
		VDD=5V, VOL=0.1VDD (Sink)	0.6	1.2	-	
High level input voltage	VIH		0.8VDD	-	VDD	V
Low level input voltage	VIL		0	-	0.2VDD	V
Oscillator frequency	Fosc	VDD=10V, Rosc=330KΩ	-	100	-	KHz
D12 to D15 pull low resistance	RDATA	VDD=5V, VDATA=5V	-	1.5	3	MΩ



# APPLICATION CIRCUIT

## PT2607-1

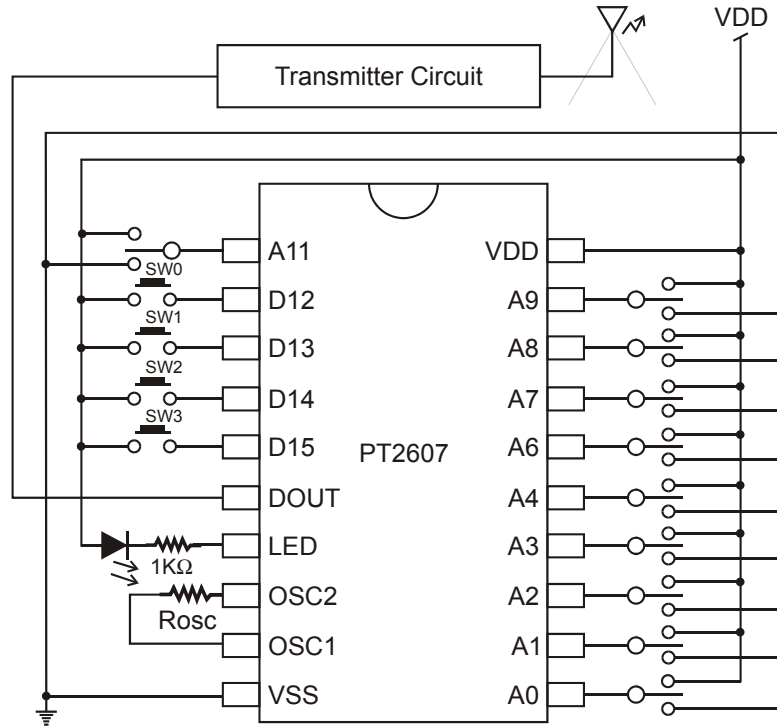

## PT2607-2

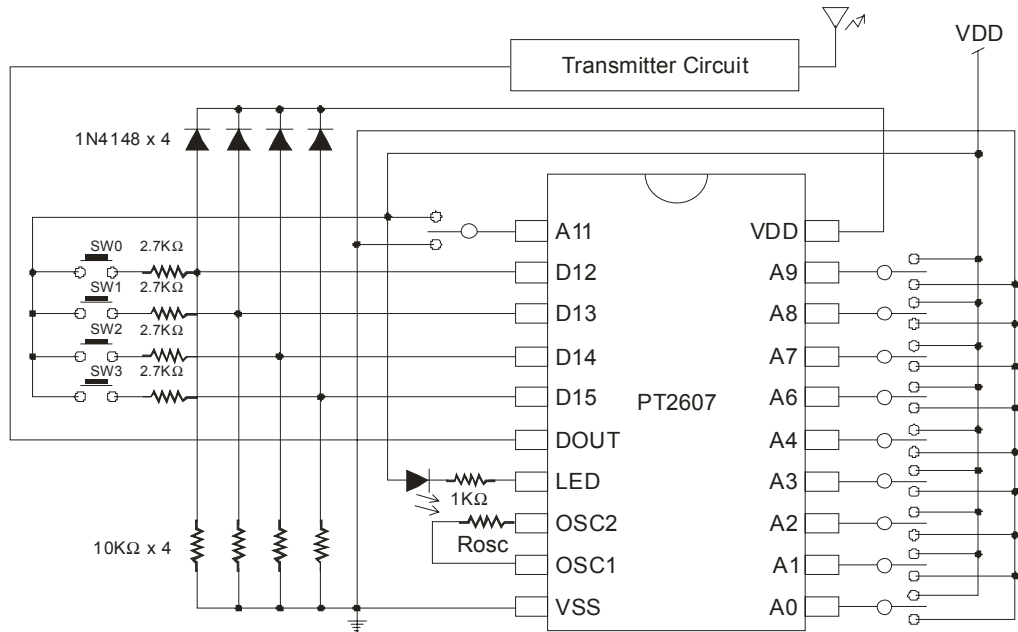



**PT2607B -1**

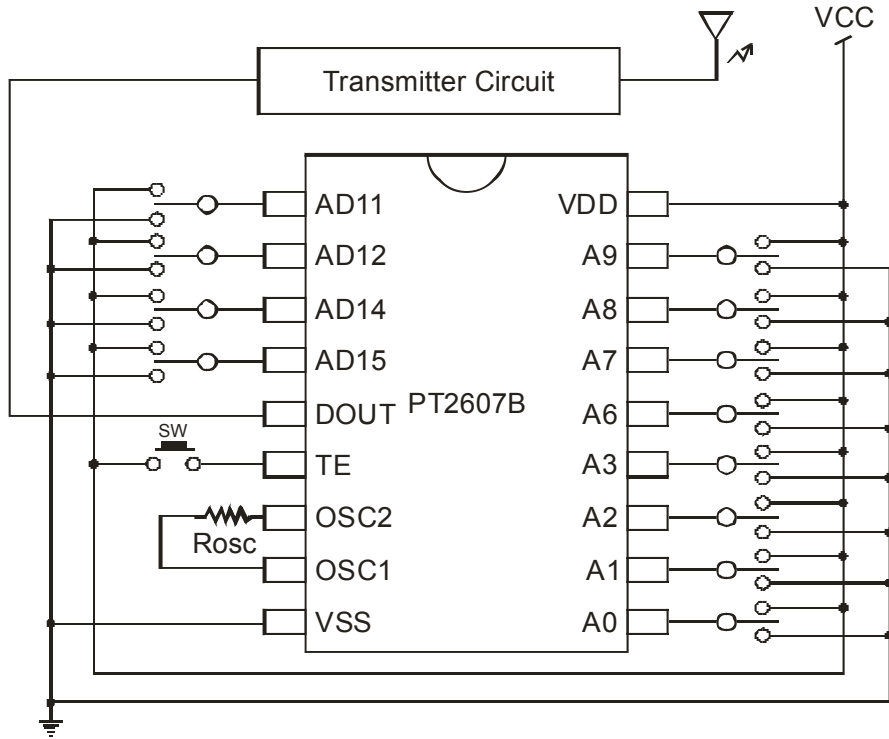

**PT2607B-2**

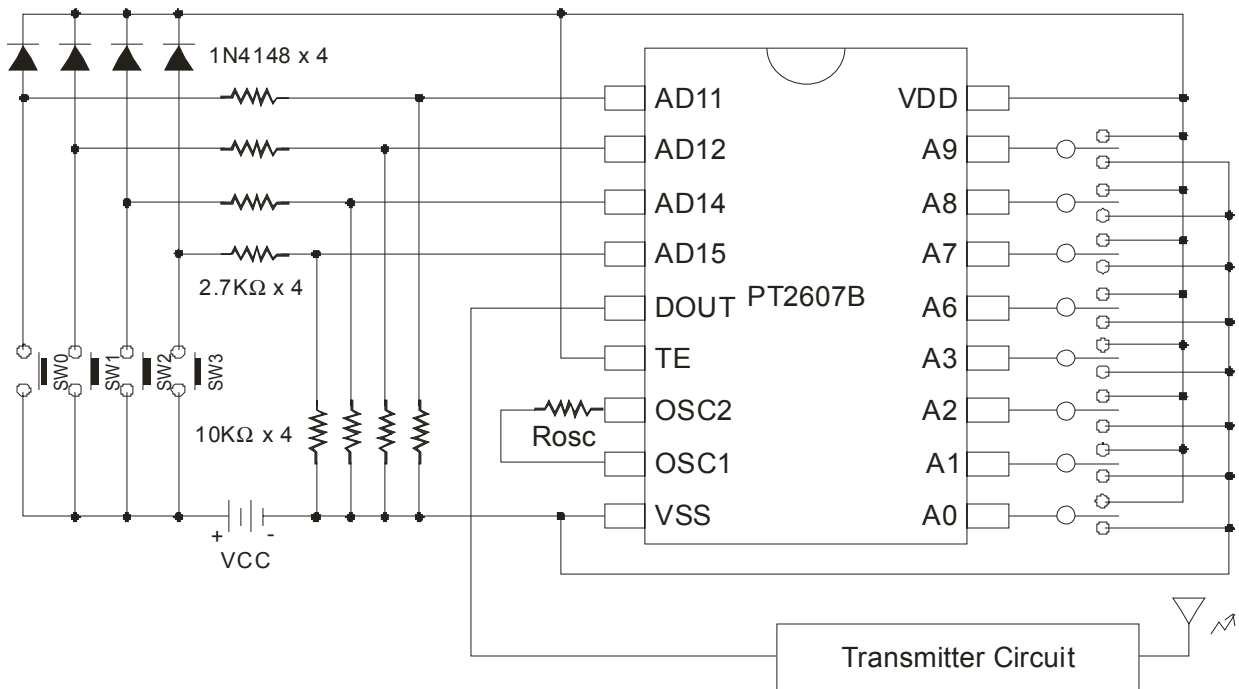



PT2607C-1

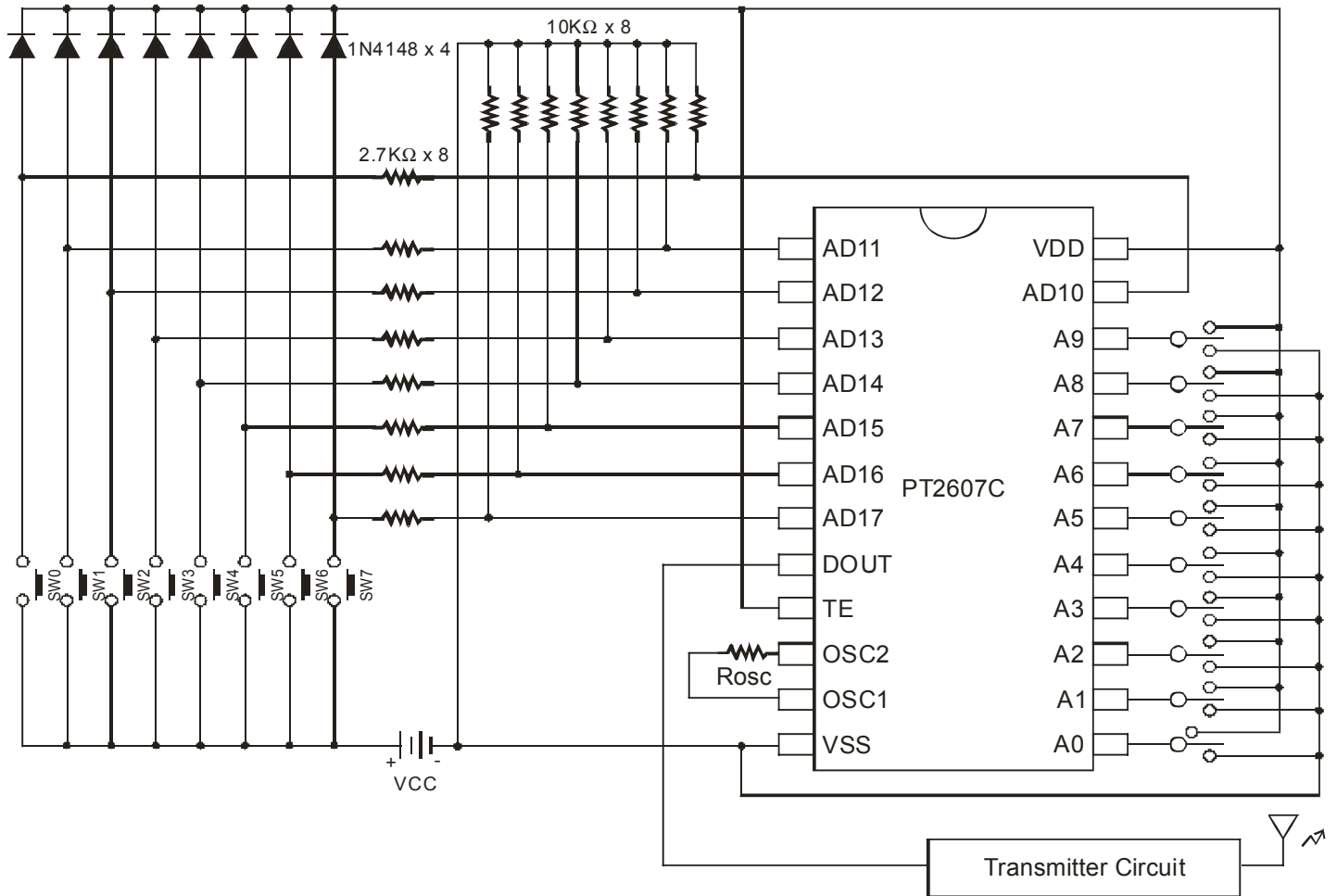



PT2607C-2

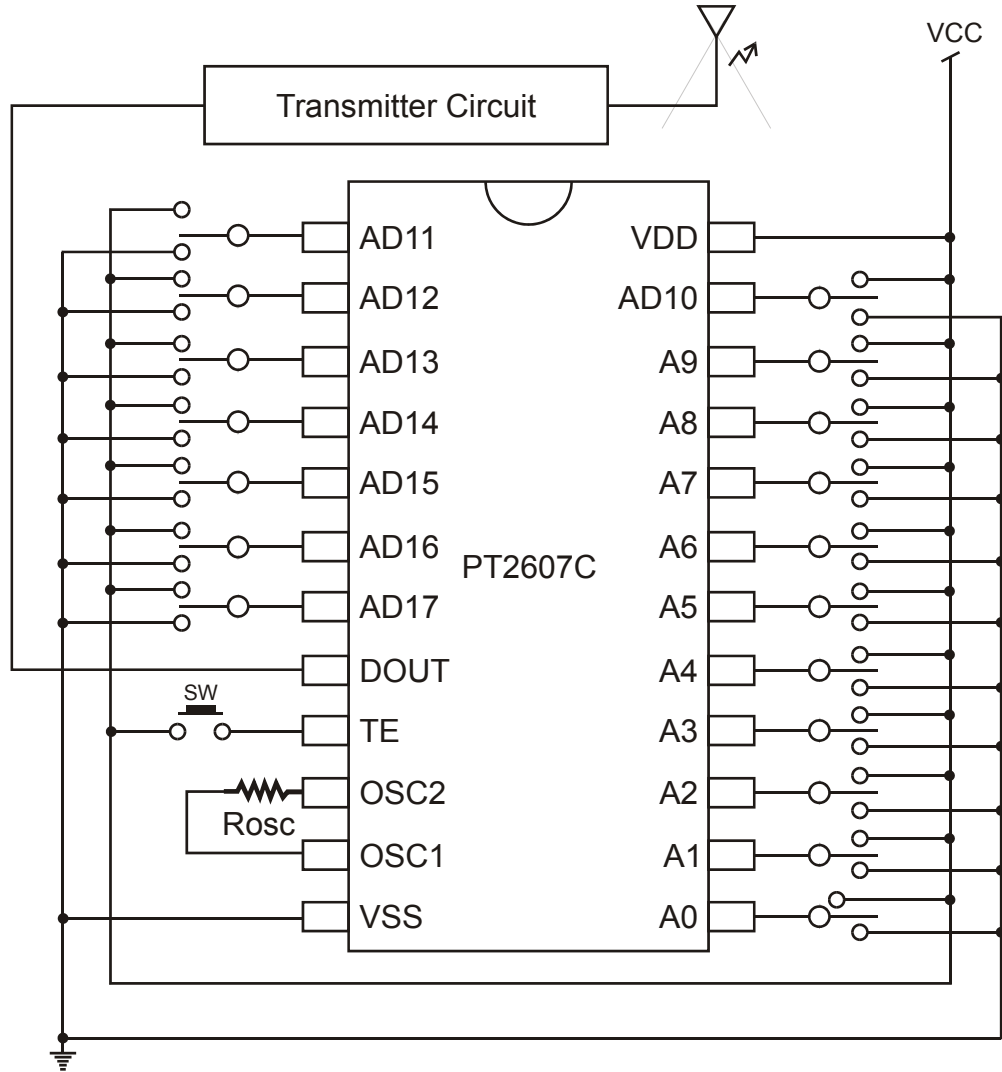



## ORDER INFORMATION

Valid Part Number	Package Type	Top Code
PT2607	20 Pins, DIP, 300mil	PT2607
PT2607-S	20 Pins, SOP, 300mil	PT2607-S
PT2607-B	18 Pins, DIP, 300mil	PT2607B
PT2607B-S	18 Pins, SOP, 300mil	PT2607B-S
PT2607-C	24 Pins, DIP, 300mil	PT2607C
PT2607C-S	24 Pins, SOP, 300mil	PT2607C-S





# PACKAGE INFORMATION

20 PINS, DIP, 300MIL

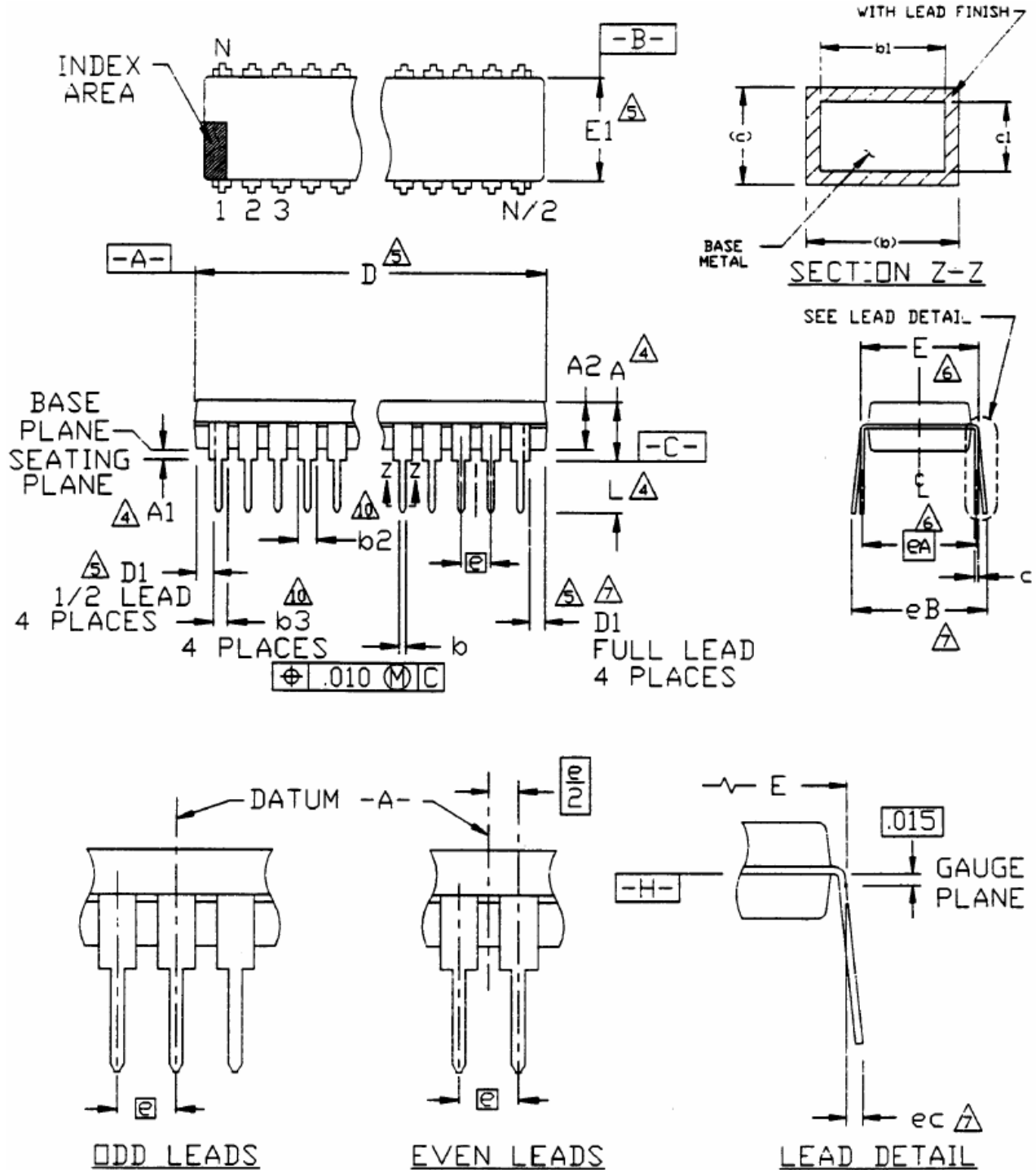



Symbol	Min.	Nom.	Max.
A	-	-	0.210
A1	0.015	-	-
A2	0.115	0.130	0.195
b	0.014	0.018	0.022
b1	0.014	0.018	0.020
b2	0.045	0.060	0.070
b3	0.030	0.039	0.045
c	0.008	0.010	0.014
c1	0.008	0.010	0.011
D	0.980	1.030	1.060
D1	0.005	-	-
E	0.300	0.310	0.325
E1	0.240	0.250	0.280
e	-	0.100 bsc.	-
eA	-	0.300 bsc.	-
eB	-	-	0.430
eC	0.000	-	0.060
L	0.115	0.130	0.150

Notes:

- All dimensions are in INCHES.
  - Dimensioning and tolerancing per ANSI Y14.5M-1982.
  - Dimension "A", "A1" and "L" are measured with the package seated in JEDEC Seating Plane Gauge GS-3
  - "D", "D1" and "E1" dimensions do not include mold flash or protrusions. Mold flash or protrusions shall not exceed 0.010 inch.
  - "E" and "eA" measured with the leads constrained to be perpendicular to datum  $\square C$ .
  - "eB" and "eC" are measured at the lead tips with the leads unconstrained.
  - N is the number of the terminal positions (N=20)
  - Pointed or rounded lead tips are preferred to ease insertion.
  - "b2" and "b3" maximum dimensions are not include dambar protrusions. Dambar protrusions shall not exceed 0.010 inch (0.25mm)
  - Distance between leads including dambar protrusions to be 0.005 inch minimum.
  - Datum plane  $\square H$  coincident with the bottom of lead, where lead exits body.
  - Refer to JEDEC MS-001, Variation AD.
- JEDEC is the trademark of JEDEC SOLID STATE TECHNOLOGY ASSOCIATION.



Remote Control Encoder IC

PT2607

20 PINS, SOP, 300MIL

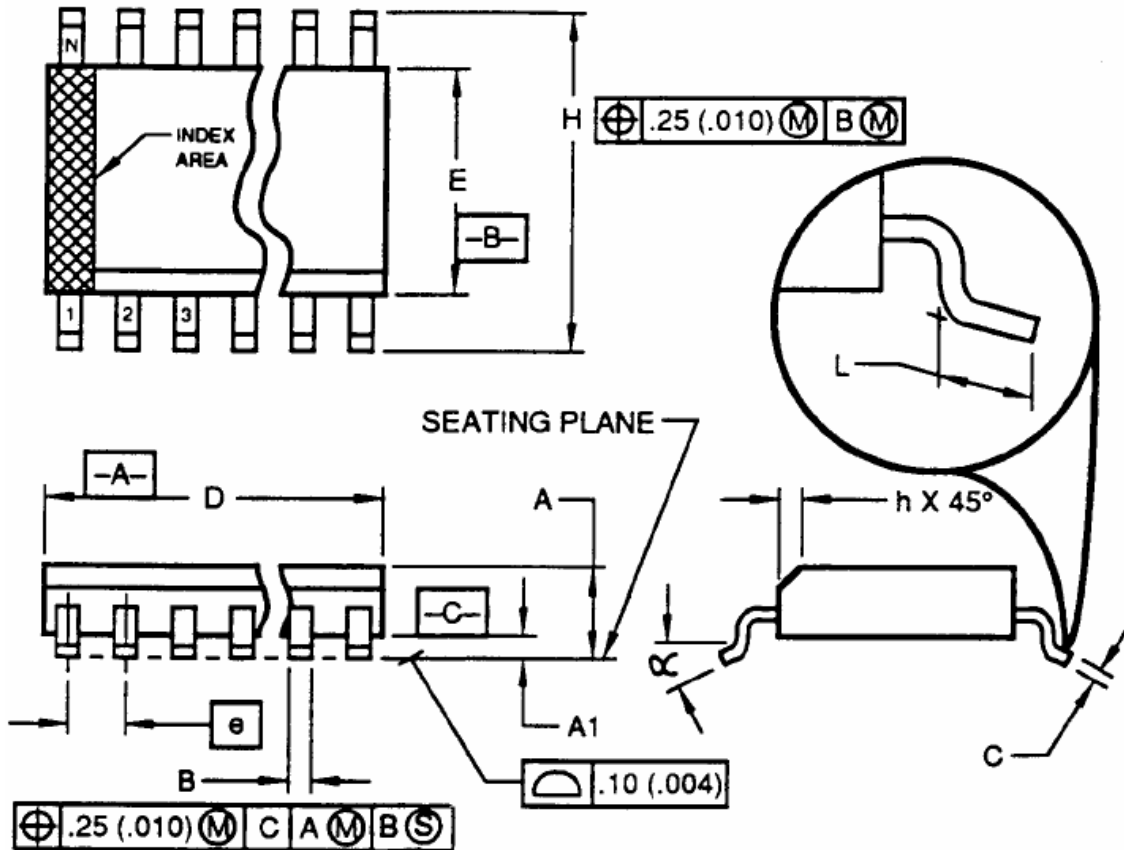

Symbol	Min.	Nom.	Max.
A	2.35	-	2.65
A1	0.10	-	0.30
B	0.33	-	0.51
C	0.23	-	0.32
D	12.60	-	13.00
E	7.40	-	7.60
e	-	1.27 bsc.	-
H	10.00	-	10.65
h	0.25	-	0.75
L	0.40	-	1.27
$\alpha$	0°	-	8°



## Remote Control Encoder IC

**PT2607**

### Notes:

1. Dimensioning and tolerancing per ANSI Y14.5M-1982.
2. Dimension "D" does not include mold flash, protrusions or gate burrs. Mold Flash, protrusion or gate burrs shall not exceed 0.15 mm (0.006 in) per side.
3. Dimension "E" does not include interlead flash or protrusions. Interlead flash or protrusions shall not exceed 0.25 mm (0.010 in) per side.
4. The chamfer on the body is optional. If it is not present, a visual index feature must be located within the crosshatched area.
5. "L" is the length of the terminal for soldering to a substrate.
6. N is the number of the terminal positions (N=20)
7. The lead width "B" as measured 0.36 mm (0.014 in) or greater above the seating plane, shall not exceed a maximum value of 0.61 mm (0.24 in).
8. Controlling dimension: MILLIMETER.
9. Refer to JEDEC MS-013, Variation AC.

JEDEC is the trademark of JEDEC SOLID STATE TECHNOLOGY ASSOCIATION.



Remote Control Encoder IC

PT2607

18 PINS, DIP, 300MIL

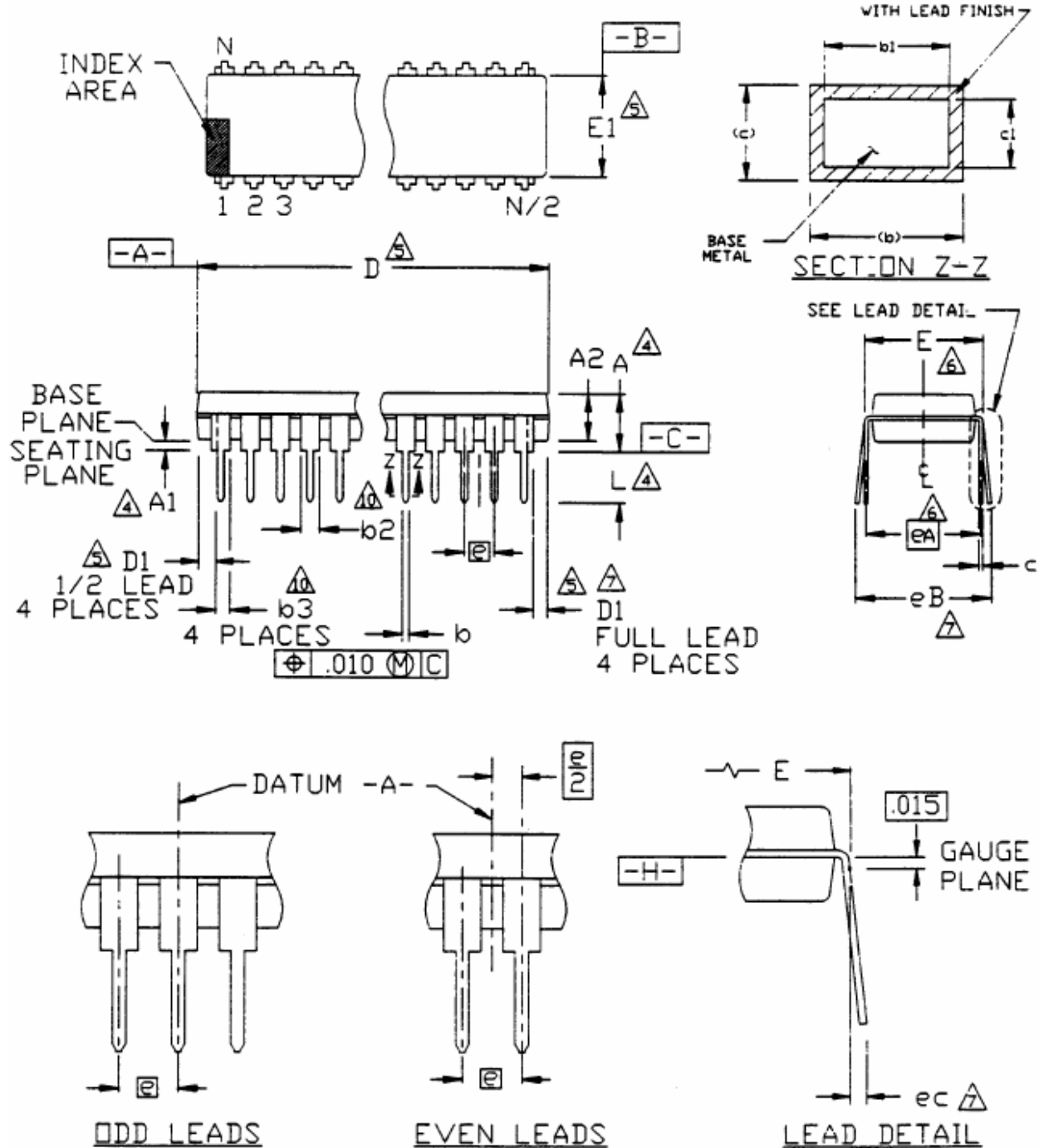



Symbol	Min.	Nom.	Max.
A			0.210
A1	0.015		
A2	0.115	0.130	0.195
b	0.014	0.018	0.022
b1	0.014	0.018	0.020
b2	0.045	0.060	0.070
b3	0.030	0.039	0.045
c	0.008	0.010	0.014
c1	0.008	0.010	0.011
D	0.880	0.900	0.920
D1	0.005		
E	0.300	0.310	0.325
E1	0.240	0.250	0.280
e	0.100 bsc.		
eA	0.300 bsc.		
eB			0.430
eC	0.000		0.060
L	0.115	0.130	0.150

Notes:

- All dimensions are in INCHS.
- Dimensioning and tolerancing per ANSI Y14.5M-1982.
- Dimensions "A", "A1" and "L" are measured with the package seated in JEDEC Seating Plane Gauge GS-3.
- "D", "D1" and "E1" dimensions do not include mold flash or protrusions. Mold flash or protrusions shall not exceed 0.010 inch.
- "E" and "eA" measured with the leads constrained to be perpendicular to datum  $\square{-C-}$ .
- "eB" and "eC" are measured at the lead tips with the loads unconstrained.
- "N" is the number of terminal positions. (N=18)
- Pointed or rounded lead tips are preferred to ease insertion.
- "b2" and "b3" maximum dimensions are not include dambar protrusions. Dambar protrusions shall not exceed 0.010 inch (0.25 mm).
- Distance between leads including Dambar protrusions to be 0.005 inch minimum.
- Datum plane  $\square{-H-}$  coincident with the bottom of lead, where lead exits body.
- Refer to JEDEC MS-001 Variation AC.

JEDEC is the trademark of JEDEC SOLID STATE TECHNOLOGY ASSOCIATION.





## Remote Control Encoder IC

**PT2607**

### Notes:

1. Dimensioning and tolerancing per ANSI Y14.5M-1982.
  2. Dimension "D" does not include mold flash, protrusions or gate burrs. Mold Flash, protrusion or gate burrs shall not exceed 0.15 mm (0.006 in) per side.
  3. Dimension "E" does not include interlead flash or protrusions. Interlead flash or protrusions shall not exceed 0.25 mm (0.010 in) per side.
  4. The chamfer on the body is optional. If it is not present, a visual index feature must be located within the crosshatched area.
  5. "L" is the length of the terminal for soldering to a substrate.
  6. N is the number of the terminal positions (N=18)
  7. The lead width "B" as measured 0.36 mm (0.014 in) or greater above the seating plane, shall not exceed a maximum value of 0.61 mm (0.24 in).
  8. Controlling dimension: MILLIMETER.
  9. Refer to JEDEC MS-013, Variation AB.
- JEDEC is the trademark of JEDEC SOLID STATE TECHNOLOGY ASSOCIATION.





Remote Control Encoder IC

PT2607

24 PINS, DIP, 300MIL

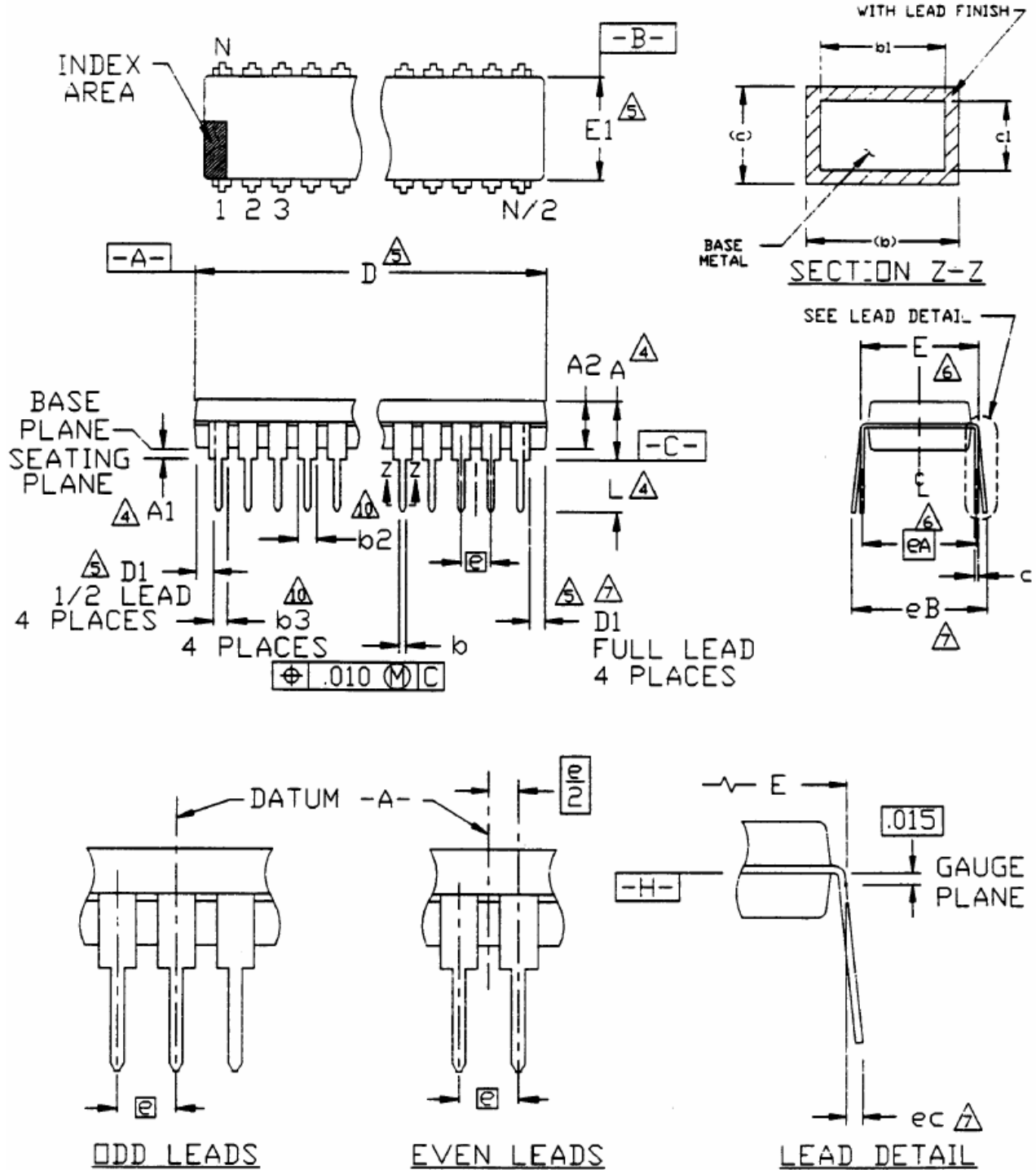



Symbols	Dimensions		
	Min.	Nom.	Max.
A			0.210
A1	0.015		
A2	0.115	0.130	0.195
b	0.014	0.018	0.022
b1	0.014	0.018	0.020
b2	0.045	0.060	0.070
b3	0.030	0.039	0.045
c	0.008	0.010	0.014
c1	0.008	0.010	0.011
D	1.160	1.185	1.195
D1	0.005		
E	0.300	0.310	0.325
E1	0.240	0.250	0.280
e	0.100 bsc.		
eA	0.300 bsc.		
eB			0.430
eC	0.000		0.060
L	0.115	0.130	0.150

Notes:

- All dimensions are in INCHES.
  - Dimensioning and tolerancing per ANSI Y 14.5-1982.
  - Dimension "A", "A1" and "L" are measured with the package seated in JEDEC Seating Plane Gauge GS-3.
  - "D", "D1" and "E1" dimensions do not include mold flash or protrusions. Mold flash or protrusions shall not exceed 0.010 inch.
  - "E" and "eA" measured with the leads constrained to be perpendicular to datum  $\square\text{-C-}$ .
  - "eB" and "eC" are measured at the lead tips with the leads unconstrained.
  - N is the number of terminal positions. (N=24)
  - Pointed or rounded lead tips are preferred to ease insertion.
  - "b2" and "b3" maximum dimensions are not include dambar protrusions. Dambar protrusions shall not exceed 0.010 inch (0.25mm)
  - Distance between leads including Dambar protrusions to be 0.005 inch. minimum.
  - Datum plane  $\square\text{-H-}$  coincident with the bottom of lead, where lead exits body.
  - Refer to JEDEC MS-001, Variation BE.
- JEDEC is the trademark of JEDEC SOLID STATE TECHNOLOGY ASSOCIATION.



24 PINS, SOP, 300MIL

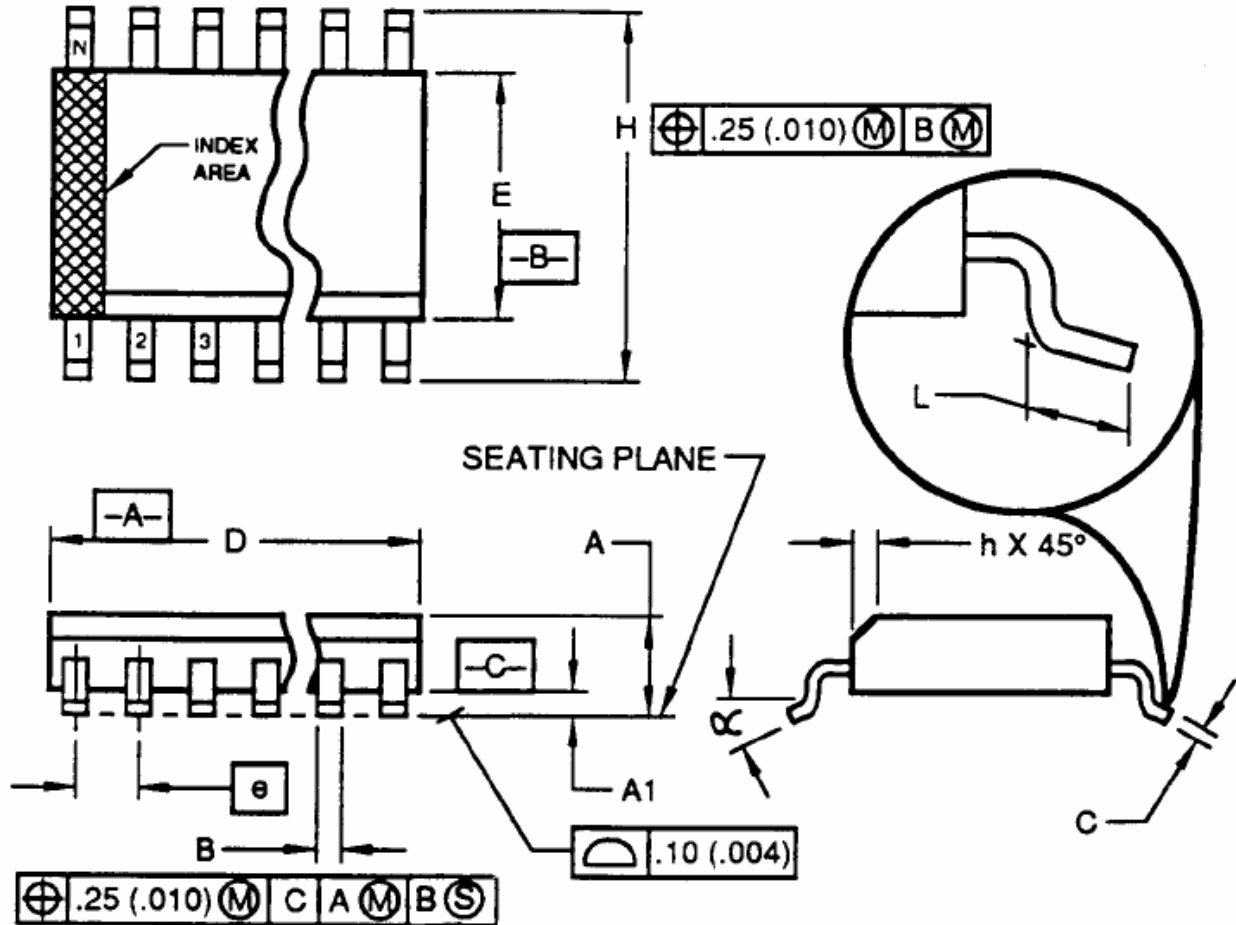

Symbols	Min.	Nom.	Max.
A	2.35		2.65
A1	0.10		0.30
B	0.33		0.51
C	0.23		0.32
D	15.20		15.60
E	7.40		7.60
e	1.27 bsc.		
H	10.00		10.65
h	0.25		0.75
L	0.40		1.27
$\alpha$	0°		8°



## Remote Control Encoder IC

**PT2607**

### Notes:

1. Dimensioning and tolerancing per ANSI Y 14.5-1982.
2. Dimension "D" does not include mold flash, protrusions or gate burrs. Mold Flash, protrusion or gate burrs shall not exceed 0.15mm (0.006 in) per side.
3. Dimension "E" does not include interlead flash protrusions. Interlead flash or protrusions shall not exceed 0.25 mm (0.010 in) per side.
4. The chamfer on the body is optional. If it is not present, a visual index feature must be located within the crosshatched area.
5. "L" is the length of the terminal for soldering to a substrate.
6. "N" is the number of terminal position. (N=24)
7. The lead width "B" as measured 0.36 mm (0.014 in) or greater above the seating plane, shall not exceed a maximum value of 0.61mm (0.24 in).
8. Controlling dimension: MILLIMETER.
9. Refer to JEDEC MS-013, Variation AD.

JEDEC is the trademark of JEDEC SOLID STATE TECHNOLOGY ASSOCIATION.