

Current Transducer LA 03 .. 20-PB

$$I_{PN} = 3 \dots 20 \text{ A}$$

For the electronic measurement of currents: DC, AC, pulsed, mixed, with a galvanic isolation between the primary circuit (high power) and the secondary circuit (electronic circuit).

Preliminary



Electrical data

Primary nominal r.m.s. current I_{PN} (A)	Primary current measuring range I_p (A)	Primary Conductor Diameter (mm)	Type
3	± 4.5	0.5	LA 03-PB
5	± 7.5	0.5	LA 05-PB
10	± 15	0.65	LA 10-PB
15	± 22.5	0.8	LA 15-PB
20	± 30	1.0	LA 20-PB

V_C	Supply voltage ($\pm 5\%$)	± 15	V
I_C	Current consumption	app. 20mA + $I_{PN}/1200$ mA	
V_d	R.m.s. voltage for AC isolation test, 50/60Hz, 1mn	2.5	kV
R_{IS}	Isolation resistance @ 500 VDC	> 500	M Ω
V_{OUT}	Output voltage @ $\pm I_{PN}$, $R_L = 10 \text{ k}\Omega$, $T_A = 25^\circ\text{C}$	± 4	V
R_L	Load resistance	> 10	k Ω

Accuracy-Dynamic performance data

X	Accuracy @ I_{PN} , $T_A = 25^\circ\text{C}$ (without offset)	$< \pm 1.5\%$ of I_{PN}
e_L	Linearity ($0 \dots \pm I_{PN}$)	$< \pm 1\%$ of I_{PN}
V_{OE}	Electrical offset voltage, $T_A = 25^\circ\text{C}$	$< \pm 30$ mV
V_{OH}	Hysteresis offset voltage @ $I_p = 0$; after an excursion of $1 \times I_{PN}$	$< \pm 15$ mV
V_{OT}	Thermal drift of V_{OE}	max. ± 1 mV/K
TCE_G	Thermal drift(% of reading)	$< 0.04\%$ /K
t_r	Response time @ 90% of I_p	< 3 μs
f	Frequency bandwidth (-1dB) ¹⁾	DC .. 150 kHz

General data

T_A	Ambient operating temperature	- 10 .. + 80 °C
T_S	Ambient storage temperature	- 15 .. + 85 °C
m	Mass	< 12 g

Notes : EN 50178 approval pending

¹⁾ Derating is needed to avoid excessive core heating at high frequency.

Features

- Closed loop (compensation) current transducer using the Hall effect
- Voltage output
- Printed circuit board mounting

Advantages

- Excellent accuracy
- Very good linearity
- Low temperature drift
- Optimized response time
- Wide frequency bandwidth
- No insertion losses
- High immunity to external interference
- Current overload capacity

Applications

- AC variable speed drives and servo motor drives
- Static converters for DC motor drives
- Battery supplied applications
- Uninterruptible Power Supplies (UPS)
- Switched Mode Power Supplies (SMPS)
- Switched Mode Power Supplies (SMPS)
- Power supplies for welding applications

LA 03 ... 20-PB

Front View

Right View

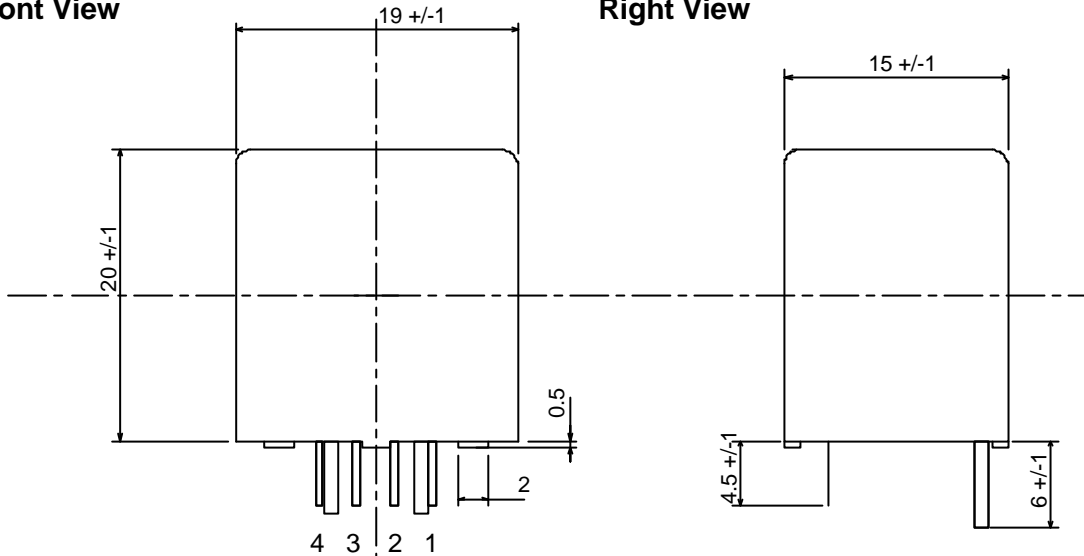

Primary Conductor
See the attached table

Bottom View

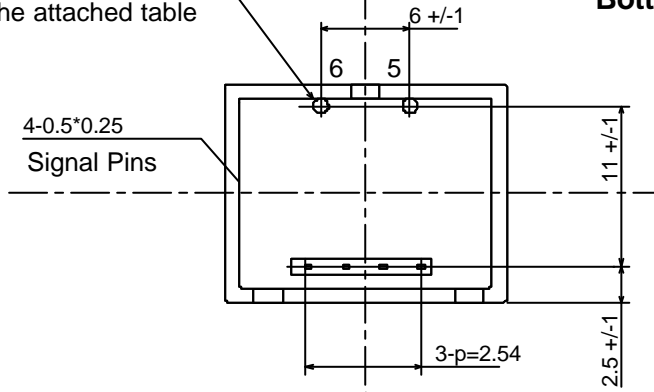

Terminal Pin Identification

Primary Conductor

Part No.	Diameter
LA 03-PB	0.5 d
LA 05-PB	0.5 d
LA 10-PB	0.65 d
LA 15-PB	0.8 d
LA 20-PB	1.0 d

Signal Pins

1	-Vcc
2	0V
3	+Vcc
4	Output

Direction of Current Flow

5 (+) → 6 (-)

UNIT : mm