

CUSTOMER

Residual current sensor FG-R05-3A datasheet

**KEMET
Corporation**

TOKIN Corporation
MSABG – Magnetics, Sensor and
Actuator Unit

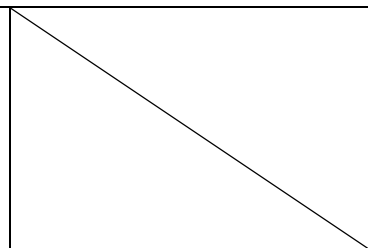

1. Scope

This datasheet applies to the specification of Residual current sensor FG-R05-3A

2. Introduction

This sensor FG-R05-3A is a high-sensitivity DC/AC current sensor that can detect leakage current of DC and AC. If DC fault occurs, PIN 4 will change state from low level to high impedance. If AC fault occurs, PIN5 will change state from low level to high impedance.

This sensor has a test coil for testing the operation of the sensor, and by inputting a signal from the outside it is possible to pass a test current to the test coil. It also outputs a digital signal informing that leakage current of DC/AC has been detected.

Features

- For IC-CPD to the standard IEC 62752:2016
- UL2231(CCID20)
- Open-loop, Flux-gate type current sensor
- PCB mounting
- Digital output of fault detection

3. Pin assignment

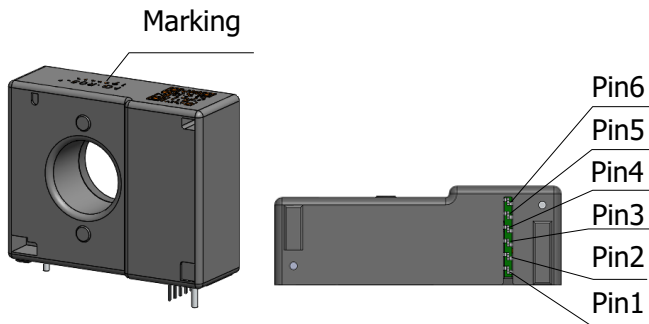

Parameter	Specification Typ.	Units
Dimension	38 x 31 x 13	mm
Inner diameter	φ12.6	mm
Mass	18	g

Pin No.	Symbol	Pin type	Functions
1	VDD	Power	Power supply, 5V
2	GND	Power	Ground
3	AOUT	Analog out.	Analog output. This is for monitoring purposes and is not safety function! Offset voltage is 2.25 V(Typ.). Sensitivity is 40V/A(Typ.)
4	DC Alarm	Digital Out	Active high if DC current is in the range of 3 to 6mA. Pull up to VDD with 1k-ohm resistor.
5	AC Alarm	Digital Out	Active high if AC current is in the range of 15 to 20mA. Pull up to VDD with 1k-ohm resistor IEC62752 & UL2231(CCID20)
6	TEST	Input	Test input. Internal pull-down with 100kohm. When input positive pulse input(>120usec), test sequence is start.

4. Marking

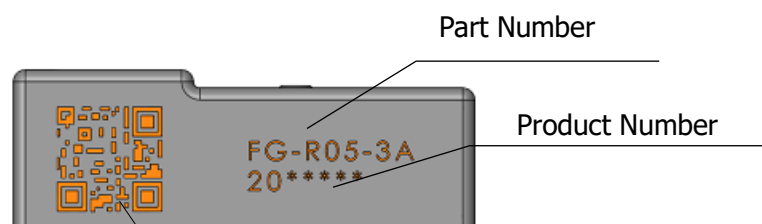

2D Code : Purpose for Internal manufacturing control * out of spec.

5. Absolute maximum ratings

5-1. Environmental characteristics

Parameter	Min	Max	Units
Operating temperature range	-40	+85	°C
Storage temperature range	-40	+85	°C

5-2. Electrical characteristics

Parameter	Min	Max	Units
Supply voltage	-0.3	6.0	V
Primary rated voltage		250	V
Maximum input voltage of digital output		Vdd+0.3	V
Maximum sink current of digital output		10	mA
Input voltage of TEST (LOW)	0	0.6	V
Input voltage of TEST (HIGH)	2.5	Vdd	V

6. Specifications

6-1. Electrical characteristics

Unless otherwise specified, each electrical operating condition is TA = 25°C, Vdd = 5 V.

Parameter	Symbol	Min.	Typ.	Max.	Units	Comments
Primary nominal current	In			80/40	A	1phase/3phase
Supply voltage	Vdd	4.75	5.0	5.25	V	
Current consumption	Ic		13		mA	Ip = 0mA
DC6mA detection current	I _{dn} (DC)	3	4.5	6	mA	-40 to 85°C
AC30mA detection current	I _{dn} (AC)	15	17.5	20	mA	-40 to 85°C, 55Hz
Frequency characteristic of I _{dn} (AC)		-2	-1		%	@45Hz/55Hz
			+1	+2	%	@65Hz/55Hz
Recovery level			I _{dn} /2			
DC Fault response time			140	1000	ms	I _p = DC6mA
			12	250	ms	I _p = DC60mA
			3	15	ms	I _p = DC300mA
AC Fault response time			100	250	ms	I _p = AC30mArms
			40	100	ms	I _p = AC60mArms
			5	15	ms	I _p = AC150mArms
			3	15	ms	I _p > AC 5Arms
Sensitivity (pin 3)	G		40		V/A	-40 to 85°C
Offset voltage (pin 3)	Vo		2.25		V	-40 to 85°C
Measurement range(pin 3)	I _p	-50		50	mA	
Frequency range (pin 3)	fBW	DC		150	Hz	-3dB *Note1

* Parameter without Max or Min values are designed values, are not guaranteed values.

Note1: Please refer to Appendix 1 for frequency characteristics of Pin3.

6-2. ESD

Judgment: Idn (DC) within Specification of 6-1 items after ESD test

Parameter	Judge
Electrostatic Discharge Voltage Human-body model (HBM) R=1.5kΩ, C=100pF, U=+/-2kV	Passed
Electrostatic Discharge Voltage Charged-device model (CDM) U=+/-800V	Passed

6-3. EMC

Judgment: DC Alarm and AC Alarm do not malfunction during noise stimulation

Parameter	Conditions	Judge
IEC 61000-4-3 Radiated, radio-frequency, electromagnetic field immunity	30V/m, 80MHz – 1GHz 80%AM 1kHz	Passed
ISO 11452-2 (ALSE) electrical disturbances from narrowband radiated electromagnetic energy	50V/m 200MHz – 800MHz 80%AM 1kHz, 800MHz – 2GHz PM	Passed
ISO 11452-4 (BCI) Electrical disturbances from narrowband radiated electromagnetic energy	100mA 20MHz – 200MHz 80% AM 1kHz	Passed

6-4. Dielectric strength

Parameter	Conditions	Value
$U_{W, \text{prim-sec}}$	Impulse(1.2us/50us), PIN1-6 vs insulated primary wire, 5 pulse -> polarity +, 5 pulse -> polarity -	5.5kVrms
U_d	Test voltage, 60s PIN1-6 vs insulated primary wire	1.5kVrms
$U_{PDx1.5}$	Partial discharge voltage, PIN1-6 vs insulated primary wire *acc. to table 24	1.2kVrms
$U_{PDx1.875}$	Partial discharge voltage, PIN1-6 vs insulated primary wire *acc. to table 24	1.5kVrms

* IEC 61800-5-1:2007

Note2:

The case is Insulation material group III.

When designing the primary wire, be careful of clearance and creepage distance from the input/output terminal.

Note3: Please See Appendix2 for recommended wire configuration

6-5. Frequency characteristics

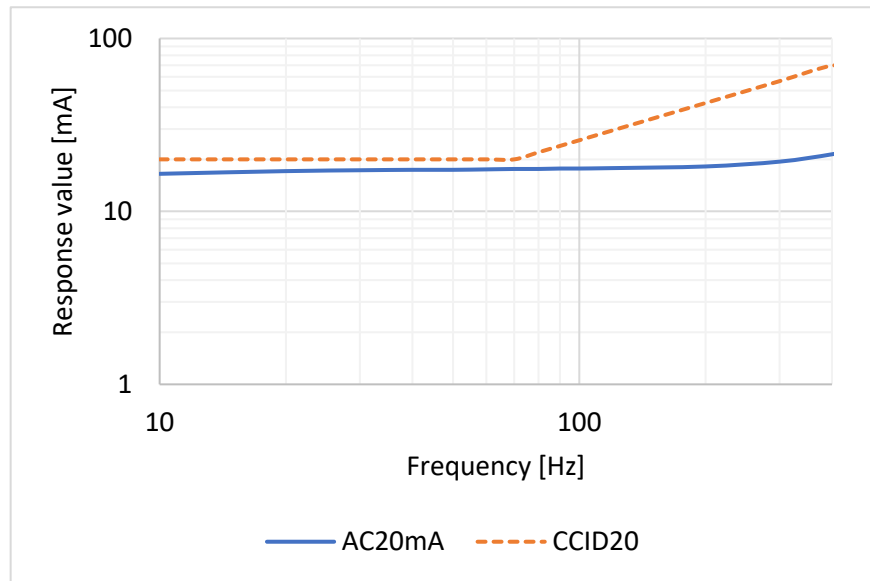

*This characteristic is indicated only for reference, and are not guaranteed.

6-6. Digital Output state

DC Alarm	AC Alarm	State
GND	GND	Normal condition
High impedance	GND	$I_{dn} > 6\text{mA(DC)}$
GND	High impedance	$I_{dn} > 20\text{mA(AC)}$
High impedance	High impedance	$I_{dn} > 6\text{mA(DC)}$ & $I_{dn} > 20\text{mA(AC)}$

Other instructions:

- Temperature of primary wire should not exceed 105°C.
- The rise time of Vdd is 50us to 100 ms.
- UL2231 Recognized component expected

6-7 Self-test operation

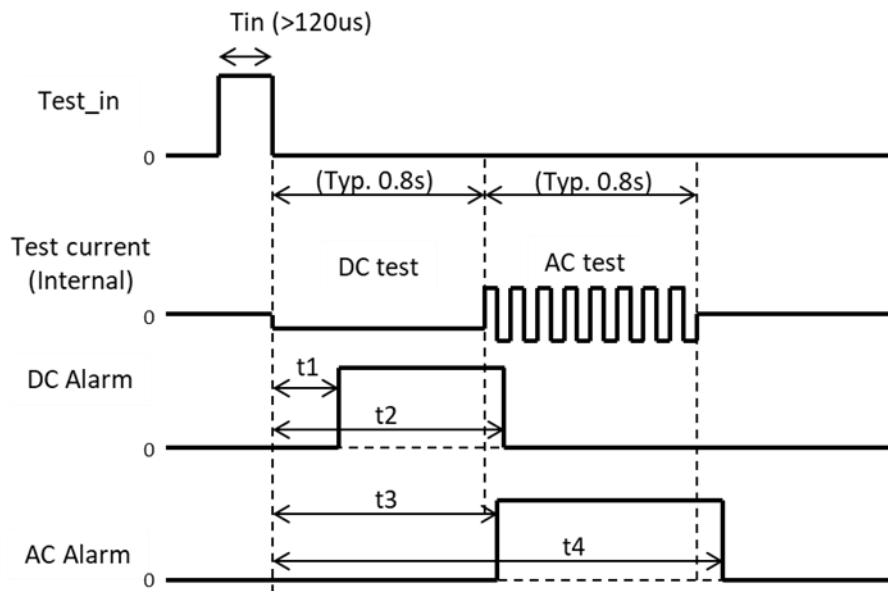
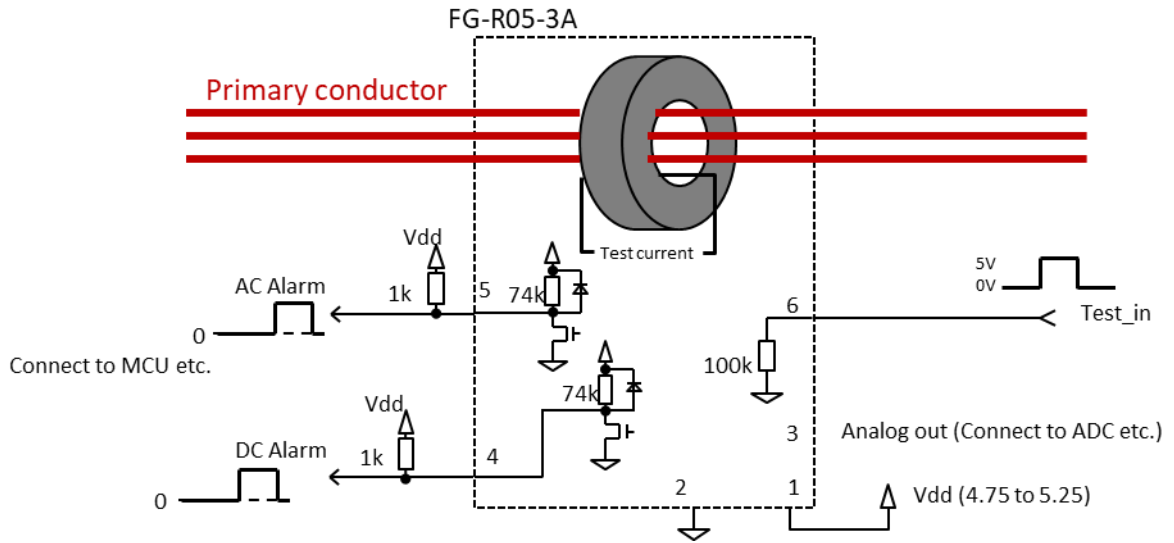

Parameter	Min	Typ	Max
t1	0.06	0.15	0.3
t2	0.7	1.0	1.3
t3	0.7	1.0	1.2
t4	1.4	1.8	2.1

[sec]

6-8 Recovery level

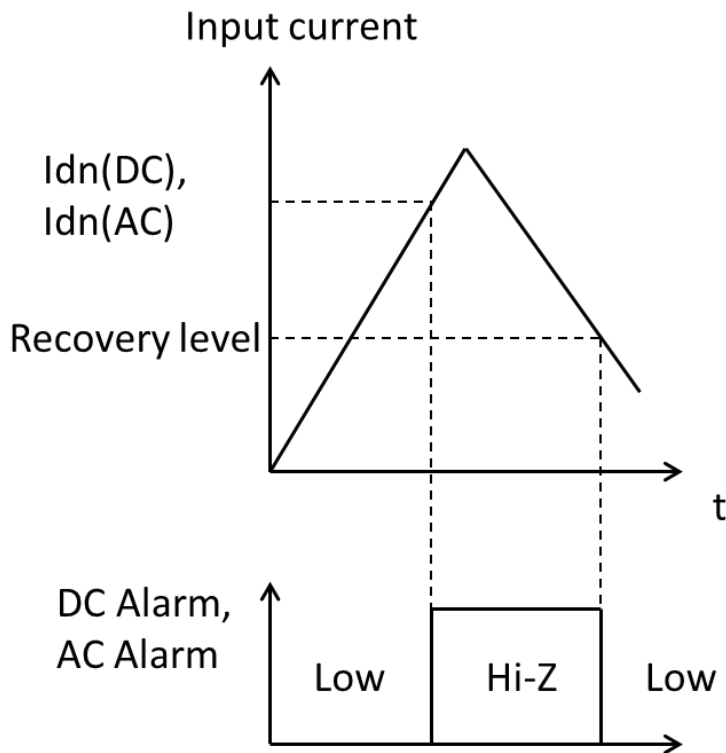

When the residual current exceeds the threshold level ($I_{dn}(DC)$ or $I_{dn}(AC)$), PIN 4(DC Alarm) or PIN 5(AC Alarm) will change from low level(GND) to high impedance. Each output goes back from high impedance to low level when residual current falls below recovery level.

7. PCB footprint (Top view)

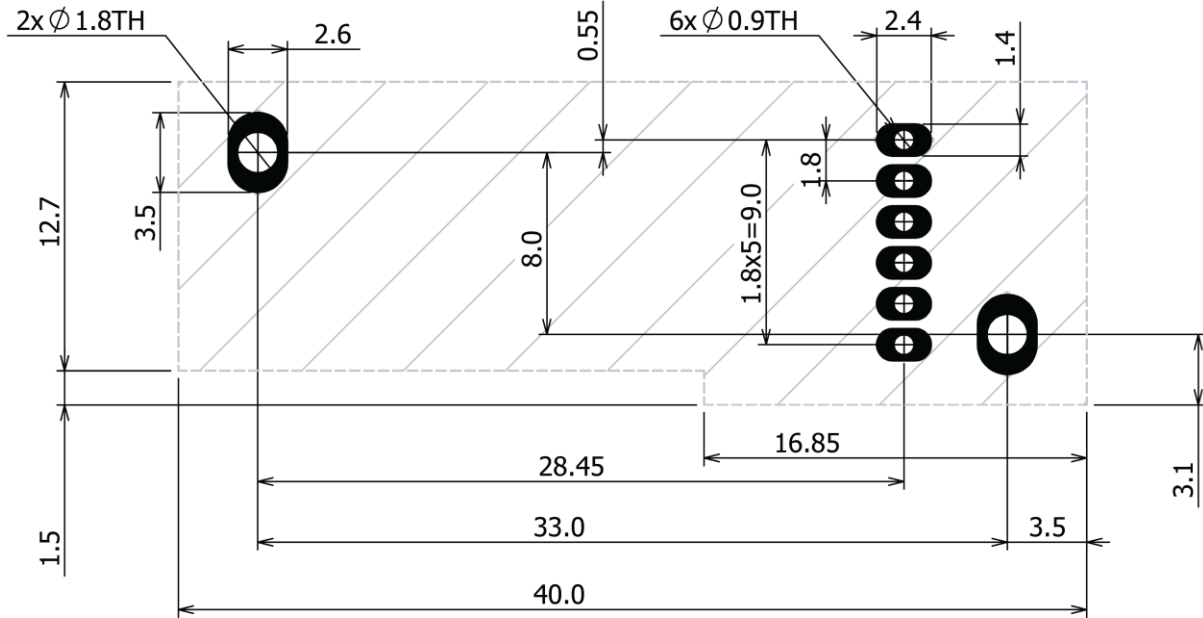

8. Dimensions

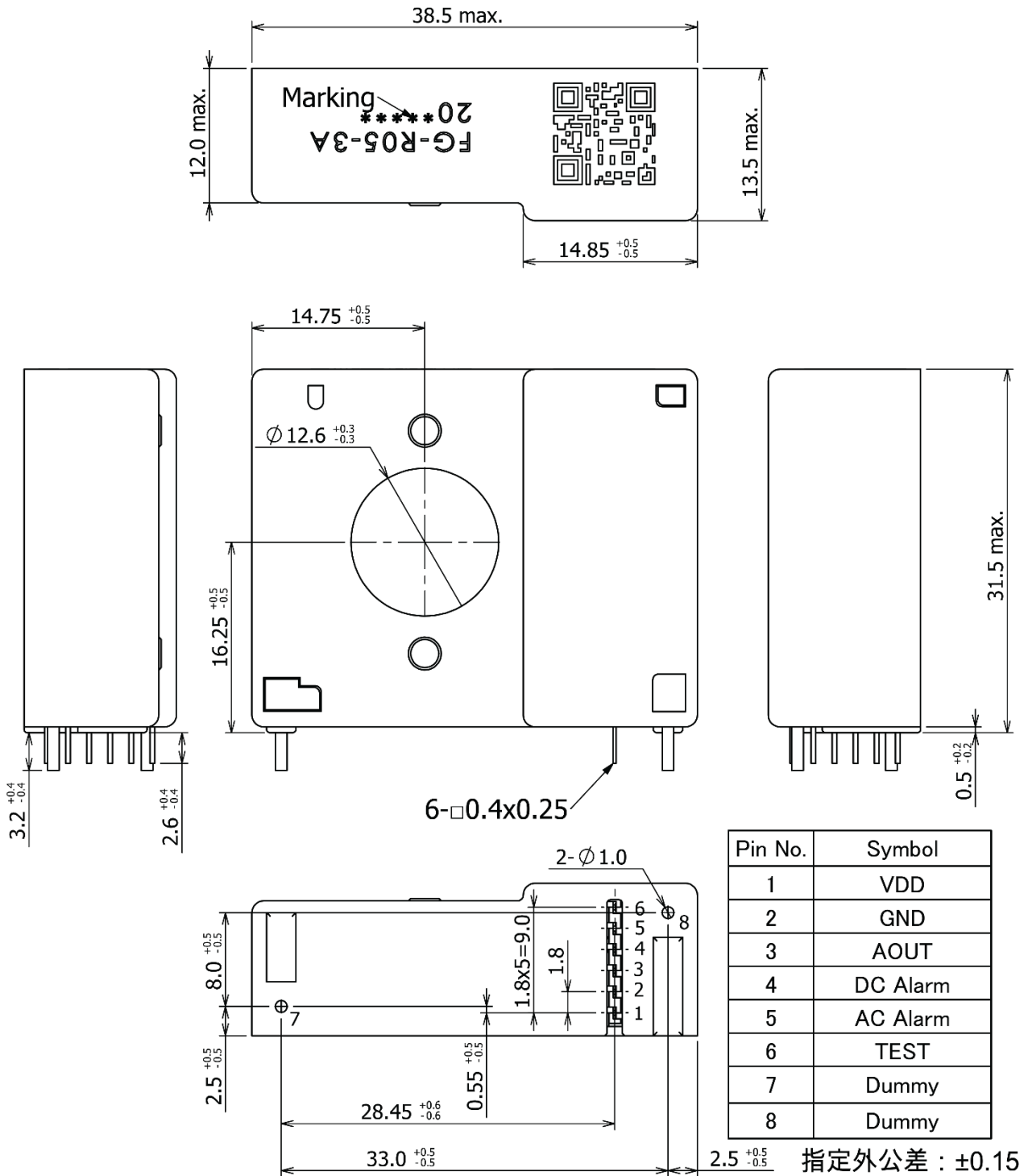

9. Packing

The product is packed in a special tray and carton box as shown below.
The tray would be an antistatic type.

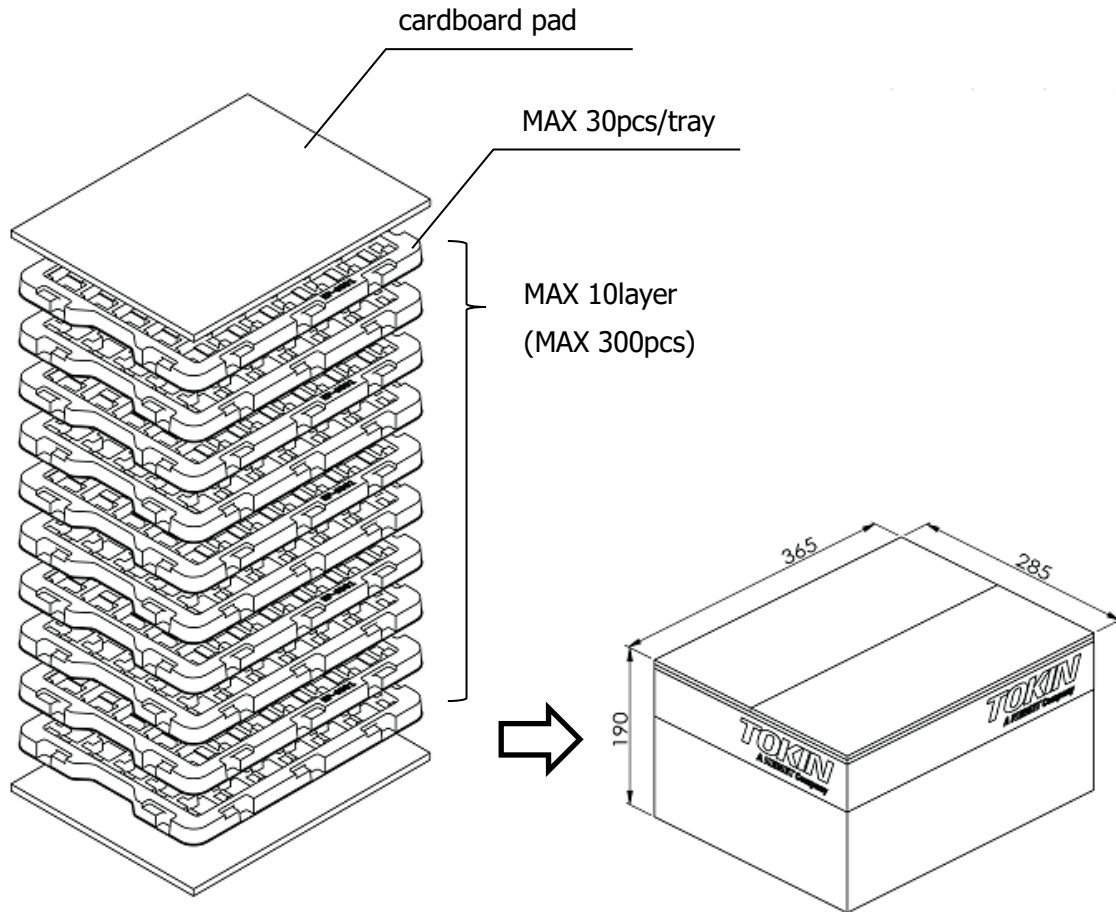

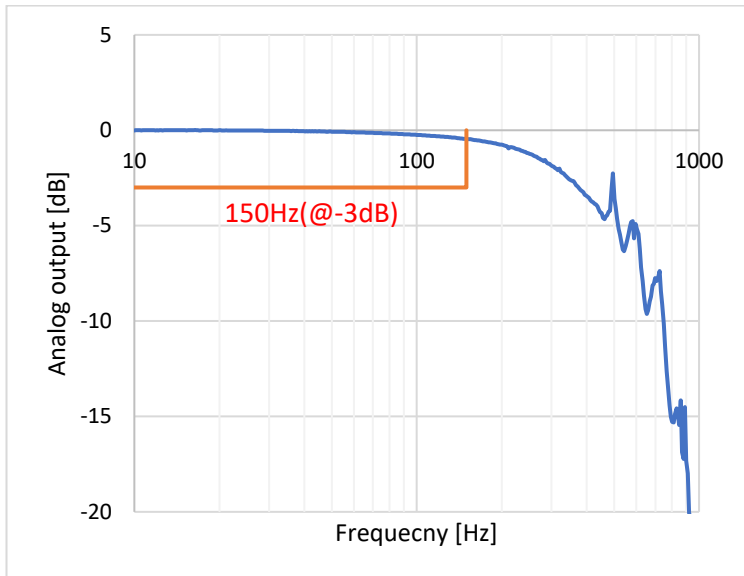

*This characteristic is indicated only for reference, and are not guaranteed.

Appendix 2

Recommended wire configuration

In case of insulated wire

Three phase system <480V

AWG10

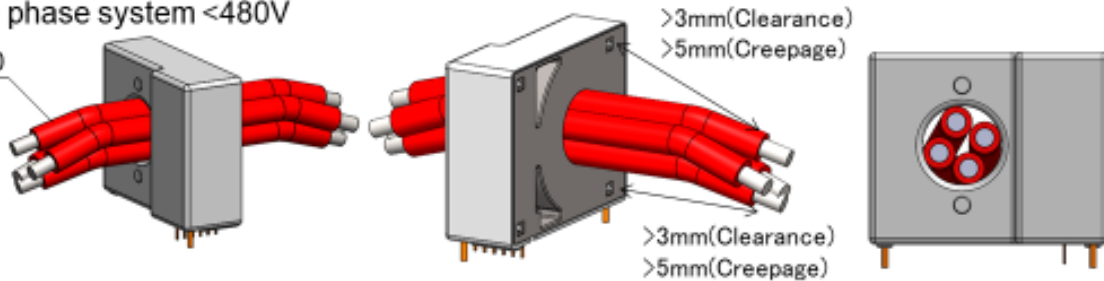

In case of bare wire

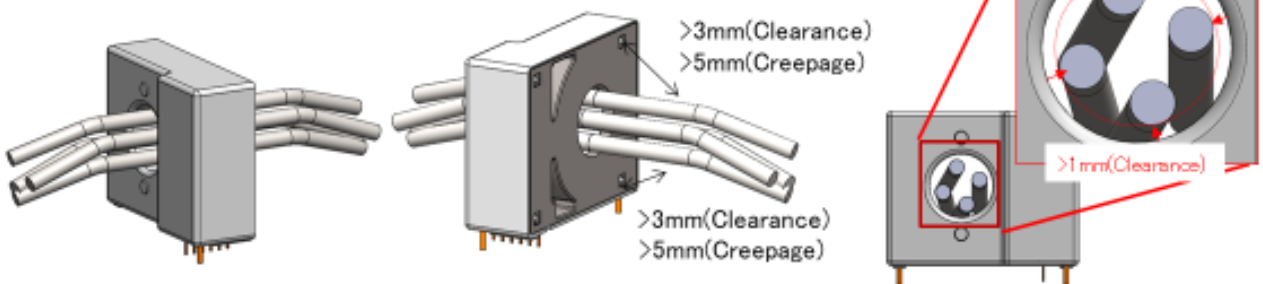

*Reinforced insulation, Insulation material group III, Pollution degree 2, altitude<5000m and overvoltage category II
 *Please take enough creepage distance between each pin