

Specification

- Part No. : **MA111.W.C.LB.001**
- Product Name : White MA.111 **Ultima** Series – 2in1 Super Low Profile
Combination GPS/GLONASS/GALILEO and Penta Band
Cellular Antenna Screw-mount (Permanent mount)
- Feature : Height 19.6mm (0.77”) Diameter 55mm (2.17”)
Heavy duty permanent mount
UV and vandal resistant ABS housing and thread
IP67 compliance
GPS/GLONASS/GALILEO - 3M RG-174 SMA(M)
Cellular – 3M CFD-200 SMA(M)

RoHS Compliant



1. Introduction

The MA111 Ultima Series 2in1 GPS/GLONASS/GALILEO & Cellular Combination Antenna is an extremely low profile combination high performance GPS/GLONASS/GALILEO and penta-band cellular antenna solution for professional telematics applications. At only 22 mm height it is the lowest profile antenna in the market, with a diameter of 55 mm. It is designed to be mounted and couple to the metal structures it attaches to radiate. Durable UV ABS housing, thread and nut is resistant to vandalism and direct attack.

The IP67 waterproof robust plastic body makes it extremely light, economical for shipping and minimum weight impact on vehicles. This also makes it ideal for use in humid environments such as water pits or marine applications as there are no external metal parts to corrode. The closed cell foam with double-sided adhesive provides a permanent waterproof seal and can adjust to different curvatures, stopping water from leaking under the antenna into the mounting hole. Cable and connectors are fully customizable, for more information ask your local Taoglas Sales office.

For applications that require mounting on non-metal structures we recommend the Hercules MA.105.

1.1. System Configuration

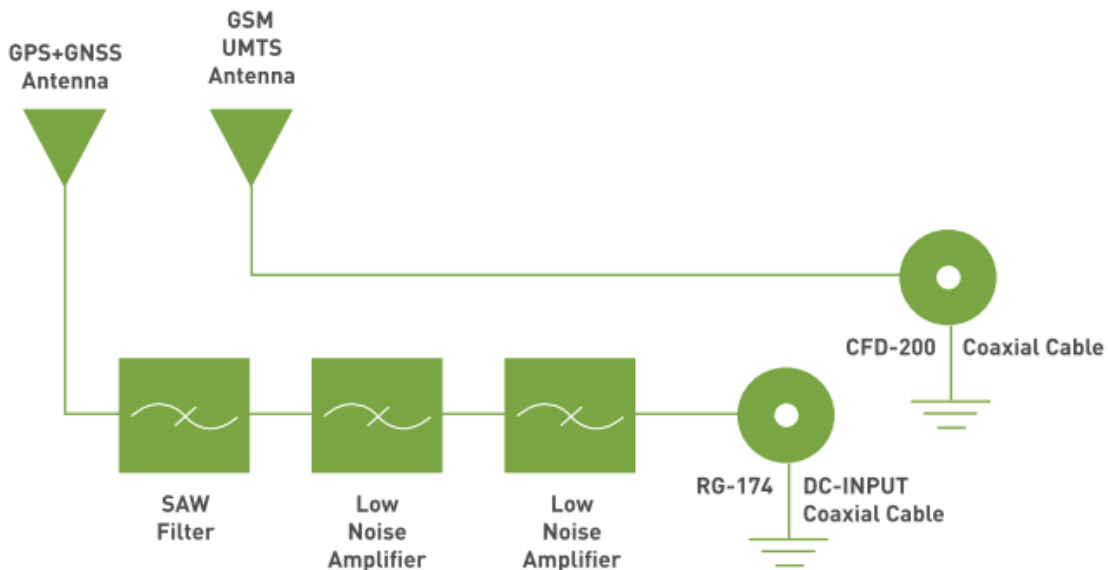

2. Specification

CELLULAR					
Frequency (MHz)	824 ~ 896	880 ~ 960	1710 ~ 1880	1850 ~ 1990	1710 ~ 2170
Peak Gain (dBi)	>1.5	> 3.0	> 2.0	> 4.0	>2.5
Average Gain (dBi)	-0.39	-0.39	-0.39	-0.30	-0.45
Efficiency (%)	>40	>40	>40	>50	>35
SWR	< 2.5	< 2.0	< 3.5	< 3.0	< 3.0
Polarization	Linear				
Radiation Pattern	Omni				
Input Power	50Ω				

ELECTRICAL GPS/GLONASS/GALILEO	
Frequency (MHz)	1574~1606MHz
Impedance (Ohm)	50Ω
GPS/GALILEO Patch Gain@ Zenith GLONASS Patch Gain@ Zenith	-1.4dB Passive Gain @ Zenith -1.3dBi Gain @ Zenith
VSWR	2.0 max
Axial ratio	3.0dB max
Polarization	RHCP
Out Band Rejection	fo = 1575.42MHz fo ± 30 MHz 5dB Min. fo ± 50 MHz 20dB Min. fo ± 100 MHz 25dB Min.
Input Voltage(V)	Typ. 2.5~5.5V
Total Gain @ Zenith	27dB typical at 3.0V
Current consumption(mA)	10mA typical at 3.0V
Noise figure	1.3dB typical
MECHANICAL	
Dimensions	Φ55±2mm, Height 30±2 mm
Cable type	Cellular: CFD-200 GPS/GLONASS/GALILEO: RG-174
Cable length	3000±30mm
Casing	ABS
Connector	SMA Male
Recommended Mounting Torque	3.92Nm
Maximum Mounting Torque	4.9Nm
Weight	202.5g
ENVIRONMENTAL	
Temperature Range	-40°C to 85°C
Waterproof	IP-67 & IP69K
Thermal Shock	100 cycles -40°C to +80°C
Shock (drop test)	1m drop on concrete 6 axes
Humidity	Non-condensing 65°C 95% RH

3. Antenna Characteristics Cellular

3.1. Cellular antenna Return loss (with 300x300mmGround plane)

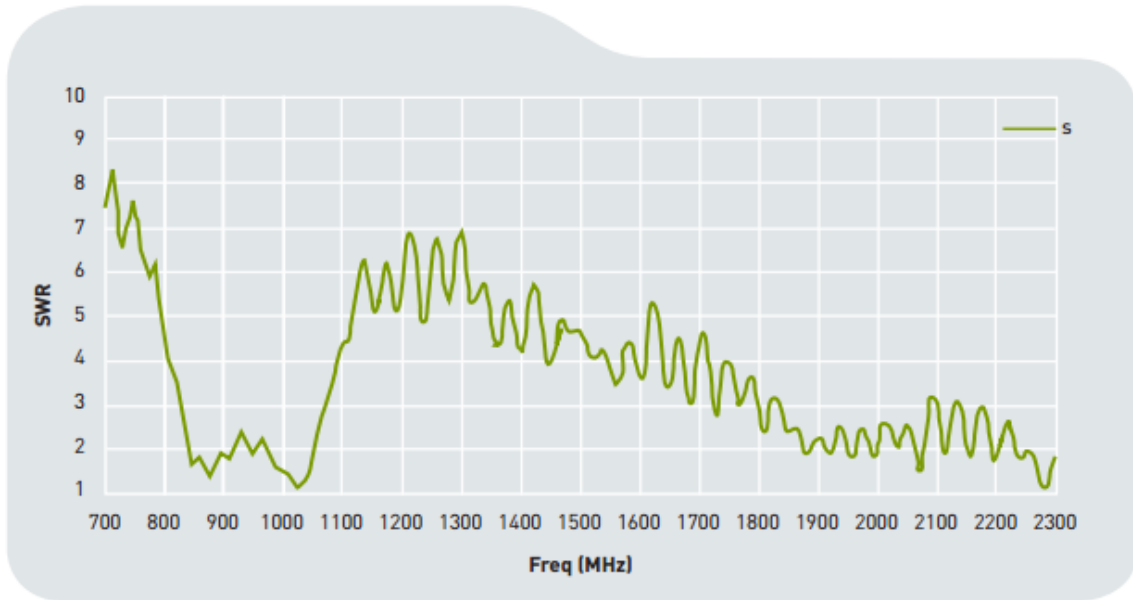

3.2. Antenna Efficiency (with 300x300mmGround plane)

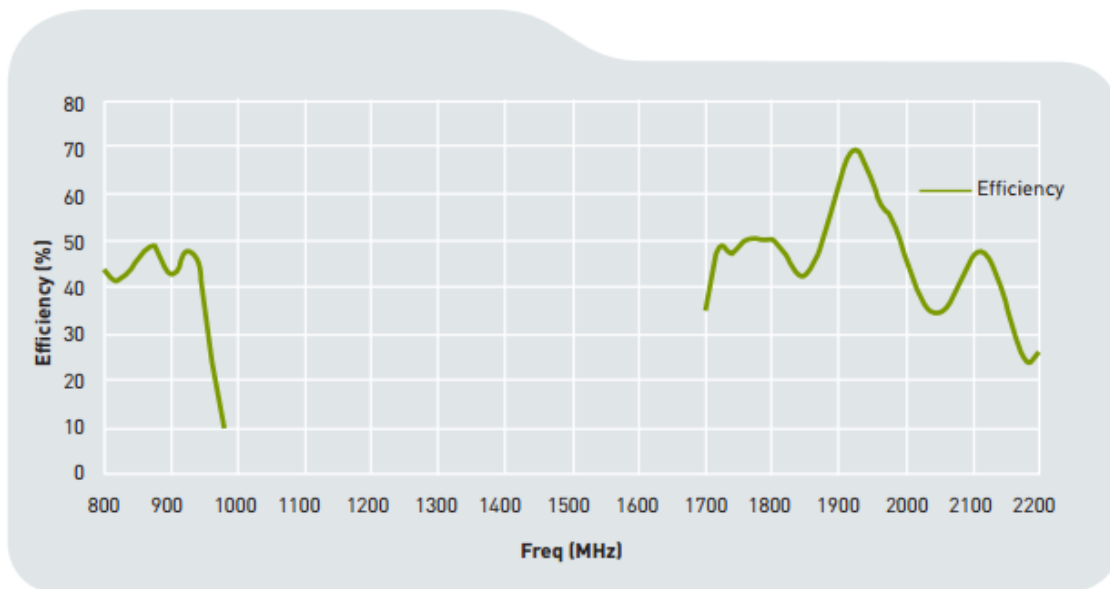

3.3. Peak Gain (with 300x300mm Ground plane)

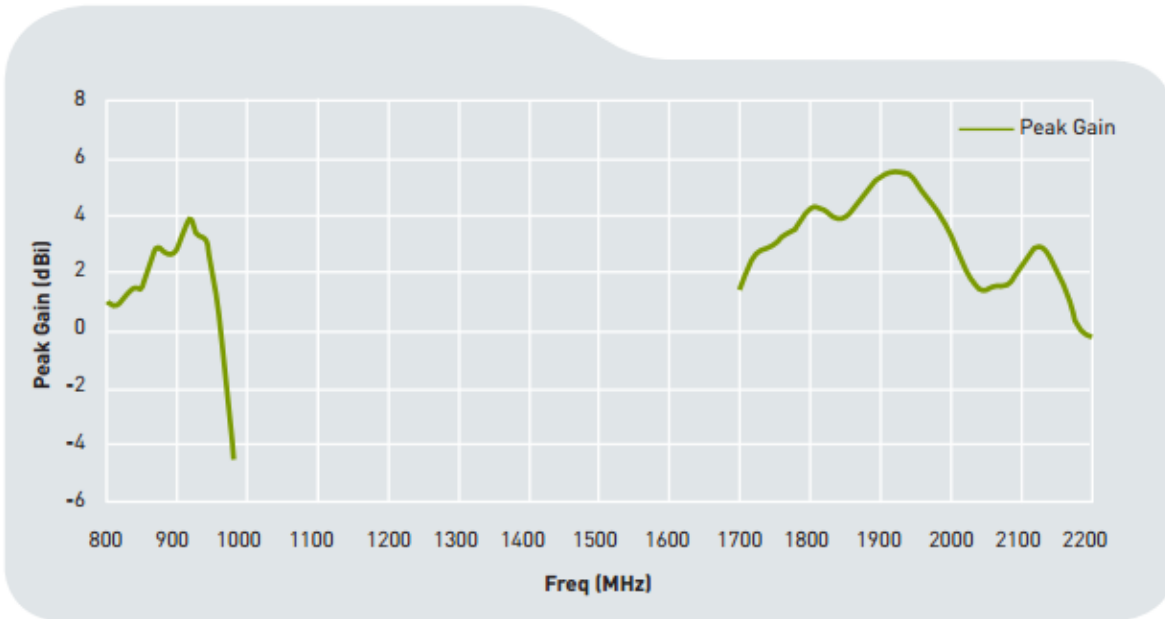

4. Antenna Characteristics

GPS/GLONASS/GALILEO

4.1. Return Loss

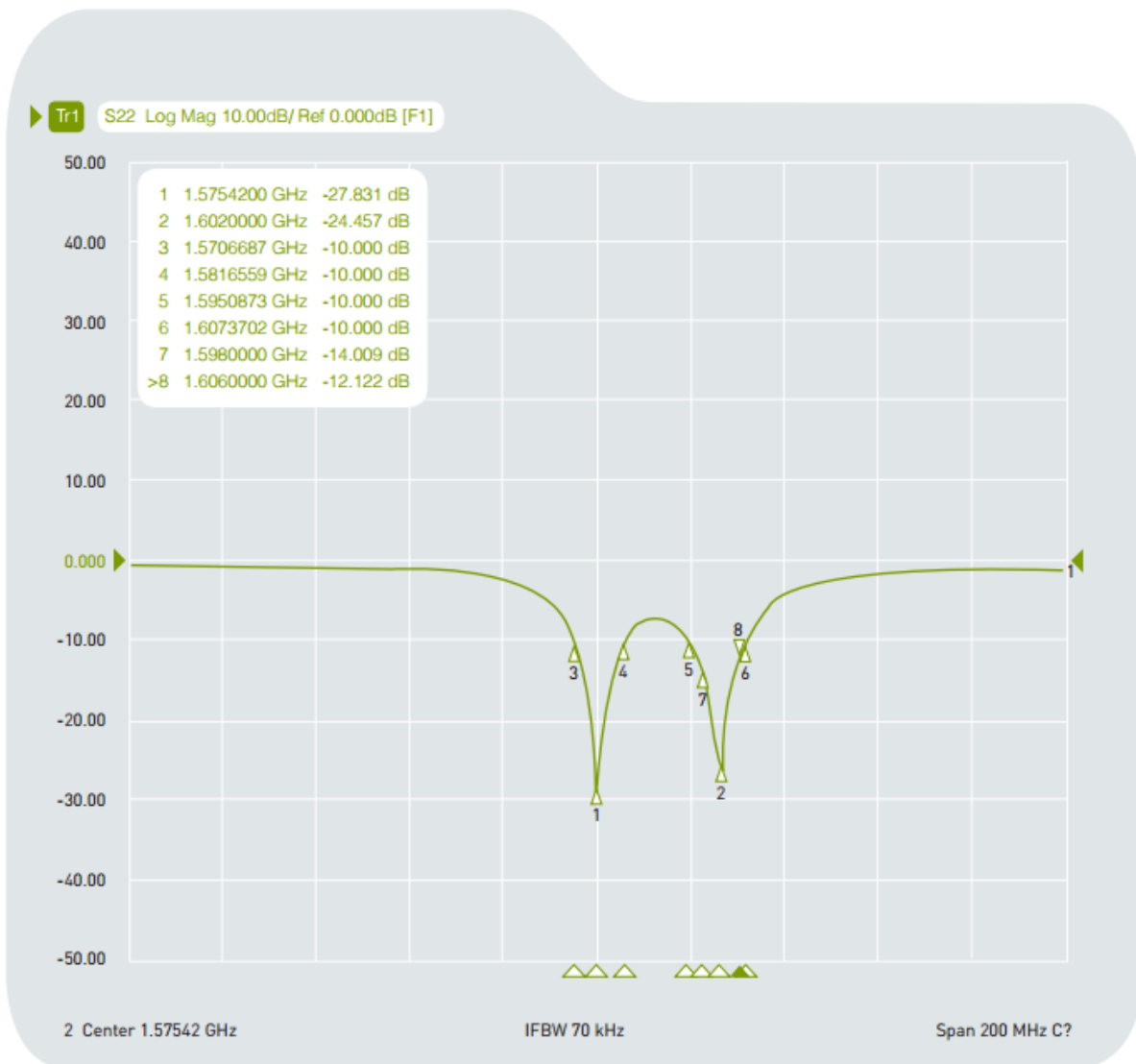

4.2. Smith Chart - Impedance

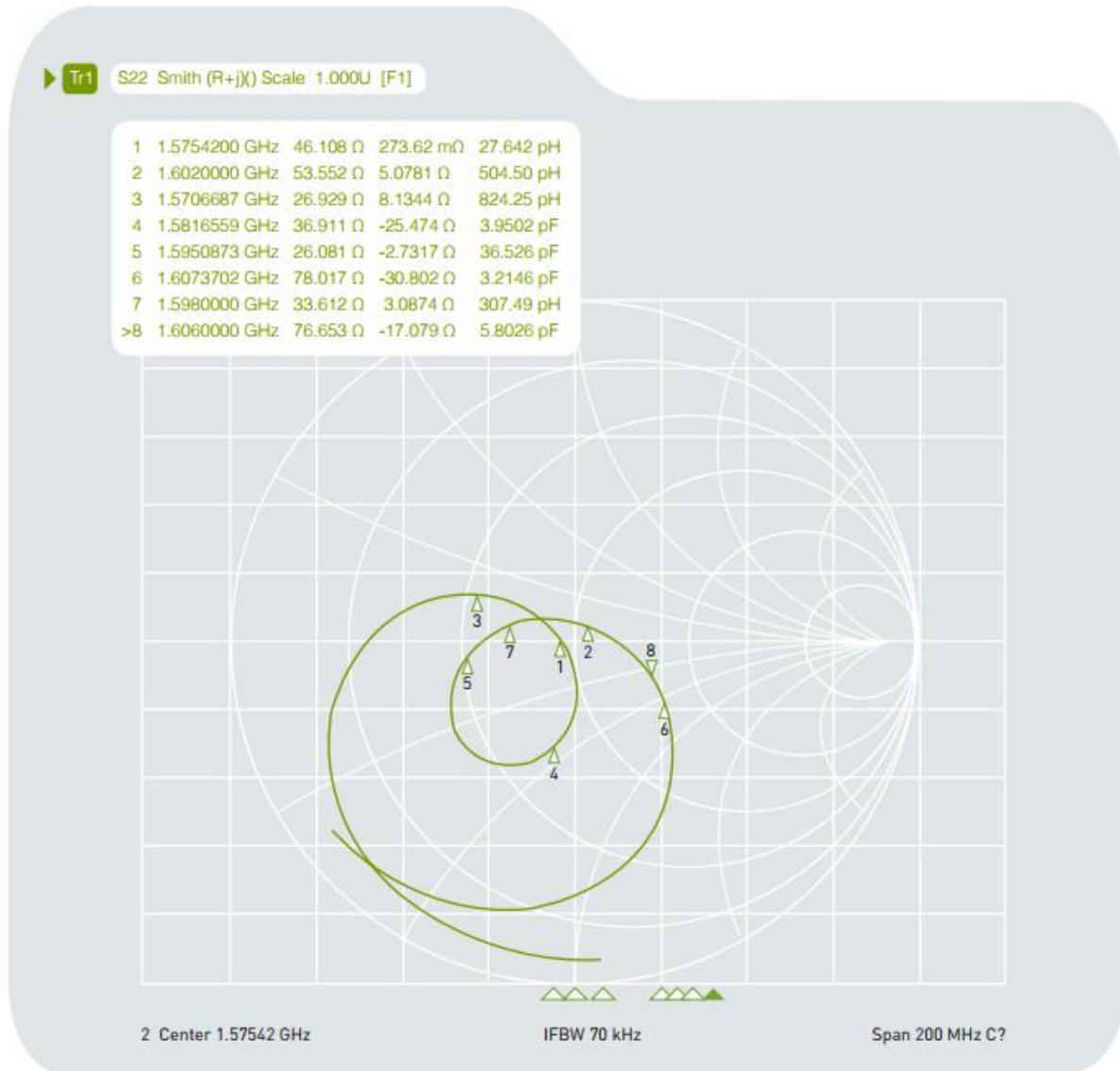

4.3. Axial ratio (AR)

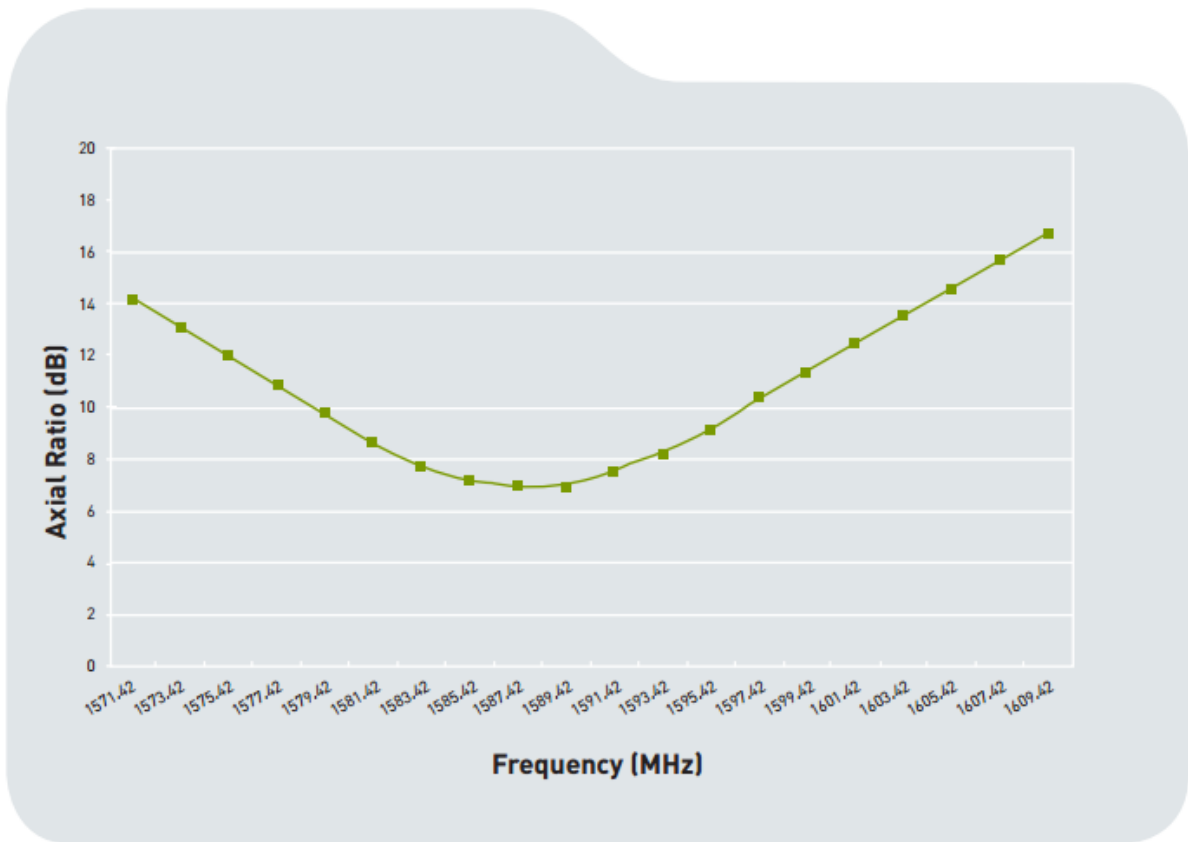

5. Antenna Radiation Pattern-Cellular

5.1. Antenna Setup (cellular)

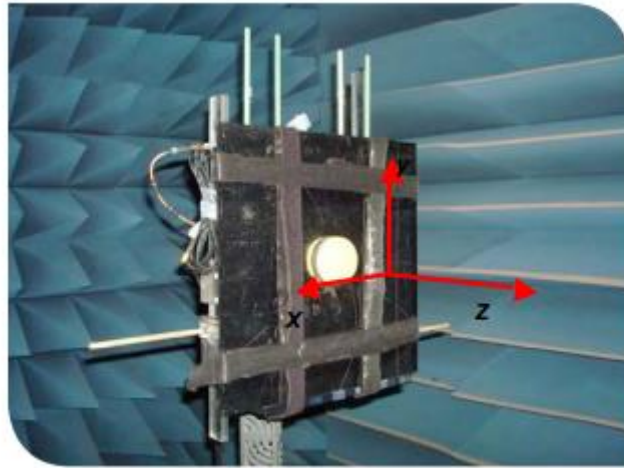

5.2. Radiation Pattern

5.2.1. X-Y plane (dBi)

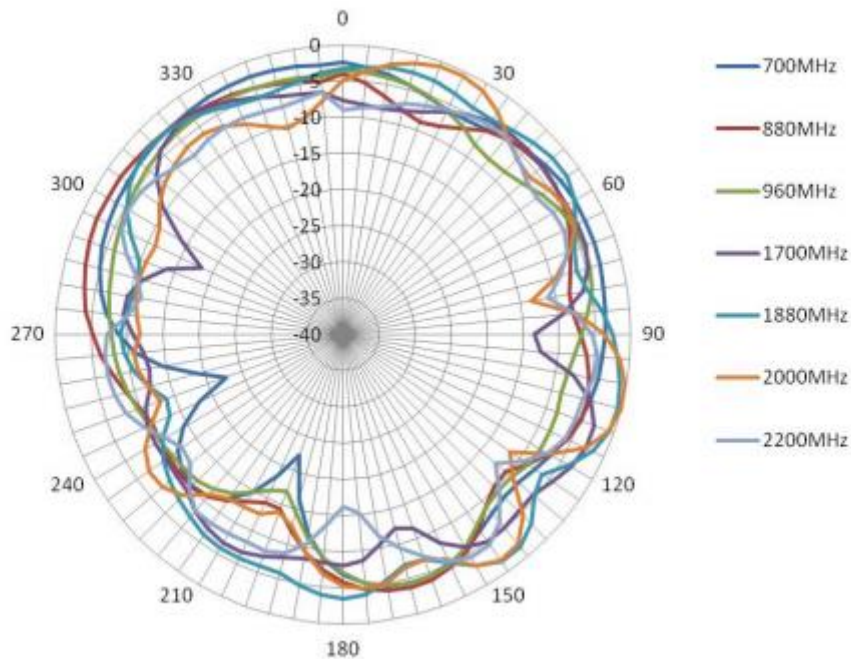

5.2.2. X-Z plane (dBi)

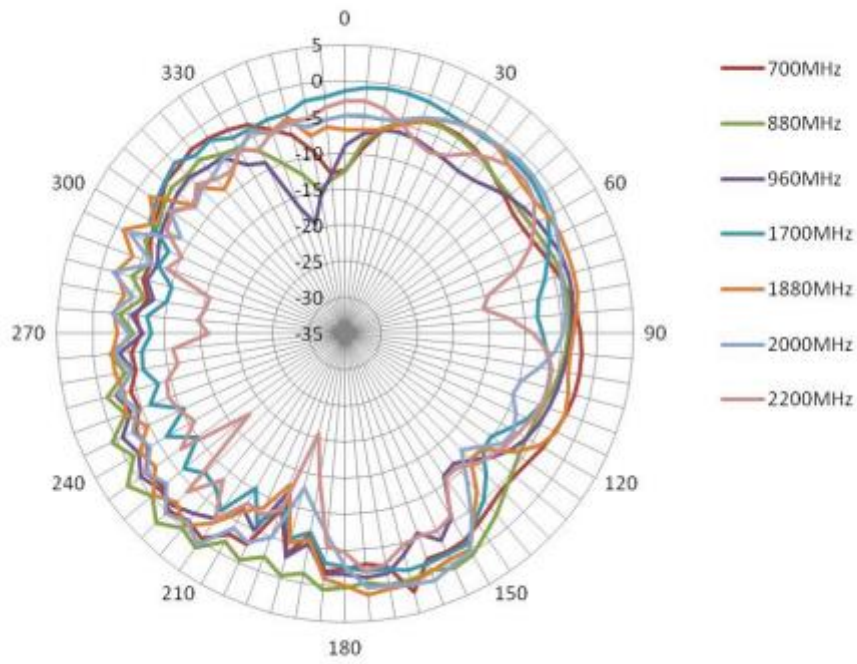

5.2.3. Y-Z plane (dBi)

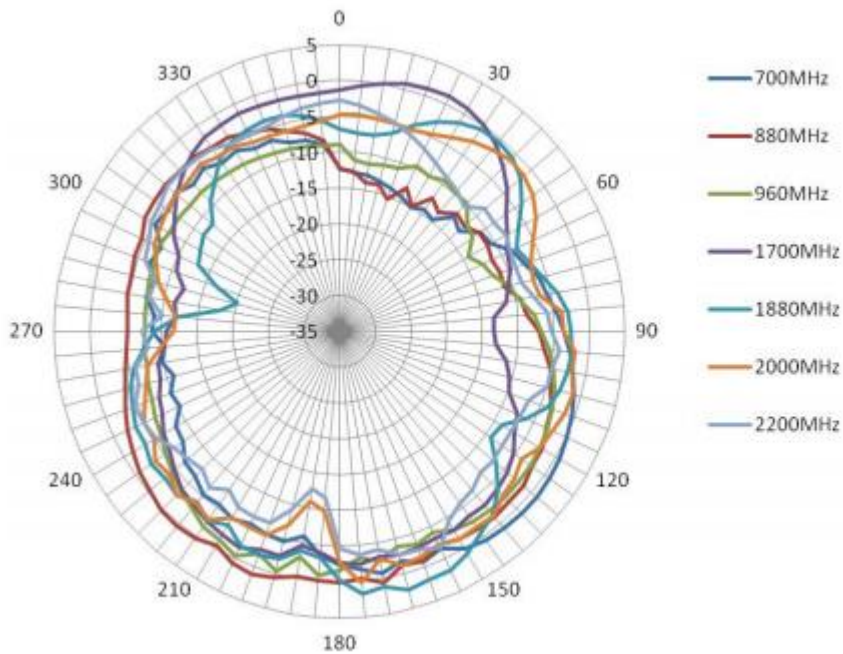

6. Antenna Radiation Pattern – GPS/GLONASS/GALILEO

H-Plane



E-Plane



6.1.1. 1575.42MHz

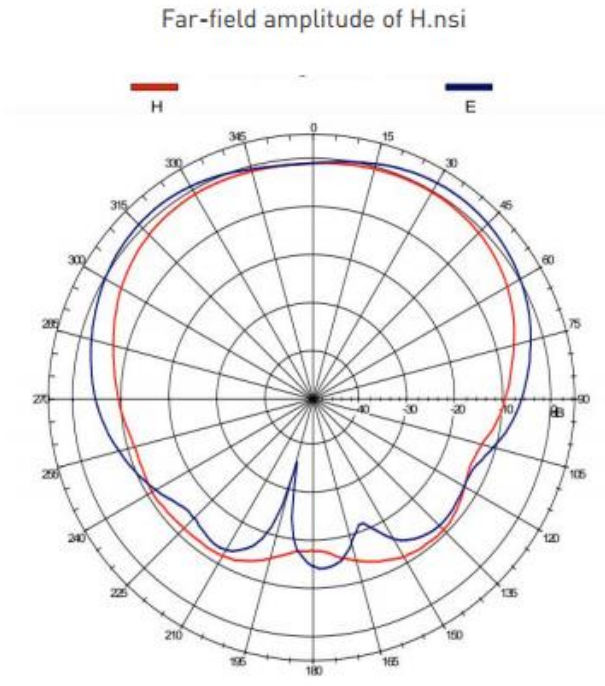

6.1.2. 1598MHz

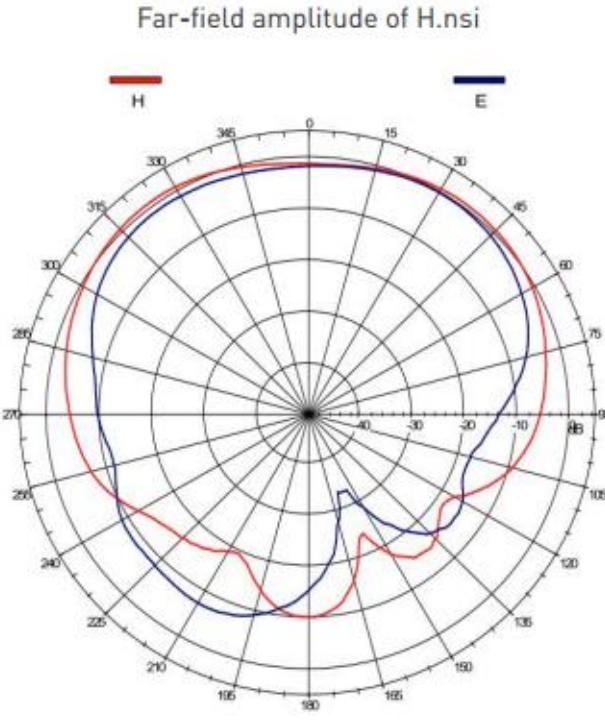

6.1.3. 1602MHz

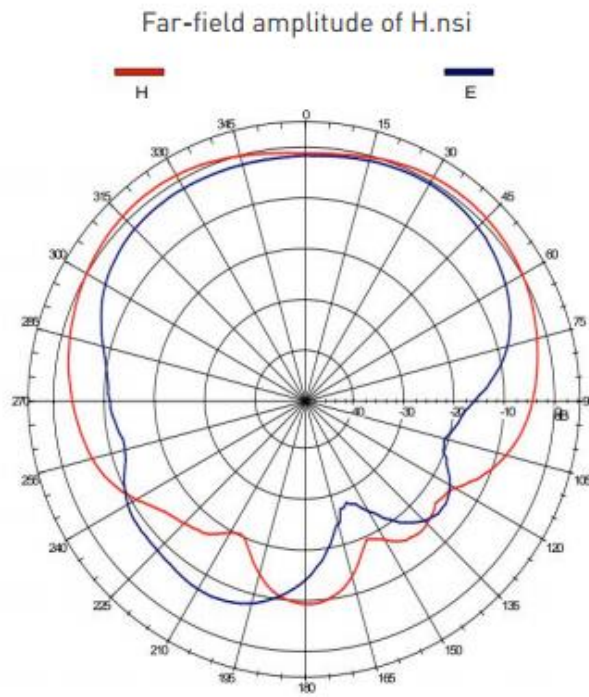

6.1.4. 1606MHz

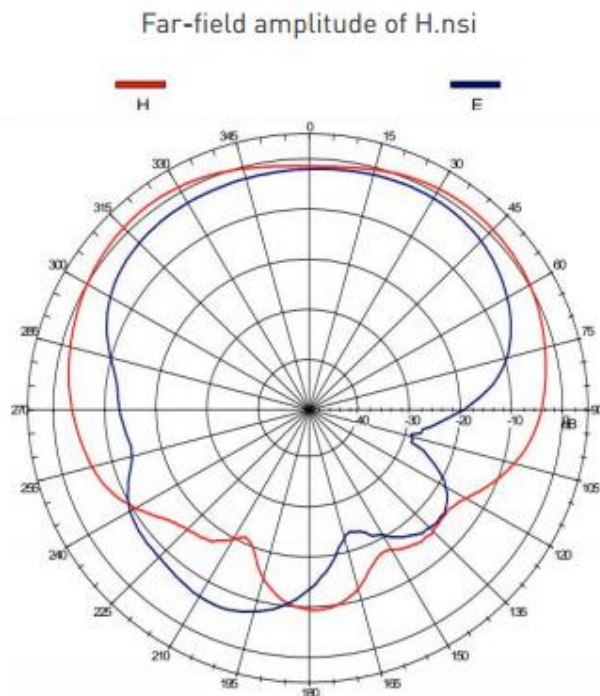

7. Drawing

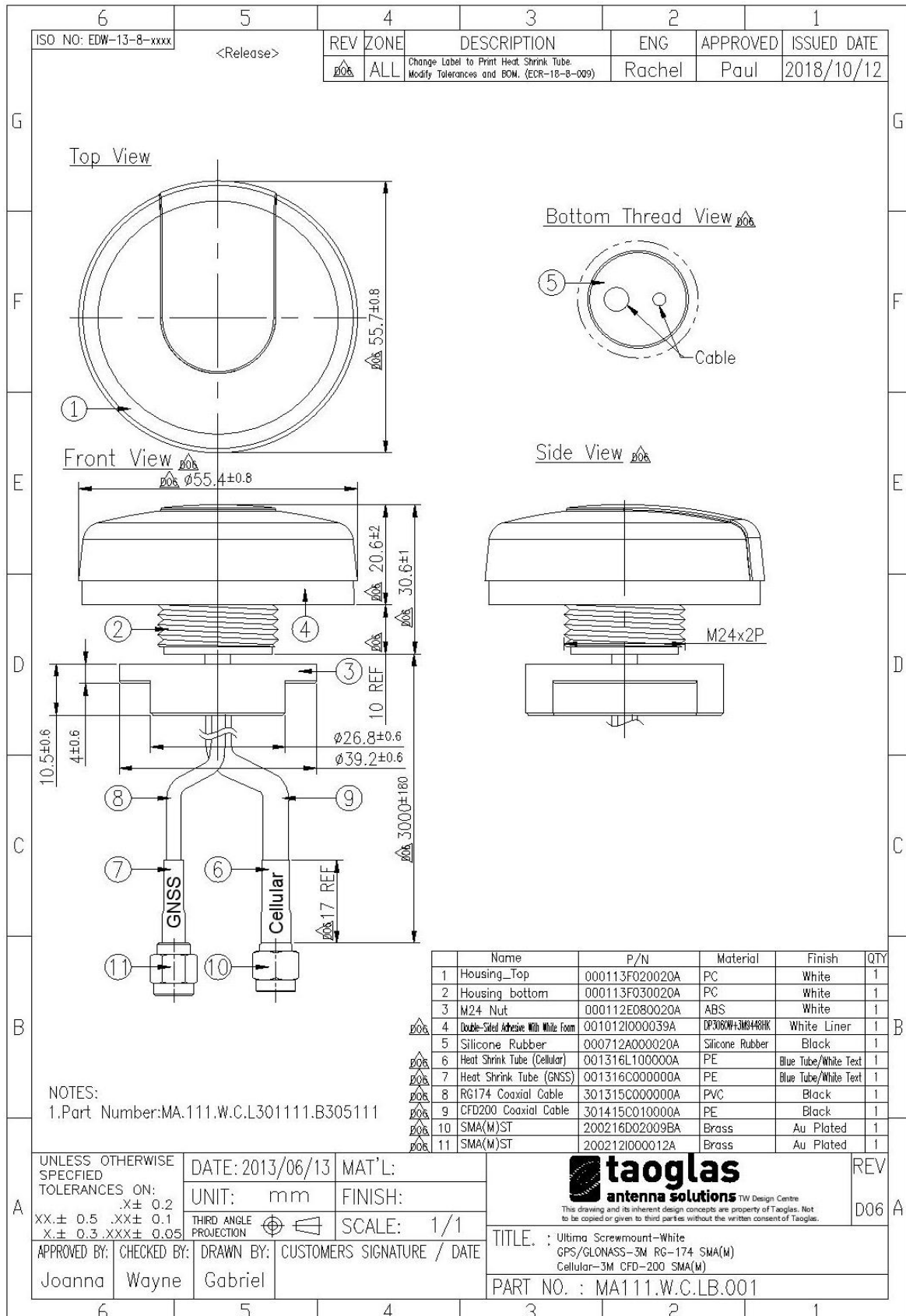

8. Installation

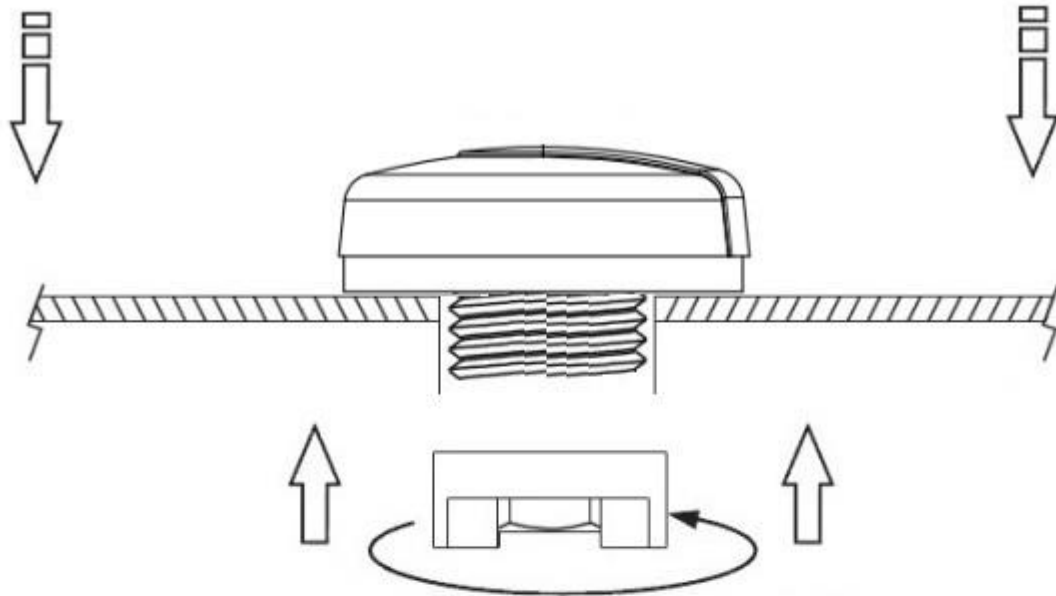

Recommended torque for Mounting is 3.92N·m
 Maximum torque for Mounting is 4.9N·m

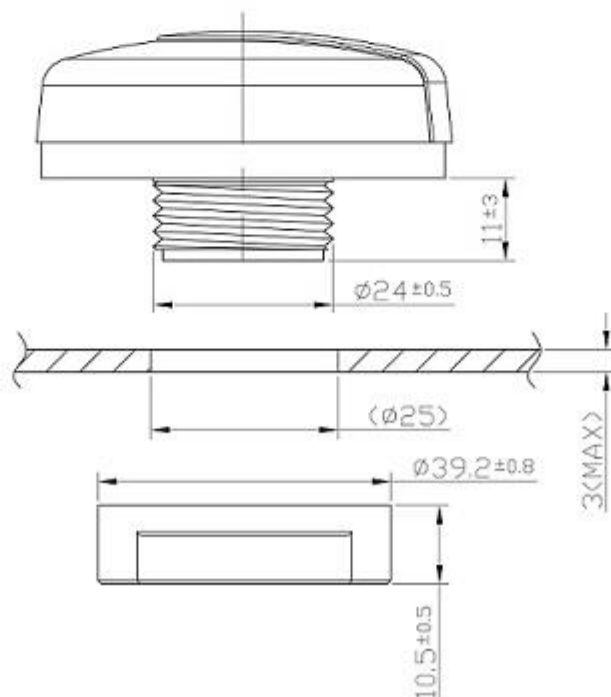

9. Packaging

1 pcs antenna per small PE bag
40 small PE bags per box

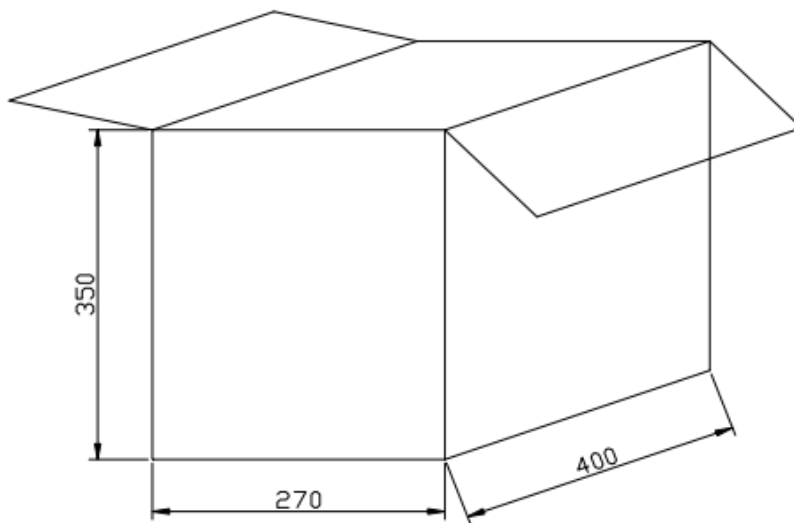
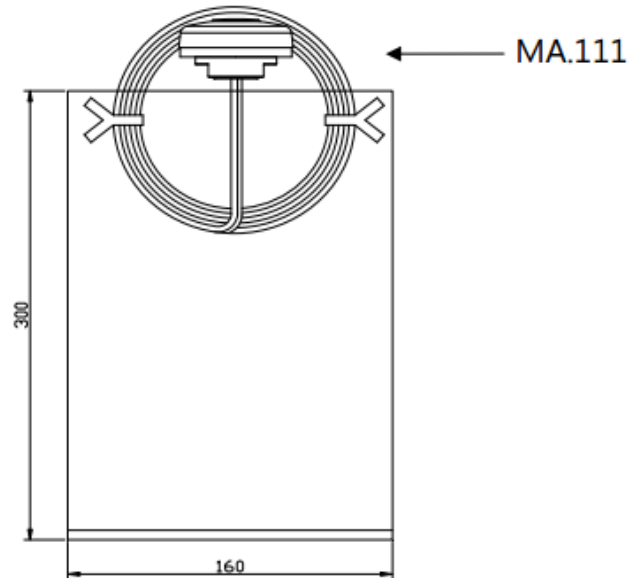

Taoglas makes no warranties based on the accuracy or completeness of the contents of this document and reserves the right to make changes to specifications and product descriptions at any time without notice. Taoglas reserves all rights to this document and the information contained herein.

Reproduction, use or disclosure to third parties without express permission is strictly prohibited.

Copyright © Taoglas Ltd.